

DEPARTMENT OF TRANSPORTATION**National Highway Traffic Safety Administration**

[Docket No. NHTSA–2024–0078]

New Car Assessment Program Final Decision Notice—Crashworthiness Pedestrian Protection

AGENCY: National Highway Traffic Safety Administration (NHTSA or the Agency), Department of Transportation (DOT).

ACTION: Final decision notice.

SUMMARY: This final decision notice adds a crashworthiness pedestrian protection program to the New Car Assessment Program (NCAP) to evaluate new model year vehicles' abilities to mitigate pedestrian injuries. Based on its previous research, NHTSA concurs with and adopts most of the European New Car Assessment Programme's (Euro NCAP) pedestrian crashworthiness assessment methods, including the injury limits for test devices and the score calculation method used for impact points. NHTSA will identify new model year vehicles meeting a certain minimum safety threshold on the Agency's website and other published literature. This notice responds in part to the provisions in Section 24213 of the Infrastructure Investment and Jobs Act (IIJA), which requires NHTSA to incorporate measures in NCAP for evaluating the protection that new vehicles provide vulnerable road users like pedestrians.

DATES: These changes to the New Car Assessment Program are effective for the 2026 model year.

FOR FURTHER INFORMATION CONTACT: For technical issues, you may contact Ms. Christina Smith, New Car Assessment Program, Office of Crashworthiness Standards (Telephone: (202) 366–1810). For legal issues, you may contact Ms. Natasha D. Reed or Mr. Matthew Filpi, Office of Chief Counsel (Telephone: (202) 366–2992). You may send mail to either of these officials at the National Highway Traffic Safety Administration, 1200 New Jersey Avenue SE, West Building, Washington, DC 20590–0001.

SUPPLEMENTARY INFORMATION:**Table of Contents**

- I. Executive Summary
 - A. Legal and Policy Considerations
 - 1. 2021 Bipartisan Infrastructure Law (BIL)
 - 2. 2022 U.S. Department of Transportation (DOT) National Roadway Safety Strategy (NRSS)
- II. Summary of Updates to NCAP
- III. Background
 - A. Adopted Testing Devices

- B. Adopted Test Procedures
- C. Adopted Component Scoring Method
- D. Adopted Procedure for Manufacturer-Submitted Data
- E. Verification Testing Process
- F. Adopted Vehicle Scoring Apportionment
- IV. Summary of General Comments on Proposed NCAP Updates
- V. RFC Comments and Agency Decision
 - A. Test Zone and Markup
 - 1. RFC Summary
 - 2. Comments Received
 - 3. Discussion and Agency Decision
 - B. Test Devices
 - 1. RFC Summary
 - 2. Comments Received
 - 3. Discussion and Agency Decision
 - C. Test Procedure
 - 1. RFC Summary
 - 2. Comments Received
 - 3. Discussion and Agency Decision
 - D. Data Acquisition and Reporting
 - 1. RFC Summary
 - 2. Comments Received
 - 3. Discussion and Agency Decision
 - E. Other Comments
 - 1. Comments Received
 - 2. Discussion and Agency Decision
- VI. Procedure in Detail
 - A. Differences From Euro NCAP Tests and Assessment Protocols
 - 1. Use of the FlexPLI
 - 2. No FlexPLI Bumper Testing When LBRL Is Greater Than 500 mm
 - 3. FlexPLI Qualification Procedure and Testing
 - 4. Bumper Corner Definition
 - 5. Active Hood Detection
 - 6. WAD Limit
 - 7. Self-Reporting System
 - 8. NCAP Scoring Apportionment
 - 9. Credit Publication Process
 - B. Injury Limits and Scoring Process
 - 1. Headform Tests
 - 2. Upper Legform Tests
 - 3. Lower Legform Tests
 - C. NCAP Proposal for Awarding Credit
 - D. NCAP Verification Testing
- VII. Conclusion
- VIII. Economic Analysis
- IX. Appendices
 - Appendix A: Questions From RFC
 - Appendix B: Supplementary Tables
 - Appendix C: Vehicle Scoring and Verification Testing Example—Passenger Car

I. Executive Summary

The National Highway Traffic Safety Administration's (NHTSA) New Car Assessment Program (NCAP) provides comparative information on the safety performance of new vehicles and availability of new vehicle safety features to assist consumers with vehicle purchasing decisions and to encourage safety improvements. NCAP, like many other NHTSA programs, has contributed to significant reductions in motor vehicle related crashes, fatalities, and injuries since its launch in 1978, with annual passenger vehicle occupant fatalities in the United States falling

from 32,043 to 26,325 from 2001 to 2021.¹ Unfortunately, this reduction was not universal in all categories of fatalities and injuries with annual pedestrian fatalities increasing by 51 percent during the same time frame, from 4,901 to 7,388.² While vehicle-to-pedestrian crashes are not as common as vehicle-to-vehicle crashes, they are significantly more deadly, with an estimated 53 out of 1000 vehicle-to-pedestrian crashes resulting in a pedestrian fatality.³ In comparison, an estimated 2.6 out of 1000 vehicle-to-vehicle crashes resulted in a fatality.

Despite improvements in automotive safety since NCAP's implementation, far more work must be done to reduce the continued high toll to human life both in and outside the vehicle on our nation's roads and to encourage safety improvements. NCAP is one of several NHTSA programs that advance the Agency's mission to reduce fatalities, injuries, and economic losses on U.S. roadways. Historically, features rated or otherwise included in NCAP have focused largely on the protection of occupants in motor vehicles. However, NHTSA has also recognized the importance of protecting other vulnerable road users (VRUs), such as pedestrians, from injury and death due to motor vehicle crashes. NHTSA published a request for comments (RFC) notice on May 26, 2023 (May 2023 RFC)⁴ proposing to add a crashworthiness pedestrian protection program to NCAP to help address the rising number of fatalities and injuries to pedestrians. The RFC notice proposed largely adopting the devices and assessment methods used in the European New Car Assessment Programme (Euro NCAP)⁵ that simulate a pedestrian being struck in the side by a vehicle traveling at 40 km/h (25 mph). However, instead of implementing a comparative rating system for pedestrian protection as Euro NCAP does, NHTSA proposed to initially identify new model year vehicles that meet a specified minimum safety threshold and then transition to a new

¹ Traffic Safety Facts 2021, "A Compilation of Motor Vehicle Traffic Crash Data." U.S. Department of Transportation. National Highway Traffic Safety Administration.

² Ibid.

³ Swanson, E., Foderaro, F., Yanagisawa, M., Najm, W.G., & Azeredo, P. (2019, August). Statistics of light-vehicle pre-crash scenarios based on 2011–2015 national crash data (Report No. DOT HS 812 745). Table ES1—Yearly Average Statistics—Scenario Groups Based on 2011–2015 FARS and GES. Washington, DC. National Highway Traffic Safety Administration.

⁴ 88 FR 34366.

⁵ <https://www.euroncap.com/en>.

rating system as discussed later in this section.

NHTSA received over 2,800 comments on the May 2023 RFC notice. Commenters included vehicle manufacturers, safety advocates, trade groups, research organizations, and individuals. Commenters broadly expressed support for NHTSA's focus on pedestrian safety, although many comments did not directly respond to the questions asked in the notice.

After careful consideration of all comments received and applicable regulatory considerations, NHTSA is largely adopting the May 26, 2023, proposal with some updates based on comments received. This NCAP update will test vehicles using four test devices used in Euro NCAP Pedestrian Testing Protocol, Version 8.5: adult and child headforms (representative of the weight of an adult and child head), the Transport Research Laboratory (TRL) upper legform, and the Flexible Pedestrian Legform Impactor (FlexPLI) lower legform.⁶ The test devices simulate body regions commonly injured in vehicle-to-pedestrian crashes and have successfully been used in Euro NCAP. This update also adopts the majority of Euro NCAP's pedestrian crashworthiness assessment methods, including the injury limits for each test device and the method in which scores for each impact point are calculated. For pedestrian crashworthiness, NHTSA also deviates from its longstanding practice of giving NCAP credit for crashworthiness features based on testing conducted by NHTSA. Historically, NHTSA would give credit in NCAP and assign ratings based on testing conducted by the agency, not data provided by manufacturers. Similar to the Agency's current NCAP crash avoidance credit system, vehicle manufacturers will provide data to demonstrate their vehicle models' performance when subjected to the pedestrian impact tests. NHTSA will perform verification tests on select vehicles to corroborate manufacturers' data. In the Agency's experience, this methodology has proven effective at driving improvements in safety performance.

NHTSA is not implementing a comparative rating system for crashworthiness pedestrian protection at this time and, instead, will identify new model year vehicles that meet a certain minimum safety threshold on the Agency's website and in other

⁶ The terms "headform" and "legform" are used to describe the pedestrian head and leg test devices, which are general representations of human heads and legs. The head and leg test devices are described in greater detail later in this notice.

published literature. This pass-fail assessment approach is intended to be temporary and eventually will be replaced with a more refined comparative rating approach in the future when other planned updates will be implemented. These updates include new program elements in crashworthiness and crash protection as well as changes to the safety information section on the Monroney label—as described in the NCAP roadmap.⁷

A. Legal and Policy Considerations

NHTSA established NCAP in 1978 in response to Title II of the Motor Vehicle Information and Cost Savings Act of 1972. At that time, the program provided consumers with frontal impact crashworthiness information to assist them in their vehicle purchasing decisions. Over the years, NHTSA has expanded the type of safety information provided to consumers and now publishes side impact crashworthiness, rollover propensity, and advanced technology information. As vehicle safety and consumer interest evolves, so, too, do the components of NCAP.

In finalizing its decisions for this notice, in addition to comments received, the Agency sought to address requirements in the 2021 Bipartisan Infrastructure Law, enacted as the Infrastructure Investment and Jobs Act, and the U.S. Department of Transportation's National Roadway Safety Strategy initiative. These considerations are described below.

1. 2021 Bipartisan Infrastructure Law (BIL)

Section 24213(b) of the BIL requires NHTSA to add information about VRU safety to NCAP to (i) determine which technologies shall be included, (ii) develop performance test criteria, (iii) determine distinct ratings for each technology, and (iv) update the overall vehicle rating to incorporate the new technology ratings in the public notices.

In response to these requirements, NHTSA published an RFC in March 2022 that proposed, among other things, adding Pedestrian Automatic Emergency Braking (PAEB) to NCAP. By applying the established inclusion criteria in the adoption of PAEB technology and the applicable test procedures and evaluation criteria included in the March 2022 notice, two of the four requirements for the Vulnerable Road User Safety portion of Section 24213(b) will be met upon the publication of this final decision notice.

⁷ <https://www.nhtsa.gov/document/ncap-roadmap>.

Further, in May 2023, the Agency published an RFC notice proposing to update NCAP by providing consumers with information about crashworthiness pedestrian protection of new vehicles. This final decision notice adds crashworthiness pedestrian protection safety technology evaluations into NCAP. As this notice identifies the specific technologies for inclusion and describes the performance test criteria NHTSA will use to evaluate these technologies, it further fulfills parts (i) and (ii) of Section 24213(b) of the BIL with respect to VRU safety.

NHTSA will fulfill the remaining requirements of Section 24213(b) when it proposes and finalizes a new rating system for the crash avoidance technologies in NCAP, updates the current crashworthiness rating program, and proposes and finalizes an overall vehicle rating that incorporates crash avoidance and crashworthiness technology evaluations.

2. 2022 U.S. Department of Transportation (DOT) National Roadway Safety Strategy (NRSS)

DOT published the NRSS in January 2022. The NRSS announced key planned departmental actions aimed at significantly reducing serious roadway injuries and deaths to reach the Department's long-term zero roadway fatalities goal. At the core of the NRSS is the department-wide adoption of the Safe System Approach, which focuses on building layers of protection to both prevent crashes from happening and minimize harm when crashes do occur.

With respect to NCAP, the NRSS supports program updates emphasizing safety features protecting people both inside and outside the vehicle. These safety features may include consideration of pedestrian protection systems, better understanding of impacts to pedestrians (e.g., specific considerations for children), and automatic emergency braking and lane keeping assistance to benefit bicyclists and pedestrians. The program also works to identify the most promising vehicle technologies to help achieve NRSS's safety goals, such as alcohol detection systems and driver distraction mitigation systems. In addition, the NRSS includes a 10-year roadmap for the program and lists as a key departmental action the initiation of a rulemaking to update the vehicle Monroney label.⁸ As part of that

⁸ The Monroney label, often referred to as the "window sticker," is a label affixed to new automobiles containing the manufacturer's suggested retail price and other consumer information as specified at 15 U.S.C. 1231–1233.

process, the Agency may also consider including information on features that mitigate safety risks for people outside of the vehicle.

Today's final decision notice presents NHTSA's continuing actions towards the implementation of this broad, multi-faceted safety strategy for NCAP that includes improved road safety for VRUs.

II. Summary of Updates to NCAP

A brief summary of the updates to NCAP included in this final decision notice is provided below.

A. Adopted Testing Devices

NHTSA will test vehicles using four test devices historically used in Euro NCAP: adult and child headforms (representative of the mass of an adult and child head), the Transportation Research Laboratory (TRL) upper

legform, and the Flexible Pedestrian Legform Impactor (FlexPLI) lower legform, discussed in detail in section VI below. The Agency will also adopt most of Euro NCAP's pedestrian crashworthiness test and assessment methodology,^{9 10} including the injury limits for each test device and the methods used for calculating scores for each impact point.¹¹ NHTSA will identify new model year vehicles that meet a certain minimum safety threshold on the Agency's website and in other published literature.

B. Adopted Test Procedures

The adopted pedestrian protection testing will evaluate the potential risk of head, upper leg, lower leg, and knee injuries to pedestrians hit by the front of vehicles. The agency expects that vehicles that score well in these tests

will do so by using designs that absorb energy, reduce hard points of contact, and include a front-end profile that will cause less injury to a pedestrian in a crash.

The crashworthiness pedestrian protection test procedures described in this final decision notice consist of standardized instructions to (1) prepare a vehicle for testing, (2) conduct impact tests using various test devices, and (3) assess a vehicle's performance based on the result of the impact tests. Vehicles will first be prepared by measuring and marking the front end of the vehicle in a prescriptive way to locate the test boundaries and impact points on the vehicle. Points on the hood for the specific "Wrap Around Distance" measurements are marked, as shown in Figure 1.¹²

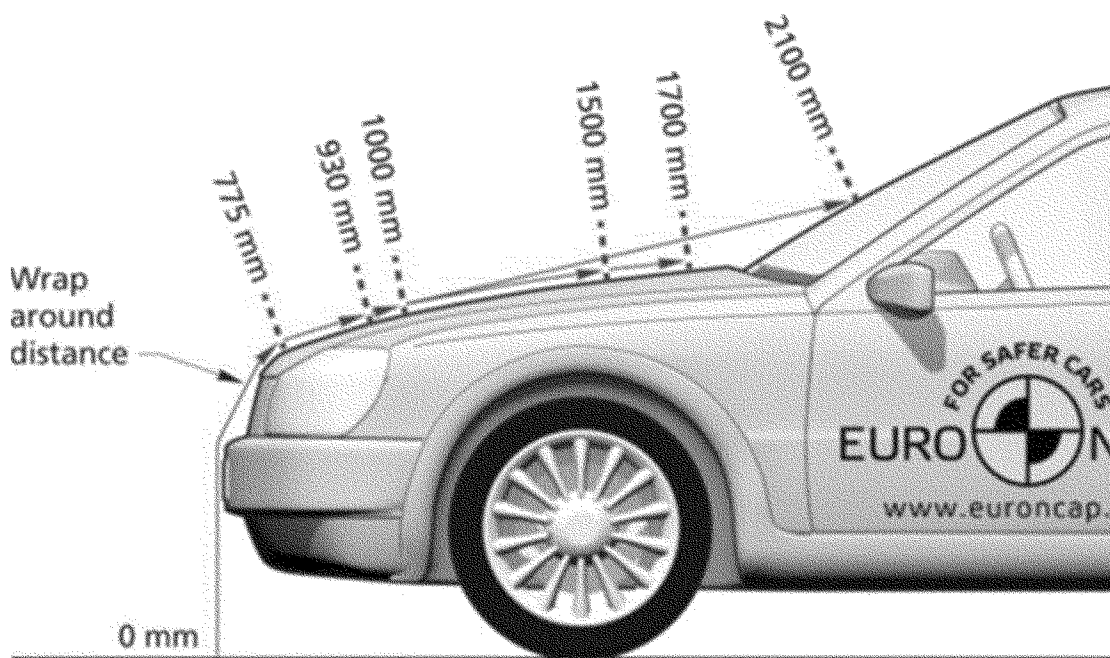

Figure 1: Wrap Around Distance (WAD)¹³

The impact points will be marked on a 100 mm by 100 mm grid on the hood, windshield, and surrounding components for the head impact tests; in a line along the hood (or bonnet) leading edge every 100 mm for the impact tests at a WAD of 775 mm (WAD775) using

the TRL upper legform; and in a line along the front bumper every 100 mm for the lower leg to bumper impact tests using the FlexPLI.

NHTSA is adopting the Euro NCAP procedure for preparing and launching a test device at a marked impact point—specifically, the adult and child headforms for the hood and windshield area points, the TRL upper legform for

the WAD775 points, and the FlexPLI for the bumper impact points.

C. Adopted Component Scoring Method

The vehicle's performance will be scored based on the resulting injury assessment values from each impact test. For the TRL upper legform and FlexPLI impacts, the scoring will be based on a sliding scale between the

Notably, the Monroney label contains safety rating information generated under NCAP.

⁹ European New Car Assessment Programme (Euro NCAP) (October 2018), *Euro NCAP Pedestrian Testing Protocol, Version 8.5*.

¹⁰ European New Car Assessment Programme (Euro NCAP) (June 2020), *Euro NCAP Pedestrian Protocol—Vulnerable Road User Protection, Part 1—Pedestrian Impact Assessment, Version 10.0.3*.

¹¹ For a summary of the differences between Euro NCAP's assessment protocols and NHTSA's procedure, see Table B1 in Appendix B. These differences are also described in more detail later in this notice.

¹² The term "Wrap Around Distance" (WAD) is a distance measurement made using a flexible tape measure along the front of the vehicle, as shown below in Figure 1. One end of the tape is held at

ground level directly below the bumper. The other end is wrapped around the front end of the vehicle and held taut while in contact with a point on the hood or windshield.

¹³ Copyright Euro NCAP 2018. Reproduced with permission from Euro NCAP Pedestrian Testing Protocol V8.5 Figure 9.

highest value of an injury measure (resulting in a score of 0) and the lowest value of the injury measure (resulting in a maximum score). For the headform impacts, the scoring will be based on discrete ranges of Head Injury Criteria (HIC₁₅) values resulting in a score of either 0.000, 0.250, 0.500, 0.750, or 1.000 points. The scores from each group of component tests (headform, upper leg, and lower leg) will be

combined to provide a crashworthiness pedestrian protection score for the tested vehicle.

A summary of the tests using the four adopted test devices is shown in Tables 1–3, including applicable WAD and injury assessment values. The Euro NCAP Assessment Protocol—Vulnerable Road User Protection, Part 1—Pedestrian Impact Assessment, Version 10.0.3, June 2020 document further

describes the injury limits and scoring process for the crashworthiness pedestrian protection impact tests outlined in this notice. Details for each of these tests, devices, and impact locations can also be found in Euro NCAP’s Pedestrian Testing Protocol Version 8.5, October 2018, and certain details are discussed later in this notice.

TABLE 1—ADULT AND CHILD HEADFORM TESTING SUMMARY

	Adult headform test	Child headform test
Impact Velocity	40 km/h	40 km/h.
Impact Angle (From Horizontal)	65 deg	50 deg.
WAD	* 1500/1700–2100 mm	** 1000–1500/1700 mm.
HIC ₁₅ (Maximum Score)	650	650.
HIC ₁₅ (Zero Score)	1700	1700.

* Points rearward of the bonnet rear reference line (BRRL) between WAD1500 and WAD1700 and up to WAD2100 are assessed using the adult headform.

** Where the bonnet rear reference line is between WAD1500 and WAD1700, points forward of and directly on the bonnet (hood) rear reference line (BRRL) are assessed using the child headform. Where the BRRL is rearward of WAD1700, the child headform is used up to and including 1700 mm.

TABLE 2—UPPER LEGFORM TESTS AT WAD 775 mm

Impact Velocity	20–33 km/h*.
Sum of Forces (Maximum Score)	5000 N.
Sum of Forces (Zero Score)	6000 N.
Bending Moment (Maximum Score)	285 Nm.
Bending Moment (Zero Score)	350 Nm.

* The exact impact velocity is calculated based on the vehicle’s geometry.

TABLE 3—FLEXPLI LOWER LEGFORM TESTS

[For bumpers with lower bumper reference line¹⁴ 500 mm or less]

Impact Velocity	40 km/h.
Ground Clearance	75 mm.
Tibia Bending Moment (Maximum Score)	282 Nm.
Tibia Bending Moment (Zero Score)	340 Nm.
Medial Collateral Ligament (MCL) Elongation (Maximum Score)	19 mm.
Medial Collateral Ligament (MCL) Elongation (Zero Score)	22 mm.
Anterior and Posterior Cruciate Ligaments (ACL/PCL) Elongation*	10 mm.

* ACL and PCL elongations act as modifiers. If the stated limit is exceeded, that impact is awarded zero points regardless of the MCL or Tibia results.

D. Adopted Procedure for Manufacturer-Submitted Data

In order to receive crashworthiness pedestrian protection credit, a manufacturer must submit the results from its own testing to NHTSA in accordance with NHTSA’s specified procedures.¹⁵ NHTSA will accept predicted (simulated) results for the head and leg impacts on condition that the manufacturer also provides evidence of physical impact testing to verify the models used for the predicted data.

¹⁴ The lower bumper reference line is the geometric trace between the bumper and a straight edge at a 25-degree forward incline.

¹⁵ This submission form will be specified at a later date.

E. Verification Testing Process

NHTSA is implementing a verification testing process for the crashworthiness pedestrian protection program similar to that used for the crash avoidance testing program in NCAP.¹⁶ For each new model year,

¹⁶ The NCAP crash avoidance safety testing program highlights vehicles equipped with certain advanced driver assistance system technologies if the vehicles meet NHTSA’s system performance test criteria. Unlike the NCAP crashworthiness safety program, the crash avoidance safety program uses test data reported by vehicle manufacturers to determine whether a vehicle meets system performance criteria set forth under NCAP and awards credit as applicable. Each year, a certain number of advanced driver assistance systems are selected and tested to verify system performance as part of the NCAP crash avoidance safety testing program.

NHTSA will select and acquire vehicles for NCAP testing. For its crashworthiness pedestrian protection verification testing, NHTSA will select and test 10 head impact points and all necessary upper leg and lower leg impact test locations on each vehicle.¹⁷ The resulting NCAP data for head impacts will be compared to the manufacturer’s submitted test data results to determine any needed

¹⁷ NHTSA will utilize the concepts of symmetry and adjacency to determine the impact test points for upper leg and lower leg impact testing across the vehicle width. To reduce test burden, the test assumes that a vehicle’s front end is symmetrical, and thus the test result on a specific point on one side of the vehicle will also be applied to the corresponding point on the other side of the vehicle. Likewise, an untested point would receive the same score as the lowest scored adjacent point.

correction factor to apply to the entire head impact test data set.¹⁸ The NCAP data for the upper leg and lower leg tests will replace the manufacturer’s provided data.

F. Adopted Vehicle Scoring Apportionment

The overall crashworthiness pedestrian protection score will combine the results from the headform tests, the upper legform tests, and the lower legform tests with a maximum score of 36.000 points. The scoring distribution is as follows: 18.000 points (50 percent) are allocated to test results using the adult and child headforms, 9.000 points (25 percent) are allocated to the test results using the TRL upper legform, and 9.000 points (25 percent) are allocated to the test results using the FlexPLI (Table 4).¹⁹ For vehicle models that receive an overall score of 21.600 (60 percent) or greater, the Agency will grant credit by providing a checkmark (or similar notation) on its website, <http://www.NHTSA.gov>. An example scoring calculation is provided in Appendix C.

TABLE 4—SCORING APPORTIONMENT SUMMARY

Body region	Apportionment (%)	Maximum possible points
Head	50	18.000
Upper Leg	25	9.000
Lower Leg	25	9.000

III. Background

NHTSA’s NCAP supports the Agency’s mission to reduce the number of fatalities and injuries that occur on U.S. roadways by providing important vehicle safety information to consumers to inform their purchasing decisions. Over the years, NCAP has periodically expanded the scope of the safety information the program provides to consumers, including through the incorporation of various advanced driver assistance system (ADAS) technologies in NCAP, including automatic emergency braking, and highlighted those technologies (via the

¹⁸The correction factor is determined based on the process described in Euro NCAP’s Assessment Protocol—VRU Protection v-10.0.3.

¹⁹NHTSA proposed in the RFC a scoring apportionment that aligned with the relative frequency of AIS 3+ injuries to the body regions in the U.S. Out of possible 36.0 points, 13.5 were allocated to head impacts, 13.5 points for lower leg impacts, and 9.0 points for upper leg impacts. NHTSA revised the scoring apportionment in this final decision notice to provide more emphasis on head impacts and approach alignment with Euro NCAP’s current scoring apportionment. Details of the justification are provided in Section VI.

Agency’s website) if they meet NHTSA’s system performance criteria. In May 2023, the Agency published an RFC proposing to expand the NCAP program by providing consumers with information about crashworthiness pedestrian protection for new vehicles to spur protection for those outside of the motor vehicle, with a particular focus on pedestrian safety.

The proposal included the addition of a testing program simulating a pedestrian being struck in the side by a vehicle traveling at 40 km/h (25 mph), with data gathered to assess injury potential to the pedestrian’s head, upper leg, and lower leg. The proposed test and evaluation procedures included the use of four pedestrian test device impactors: adult headform, child headform, the TRL upper legform, and the FlexPLI lower legform. NHTSA proposed to carry out testing in the manner described in the Euro NCAP pedestrian test protocols,²⁰ with some differences explained in the RFC notice.

According to the procedure outlined in the RFC notice, vehicles would first be prepared by measuring and marking the front end of the vehicle in a prescriptive way to locate the test boundaries and impact points on the vehicle. The boundaries for testing with different impactors would be established at discrete WAD measurements.

The impact points would be marked on a 100 mm by 100 mm grid on the hood, windshield, and surrounding components for the head impact tests; in a line along the hood (or bonnet) leading edge every 100 mm for the upper legform impact tests; and in a line along the front bumper every 100 mm for the FlexPLI lower legform impact tests. The test procedures would provide instructions on how to prepare and launch the test devices at the predetermined impact points—specifically, the adult and child headforms for the hood and windshield area points, the TRL upper legform for the hood leading edge points, and the FlexPLI for the lower leg impact points. Finally, the procedures would describe how a vehicle is scored based on the resulting measurements collected from each impact test.

In general, the proposed test protocols for hood impact tests using the adult and child headforms and the impact tests using the FlexPLI and the TRL

²⁰ <https://www.euroncap.com/en/for-engineers/protocols/vulnerable-road-user-vru-protection/>. See “Pedestrian Test Protocol” Version 8.5 and Part I of the “Assessment Protocol—VRU” Version 10.0.3. Part II of the “Assessment Protocol” and the “AEB VRU Test Protocol” do not apply and are not part of this proposal.

upper legform are similar to that of Euro NCAP. However, the May 2023 RFC proposed some adjustments to the Euro NCAP testing protocol to better reflect pedestrian protection provided by the front end of vehicles in the U.S., improve test practices, and align with the self-reporting aspect of the proposed crashworthiness pedestrian protection program.

NHTSA invited comments on the proposed test procedures and their applicability to the new U.S. vehicle fleet, test zone markup procedure, biofidelity and maintenance of test impactors, scoring method, and pass/fail assessment. The following sections provide details of certain aspects of the proposal for which comments were sought.

IV. Summary of General Comments on Proposed NCAP Updates

NHTSA received over 2,800 comments from vehicle manufacturers, safety advocates, trade groups, research organizations, and individuals in response to the May 2023 RFC notice. While many comments were not direct responses to the questions asked in the notice, they broadly expressed support for NHTSA’s focus on pedestrian safety. Many commenters urged NHTSA to incorporate more VRU-focused safety initiatives beyond crashworthiness pedestrian protection into NCAP, including driver direct visibility evaluation and information pertaining to vehicle weight. Commenters also urged NHTSA to include safety measures for VRUs other than pedestrians, including bicyclists, wheelchair users, and people on scooters. Additionally, many commenters emphasized the importance of pedestrian crash avoidance systems such as PAEB and other ADAS technologies.

Many comments from private citizens and advocacy groups such as America Walks, AARP, Action Committee for Transit (ACT), Center for Auto Safety (CAS), National Safety Council (NSC), Advocates for Highway and Auto Safety (Advocates), and the National Association of City Transportation Officials (NACTO) shared similar sentiments for increasing stringency, updating the 5-star rating system and the Monroney label, implementing a matching Federal Motor Vehicle Safety Standard (FMVSS), and voicing dissatisfaction with the manufacturer self-reporting system. Advocacy groups recommended directing research to improve understanding of female injury tolerances and representative test devices, testing at increased impact speeds, and aligning test layout and

procedures to maximize the tested area of vehicles. In general, the advocacy groups and individual citizens who provided comments were supportive of NHTSA's decision to include a crashworthiness pedestrian protection program within NCAP.

Vehicle manufacturers and groups representing vehicle manufacturers, including the Alliance for Automotive Innovation (Auto Innovators), Automotive Safety Council (ASC), Ford Motor Company (Ford), General Motors (GM), American Honda Motor Company (Honda), Hyundai Motor Company (Hyundai), Rivian Automotive (Rivian), Tesla, and Volkswagen Group of America (VW), recommended harmonizing with Euro NCAP procedures to the greatest extent possible. These comments included such recommendations as the adoption of the advanced pedestrian legform impactor (aPLI) in the long term, test device qualification procedures, test zone layout, test procedures, documentation, point apportionment, and results reporting. Overall, the vehicle manufacturers that provided comments were supportive of NHTSA's decision to include a crashworthiness pedestrian protection program within NCAP.

The Agency has summarized the sections of the RFC, comments from the public, and the Agency's responses to those comments into the following categories: test zone and markup, test devices, test procedure, data acquisition and reporting, and other comments. These summaries, comments, and NHTSA's responses are discussed in the remainder of this notice.

V. RFC Comments and Agency Decision

A. Test Zone and Markup

1. RFC Summary

NHTSA requested comments on specific test zone details and markup procedures for the vehicles to be tested. The U.S. vehicle market differs from the European vehicle market; therefore, NHTSA raised questions concerning

some of these potential differences. As a response to design trends caused by the Euro NCAP test protocol, NHTSA also requested comments on how the bumper test width is defined. Before delving into specific comments, the Agency believes that outlining some key details regarding the test zone and markup is important. Further detail on bumper corner definition, WAD limit, vehicles with a lower bumper reference line (LBRL)²¹ greater than 500 mm, and artificial interference is provided in the following sections.

a. Bumper Corner Definition

For the lower legform impact tests, the FlexPLI is launched parallel to the travel direction of the vehicle. The intended impact points are spread laterally along the vehicle's bumper test zone. The bumper test zone extends across the front of the vehicle to either the bumper corners on each side or the full width of the bumper beam, whichever is larger.

There are currently two existing procedures for determining the bumper corners: (1) the 60-degree angle method specified in Euro NCAP and (2) the corner gauge method specified in European regulation UN ECE R.127, "Uniform provisions concerning the approval of motor vehicles with regard to their pedestrian safety performance" (UNECE R127)²² and Global Technical Regulation No. 9, "Pedestrian Safety" (GTR 9).²³ Euro NCAP uses a vertical plane at a 60-degree angle to the vehicle's centerline to mark the bumper corner (as shown in Figure 2). Euro NCAP then compares this width to that of the bumper beam, a load bearing structure underlying the fascia, then tests the larger of the two areas. In Europe, the use of the 60-degree angle

method has resulted in a design trend in which "touch points" are molded into the lower portion of the fascia to contact the 60-degree plane in a manner that could reduce the bumper test area. NHTSA found that in some vehicle designs, the bumper test area is reduced to as little as 40 percent of the vehicle width when using the 60-degree angle method. When the bumper test area is reduced in this manner, a smaller portion of the vehicle's front end is tested for pedestrian protection. From a safety perspective, a larger bumper test area is preferred as it allows the Agency to determine the crashworthiness pedestrian protection performance for more of the vehicle's front end.

²¹ The LBRL is defined as the geometric trace between the bumper and a straight edge at a 25-degree forward incline.

²² The United Nations Economic Commission for Europe, Regulation No. 127, "Motor Vehicles Pedestrian Safety Performance."

²³ <https://unece.org/transport/standards/transport/vehicle-regulations-wp29/global-technical-regulations-gtrs>.

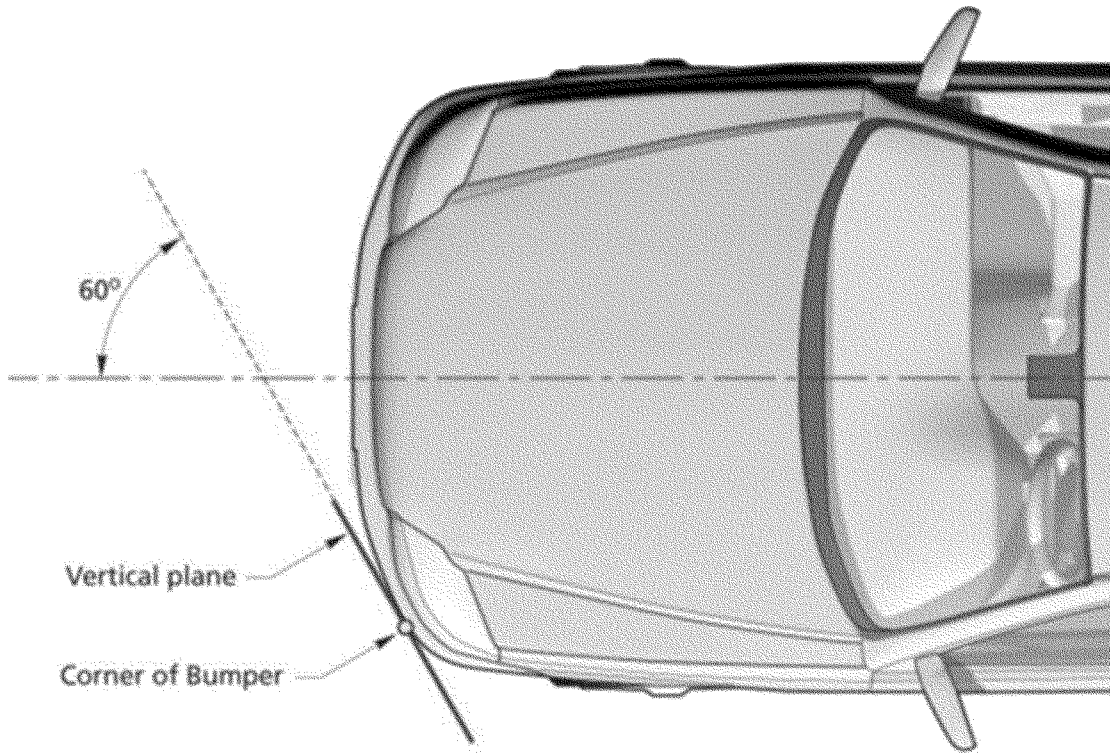

Figure 2: 60-Degree Angle Method Specified in Euro NCAP

In contrast, UNECE R127 and GTR 9 regulations use a corner gauge method, which employs a corner gauge device as shown in Figure 3. The corner gauge method identifies the corner of the

bumper by locating the outermost point of contact with the gauge when it is moved parallel to a vertical plane with an angle of 60 degrees to the vertical longitudinal center plane of the vehicle, as illustrated in Figure 4. UNECE R127's definition of the bumper test area also includes a specification to ensure that

the entire width of the stiff bumper beam is included in the test area. In the May 2023 RFC notice, NHTSA stated that it tentatively plans to use the corner gauge method and bumper beam width comparison procedure for the bumper corner definition.

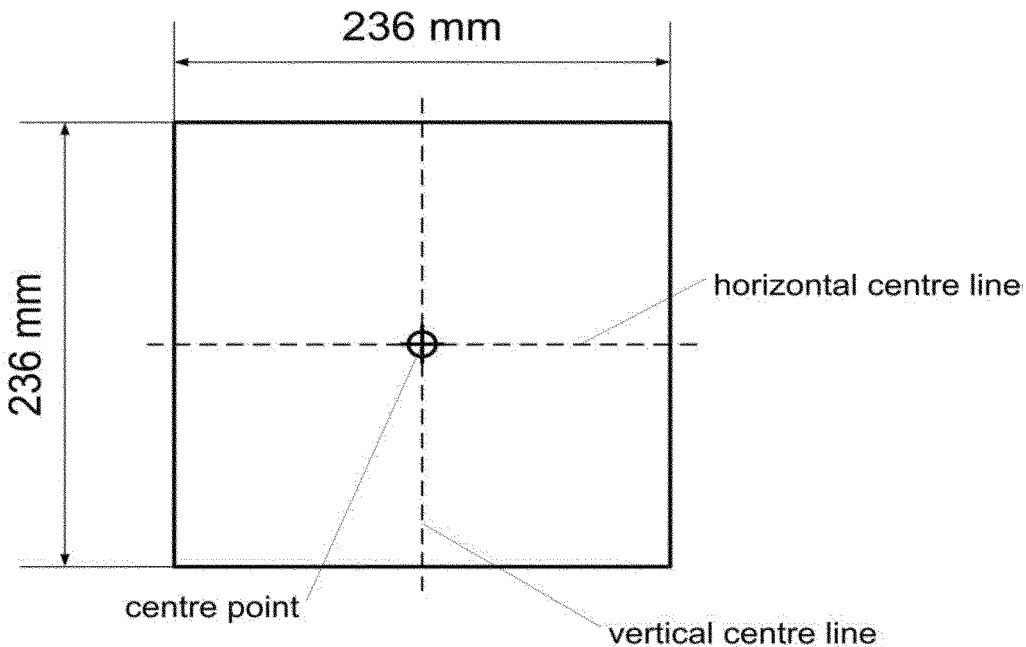
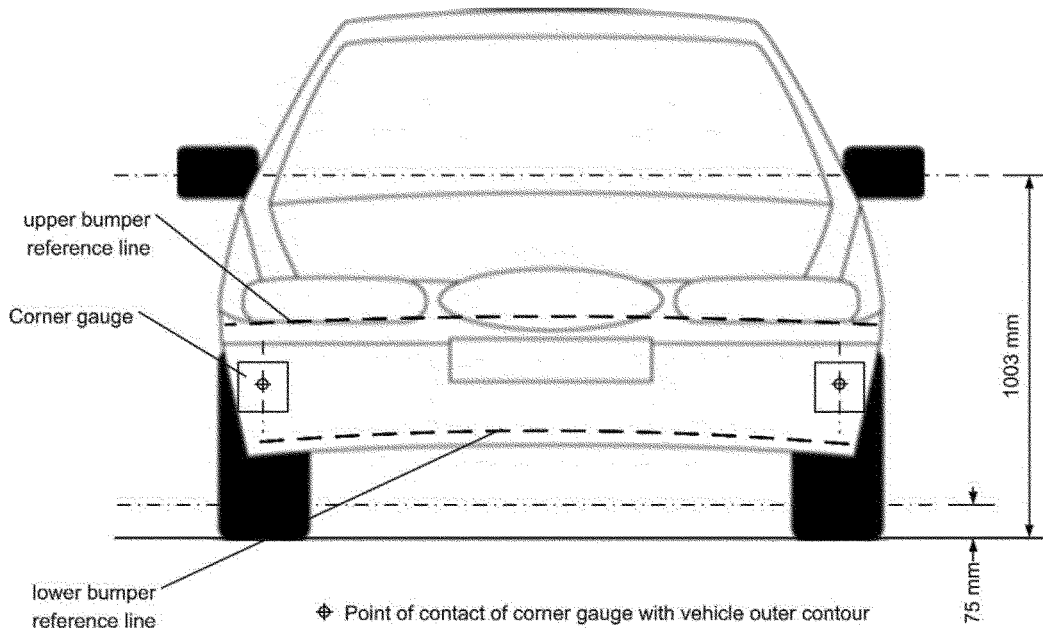

Figure 3: Bumper Corner Gauge²⁴Figure 4: Determination of Bumper Corner With Corner Gauge²⁵

As originally brought to NHTSA's attention by GM, trucks and other large vehicles with exposed metal bumpers may warrant additional consideration based on the bumper test zone determination procedure above. For vehicles with exposed bumpers, NHTSA requested comments on whether the full width of the exposed bumper should be tested, or if the same corner definition method as non-exposed bumpers should be used. These exposed bumpers are often stylized and may be swept back at the outboard edges. These characteristics would likely result in inaccurate measurements when impacted with the FlexPLI if the impact angle is greater than 60 degrees. For vehicles with non-exposed bumpers, NHTSA proposed using the corner gauge method and bumper beam width test procedure.

b. WAD Limit

As previously mentioned, the term "Wrap Around Distance" (WAD) is a

distance measurement made using a flexible tape measure along the front of the vehicle. One end of the tape is held at ground level directly below the bumper. The other end is wrapped around the front end of the vehicle and held taut and in contact with a point on the hood or windshield. The maximum WAD in Euro NCAP's Pedestrian Testing Protocol Version 8.5 for an adult male is 2100 mm. However, UNECE R127 Feb 2023 amendments include increasing the WAD limit from 2100 mm to 2500 mm. Additionally, these amendments include tests on the parts of the windshield that are within this limit. Euro NCAP's most recent version of its testing protocol, Version 9.1, has also increased the maximum WAD to 2500 mm. In the RFC, NHTSA requested comment on whether NCAP should also raise the WAD limit to account for pedestrians who may overshoot the vehicle when struck at a higher speed. This change would assess the vehicle's ability to provide protection to VRUs in a wider variety of crashes.

c. Vehicles With LBRL Greater Than 500 mm

The LBRL is the lower boundary of significant points of contact between a pedestrian leg and the bumper when a vehicle's front bumper makes contact with a pedestrian. The LBRL is determined with a 700 mm long straight edge held at a 25-degree angle from the vertical against the front of the vehicle, as illustrated in Figure 5. The FlexPLI has a poor kinematic response when testing a vehicle with an LBRL greater than 500 mm.²⁶ If a FlexPLI test is conducted on such a bumper, the legform's lack of an upper body structure could result in a condition where, upon impact, it is redirected groundward with very little tibia bending and knee displacement, thus leading to an artificially high test score. Such kinematics do not accurately represent a human-to-vehicle interaction.

²⁴ Reproduced from GTR 9 Amendment 2 Figure 5B.

²⁵ Reproduced from GTR 9 Amendment 2 Figure 5C.

²⁶ See "Rationale for limiting the lower legform test," paragraph 99 of GTR 9.

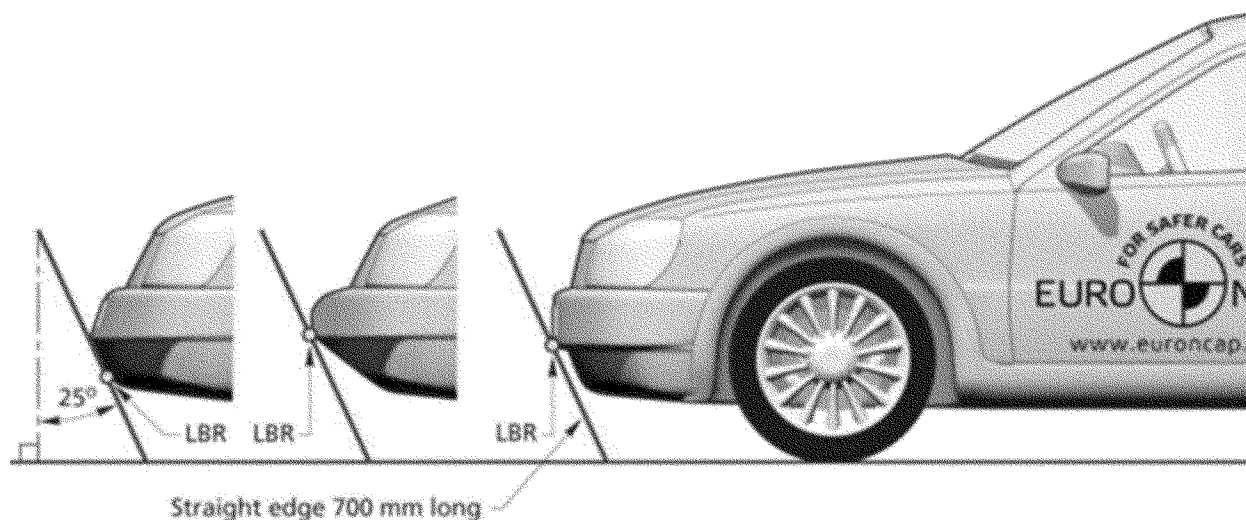

Figure 5: Marking the Lower Bumper Reference Line (LBRL)²⁷

Euro NCAP performs bumper impact tests on vehicles with an LBRL greater than 500 mm using the TRL upper legform. For vehicles with an LBRL of 425 mm to 500 mm, Euro NCAP gives the manufacturer the option of using either the TRL upper legform or the FlexPLI. However, for vehicles with an LBRL of 425 mm to 500 mm, NHTSA proposed to only use the FlexPLI.²⁸ Additionally, the Agency proposed not testing bumper locations where the LBRL is greater than 500 mm for lower

²⁷ Copyright Euro NCAP 2018. Reproduced with permission from Euro NCAP Pedestrian Testing Protocol V8.5 Figure 13.

²⁸ NHTSA noted in May 2023 RFC that the option to test with either legform (as permitted by Euro NCAP) could lead to conflicting or misleading scores since the test parameters and test devices used to generate the scorings are not the same. The Agency believes that to provide consumers with comparative vehicle safety information, vehicles should be subjected to the same test devices, testing protocols, and evaluation methods.

leg impacts, instead assigning a “default red, no points” score.²⁹

d. Artificial Interference in High-Bumper Vehicles

Euro NCAP employs an impact test along the bonnet (or hood) leading edge with the TRL upper legform impactor known as the Upper Legform to WAD775mm Test.³⁰ The WAD775 test, which is conducted at a WAD of 775 mm, simulates a pedestrian’s upper leg and hip wrapping around the front end of the vehicle in the transition area

²⁹ Note that some vehicles may have portions of the LBRL greater than 500 mm and some portions less than or equal to 500 mm. For those vehicles, the portions where the LBRL is less than or equal to 500 mm would still undergo testing, and the portions that have LBRL greater than 500 mm would receive the “default red, no points” score.

³⁰ See Euro NCAP Pedestrian Testing Protocol V8.5 Section 11, “Upper Legform to WAD775mm Tests” for instructions for carrying out the upper legform to WAD775 test. <https://cdn.euroncap.com/media/41769/euro-ncap-pedestrian-testing-protocol-v8.5.201811091256001913.pdf>.

between the bumper and the hood. Because the pedestrian’s hip wraps around the front end of the vehicle, the upper legform impactor is set up to strike the vehicle perpendicular to a line connecting the internal bumper reference line (IBRL)³¹ (shown in Figure 6) and a point representing WAD930 as shown in Figure 7. These tests are conducted at an impact velocity between 20 and 33 km/h (12 and 21 mph). Maximum points are awarded for forces below 5 kN and bending moments below 280 Nm. The test setup is shown in Figure 7. Vehicles with higher front ends tend to have lower impact angles (relative to horizontal) and higher impact speeds with more energy. Vehicles with lower front ends tend to have higher impact angles (relative to horizontal) and lower impact speeds with less energy.

³¹ The IBRL height is identified where a vertical plane contacts the bumper beam up to 10mm into the profile of the bumper beam.

Figure 6: Internal Bumper Reference Line³²

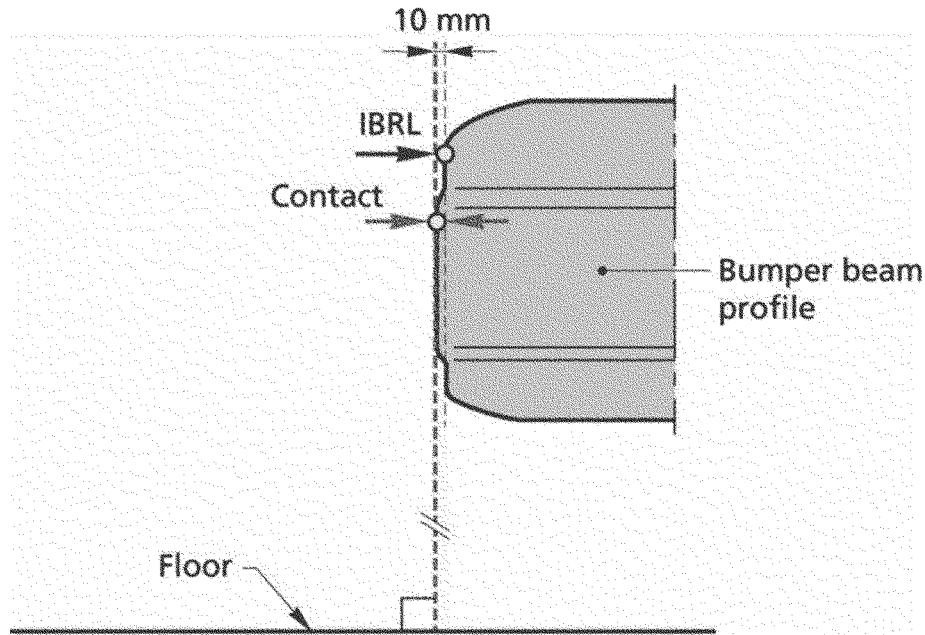
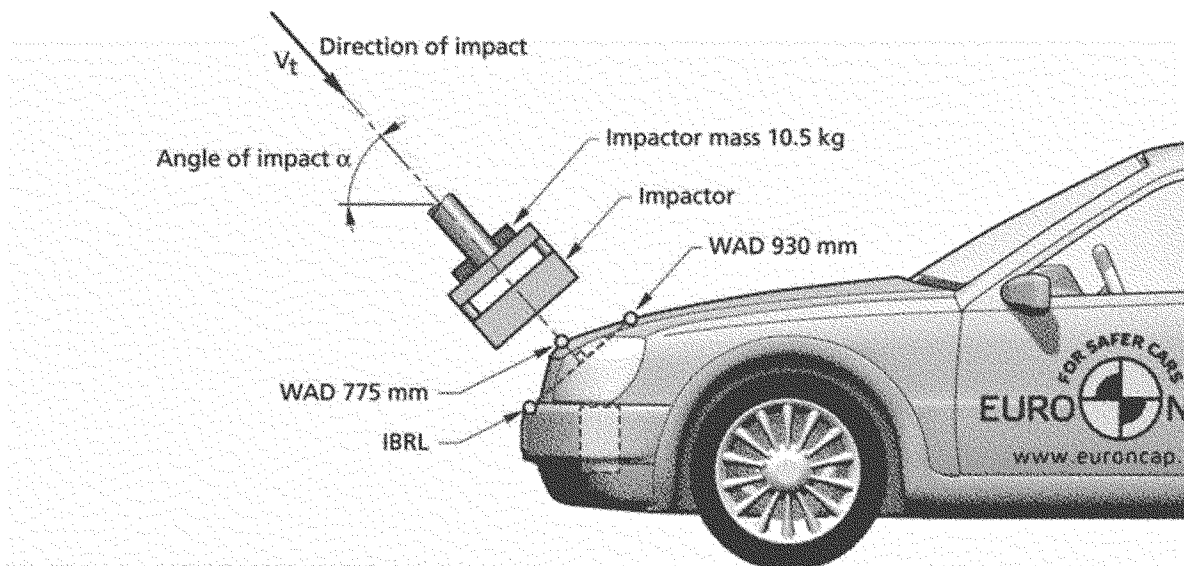

Figure 7: Upper Legform to WAD775 Test Setup³³



When testing a high-bumper vehicle, the WAD775 mark may appear on the grille of the vehicle, well below the bonnet leading edge. It could lead to a condition in which either the top or bottom edge of the TRL upper legform impactor would “catch” a protruding

vehicle component, such as the top edge of the bumper—as shown in Figure 8. When this condition occurs, the impactor may glance off the component in such a way that it can absorb a significant amount of impactor energy without registering a significant moment

or force in the instrument. NHTSA proposed repositioning the upper legform ± 50 mm away from the WAD775 target to avoid situations where artificial interference occurs.

³² Copyright Euro NCAP 2018. Reproduced with permission from Euro NCAP Pedestrian Testing Protocol V8.5 Figure 15.

³³ Copyright Euro NCAP 2018. Reproduced with permission from Euro NCAP Pedestrian Testing Protocol V8.5 Figure 29.

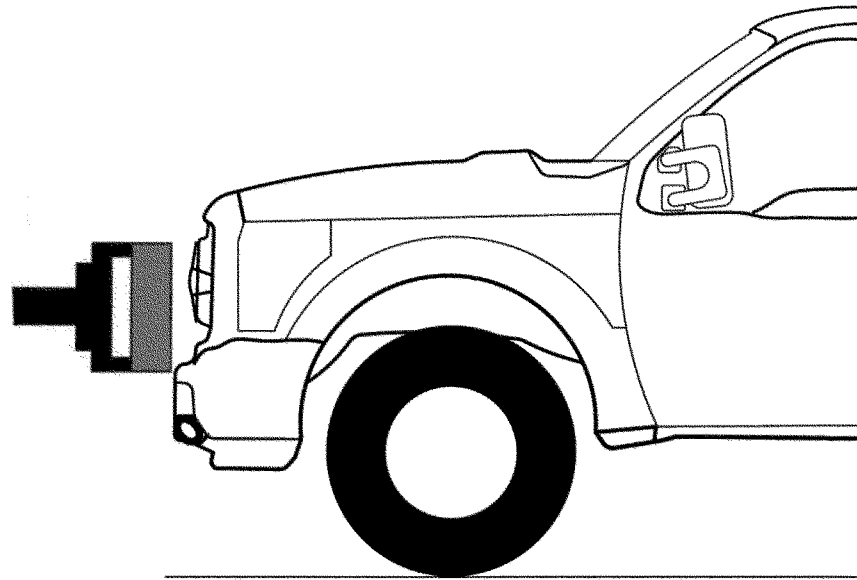

Figure 8: Example of Upper Legform to WAD775 Glancing Blow

2. Comments Received

a. Bumper Corner Definition

Humanetics, Honda, Tesla, Auto Innovators, Advocates, and individual members of the public supported the use of the corner gauge method for determining a vehicle bumper's corners. The ASC, Rivian, and Autoliv supported the Euro NCAP 60-degree angle method. The Center for Automotive Safety Research (CASR) noted that the corner gauge method and the Euro NCAP 60-degree angle method will usually result in the same location for the corner definition. Tesla reiterated the point that NHTSA made in the RFC, which is that the corner gauge method mitigates the effect of design trends of the lower portion of the fascia that could result in a significantly reduced bumper test area when using the Euro NCAP 60-degree angle method. Rivian stated that the Euro NCAP 60-degree angle method is the most effective method, and harmonization with other NCAPs is beneficial. Auto Innovators stated that the corner gauge method ensures pedestrians will be protected in a larger bumper test zone. Additionally, Auto Innovators supported NHTSA's combined proposal of using the corner gauge method and bumper beam width procedure as it enables the evaluation of a larger test zone and aligns with UNECE R127-02. Humanetics, Honda, Rivian, Consumer Reports, Tesla, and CASR also agreed that the combined approach of using the corner gauge method and bumper beam width procedure is logical.

When evaluating exposed bumpers, ASC, Honda, Autoliv, and Auto

Innovators supported using either the 60-degree angle method or the corner gauge method instead of testing the full bumper width. Auto Innovators stated that performing the lower leg impact test at the extreme width of any vehicle creates potential issues in terms of impactor response and durability and increases the possibility of glancing blows. Auto Innovators further stated the corner gauge method would be preferable to the 60-degree angle method for exposed bumpers. ACT, Rivian, CASR, and individual members of the public supported testing the full bumper width of exposed bumpers. ACT stated that pedestrians may be hit by any part of the bumper, and thus, the entire bumper should be evaluated. Multiple commenters stated that special considerations should not be given to exposed bumpers, and harmonization with the Euro NCAP should be prioritized.

b. WAD Limit

Regarding the WAD limit, many commenters supported an increase from the proposed 2100 mm to 2500 mm to harmonize with Euro NCAP and promote increased safety for other VRUs such as bicyclists whose heads may impact the bonnet/hood in a different location if struck. The ASC stated the increased WAD limit of 2500 mm would have the additional benefit of "providing protection at higher speeds when [the impacted individual] overshoots the bonnet and lower windshield areas." Conversely, several commenters, including Honda, Hyundai America Technical Center, Inc. (HATCI), and Auto Innovators, agreed with NHTSA's proposed WAD limit of 2100 mm. These commenters argued a

WAD limit of 2100 mm is reasonable and appropriate for the U.S. market, especially considering the complementary effects of PAEB, which has the effect of reducing vehicle speeds prior to impact with pedestrians. HATCI further explained that reducing vehicle speed prior to impact with a pedestrian results in a lower likelihood of the pedestrian striking the vehicle at higher WAD locations.

c. Vehicles With LBRL Greater Than 500 mm

Many advocacy groups, including AAA, AARP, ACT, CAS, and Consumer Reports, recommended not granting credit to vehicles with an LBRL greater than 500 mm, as the existing test procedure does not accurately gauge crashworthiness.

Vehicle manufacturers and the Insurance Institute for Highway Safety (IIHS) largely opposed the automatic zero score on vehicles with an LBRL greater than 500 mm, claiming it would disincentivize the development of pedestrian safety features altogether on vehicles with LBRL greater than 500 mm. Honda noted that it would be nearly impossible for vehicles with LBRL greater than 500 mm to earn an overall 60 percent score because that would require near maximum scores for the head tests (proposed in the RFC to be a 37.5 percent contribution) and upper leg tests (proposed in the RFC to be a 25 percent contribution). Honda stated that automakers would be disincentivized from providing pedestrian protection in any area for these vehicles since they would be unlikely to earn the overall minimum score (60 percent) for pedestrian protection credit.

Many automobile manufacturers including Auto Innovators, GM, Honda, and HATCI recommended testing with the aPLI, stating that the aPLI behaves in a more biofidelic manner than the FlexPLI for this test. Honda noted that adopting the aPLI legform would allow testing vehicles with LBRL greater than 500 mm and thereby eliminate the issue it raised about the proposal disincentivizing pedestrian protection features in these vehicles. CASR and GM recommended testing with the upper leg impactor to harmonize with Euro NCAP.

d. Artificial Interference in High-Bumper Vehicles

Regarding NHTSA's question about repositioning the upper legform ± 50 mm from the WAD775 target when artificial interference is possible, nearly all commenters expressed opposition due to a lack of repeatability or reproducibility of the procedure. Of the nine commenters that submitted a response to this question, seven were automakers or groups representing automakers. Ford further explained its stance that the allowance of this repositioning would introduce subjectivity when test laboratories define the impact points. This subjectivity would lead to discrepancies which would require additional testing to resolve conflicts, according to Ford. Honda agreed with adjusting the upper legform position, with the stipulation that "clear definitions of this situation must be included in the protocol." Otherwise, Honda agreed with the other commenters that there would be discrepancies and conflicts among test laboratories. Additionally, multiple commenters, including HATCI and GM, suggested NHTSA conduct further analysis to determine the existence and extent of this artificial interference.

Two commenters, CASR and Advocates, agreed with the concept of NHTSA's proposal. CASR stated that the Agency should adjust testing heights when artificial interference is present "to ensure that injurious locations are adequately assessed." Advocates expressed concern that automakers would intentionally incorporate features into their vehicle front end designs to cause artificial interference to inflate their crashworthiness pedestrian protection ratings.

3. Discussion and Agency Decision

a. Bumper Corner Definition

NHTSA has decided to use the corner gauge method (as used in GTR 9 and UNECE R127) as proposed in the RFC. The corner gauge method mitigates the

effect of design trends of the lower portion of the fascia that could result in a significantly reduced bumper test area when using the Euro NCAP 60-degree angle method. NHTSA agrees with commenters stating that the corner gauge method is more likely to result in a larger bumper test area. A larger bumper test area is preferable because it allows for evaluation of a greater portion of the vehicle for crashworthiness pedestrian protection.

Most comments concerning the general procedure for determining the bumper test zone agreed that the bumper width using the corner definition should be compared to the bumper beam width, and the larger of the two widths should be used as the bumper test zone. The hard bumper beam width will be compared to the bumper width using the corner gauge method, and the larger of the two widths will be used as the bumper test zone. This methodology aligns with Euro NCAP in that both bumper beam width and bumper fascia width will be taken into account when determining the bumper test zone, and most commenters agreed that harmonization is best when possible. The only difference between this method and Euro NCAP is that Euro NCAP uses the 60-degree angle method in conjunction with the bumper beam width procedure. However, as discussed above, NHTSA determined the corner gauge method is preferable to the 60-degree angle method. Therefore, NHTSA will use the corner gauge method in conjunction with the bumper beam width procedure to determine the bumper test zone as proposed in the RFC.

For vehicles with an exposed bumper, using the corner gauge method would always result in the full width of the bumper beam as the bumper test width. While pedestrians may be impacted by any part of the exposed bumper like some commenters stated, testing the curved edges using the current methods would likely not result in meaningful data that could be used to improve pedestrian safety. Therefore, in the case of a vehicle with an exposed metal bumper, NHTSA will use the corner gauge method to determine the corner location and bumper test width. This method provides a consistent approach with vehicles without an exposed bumper and prevents NHTSA and test laboratories from performing wasteful impact tests where the data may not be useful.

b. WAD Limit

NHTSA has decided to use a WAD limit of 2100 mm as originally proposed. As discussed below, NHTSA

acknowledges there are potential benefits to an increased WAD limit of 2500 mm, but ongoing research must be completed before implementing this increased WAD limit for NCAP.

While some commenters agreed with NHTSA's proposed WAD limit of 2100 mm, most requested that NHTSA increase the WAD limit to 2500 mm to harmonize with Euro NCAP and provide increased protection for other VRUs. NHTSA agrees with the commenters that a WAD limit of 2500 mm would likely benefit non-pedestrian VRUs, such as bicyclists, as their heads tend to be higher off the ground than pedestrians. NHTSA also agrees with ASC's comment that an increased WAD limit may provide improved protection for VRUs impacted at slightly higher speeds as their heads may overshoot the WAD2100 limit. However, as impact speeds increase, so does the likelihood that a pedestrian's head overshoots the vehicle's hood and windshield entirely, especially in vehicles with lower front ends. Conversely, as mentioned by multiple commenters, the increased adoption of PAEB is expected to reduce vehicle speeds prior to impact with pedestrians.³⁴ These reduced impact speeds will also reduce the likelihood of the pedestrian's head impacting the hood or windshield beyond the WAD2100 limit.

Vehicles in the U.S. market are often larger and equipped with higher bumpers than European vehicles. These differences result in unique challenges from a testing perspective. NHTSA is conducting research to determine unique impact scenarios for bicyclists with vehicles in the U.S. NHTSA will use the results of this research to develop or enhance existing test procedures to assess the performance of vehicle front end structures (including the windshield area) in mitigating injuries and fatalities in crashes with bicyclists. Therefore, NHTSA will move forward with the proposed WAD limit of 2100 mm at this time, but the Agency will consider increasing to a WAD limit of 2500 mm in the future once relevant test procedures are developed.

c. Vehicles With LBRL Greater Than 500 mm

NHTSA has decided to automatically issue a score of zero for any lower legform test points on a vehicle where the LBRL is greater than 500 mm. The Agency is not aware of any existing countermeasures that would improve

³⁴ See NHTSA's final rule adopting a new Federal Motor Vehicle Safety Standard to require automatic emergency braking (AEB), including pedestrian AEB (PAEB), systems on light vehicle. 89 FR 39686 (May 9, 2024).

the lower leg safety of vehicles with an LBRL greater than 500 mm when tested with the FlexPLI. It should be noted that test points where the LBRL is below 500 mm will still be tested using the FlexPLI, even if those above 500 mm on the same vehicle will not be tested.

Multiple commenters raised concerns that an automatic zero score would disincentivize manufacturers from providing pedestrian protection because it would be nearly impossible for them to achieve the 60 percent minimum passing score without any points for the lower leg impact tests. As explained in detail later in this notice, NHTSA is adjusting the scoring apportionment for head, lower leg, and upper leg impacts to better account for injury severity. This updated scoring apportionment results in a lower apportionment for lower leg impact tests (25 percent) and a higher apportionment for head impact tests (50 percent). The updated scoring would make it possible for vehicles with LBRL greater than 500 mm to obtain overall pedestrian protection credit (60 percent), even with an automatic zero score for the lower legform tests. Therefore, manufacturers of vehicles with LBRL greater than 500 mm may develop vehicle designs that improve pedestrian protection for the upper leg and head impacts to obtain pedestrian protection credit.

NHTSA is conducting research on the suitability of the aPLI for evaluating vehicle designs to mitigate pedestrian lower extremity injuries. The Agency will also research the use of aPLI for assessing lower extremity injuries on vehicles with LBRL greater than 500 mm. As noted in the NCAP roadmap,³⁵ NHTSA plans to consider testing with aPLI starting with model year 2030 vehicles.

d. Artificial Interference in High-Bumper Vehicles

NHTSA has decided not to allow test laboratories the option of repositioning the upper legform ± 50 mm from the WAD775 target when artificial interference is present, or to conduct multiple impacts within a ± 50 mm range from the WAD775 target. The concerns about repeatability and reproducibility raised by automakers are valid, and NHTSA agrees that an objective definition for artificial interference is necessary. However, as NHTSA determined while testing a 2015 Ford F-150,³⁶ when artificial

interference occurs, it results in artificially low impact values in the upper legform impactor. The Agency wants to ensure the results of these impact tests are accurate but needs both a clear definition of the problem and a repeatable, reproducible solution to account for this situation. NHTSA will continue to evaluate the causes and effects of artificial interference. After these evaluations, the Agency may decide to further define the condition and develop a repeatable and reproducible procedure to address artificial interference during the tests.

B. Test Devices

1. RFC Summary

NHTSA requested comments on test devices, their qualification schedule, and maintenance procedures that may affect the FlexPLI's performance. NHTSA also requested comments on the existence of female-specific test devices. Details regarding the test devices are grouped into four categories: female-specific test devices, upper legform humidity tolerance, FlexPLI qualification procedures and testing, and FlexPLI biofidelity.

a. Female-Specific Test Devices

The TRL upper legform and the FlexPLI are based on a 50th percentile average adult male in both mass and stature. These legforms are the most current anthropomorphic legforms available that have been thoroughly researched and reviewed by NHTSA. NHTSA requested information on whether other legforms that represent smaller adult females are available, the injury criteria and test procedures associated with them, and the safety need for such legforms.

b. Upper Legform Humidity Tolerance

NHTSA has previously investigated the repeatability and reproducibility of the TRL upper legform by performing qualification testing and vehicle impact testing.³⁷ During this testing, NHTSA found that the foams used in the upper legform are sensitive to changes in temperature and humidity. Therefore, NHTSA requested comment on potentially using a tighter humidity tolerance than other existing international standards to improve lab-to-lab consistency.

c. FlexPLI Qualification Procedures and Testing

Regarding the FlexPLI, UNECE R127 specifies two dynamic qualification tests—a Pendulum test and an Inverse Impact test, in addition to a series of quasi-static tests. In UNECE R127, the dynamic qualification tests are performed before and throughout a test series, while the quasi-static tests are performed on an annual basis. Euro NCAP only specifies the dynamic Inverse Impact test and the quasi-static tests. NHTSA requested information on the Pendulum and Inverse dynamic tests as well as the quasi-static tests and how often they should be performed.

d. FlexPLI Biofidelity

NHTSA proposed the FlexPLI as a biofidelic impactor but requested additional information on the FlexPLI's biofidelity. Previous comments that NHTSA has received suggested that the FlexPLI demonstrates reduced biofidelity in oblique loading conditions (e.g., where there is curvature in the vehicle profile).

2. Comments Received

a. Female-Specific Test Devices

NHTSA did not receive any comments identifying female-specific impactors. Humanetics, Honda, and GM specifically noted that such impactors do not currently exist. Autoliv stated that other factors such as gait cycle and knee position have greater effect on injury risk than the pedestrian's gender, stating "ideal representation of the at-risk population includes more than pedestrian gender or stature." Several commenters including Auto Innovators and Honda recommended using the aPLI in place of the FlexPLI, stating that the aPLI is more biofidelic. Advocacy groups including the NSC, AARP, and VERITY Now recommended developing additional pedestrian test devices to better represent the diversity of the human population, including smaller stature adults and older adults.

b. Upper Legform Humidity Tolerance

The commenters that discussed the humidity tolerance, including Auto Innovators, Honda, Rivian, VW, and Tesla, recommended harmonizing with Euro NCAP guidelines, which use the UNECE R127 guidelines of 10 to 70 percent humidity. CASR noted that it aims to certify between 10 and 55 percent humidity for its testing because it has "found issues meeting requirements at humidity levels above 55 percent." Humanetics also responded, stating it certifies its upper legform to the same 10 to 70 percent

³⁵ <https://www.nhtsa.gov/document/ncap-roadmap>.

³⁶ Suntay, B., & Stammen, J. (2019, May). Technical evaluation of the TRL pedestrian upper legform (Report No. DOT HS 812 659). Washington,

DC: National Highway Traffic Safety Administration.

³⁷ <https://www.regulations.gov/document/NHTSA-2019-0112-0007>.

range used in UNECE R127 and Euro NCAP.

c. FlexPLI Qualification Procedures and Testing

Most commenters discussing FlexPLI qualification recommended using both the quasi-static test and inverse test at different frequencies. Humanetics and Honda recommended performing the quasi-static test after each disassembly or once annually, and the inverse test after every 30 vehicle impacts. Humanetics also recommended performing the pendulum test after every 10 vehicle impacts but noted that between the inverse test and the pendulum test, the inverse test is more important. Honda recommended performing the inverse test before each test series and after a maximum of 10 impacts. HATCI and GM recommended harmonizing with Euro NCAP, which performs the inverse test every 20 impacts (maximum) or every 12 months and static certification tests annually. UNECE R127 also includes the pendulum test (which Humanetics recommended).

d. FlexPLI Biofidelity

All commenters discussing FlexPLI biofidelity except for Honda commented that the FlexPLI is sufficiently biofidelic, though they also

recommended the aPLI over the FlexPLI. These commenters stated the benefits of the aPLI are increased biofidelity and/or harmonization with other NCAPs. Many commenters supported adopting the FlexPLI as a temporary measure and adopting the aPLI in the long term.

3. Discussion and Agency Decision

a. Female-Specific Test Devices

The TRL upper legform and the FlexPLI are the most current anthropomorphic legforms available that have been thoroughly researched and reviewed by NHTSA. No female-specific legform impactors were identified by any commenters. NHTSA will proceed as proposed with the TRL upper legform and the FlexPLI. As noted earlier, NHTSA is conducting research on the suitability of the aPLI for evaluating vehicle designs to mitigate pedestrian lower extremity injuries, with plans to introduce this device in NCAP tests in the future. The current aPLI is representative of a 50th percentile male lower extremity. NHTSA will consider similar devices representing a range of male and female pedestrian sizes in the future.

b. Upper Legform Humidity Tolerance

Most commenters supported a humidity range of 10 to 70 percent for

the TRL upper legform tests. NHTSA recognizes the importance of international harmonization when possible; therefore, NHTSA will proceed with a humidity range of 10 to 70 percent to harmonize with Euro NCAP. Nevertheless, NHTSA will monitor upper legform performance in cases where humidity levels are between 55 and 70 percent and will consider the possible need for a tighter humidity tolerance.

c. FlexPLI Qualification Procedure and Testing

After taking the received comments into account, NHTSA has decided to proceed with the test schedule outlined in Table 5, which prescribes the inverse impact test after every 20 impacts, the quasi-static tests once per year, and only requires the pendulum test if any lower performance limits are exceeded. This schedule aligns with Euro NCAP, except for the use of the pendulum test if any lower performance limits are exceeded.³⁸ NHTSA is choosing to use the pendulum test in these instances to accommodate labs that do not have a dedicated inverse testing fixture, since they would need to be reconfigured to perform the inverse impact test during vehicle testing.

TABLE 5—FLEXPLI QUALIFICATION TESTING SCHEDULE

Test mode	Frequency	Align with Euro NCAP?
Inverse Impact Test	After every 20 impacts	Yes.
Quasi-static Tests	Every 12 months	Yes.
Pendulum Test	If testing exceeds any lower performance limits	No.

d. FlexPLI Biofidelity

While many commenters noted the aPLI is more biofidelic than the FlexPLI, all commenters who did so also found the FlexPLI to be an acceptable interim solution while NHTSA works to implement the aPLI in a future action. As noted in NHTSA’s NCAP roadmap,³⁹ the Agency plans to begin testing with the aPLI starting with model year 2030 vehicles, pending necessary research and analysis, as it is designed to provide more biofidelic upper leg injury measurements than the FlexPLI, which will be more important for assessing vehicles with taller front ends.

C. Test Procedure

1. RFC Summary

NHTSA requested comments on Euro NCAP’s test procedures and documentation, including test speed, permitted models and simulation software, active hoods, and scoring calculation and points allocation. Comments regarding these test procedures are categorized into four groups: apportionment of scoring, test speeds, documentation, and active hood detection. A brief discussion providing more detail on each of these groups is discussed below.

a. Apportionment of Scoring

In the RFC, NHTSA proposed a scoring method that differed from the Euro NCAP scoring method regarding points apportionment. The proposed points apportionment, referred to as the 3/8th, 3/8th, 2/8th scoring method, included a maximum of 13.5 out of 36 points (37.5 percent) for head impacts, 13.5 out of 36 points (37.5 percent) for lower leg impacts, and 9 out of 36 points (25 percent) for upper leg impacts.⁴⁰ The proposed scoring method is based on the relative frequency of AIS 3+ injuries⁴¹ in the U.S. and the proportion of those pedestrian injuries across body regions.

³⁸ For Euro NCAP, the inverse impact test is used when any lower performance limits are exceeded.

³⁹ <https://www.nhtsa.gov/document/ncap-roadmap>.

⁴⁰ Euro NCAP Assessment Protocol v10.0.3 used a scoring distribution of 24 out of 36 points (66.7 percent) for head impacts, 6 out of 36 points (16.7 percent) for lower leg impacts, and 6 out of 36 points (16.7 percent) for upper leg impacts.

⁴¹ The Abbreviated Injury Scale (AIS) is a 6-point ranking system used for ranking the severity of injuries. AIS 3+ Injuries means injuries of severity level 3 (serious), 4 (severe), 5 (critical), and 6 (fatal) according to the Abbreviate Injury Scale. www.aam.org.

NHTSA requested comment on whether injury severity should be prioritized over injury frequency in this calculation, or whether any other changes should be considered to the proposed $\frac{3}{8}$ th, $\frac{3}{8}$ th, $\frac{2}{8}$ th scoring for head impacts, lower leg impacts, and upper leg impacts, respectively.

b. Test Speeds

The Euro NCAP test procedures are representative of a pedestrian crossing the street and being struck in the side by a vehicle traveling at 40 km/h (25 mph). NHTSA requested comments on whether U.S. NCAP should maintain the 40 km/h test speed to harmonize with Euro NCAP or consider other test speeds based on an analysis of crashes in the U.S. market.

c. Documentation

NHTSA proposed adopting the Euro NCAP crashworthiness pedestrian protection test devices, test procedures, and some (though not all) of the scoring methods. Between the December 2015 notice and the May 2023 RFC, there were several updates to Euro NCAP procedures. In the May 2023 RFC, NHTSA proposed adopting the following test procedures and versions:

- (1) Euro NCAP Pedestrian Testing Protocol, Version 8.5, October 2018.
- (2) Euro NCAP Assessment Protocol—Vulnerable Road User Protection, Part 1—Pedestrian Impact Assessment, Version 10.0.3, June 2020.
- (3) Euro NCAP Pedestrian Headform Point Selection, V2.1, October 2017.
- (4) Euro NCAP Film and Photo Protocol, Chapter 8—Pedestrian Subsystem Tests, V1.3, January 2020.
- (5) Euro NCAP Technical Bulletin TB 008, Windscreen Replacement for Pedestrian Testing, Version 1.0, September 2009.
- (6) Euro NCAP Technical Bulletin TB 019, Headform to Bonnet Leading Edge Tests, Version 1.0, June 2014.
- (7) Euro NCAP Technical Bulletin TB 024, Pedestrian Human Model Certification, V2.0, November 2019.

In the RFC, NHTSA requested comments on whether any changes or other considerations needed to be taken into account before adopting these documents. One notable change between this list of documents and the list of documents NHTSA proposed in 2015 is the replacement of Technical Bulletin (TB) 013 with TB 024 (item 7 above). Both of these documents discuss computer models used to validate active hoods for head-to-hood impact tests. NHTSA requested comment on TB 024 and its relevance to U.S. NCAP.

d. Active Hood Detection and Deployment

One mitigation strategy used to lower risk of pedestrian injury is the use of active hood technology. An active hood system is designed to lift the hood upwards when the vehicle detects an impact with a pedestrian. This action increases the distance between the hood and any rigid components that may be present in the engine bay or front trunk. To allow active hoods to be deployed during pedestrian testing, manufacturers must be able to prove that their active hood systems trigger on leg-to-bumper impact at multiple points along the vehicle's bumper. In its RFC, NHTSA proposed using the full vehicle bumper test zone for active hood detection testing.

To trigger the active hoods during testing, Euro NCAP currently uses the Pedestrian Detection Impactor 2 (PDI–2) legform. However, NHTSA noted that the Informal Working Group for Deployable Pedestrian Protection Systems (IWG–DPPS) was investigating the use of FlexPLI in place of the PDI–2. NHTSA requested comments on whether the PDI–2 legform or the FlexPLI should be used for the active hood detection testing.

2. Comments Received

a. Apportionment of Scoring

There was little support from commenters for NHTSA's proposed scoring apportionment of $\frac{3}{8}$ th, $\frac{3}{8}$ th, $\frac{2}{8}$ th for head, lower leg, and upper leg impacts, respectively. Most commenters, including ACT, Auto Innovators, GM, HATCI, Honda, Humanetics, and IIHS, recommended the Agency place additional emphasis on head impact performance to better reflect injury severity. IIHS referenced multiple studies which have shown that the head is the most commonly injured body region in seriously or fatally injured pedestrians in the U.S., United Kingdom, Germany, and Japan. Autoliv and Consumer Reports concurred with the proposed apportionment but recommended monitoring in case the Agency needs to adjust further, noting the distribution should be based on the risk for Abbreviated Injury Scale (AIS) 3+ injuries. However, HATCI commented that "focusing on AIS 3+ diminishes the large percentage of AIS 4+ and fatal injuries that may be affected by the headform test."

ASC proposed an apportionment that more closely modeled Euro NCAP's, stating: "Like Euro NCAP, ASC proposes that points should emphasize head protection as first priority" Similarly, Rivian recommended a

scoring apportionment to align with Euro NCAP more closely. ASC, Rivian, and public citizens all suggested a scoring apportionment of 50 percent for head impacts. Auto Innovators recommended an apportionment with even greater weighting for the head (61.1 percent). Auto Innovators' recommended apportionment applied the findings of the Department of Transportation's publication on the Value of a Statistical Life to the relative frequency of U.S. pedestrian injuries based on injury severity level.

In January 2023, Euro NCAP increased the percentage of points required to obtain a 5-star VRU safety rating from 60 percent to 70 percent of the maximum. NSC recommended that NHTSA should also increase the minimum passing score from the proposed 21.600 points (60 percent) to 25.200 points (70 percent) to align with the current Euro NCAP 5-star rating for VRU safety.

b. Test Speeds

All of the automakers and many other industry groups who commented, including Auto Innovators, ASC, Consumer Reports, Autoliv, and CASR, agreed that the proposed test impact speed of 40 km/h (25 mph) is reasonable and sufficient for U.S. NCAP. Most commenters emphasized that this speed allows for harmonization with Euro NCAP and other NCAPs globally, where pedestrian fatalities have decreased over time. GM, HATCI, VW, and Auto Innovators also mentioned that the complementary benefits of PAEB provide further justification that the impact test speeds do not need to be increased beyond 40 km/h (25 mph).

Honda noted that current test devices are only proven to be biofidelic up to 40 km/h (25 mph), and IIHS recommended NHTSA complete further research into updated test devices and methods before considering increased test speeds. Humanetics suggested NHTSA should perform additional research to determine how vehicle designs optimized for higher test speeds would perform at lower test speeds for pedestrian protection.

Other commenters, including advocacy groups and individual members of the public, stated that NHTSA should increase the test impact speeds for pedestrian protection. Salud America stated test speeds up to 35 mph (56 km/h) should be considered; an additional 20.2 percent of fatalities occur between 25 and 35 mph. Many advocacy groups and public citizens argued the test speeds should be increased to the highest levels possible. CAS stated the tests "should be

conducted at the highest speeds allowed by the technical limitations of test equipment.” In its comment, NACTO referenced a recent study that found, among other things, more than three quarters of the 60 most dangerous corridors for pedestrians in the U.S. have speed limits of 30 mph or higher.⁴² NACTO stated the test speeds should therefore be increased but did not indicate a suggested target speed.

c. Documentation

Most commenters supported NHTSA’s plan to use the documents and test procedures as outlined in the RFC, which included:

- (1) Euro NCAP Pedestrian Testing Protocol, Version 8.5, October 2018.
- (2) Euro NCAP Assessment Protocol—Vulnerable Road User Protection, Part 1—Pedestrian Impact Assessment, Version 10.0.3, June 2020.
- (3) Euro NCAP Pedestrian Headform Point Selection, V2.1, October 2017.
- (4) Euro NCAP Film and Photo Protocol, Chapter 8—Pedestrian Subsystem Tests, V1.3, January 2020.
- (5) Euro NCAP Technical Bulletin TB 008, Windscreen Replacement for Pedestrian Testing, Version 1.0, September 2009.
- (6) Euro NCAP Technical Bulletin TB 019, Headform to Bonnet Leading Edge Tests, Version 1.0, June 2014.
- (7) Euro NCAP Technical Bulletin TB 024, Pedestrian Human Model Certification, V2.0, November 2019.

Most automakers suggested NHTSA follow the discussions of Euro NCAP and implement any updates to these documents as they are released to maximize harmonization. Specifically, IIHS stated that “it seems illogical to choose an outdated set of protocols to assess future vehicles.” The updated documents that IIHS referenced are the Euro NCAP Pedestrian Testing Protocol and the Euro NCAP Assessment Protocol, which include updates such as the new lower leg impactor (aPLI) and increased WAD limit of 2500 mm. GM provided a specific recommendation concerning TB 019, requesting that it be incorporated into the overall testing procedure instead of remaining a standalone document.

Regarding TB 024, all commenters who responded were in favor of using its models and methods to calculate head impact times when evaluating active hoods. Many commenters also emphasized that doing so would harmonize with Euro NCAP. In VW’s opinion, “[t]he TB 024 method has proven its feasibility over the span of

time it has been in effect in Europe.” Autoliv encouraged NHTSA to follow the next steps being discussed for Euro NCAP updates, including looking at the full body motion of pedestrians. According to Autoliv, “higher velocity of the head at impact and assessing the neck and thorax injuries . . . cannot be assessed with spherical impactor testing.”

d. Active Hood Detection and Deployment

All commenters who provided input on the active hood detection area agreed that the detection area should correspond to the full bumper test width as defined for the lower leg impact tests.

Regarding the option of using the PDI–2 legform or the FlexPLI impactor, Honda, Rivian, Autoliv, and Tesla all agreed that the PDI–2 is the preferred testing device. Rivian specified that the PDI–2 has a lower mass, which allows for better detection of smaller stature adults and children. Auto Innovators stated that the manufacturer should have the option to choose which test device is more representative of the populations it intends to address. Auto Innovators also encouraged NHTSA to “consider the finding of the IWG–DPPS and conduct any additional research necessary to determine whether the PDI–2 is an accurate surrogate for smaller stature pedestrians, or whether there is a need to consider alternate options.” In contrast, VW stated “the FlexPLI would be the better choice of the two options,” but did not provide further justification.

3. Discussion and Agency Decision

a. Apportionment of Scoring

NHTSA has decided to increase the proportion of points for head impacts to align more closely with the Euro NCAP scoring apportionment. NHTSA agrees with commenters’ assertion that more emphasis should be placed on head impacts due to the higher severity of head injuries compared to lower leg and upper leg injuries. Several commenters offered suggestions for various scoring apportionments based on body region, but the general consensus among commenters was to increase the proportion of points for head impacts. As ASC included in their comment: “Like Euro NCAP, ASC proposes that points should emphasize head protection as first priority” However, it should be noted that Euro NCAP recently reduced the points allocated to head impact testing from 24 points (66.7 percent) in the Assessment Protocol—VRU v10.0.3 to 18 points (50 percent) in v11.3. While this revised

value is less than Euro NCAP’s previous apportionment, it remains higher than the apportionment NHTSA proposed in the RFC for head impacts (13.5 points, or 37.5 percent).

A higher proportion of points allocated to head impacts aligns with what the advocacy groups and consumers stated they expect to see from a consumer information program. Additionally, it aligns with requests from automakers by adjusting the apportionment based on injury severity while also bringing the scoring more in line with Euro NCAP.

Therefore, NHTSA has decided to adjust the scoring apportionment as follows: (1) the adult and child head impact test results will contribute 50 percent of the available points for a maximum component score of 18.000 points; (2) the upper leg impact test results will account for 25 percent of the available points for a maximum component score of 9.000 points; and (3) the lower leg impact test results will cover 25 percent of the available points for a maximum component score of 9.000 points (Table 6). This scoring apportionment roughly aligns with the Euro NCAP Assessment Protocol—VRU v11.3 scoring of 18 points for head impacts (50 percent), 9 points for knee/tibia impacts (25 percent), 4.5 points for femur impacts (12.5 percent), and 4.5 points for pelvis impacts (12.5 percent).⁴³

NHTSA has also decided to keep the proposed minimum score to achieve credit as 21.600 out of the available 36.000 points (60 percent). While Euro NCAP recently increased its threshold to 70 percent, it also simultaneously implemented other changes to its program that NHTSA did not propose. For example, Euro NCAP now uses the aPLI impactor in addition to the points allocation changes mentioned earlier. Thus, the two programs are not directly comparable in their current states. Additionally, as detailed in the NCAP roadmap, NHTSA plans to implement a new rating system beginning with MY 2028 vehicles. Pedestrian Protection credit acknowledged via a checkmark is anticipated to last for two model years (MYs 2026 and 2027) as a result of the new rating system. During this limited timeframe, if the minimum passing score is set too high, few vehicles may receive credit in the near term and vehicle manufacturers will not have sufficient time to make adjustments to

⁴³ Since NHTSA will be utilizing the FlexPLI instead of the aPLI, it will not be measuring impact values specifically for the pelvis. The TRL upper legform will be used to account for the same 9 points that Euro NCAP distributes between the femur and pelvis measurements.

⁴² <https://jtlu.org/index.php/jtlu/article/view/1825>.

meet the standard. This could result in the detrimental outcome of consumers losing the ability to successfully differentiate between vehicles as intended by the NCAP program. As such, a minimum score is appropriate at this initial stage of the crashworthiness pedestrian protection testing program. The Agency anticipates revisiting the apportionment of this scoring system as the NCAP VRU rating system develops.

TABLE 6—SCORING APPORTIONMENT SUMMARY

Body region	Apportionment (%)	Maximum possible points
Head	50	18.000
Upper Leg	25	9.000
Lower Leg	25	9.000
Total Points	36.000

b. Test Speeds

Regarding test speeds, NHTSA has decided to use test impact speeds that simulate a pedestrian being struck in the side by a vehicle traveling at 40 km/h (25 mph) as proposed in the RFC. Most automakers supported harmonizing with Euro NCAP and maintaining 40 km/h (25 mph) impact test speeds, while most advocacy groups and the general public supported increasing the test speeds to higher levels. One justification provided by the advocacy groups for testing at higher speeds is that U.S. roads typically have higher speed limits, and people typically drive faster than the posted speed limits. Further, the advocacy groups noted that more fatalities occur at impact speeds greater than 40 km/h (25 mph). NHTSA agrees with the commenters that fatalities do typically occur at higher speeds (70 km/h (43.5 mph) on average), but the practicability of designing a vehicle front end to achieve a high score becomes increasingly difficult as the impact speed increases due to the energy dissipation required. The target impact speed of 40 km/h (25 mph) was selected in part because the majority of pedestrian collisions occur at this speed or less. Further, as NHTSA determined in the December 2015 RFC, test speeds above 40 km/h (25 mph) are not warranted due to the changing dynamics of a pedestrian-vehicle interaction as vehicle speeds increase. More specifically, increased impact speeds result in an increased likelihood of the pedestrian’s head overshooting the vehicle’s hood and windshield. No commenters provided any data or insight into possible solutions to this

inherent problem in terms of testing or scoring.

NHTSA also agrees with the commenters who expressed that the proliferation of PAEB would tend to decrease the impact speed of vehicles with pedestrians.⁴⁴ For vehicles equipped with a PAEB system traveling at speeds above 40 km/h (25 mph), an impact with a pedestrian may still occur as the vehicle slows down to speeds at or below 40 km/h (25 mph) if the PAEB system engages but is unable to fully stop the vehicle. Additionally, NHTSA agrees with commenters that harmonization between U.S. NCAP and other NCAPs globally is beneficial when possible. The Agency will therefore use test impact speeds to simulate a pedestrian being struck in the side by a vehicle traveling at 40 km/h (25 mph).

c. Documentation

NHTSA will maintain and update its own test procedures independently for U.S. NCAP. However, the Agency has decided to adopt the Euro NCAP crashworthiness pedestrian protection test devices and general test procedures as proposed in the RFC as a basis for its own protocols. Some of the documents have been updated to newer versions; NHTSA will use some, but not all, of the updated versions for U.S. NCAP. The documents that NHTSA will use for the crashworthiness pedestrian protection program are listed below.

(1) Euro NCAP Pedestrian Testing Protocol, Version 8.5, October 2018. NHTSA has decided not to use the updated Version 9.1 at this time. As discussed above, NHTSA will use a WAD limit of 2100 mm for U.S. NCAP. Additionally, the Agency will not use the aPLI for leg impact tests but will instead use the FlexPLI for lower leg impact tests.

(2) Euro NCAP Assessment Protocol—Vulnerable Road User Protection, Part 1—Pedestrian Impact Assessment, Version 10.0.3, June 2020. NHTSA has decided not to use the updated Version 11.4 at this time. As explained by the discussion above on the aPLI, NHTSA will use the FlexPLI to evaluate lower leg impacts.

(3) Euro NCAP Pedestrian Headform Point Selection. Due to the differences in scoring systems and data submission, NHTSA will create a similar scoring sheet specific to the crashworthiness pedestrian protection program implemented in U.S. NCAP.

⁴⁴ See NHTSA’s final rule adopting a new Federal Motore Vehicle Safety Standard to require automatic emergency braking (AEB), including pedestrian AEB (PAEB), systems on light vehicle. 89 FR 39696 (May 9, 2024).

(4) Euro NCAP Film and Photo Protocol, Chapter 8—Pedestrian Subsystem Tests, V1.4, July 2023. This is the updated version compared to V1.3, which NHTSA had proposed in the RFC. The updates in V1.4 did not affect Chapter 8, so the procedure is the same as what NHTSA proposed in the RFC. Therefore, NHTSA will use V1.4.

(5) Euro NCAP Technical Bulletin TB 008, Windscreen Replacement for Pedestrian Testing, Version 1.0, September 2009. This is still the current version used by Euro NCAP, so NHTSA will use it as well.

(6) Euro NCAP Technical Bulletin TB 019, Headform to Bonnet Leading Edge Tests, Version 1.0, June 2014. This is still the current version used by Euro NCAP, so NHTSA will use it as well.

(7) Euro NCAP Technical Bulletin TB 024, Pedestrian Human Model Certification, V4.0, January 2024. NHTSA has analyzed the updates for v3.0 and v4.0 of TB 024 and determined the most recent version (v4.0) is acceptable for the U.S. NCAP.

NHTSA will continue to monitor Euro NCAP’s updates to these test procedures. In response to GM’s comment about embedding TB 019 into the Pedestrian Testing Protocol, NHTSA will organize all test protocols and documents into a single package, similar to those published for NCAP’s other crashworthiness tests.

All commenters supported the use of the models and methods in TB 024 to calculate head impact times to evaluate vehicles with active hoods. Using TB 024 harmonizes with Euro NCAP and most commenters agreed these methods and models are currently the most widely accepted in the industry. Therefore, NHTSA has decided to apply the models and methods of TB 024 for evaluating vehicles with active hoods. Additionally, NHTSA analyzed the updates to TB 024 between v2.0, which was current at the time of the RFC, and v4.0, which is the most recent version. The Agency determined that the most recent version, v4.0, is acceptable for U.S. NCAP and will harmonize with Euro NCAP by adopting this version.

d. Active Hood Detection and Deployment

All commenters who provided input on the active hood detection area agreed with NHTSA’s proposal to use the entire vehicle bumper test width as defined for the lower leg impact tests. Thus, the Agency will implement this plan as proposed.

NHTSA has decided to use the PDI–2 for pedestrian detection testing with active hoods. Almost all of the commenters agreed that the PDI–2 is the

preferred impactor for active hood detection. As noted by multiple commenters, there are pros and cons for both the PDI-2 and the FlexPLI when used for active hood detection. The PDI-2 has a lower mass than the FlexPLI, which means it is more difficult for a vehicle to detect contact. It also better represents a child or small stature adult, like Rivian stated in its comment.

NHTSA has followed the findings of the IWG-DPPS regarding research and comparisons between the PDI-2 and FlexPLI for active hood detection. The IWG-DPPS noted that the FlexPLI could represent a pedestrian surrogate that can be used for the sensing verification of a DPPS but can only represent a limited range of typical load cases.⁴⁵ In comparison, the PDI-2 is a more conservative impactor as it represents the hardest to detect (HTD) case for active hood detection. According to a summary table in the IWG-DPPS report, the PDI-2 would be the first choice as a pedestrian representative. However, the report also states that while the PDI-2's "very conservative and demanding requirements seem appropriate for consumer tests, it sometimes underestimates the loads that are emanated from a pedestrian onto a sensing system."⁴⁶ These conservative and demanding requirements make it a good choice as a pedestrian representative for NCAP as they lead to a more stringent test and higher level of safety. Taking this into account with the support from the commenters, NHTSA has decided to use the PDI-2 for active hood detection in its crashworthiness pedestrian protection program. Additionally, use of the PDI-2 for active hood detection harmonizes the U.S. NCAP procedure with Euro NCAP.

NHTSA will deploy an active hood in accordance with manufacturer instructions prior to launching the headform, including the irrevocable selection of the minimum and maximum period of time between device deployment and the impact of the headform to ensure full deployment at impact. Upon request, manufacturers are expected to provide information to NHTSA explaining the basic operational characteristics of their active hood sensor system.

⁴⁵ Oliver Zander et al. 2023. "Development of a Standard for Deployable Pedestrian Protection Systems (DPPS) for Amendments to UN Global Technical Regulation No. 9 and UN Regulation No. 127." Paper Number 23-0144 of 27th ESV conference proceedings. 2023.

⁴⁶ Id.

D. Data Acquisition and Reporting

1. RFC Summary

NHTSA requested comments on data recording and presentation, such as self-reporting of impact test results by vehicle manufacturers, how those test results are used during verification testing, and publication of results. Comments regarding data acquisition and reporting are summarized into four categories: manufacturer-reported data, correction factors during verification testing, publication of results, and optional vehicle features that affect testing and scoring. A brief discussion providing more detail on each of these groups is discussed below.

a. Manufacturer-Reported Data

NHTSA proposed to initially operate its crashworthiness pedestrian protection program in a fully self-reported manner. Vehicle manufacturers would be expected to report all predicted head, upper leg, and lower leg impact test data to NCAP to receive crashworthiness pedestrian protection credit for their vehicles. This methodology aligns with NCAP's current crash avoidance program, in which manufacturers provide data to indicate whether each vehicle model passes various ADAS tests. Unlike Euro NCAP, where manufacturers may assign some head impact points on the hood as "blue points"⁴⁷ where the head impact performance measure is unpredictable, NHTSA's proposal did not permit assigning blue points on the hood and required the manufacturer to self-report with sufficient data that its vehicle meets the NCAP performance criteria to receive crashworthiness pedestrian protection credit. Further, Euro NCAP does not require automakers to submit any data for lower leg and upper leg impacts and only requires the automakers to submit HIC₁₅ or color data for all grid locations, excluding blue points. NHTSA requested comments on what kind and how much data should be collected from manufacturers in the verification process. Primarily, the Agency inquired whether simulated data should be allowed and how this data should be validated.

⁴⁷ Blue points are those where pedestrian protection performance measure is unpredictable, as indicated by the test results provided by the manufacturer. In Euro NCAP, blue grid points are limited to the following structures: plastic scuttle, windscreen wiper arms and windscreen base, headlamp glazing, and break-away structures.

b. Correction Factors During Verification Testing

NHTSA proposed to use the manufacturer's supplied predicted head impact test data in conjunction with the data collected during the Agency's verification testing to calculate the head sub-score, similar to the process used by Euro NCAP. The resulting NCAP data would be compared to the manufacturer's predicted data to determine a correction factor to apply to the entire head impact test data set. NHTSA requested comment on the proposal to adjust submitted head impact test values by a correction factor calculated based on the actual test results.

c. Publication of Results

As the Agency is still considering the best approach to convey vehicle safety information on the Monroney label and developing a new rating system that will include several planned NCAP updates, NHTSA did not propose changes to the Monroney label. NHTSA requested comment on whether a checkmark on the NHTSA.gov website would be adequate for informing consumers of which vehicles achieve the minimum score in the pedestrian protection tests.

d. Optional Vehicle Features That Affect Testing and Scoring

Currently, NHTSA reports vehicle safety ratings on a per-model basis, with separate ratings for different drivetrains due to differences in rollover resistance. For the crash avoidance testing program, vehicles that are equipped with an ADAS technology as standard equipment are noted as such, as are vehicles that have the same technology as optional equipment. For the crashworthiness pedestrian protection program, NHTSA anticipates that trim lines or options that change the ride height of the vehicle, the clearance under the hood, or the shape of the headlights or bumper may have significant effects on the outcome of the crashworthiness pedestrian protection tests. NHTSA requested comment on how credit should be assigned in the event that multiple trim levels and options affect the outcome of the crashworthiness pedestrian protection tests.

2. Comments Received

a. Manufacturer-Reported Data

Vehicle manufacturers largely agreed that simulated test results should be acceptable with varying degrees of NHTSA oversight or physical testing for validation. Most of the commenters that supported simulated data, including

Humanetics, Honda, Rivian, and Autoliv, agreed that some level of physical test validation would also be necessary. Some commenters, such as GM and Auto Innovators, highlighted the fact that allowing automakers to self-report simulated data would provide a cost-effective method to get as much information to consumers as quickly as possible. Auto Innovators suggested the automakers should be able to self-report the results of either physical testing or Computer-Aided Engineering (CAE) modeling. Some commenters, including Hyundai, VW, and CASR, recommended harmonizing with Euro NCAP procedures, which undertake verification testing on all vehicles.

AAA, ACT, and individual members of the public recommended only accepting physical tests. AAA stated that “only physical test results can provide insight into how well a system actually protects pedestrians.”

Most respondents, including AAA, Autoliv, and Auto Innovators, recommended comprehensive test results should be available on an “as needed” basis. Honda recommended using the predicted grid color map from Euro NCAP while HATCI recommended the same, with additional details provided as necessary. CAS recommended requiring that manufacturers submit full test reports, including full data traces, photos, and videos.

b. Correction Factors During Verification Testing

Most commenters, including Autoliv, Honda, and Auto Innovators, agreed with NHTSA’s proposal for adjusting the manufacturer-provided head score by using a correction factor. Honda added that this approach “has also been demonstrated to be successful with other NCAPs.” GM specified its view that hardware data provided by an OEM which follows the “Assessment Protocol” process should be accepted by NHTSA without additional verification. However, GM added that “predicted” data, such as CAE data, could be subject to a verification test.

c. Publication of Results

Most commenters expressed support for adopting a 5-star system with several automakers and auto industry groups, including Auto Innovators, Honda, GM, HATCI, and Consumer Reports, supporting the proposed system as a sufficient temporary measure. Consumer Reports surmised that a comparative rating system would better allow consumers to make informed decisions. A large number of commenters, including Autoliv, NACTO,

WalkMedford, the National Association of Mutual Insurance Companies (NAMIC), ASC, CAS, NSC, National Transportation Safety Board (NTSB), and San Francisco Municipal Transportation Agency (SFMTA), recommended including the ratings on the Monroney label.

d. Optional Vehicle Features That Affect Testing and Scoring

There was not much agreement among commenters on how to account for vehicle options that may affect crashworthiness pedestrian protection. Auto Innovators, Honda, and HATCI recommended clarifying which trim levels were tested since differences in trim levels may result in different performance. Humanetics and ACT recommended optional features be independently assessed. When optional features cannot be independently assessed, AAA recommended assigning credit to the worst-performing model while Autoliv recommended assigning credit to the highest-selling model. CAS and Consumer Reports recommended assigning credit to the worst-case configuration.

3. Discussion and Agency Decision

a. Manufacturer-Reported Data

In the near term, the Agency has decided to move forward with its plan to accept self-reported data from vehicle manufacturers for its crashworthiness pedestrian protection program. NHTSA will accept self-reported data for head, upper leg, and lower leg crashworthiness pedestrian protection tests as initially proposed. This data may be in part derived from CAE/simulation data. As several commenters have mentioned, requiring physical test data for every impact point is overly burdensome for manufacturers. This burden is magnified when considering the various options and trim levels which may affect vehicle performance.

However, as Humanetics, Rivian, IIHS, and others suggested, physical testing of selected test points is necessary to validate CAE results. Thus, it is NHTSA’s expectation that vehicle manufacturers perform some level of physical impact testing on a production-level vehicle before submitting performance data that has been generated via simulation. This methodology aims to avoid imposing infeasible requirements while also maintaining program integrity. The Agency also hopes that these reasonable requirements will encourage manufacturer participation.

NHTSA acknowledges the apprehension voiced by NACTO and

others regarding uncertainty in self-reported data standards. While the use of NHTSA-generated data is ideal, the Agency’s limited resources do not currently allow for testing of all models that could receive credit as meeting NCAP’s criteria. Thus, self-reported data will be accepted to provide as much information to the consumer as possible. NHTSA will thoroughly review all data submitted.

Because of the lack of NHTSA-contracted laboratories currently available, the Agency does not find it practicable at this time to require their use for validation of simulated data. Thus, for this program stage, manufacturer-provided physical test data collected to validate any supplied simulation data may originate from either in-house or third-party test laboratories. It is important to note that all NHTSA-sponsored verification testing will be performed at a NHTSA-contracted laboratory under Agency supervision. NHTSA is considering a plan to require vehicle manufacturers to use NHTSA-contracted laboratories for all impact testing in the future. This requirement is currently enforced for NCAP’s optional testing program; under this provision, vehicle manufacturers fund desired testing, but NHTSA oversees test setup, test conduct, and data quality control.⁴⁸

NHTSA will require predicted head and leg response data values to provide credit for acceptable crashworthiness pedestrian protection performance. Specifically, NHTSA will require actual or predicted HIC₁₅ for each headform grid point, actual or predicted upper legform bending moment and force for each bumper impact location, and actual or predicted lower legform tibia bending moment and MCL and ACL/PCL elongations for each bumper impact location. Manufacturers will submit this information to NHTSA in a standardized format, to be detailed at a later date. This is an additional requirement beyond NHTSA’s original proposal, which only sought to receive predicted score “bands” for each head impact grid point and every upper and lower leg impact location. Although HATCI expressed concerns regarding the confidentiality of internal design processes, the Agency reasons that receiving more specific information will increase the transparency of self-reported data, thereby increasing the Agency’s confidence in the data received. The Agency hopes to alleviate the concerns of those who questioned the validity of self-reported, CAE-generated data. The predicted data

⁴⁸ 52 FR 31691.

received from manufacturers will be treated as confidential and individual self-reported values will not be released to the public, similar to how self-reported data is handled currently for crash avoidance NCAP. NHTSA will convert the data received to predicted score “color bands” and proceed with scoring self-reported data as proposed in the May 2023 RFC.

As noted earlier, vehicle manufacturers must provide evidence that a production-level vehicle has undergone physical impact testing. At this time, NHTSA will not require a specific number of impacts to verify simulated data submitted, but the manufacturer must identify which points received physical testing and which were predicted using a simulation. A test report detailing the findings of the vehicle manufacturer’s validation testing must be generated before submission of the aforementioned predicted test data to the Agency. Additionally, an identifying test report number must accompany the test data received for each vehicle model under consideration for credit. The comprehensive report, along with time-stamped supplementary videos, will be made available to the Agency for review upon submission of data for each vehicle model, if and when it is requested by NHTSA. The Agency may choose to implement more stringent physical impact requirements in the future to verify simulated data if it is deemed necessary.

b. Correction Factors During Verification Testing

NHTSA has decided to move forward with the proposed correction factor method. For the headform tests, NHTSA will perform physical tests at 10 head impact locations. The results of these tests will be compared to the results submitted by the vehicle manufacturers at the corresponding impact locations and a correction factor will be calculated from this comparison. This correction factor will be applied to all manufacturer-submitted head impact results for the vehicle model to calculate new results, which will then be used to determine the vehicle’s final head sub-score.

For the upper and lower legform tests, NHTSA will perform all necessary impact tests to characterize full bumper crashworthiness performance. Principles of symmetry and adjacency will be employed to efficiently cover the full bumper width unless the manufacturer supplies information detailing why this should not be assumed. This NHTSA-generated legform test data will replace the

manufacturer-submitted data in the vehicle’s scoring calculations.

c. Publication of Results

To expedite implementation, NHTSA will continue with the plan to identify vehicle models that meet crashworthiness pedestrian protection testing requirements (achieve 60 percent of all points possible) on the Agency’s website. This is intended to be a temporary system that will be replaced with a more detailed comparative rating system in the future. This comparative rating system will be implemented with the projected updates to the Monroney label as described in the NCAP roadmap.⁴⁹

d. Optional Vehicle Features That Affect Testing and Scoring

As part of its annual vehicle information collection activities, the Agency will request information regarding predicted performance differences between trim lines and any optional features offered.⁵⁰ NHTSA will supply this information to the public when it conveys performance results for each vehicle model. Several commenters supported this approach, including Honda and HATCI. Given the myriad of features and options available on today’s vehicle fleet, it is difficult for the Agency to determine which vehicle trims within a model will perform differently from others. NHTSA considered following Euro NCAP’s protocol, which is to receive data for only the most popular variant and apply this result to all variants within the model. However, this method may not be the most appropriate, as it could grant credit to vehicles that are considerably different in terms of crashworthiness pedestrian protection performance. As the initial crashworthiness pedestrian protection testing program moves forward, NHTSA will review test data to determine whether this is the most appropriate approach to provide information to the public.

E. Other Comments

1. Comments Received

Some topics were discussed by several commenters despite NHTSA’s not specifically requesting comments on them. The two most-discussed topics were (1) 49 CFR part 581, “Bumper Standard” (part 581)⁵¹ requirements

⁴⁹ <https://www.nhtsa.gov/document/ncap-roadmap>.

⁵⁰ NHTSA receives similar information in support of its crashworthiness and crash avoidance programs.

⁵¹ Part 581 establishes requirements for the impact resistance of vehicles in low-speed front and

conflicting with crashworthiness pedestrian protection design, and (2) adoption of the aPLI as opposed to the FlexPLI for the lower leg impact tests.

a. Conflict With Part 581

NHTSA had previously received comments from manufacturers that incorporating lower leg bumper testing based on Euro NCAP would be difficult due to conflicts with the bumper damageability requirements outlined in 49 CFR part 581.

In response to the May 2023 RFC, Honda and HATCI expressed concern about part 581 damageability requirements competing against crashworthiness pedestrian protection designs. Auto Innovators recommended that NHTSA modify part 581 damageability requirements to better accommodate crashworthiness pedestrian protection designs. GM recommended more research into the feasibility of passing both part 581 and crashworthiness pedestrian protection requirements.

b. Adoption of the aPLI

Many commenters encouraged NHTSA to adopt the aPLI, the latest pedestrian crash testing tool representing a 50th percentile male leg. It features a Simplified Upper Body Part (SUBP) that simulates the upper body mass, allowing enhanced kinematics for assessing knee, upper leg, and lower leg injuries. The aPLI was approved for use by Euro NCAP in TB 029 published in July 2023 and many commenters recommended that NHTSA adopt the aPLI for U.S. NCAP to harmonize with Euro NCAP procedures. Commenters also noted that the aPLI can be used in tests where the FlexPLI may experience difficulty, such as on curved bumpers and vehicles with an LBRL greater than 500 mm.

2. Discussion and Agency Decision

a. Part 581 Issues

The Agency stated in the May 2023 RFC that it has examined potential conflicts between the part 581 requirements and pedestrian crashworthiness leg impact testing. NHTSA concluded that vehicles should be able to meet both part 581 requirements and receive a non-zero score in the Euro NCAP lower legform tests. As discussed in the May 2023 RFC, NHTSA has tested vehicles that meet the part 581 damageability requirements and receive non-zero

rear collisions. The purpose of this standard is to reduce physical damage to the front and rear ends of a passenger motor vehicle from low-speed collisions.

scores on FlexPLI legform testing. The example provided in the RFC was a 2016 hatchback passenger car that NHTSA tested, which obtained a result of 4.41 out of 6.00 points (73.5 percent) for lower leg impact testing. As such, NHTSA does not believe the new pedestrian protection program will contradict the part 581 damageability requirements.

b. Adoption of the aPLI

While NHTSA concurs with commenters regarding the use of the latest testing tools, the Agency has not yet thoroughly evaluated the aPLI. Thus, NHTSA will adopt the FlexPLI as a temporary solution while it conducts the required analysis for the aPLI. The FlexPLI has historically been used in Euro NCAP testing and is adequately biofidelic. Given the urgent need for crashworthiness pedestrian protection testing, NHTSA’s immediate adoption of the FlexPLI in NCAP testing will prompt more rapid improvement in pedestrian protection than waiting to adopt the aPLI.⁵² Additionally, NHTSA anticipates that manufacturers and test facilities are familiar with the FlexPLI, which will smooth the adoption process.

VI. Procedure in Detail

A. Differences From Euro NCAP Tests and Assessment Protocols

As previously stated, NHTSA will use the Euro NCAP testing protocol as a basis from which to conduct its assessment on all selected vehicles, including pickup trucks and large SUVs. For the most part, the procedures of Euro NCAP Testing Protocol v8.5 are applicable to all vehicles eligible for

testing under U.S. NCAP (vehicles with a gross vehicle weight rating less than or equal to 4,536 kg, or 10,000 lb.). However, some adjustments to the Euro NCAP testing protocol are needed to align with the self-reporting aspect of U.S. NCAP, to better reflect pedestrian protection provided by the vehicle’s front end, and to improve test practices. These noteworthy changes are outlined in the following subsections.

1. Use of FlexPLI

While Euro NCAP has replaced the FlexPLI with the aPLI for its lower leg impact tests in its most recent testing protocol (v9.1), NHTSA will use the FlexPLI for U.S. NCAP testing while it completes further analysis on the aPLI. As discussed previously, the Agency will perform its own testing, research, and evaluations prior to making a decision to adopt the aPLI. To prevent a delay of the crashworthiness pedestrian protection program, NHTSA will use the FlexPLI for lower leg impacts.

At the time of the May 2023 RFC, Euro NCAP was using its VRU Testing Protocol v8.5, which specified that manufacturers could choose whether to use the FlexPLI or the TRL upper legform for vehicles with an LBRL greater than or equal to 425 mm and less than or equal to 500 mm. Euro NCAP has since updated its VRU Testing Protocol to v9.1, which no longer allows manufacturers this option due to the adoption of the aPLI. NHTSA will not allow manufacturers the option to choose the TRL upper legform for vehicles with an LBRL greater than or equal to 425 mm and less than or equal to 500 mm. Instead, the FlexPLI will be

used for all vehicles with an LBRL less than or equal to 500 mm.

2. No FlexPLI Bumper Testing When LBRL Is Greater Than 500 mm

For vehicles that have an LBRL value of greater than 500 mm, NHTSA will assign a “default red, no points” score to the particular point under assessment (e.g., some bumper points may be above 500 mm and not tested while others may be equal to or below 500 mm and tested). The FlexPLI has a poor kinematic response when used to impact bumpers with an LBRL greater than 500 mm. Additionally, NHTSA is not aware of any existing countermeasures that would improve the lower leg safety of vehicles with an LBRL greater than 500 mm when tested with the FlexPLI.

3. FlexPLI Qualification Procedure and Testing

As mentioned previously, differences exist between NHTSA’s adopted FlexPLI qualification procedure/schedule and those of other entities. UNECE R127 specifies two dynamic qualification tests—a pendulum test and an inverse impact test, in addition to a series of quasi-static tests. In UNECE R127, the dynamic qualification tests are performed before and throughout a test series, while the quasi-static tests are performed on an annual basis. Euro NCAP only specifies the dynamic inverse impact test and the quasi-static tests. As shown in Table 7 below, NHTSA prescribes the inverse impact test after every 20 impacts, the quasi-static tests once per year, and only requires the pendulum test if any lower performance limits are exceeded.

TABLE 7—FLEXPLI QUALIFICATION TESTING SCHEDULE

Test mode	Frequency	Align with Euro NCAP?
Inverse Impact Test	After every 20 impacts	Yes.
Quasi-static Tests	Every 12 months	Yes.
Pendulum Test	If testing exceeds any lower performance limits	No.

4. Bumper Corner Definition

In the Euro NCAP test protocol, the width of the lower legform test area is defined by the point of contact of a 60-degree plane and the forward-most point on the vehicle front-end. This method is referred to as the “60-degree angle method.” Alternatively, the UNECE R127 and GTR 9 regulations use the “corner gauge method.” This

method identifies the corner of the bumper by locating the outermost point of contact of the gauge when it is moved parallel to a vertical plane with an angle of 60 degrees to the vertical longitudinal center plane of the vehicle. Both methods additionally specify that the outer limits of the bumper test zone are either defined by the bumper corners using the 60-degree angle/corner gauge

method or the outermost ends of the bumper beam, whichever is larger.

As described in detail previously, NHTSA will use the corner gauge method instead of the 60-degree angle method for NCAP testing. NHTSA will also include the stipulation that if the bumper beam width differs from the width defined by the corners using the corner gauge method, the larger of the areas will be used.

⁵² As indicated in NHTSA’s NCAP roadmap (<https://www.nhtsa.gov/document/ncap-roadmap>),

the Agency plans to use the aPLI for NCAP starting with MY 2030 vehicles.

5. Active Hood Detection

For vehicles with active hoods, the Agency will require manufacturers to demonstrate that their system activates when there is a leg-to-bumper impact both at the vehicle centerline and as far outboard as the outboard end of the bumper test zone. This is the same requirement as in the Euro NCAP test procedure. However, NHTSA will use the corner gauge method discussed above when determining the outboard end of the bumper test zone. Like Euro NCAP, NHTSA will also use the PDI-2 impactor for the purpose of deploying the active hood.

6. WAD Limit

When marking up the vehicle to be tested, Euro NCAP currently specifies that the WADs should be marked at 100 mm intervals from 1000 mm to at least 2500 mm. This 2500 mm limit was an increase from 2100 mm when Euro NCAP introduced the VRU Test Protocol v9.0.3 in May 2023, replacing the Pedestrian Test Protocol v8.5. As explained in detail previously, NHTSA will use the WAD limit of 2100 mm for its NCAP crashworthiness pedestrian protection program, but it will consider increasing the limit to 2500 mm in the future.

7. Self-Reporting System

In Euro NCAP, manufacturers typically self-report predicted head impact test data of their vehicles before Euro NCAP conducts its impact testing on those vehicles. However, upper leg and lower leg impact test data are not provided by the manufacturer. Instead, these data are gathered from the testing conducted by the Euro NCAP test facilities. U.S. NCAP will operate its

program in a fully self-reported manner, with verification testing performed on a selection of vehicles to ensure accuracy—similar to the Agency’s crash avoidance test program.⁵³ Vehicle manufacturers will report all head, upper leg, and lower leg impact test data to NCAP to receive crashworthiness pedestrian protection credit for their vehicles. As mentioned earlier, NHTSA will accept simulated data, but it must be validated by physical testing on a production-level vehicle.

Specifically, NHTSA will require actual or predicted HIC₁₅ for each headform grid point, actual or predicted upper legform bending moment and force for each bumper impact location, and actual or predicted lower legform tibia bending moment and MCL and ACL/PCL elongations for each bumper impact location. Manufacturers will submit this information to NHTSA in a NHTSA-specified standardized format and will include a unique test report number identifying the vehicle model’s results. This test report, along with time-stamped supplementary videos, will be made available to the Agency for review upon submission of data for each vehicle model upon NHTSA’s request.

NHTSA will not allow the inclusion of “blue points,” which are allowed by Euro NCAP. Due to the unpredictable nature of these grid points, the manufacturer does not include blue points in computing the overall score for the head impact testing assessment submitted to Euro NCAP. Euro NCAP always tests the identified blue points (in addition to selecting grid points) and includes the head impact assessment at these blue points in computing the overall head impact score. For U.S. NCAP, for a manufacturer to self-report

that its vehicle meets the NCAP performance criteria and receives crashworthiness pedestrian protection credit, the manufacturer must have sufficient data to support a predicted point/color value for every head grid point and every upper and lower leg impact test point.

8. NCAP Scoring Apportionment

Euro NCAP recently revised the apportionment of points for scoring the leg and head impacts. Out of a possible 36.0 points, 18.0 points are allocated to head injury data, 9.0 points for lower leg injury data, 4.5 points for upper leg injury data, and 4.5 points for pelvis injury data. NHTSA proposed in the RFC a scoring apportionment that aligned with the relative frequency of AIS 3+ injuries to the body regions in the U.S. Out of a possible 36.0 points, 13.5 were allocated to head impacts, 13.5 points for lower leg impacts, and 9.0 points for upper leg impacts. As previously mentioned in the Comments and Discussion and Agency Decision sections, NHTSA has decided to adjust the scoring apportionment to provide more emphasis on head impacts, which are more likely to be fatal than leg injuries, while still maintaining the value of the legform tests. This adjustment will also help align with Euro NCAP’s current scoring apportionment. The apportionment for U.S. NCAP is as follows: out of a possible 36.000 points, 18.000 points are allocated to head impacts, 9.000 points are allocated for lower leg impacts, and 9.000 points are allocated for upper leg impacts. A comparison of each scoring method is shown below in Table 8.

TABLE 8—SCORING APPORTIONMENT METHODS

Body region	Points apportionment (out of 36.0 possible points)			
	Euro NCAP (2018)	U.S. NCAP RFC (2023)	Euro NCAP (2023)	U.S. NCAP (2024)
Head	24.0 pts (66.67%)	13.5 pts (37.5%)	18.0 pts (50%)	18.000 pts (50%).
Pelvis	4.5 pts (12.5%).
Upper Leg	6.0 pts (16.67%)	9.0 pts (25%)	4.5 pts (12.5%)	9.000 pts (25%).
Lower Leg	6.0 pts (16.67%)	13.5 pts (37.5%)	9.0 pts (25%)	9.000 pts (25%).

9. Credit Publication Process

In Euro NCAP, the vehicle’s VRU sub-score is included in the vehicle’s overall safety rating. At this time, NHTSA will not integrate the crashworthiness pedestrian protection score into its

existing comparative rating system. To expedite implementation of this program, NHTSA will identify vehicle models that meet the crashworthiness pedestrian protection testing requirements (earning at least 21.600

out of 36.000 possible points, or 60 percent) on NHTSA’s website.

B. Injury Limits and Scoring Process

The injury limits and scoring process for NHTSA’s crashworthiness pedestrian protection impact tests will

⁵³ NHTSA is in the process of renewing its existing approved information collection (OMB-

2127-0629) to include collecting self-reported data from the vehicle manufacturers for this new

crashworthiness pedestrian protection testing program.

be largely the same as those in Euro NCAP, as outlined in the Euro NCAP Assessment Protocol—VRU Protection, Part 1—Pedestrian Impact Assessment, Version 10.0.3, June 2020. For U.S. NCAP, each group of component tests (*i.e.*, headform tests, upper legform tests, lower leg tests) will first be scored individually; these component scores will then be summed to determine a crashworthiness pedestrian protection score for each vehicle. The exact number of impact points will vary depending on the geometry of a vehicle. For instance, there may be 200 head impact points on the hood, windshield,

and A-pillars; 15 upper leg impact points on the forward edge of the vehicle’s front-end; and 15 lower leg impact points on the vehicle’s bumper area. Each impact point for each test device will be scored between 0 and 1 point depending on the resulting injury values from the impact test. Each group of component tests (headform tests, upper leg tests, and lower leg tests) will generate its own sub-score as described below. The sum of each of the three sub-scores will result in the final pedestrian protection score, as defined in the following formula: Pedestrian Protection

Score = Head SubScore + Upper Leg SubScore + FlexPLI SubScore.

1. Headform Tests

Each of the head impact locations on a vehicle will contribute equally to the component level sub-score for the head tests. Each impact location will receive a score between 0 and 1 based on the HIC₁₅ value output from the headform impact test. Different ranges of HIC₁₅ values will correspond to different colors and point values based on the Euro NCAP assessment protocol, summarized in Table 9.

TABLE 9—HEADFORM SCORING

Color	HIC minimum	HIC maximum	Points
Green	<650	1.000
Yellow	650	<1,000	0.750
Orange	1,000	<1,350	0.500
Brown	1,350	<1,700	0.250
Red	1,700	0.000

The head impact sub-score will be calculated according to the following formula: Head SubScore = Apportionment of Head Impacts * (Sum of All Head Impact Points)/(Total Number of Head Impact Points).

2. Upper Legform Tests

Each of the upper legform impact locations will contribute equally to the component level sub-score for the upper legform impacts. Each impact location can receive up to 1.00 point on a linear sliding scale between the upper and lower injury limits. This is different

from the headform scoring method, where injury values will be put in discrete scoring bands. The worst-performing injury metric (one of three moments—upper, middle, or lower; or sum of forces) will be used to determine the score using the criteria shown in Table 10.

TABLE 10—UPPER LEGFORM SCORING

Component	Minimum injury	Maximum injury	Maximum points
Bending Moment (Nm)	285	350	1.000
Sum of Forces (N)	5000	6000	

The upper legform scoring is shown graphically in Figure 9 and Figure 10.

Injury values closer to the minimum injury values earn more points and

injury values closer to the maximum injury values earn fewer points.

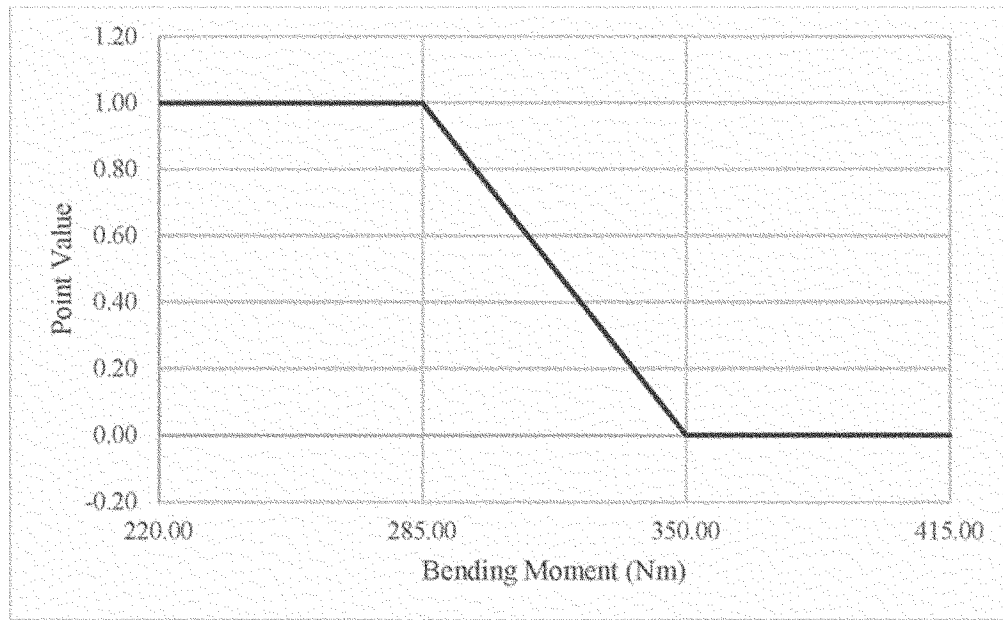

Figure 9: Upper Legform Bending Moment Scoring

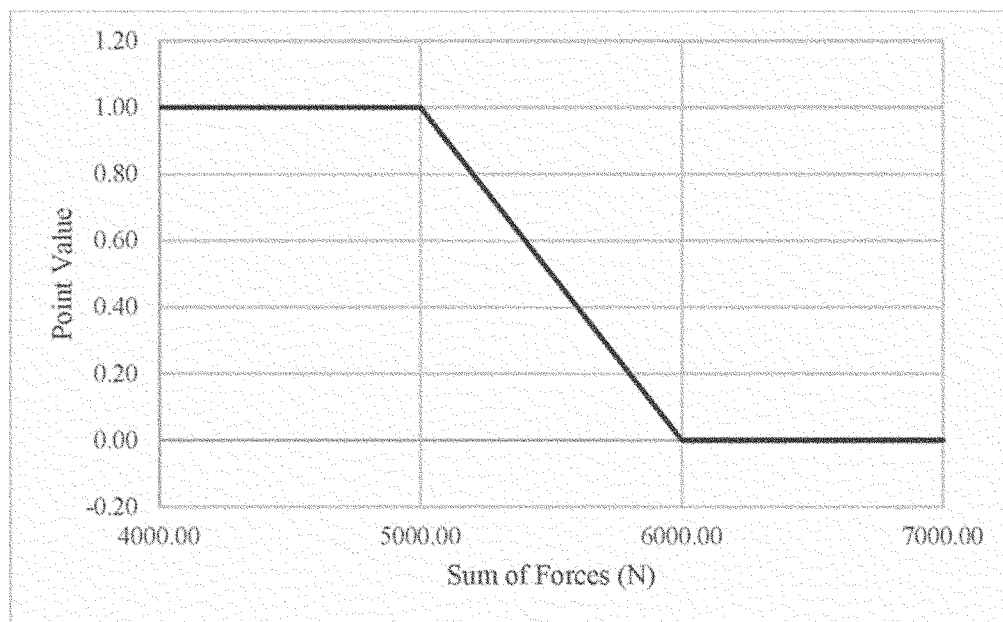

Figure 10: Upper Legform Sum of Forces Scoring

The upper legform impact sub-score will be calculated according to the following formula: Upper Leg SubScore = Apportionment of Upper Leg Impacts * (Sum of All Upper Leg Impact Points) / (Total Number of Upper Leg Impact Points).

3. Lower Legform Tests

Similarly, each of the FlexPLI impact locations on a vehicle will contribute equally to the component level sub-score for the lower legform tests. Each impact location can receive up to 0.500 points from the tibia moments and up to 0.500 points from the ligament elongations, as shown in Table 11. The

tibia score will be determined from the worst of the four tibia measurements—T1, T2, T3, or T4. The ligament elongation will be scored from the MCL as long as neither the ACL nor PCL exceeds the 10 mm elongation limit. If either the ACL or PCL exceed this limit, the overall ligament elongation score will be 0.00.

TABLE 11—FLEXPLI SCORING

Component	Minimum injury	Maximum injury	Maximum points
Tibia Bending (Nm)	282	340	0.500
MCL Elongation (mm)	19	22	0.500
ACL/PCL Elongation (mm)		10	

Similar to the upper legform scoring, the Euro NCAP assessment protocol awards points based on a linear sliding scale between the upper and lower

injury limits using the criteria in Figure 11 and Figure 12. NHTSA will be using this same linear sliding scale for the U.S. NCAP. Again, this is different from

the headform scoring method, where injury values will be put in discrete scoring bands.

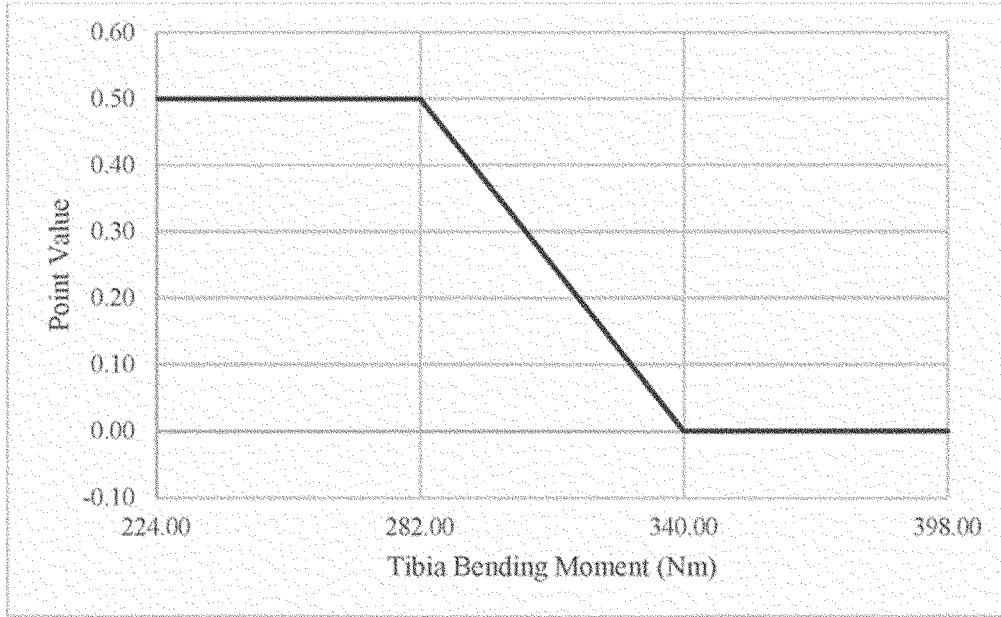

Figure 11: FlexPLI Tibia Bending Moment Scoring

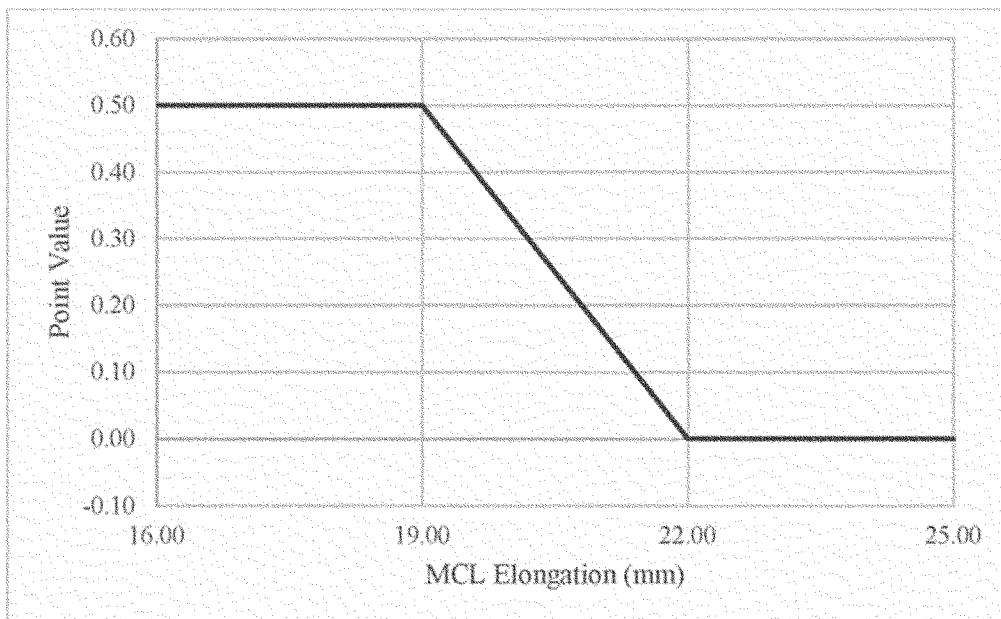

Figure 12: FlexPLI MCL Elongation Scoring

The FlexPLI impact sub-score will be calculated according to the following formula: FlexPLI SubScore = $\frac{\text{Apportionment of FlexPLI Impacts} * (\text{Sum of All FlexPLI Impact Points})}{(\text{Total Number of FlexPLI Impact Points})}$.

C. NCAP Proposal for Awarding Credit

As stated earlier in this notice, NHTSA is implementing the crashworthiness pedestrian protection testing program initially by assigning credit to vehicles that meet NCAP performance test requirements. Initially, instead of rating a vehicle’s crashworthiness pedestrian protection on a scale of 1 to 5 stars, NHTSA will assign credit to vehicles that meet a certain minimum scoring threshold for crashworthiness pedestrian protection. Consumers will be able to compare crashworthiness pedestrian protection by identifying vehicles that NHTSA has designated as meeting this minimum level of pedestrian safety. Furthermore, this approach not only allows early adopters to participate in the program, but it also provides sufficient time for manufacturers to redesign their vehicles to improve pedestrian crashworthiness safety.

For a vehicle to be recognized by NHTSA as meeting the performance requirements for crashworthiness

pedestrian protection, it must score at least 21.600 out of 36.000 points (or 60 percent) combined for the head, upper leg, and lower leg impact tests when tested and scored in accordance with the standards outlined in the previous sections of this notice and the modified apportionment scoring.

As NHTSA is still developing a new rating system that will include several planned NCAP updates, NHTSA is not implementing changes to the Monroney label or overall vehicle rating system at this time. Therefore, NHTSA will inform consumers of vehicles that receive crashworthiness pedestrian protection credit through its website, <http://www.NHTSA.gov>. This approach is similar to the current crash avoidance testing program in NCAP. Currently, ADAS technologies are identified through the use of checkmarks on the Agency’s website.

D. NCAP Verification Testing

NHTSA will implement a verification testing process for the crashworthiness pedestrian protection that is similar to the crash avoidance testing program in NCAP. As mentioned previously in this notice, the manufacturer will be required to submit actual or predicted data for every head impact grid point and every upper and lower leg impact test location. NHTSA will review this information for accuracy and completeness and award credit if the submitted data meet the minimum

criteria outlined previously. For each new model year, NHTSA selects and acquires vehicles for testing under NCAP. Consistent with the processes used in the crash avoidance testing program, NHTSA will select and acquire new model year vehicles for verification testing of their crashworthiness pedestrian protection performance. NHTSA will only select vehicles with test data submitted by the manufacturers and approved by the Agency as meeting the minimum performance criteria for crashworthiness pedestrian protection.

For the upper leg and FlexPLI impact testing, NHTSA will conduct its own tests and use this data instead of the manufacturer’s provided data for the sub-scores. For the head impact testing, NHTSA will select 10 impact locations and conduct its own tests, using this data to calculate a correction factor. NHTSA’s head impact data will be compared to the manufacturer’s provided data at the corresponding impact locations. Consistent with Euro NCAP’s test procedure, each color band will have a 10 percent tolerance when comparing NHTSA’s color band/test values to the manufacturer’s color band/test values (Table 12). For example, if a manufacturer submits a grid point HIC₁₅ falling in the yellow color band but NHTSA’s verification test finds HIC₁₅ to be 1,200, NHTSA will instead classify this grid point as orange.

TABLE 12—ACCEPTABLE HIC RANGE FOR VERIFICATION TESTING

Predicted color band	HIC ₁₅ range	Acceptable HIC ₁₅ range
Green	HIC ₁₅ <650	HIC ₁₅ <722.22
Yellow	650 ≤ HIC ₁₅ <1,000	590.91 ≤ HIC ₁₅ <1,111.11
Orange	1,000 ≤ HIC ₁₅ <1,350	909.09 ≤ HIC ₁₅ <1,500
Brown	1,350 ≤ HIC ₁₅ <1,700	1,227.27 ≤ HIC ₁₅ <1,888.89
Red	1,700 ≤ HIC ₁₅	1,545.45 ≤ HIC ₁₅

The correction factor is then calculated per the following equation: Correction Factor = $\frac{\text{Sum of Actual Test Scores}}{\text{Sum of Predicted Test Scores}}$.

This correction factor is then applied to the manufacturer’s provided data to calculate the corrected head impact sub-score per the following equation: Corrected Head SubScore = $(\text{Head SubScore} - \text{Default Green} - \text{Default Red}) * \text{Correction Factor} + \text{Default Green} + \text{Default Red}$.

A detailed example of the head impact verification test scoring is provided in Appendix C.

VII. Conclusion

NHTSA will implement the crashworthiness pedestrian protection

test devices, test procedures, and scoring methods as discussed above beginning with model year 2026 vehicles. For that model year, NHTSA will assess crashworthiness pedestrian protection for vehicles by calculating a score based on head, upper leg, and lower leg impact data voluntarily submitted by manufacturers. The procedures and scoring methods are based on the Euro NCAP documents listed below.

- (1) Euro NCAP Pedestrian Testing Protocol, Version 8.5, October 2018.
- (2) Euro NCAP Assessment Protocol—Vulnerable Road User Protection, Part 1—Pedestrian Impact Assessment, Version 10.0.3, June 2020.

- (3) Euro NCAP Pedestrian Headform Point Selection, V2.1, October 2017. Note: Due to the differences in scoring systems and data submission, NHTSA will create a similar scoring sheet specific to the crashworthiness pedestrian protection program implemented in U.S. NCAP.
- (4) Euro NCAP Film and Photo Protocol, Chapter 8—Pedestrian Subsystem Tests, V1.4, July 2023.
- (5) Euro NCAP Technical Bulletin TB 008, Windscreen Replacement for Pedestrian Testing, Version 1.0, September 2009.
- (6) Euro NCAP Technical Bulletin TB 019, Headform to Bonnet Leading Edge Tests, Version 1.0, June 2014.

(7) Euro NCAP Technical Bulletin TB 024, Pedestrian Human Model Certification, V4.0, January 2024.

NHTSA will identify new model year vehicles that meet a minimum safety threshold of crashworthiness pedestrian protection on the Agency's website. This minimum safety threshold is a total score of 21.600/36.000 points (60 percent) or greater, where a maximum of 18.000/36.000 points (50 percent) are possible for head impacts, 9.000/36.000 points (25 percent) are possible for lower leg impacts, and 9.000/36.000 points (25 percent) are possible for upper leg impacts. The impact tests simulate a 6-year-old child and an average-size adult male being struck in the side by a vehicle traveling at 40 km/h (25 mph). The area of assessment for the vehicle is limited to all points forward of the WAD2100 mm line. At this time, NHTSA is allowing vehicle manufacturers to self-report their test results for these impact tests to provide this information to consumers as soon as possible. Manufacturer-submitted data will be randomly verified by NHTSA through impact testing performed on select models. These changes will fulfill the mandate set forth in the BIL to amend NCAP to provide the public with important safety information regarding the protection of VRUs.

VIII. Economic Analysis

The changes to NCAP in this final decision notice would ultimately enable a rating system that improves consumer awareness of crashworthiness pedestrian protection systems and the improvements to safety that stem from those systems. These changes may also encourage manufacturers to accelerate the adoption of these systems. The accelerated adoption of pedestrian protection systems would drive any economic and societal impacts that result from these changes and are thus the focus of this discussion of economic analysis. Hence, the Agency has considered the potential economic effects of the inclusion of pedestrian protection systems in NCAP and the potential benefit of eventually developing a new rating system that would include this information.

Crashworthiness pedestrian protection systems are unique because the safety improvements are attributable to improved VRU protection, as opposed to improvements in protection for vehicle occupants that the other crashworthiness components in NCAP provide. Their effectiveness is the reduction of VRU injury and prevention of VRU fatalities when a crash between

a motor vehicle and pedestrian occurs. This effectiveness is typically measured by using a combination of real-world statistical data, laboratory testing, and Agency expertise.

Crashes between pedestrians and motor vehicles present significant safety issues, and NHTSA is particularly concerned about the steady rise in pedestrian fatalities over the last several years. The data from countries that prioritize crashworthiness pedestrian protection systems, via both regulation and other consumer information programs, indicate that these systems are effective in reducing pedestrian injuries and fatalities. BAST in Germany found a correlation between Euro NCAP pedestrian protection scores and pedestrian injuries and fatalities.⁵⁴ The Swedish Transport Administration also found that vehicles that score better in the Euro NCAP pedestrian crashworthiness tests tended to reduce injury in actual crashes.⁵⁵ Although these studies have been limited to certain geographic areas, which may not represent the entire U.S. fleet, they do illustrate how these systems can provide safety benefits. Thus, although the Agency does not have sufficient data to determine the monetized safety impacts resulting from these systems in a way similar to that frequently done for mandated technologies, when compared to the future without this update to NCAP, NHTSA expects that these changes would likely have substantial positive safety effects by promoting earlier and more widespread deployment of crashworthiness pedestrian protection systems.

NCAP also helps address the issue of asymmetric information (*i.e.*, when one party in a transaction is in possession of more information than the other), which can be considered a market failure. Regarding consumer information, the introduction of a potential new component to the NCAP rating system is anticipated to provide consumers additional vehicle safety information regarding the safety of VRUs. This information will help them make more informed purchasing decisions by presenting the relative safety benefits of systems designed to protect not only vehicle occupants but also persons outside the vehicle. While NHTSA

⁵⁴ Pastor, C., "Correlation between pedestrian injury severity in real-life crashes and Euro NCAP pedestrian test results," The 23rd International Technical Conference on the Enhanced Safety of Vehicles, Paper No. 13-0308, 2013.

⁵⁵ Standroth, J. et al. (2014), "Correlation between Euro NCAP pedestrian test results and injury severity in injury crashes with pedestrians and bicyclists in Sweden," *Stapp Car Crash Journal*, Vol. 58 (November 2014), pp. 213–231.

knows that consumers value information about the protection of vehicle occupants when making purchasing decisions, the Agency believes that most consumers are also interested in protecting people who share their roads. Hence, there is a real if unquantifiable value to consumers and to society as a whole for the Agency to provide accurate and comparable vehicle safety information about protecting all lives. At this time, the Agency does not have sufficient data, such as unit cost and information on how soon the full adoption of pedestrian protection systems would be reached, to predict the net increase in cost to consumers with a high degree of certainty.

IX. Appendices

Appendix A: Questions From RFC

[1] NHTSA seeks comment on the topic of female leg safety. Are there data showing that vehicle front end designs that perform well in the FlexPLI and upper legform impact tests would not afford protection to female pedestrians? Are there any legforms representing female or small stature pedestrians? Are there female specific data and associated 5th percentile female specific injury criteria for use with a 5th percentile female legform impactor?

[2] NHTSA seeks comment on what an acceptable humidity tolerance should be for the qualification tests of the upper legform impactor and the associated vehicle test with the upper legform.

[3] NHTSA is requesting comment on the FlexPLI qualification procedures—specifically which procedures (dynamic and quasi-static) should be used for qualification, and how often they should be conducted?

[4] An Agency study of Abbreviated Injury Scale (AIS) 3+ pedestrian injuries in the U.S. showed that the apportionment of points in NCAP for crashworthiness pedestrian protection should be 3/8th for head impact test results (37.5 percent), 3/8th for lower leg impact test results (37.5 percent), and 2/8th for upper leg impact test (25 percent). NHTSA seeks comment on whether injury severity or frequency would be this the most appropriate basis for point allocation apportionment.

[5] As concluded in the Agency's FlexPLI research report, NHTSA believes the FlexPLI legform is biofidelic and seeks comment from the public on whether biofidelity concerns with the FlexPLI still remain at this time.

[6] NHTSA is seeking comment on what procedure it should use for

marking the test zone on bumpers. In other words, should the procedure harmonize with the Euro NCAP 60-degree angle method or should it follow the GTR 9 and UNECE R127 corner gauge method?

[7] GM suggested that if a vehicle has an exposed bumper, the bumper test zone should use the 60-degree angle method instead of testing the full bumper width to eliminate testing at the extreme edge of what may be a curved bumper. NHTSA requests comment on this concern as well, as it is similar to the previous question for bumper test zones.

[8] Given the pedestrian death and injury crisis on U.S. roadways NHTSA is seeking comment on test speeds. Should test speeds for either of the head or leg tests be increased in an attempt to provide better protection to pedestrians in vehicle to pedestrian crashes? Should the area of assessment be increased beyond the WAD limit of 2100 mm currently proposed to account for pedestrian heads overshooting the hood and impacting the windshield or the roof of the vehicle?

[9] NHTSA requests comment on the seven Euro NCAP documents proposed in section IV. F. (Euro NCAP Pedestrian Testing Protocol Version 8.5, Euro NCAP Assessment Protocol—Vulnerable Road User Protection Part 1—Pedestrian Impact Assessment Version 10.0.3, Euro NCAP Pedestrian Headform Point Selection V2.1, Euro NCAP Film and Photo Protocol Chapter 8—Pedestrian Subsystem Tests V1.3, Euro NCAP Technical Bulletin TB 008 Windscreen Replacement for Pedestrian Testing Version 1.0, Euro NCAP Technical Bulletin TB 019 Headform to Bonnet Leading Edge Tests Version 1.0, and Euro NCAP Technical Bulletin TB 024 Pedestrian Human Model Certification

V2.0)—do any elements of these documents need modification for the U.S. NCAP?

[10] NHTSA requests comment on TB 024 and its relevance to the U.S. NCAP. Should the models and methods in TB 024 or some other method be used to calculate head impact times to evaluate vehicles with active hoods?

[11] NHTSA seeks comment on what level of detail should be required for self-reported data. Should manufacturers be allowed to submit predicted head and leg response data, or only actual physical test results? Should reporting consist of just the results for each test location, or should full data traces or a comprehensive test report including photographs and videos be required?

[12] NHTSA requests comment on whether vehicles with an LBRL greater than 500 mm should be eligible to receive crashworthiness pedestrian protection credit because they will automatically receive a zero score for the FlexPLI bumper tests.

[13] NHTSA requests comment on the proposal to reposition the upper legform ±50 mm from the WAD775 target when artificial interference is present or to conduct multiple impacts within ±50 mm from the WAD775 target and use the worst-case result when artificial interference is present.

[14] NHTSA tentatively plans to use the corner gauge and bumper beam width procedure for corner definition for this NCAP proposal and requests comment on this change.

[15] NHTSA seeks comments on whether there is benefit in requiring both the Pendulum and Inverse Impact dynamic qualification tests in addition to the quasi-static tests. Also, what should the qualification test schedule be for the FlexPLI be?

[16] NHTSA seeks comment on what the required detection area should be for vehicles with active hoods. Additionally, which device should be used for assuring the system activates properly, the Flex-PLI or the PDI2?

[17] NHTSA proposes utilizing a modified 3/8, 3/8, 2/8 scoring apportionment for the head impacts, Flex PLI impacts, and upper leg impacts respectively for NCAP and requests comment on this proposal.

[18] NHTSA seeks comment on whether [a checkmark on NHTSA.gov] is an appropriate way to identify vehicles that meet the Agency’s minimum criteria for crashworthiness pedestrian protection, or if some other notation or identifying means is more appropriate.

[19] NHTSA seeks comment on what options or features might exist within the same vehicle model that would affect the vehicle’s performance of crashworthiness pedestrian protection. NHTSA also seeks comment on whether the Agency should assign credit to vehicles based on the worst-performing configuration for a specific vehicle model, or if vehicle models with optional equipment that affect the crashworthiness pedestrian protection credit should be noted as such.

[20] NHTSA seeks comment on the proposal to conduct verification testing as part of the crashworthiness pedestrian protection program by adjusting the head score using a conversion factor determined from laboratory tests and replacing manufacturer supplied FlexPLI and upper leg scores with NHTSA scores from laboratory tests.

Appendix B: Supplementary Tables

TABLE B1—SUMMARY OF DIFFERENCES BETWEEN EURO NCAP ASSESSMENT PROTOCOLS AND U.S. NCAP PROCEDURES

Subject	Euro NCAP ⁵⁶	U.S. NCAP
Vehicle with LBRL between 425 mm and 500 mm (inclusive).	Manufacturer can choose to use either FlexPLI or TRL Upper Legform for the bumper test.	Only FlexPLI will be used for the legform to bumper test.
Vehicle with LBRL >500 mm Bumper Corner Definition	TRL Upper Legform is used instead of FlexPLI 60-degree angle method is used to define bumper corners.	Default red, no points for FlexPLI sub-score. Corner gauge method is used to define bumper corners.
Blue Points for Head Impact Locations.	Allowed	Not allowed, manufacturers must submit predicted or tested head impact results for all points.
FlexPLI Qualification Tests and Schedule.	Inverse test: After every 20 impacts (maximum) and once every 12 months, or if legform exceeds lower performance limits Quasi-static tests: Once per year.	Inverse test: After every 20 impacts Quasi-static tests: Once per year Pendulum test: If testing exceeds any lower performance limits.
Point Apportionment	24/36 pts (66.67%) for head 6/36 pts (16.67%) for upper leg 6/36 pts (16.67%) for lower leg	18,000/36,000 pts (50%) for head. 9,000/36,000 pts (25%) for upper leg. 9,000/36,000 pts (25%) for lower leg.

⁵⁶ The Euro NCAP protocols and version used for this comparison are the Pedestrian Test Protocol v8.5 and the Assessment Protocol—VRU v10.0.3.

TABLE B1—SUMMARY OF DIFFERENCES BETWEEN EURO NCAP ASSESSMENT PROTOCOLS AND U.S. NCAP PROCEDURES—Continued

Subject	Euro NCAP ⁵⁶	U.S. NCAP
Results Reporting	Euro NCAP Five-Star Rating System	Checkmark (or similar) on NHTSA website.

Appendix C: Vehicle Scoring and Verification Testing Example—Passenger Car

In the hypothetical example of a verification test, the vehicle is assumed to have met NHTSA’s minimum requirements for pedestrian protection credit and verification testing; the manufacturer reported to NHTSA that its vehicle met the minimum requirements (i.e., at least 60 percent or 21.600 out of 36.000 points); the manufacturer provided predicted and/or actual test data in a standardized format; NHTSA reviewed this data for accuracy

and completeness; and NHTSA selected this vehicle for verification testing.

Figure C1 and Table C1 are examples of the level of detail of head impact data a manufacturer would provide to NHTSA to receive credit for meeting NHTSA’s pedestrian protection criteria under NCAP.⁵⁷ Figure C1 shows the grid points along the various WAD lines eligible for testing based on vehicle geometry and the manufacturer’s actual or predicted HIC₁₅ for each location. Each grid point also contains an indication of whether the data provided is simulated data or physical test data. Points that were physically tested by the

manufacturer are designated as a circled cell. Points with predicted head impact scores are not circled. Similar to the Euro NCAP test procedures, some points are considered “default red” and “default green” based on their location on the vehicle.⁵⁸ The rest of the eligible grid points are filled with actual or predicted HIC data from the manufacturer. Table C1 shows the tabulated data from Figure C1 and the manufacturer’s predicted score (81.000 out of a possible 136.000) for the head. Figure C1 also denotes with an “X” which grid points were chosen for verification testing by NHTSA.

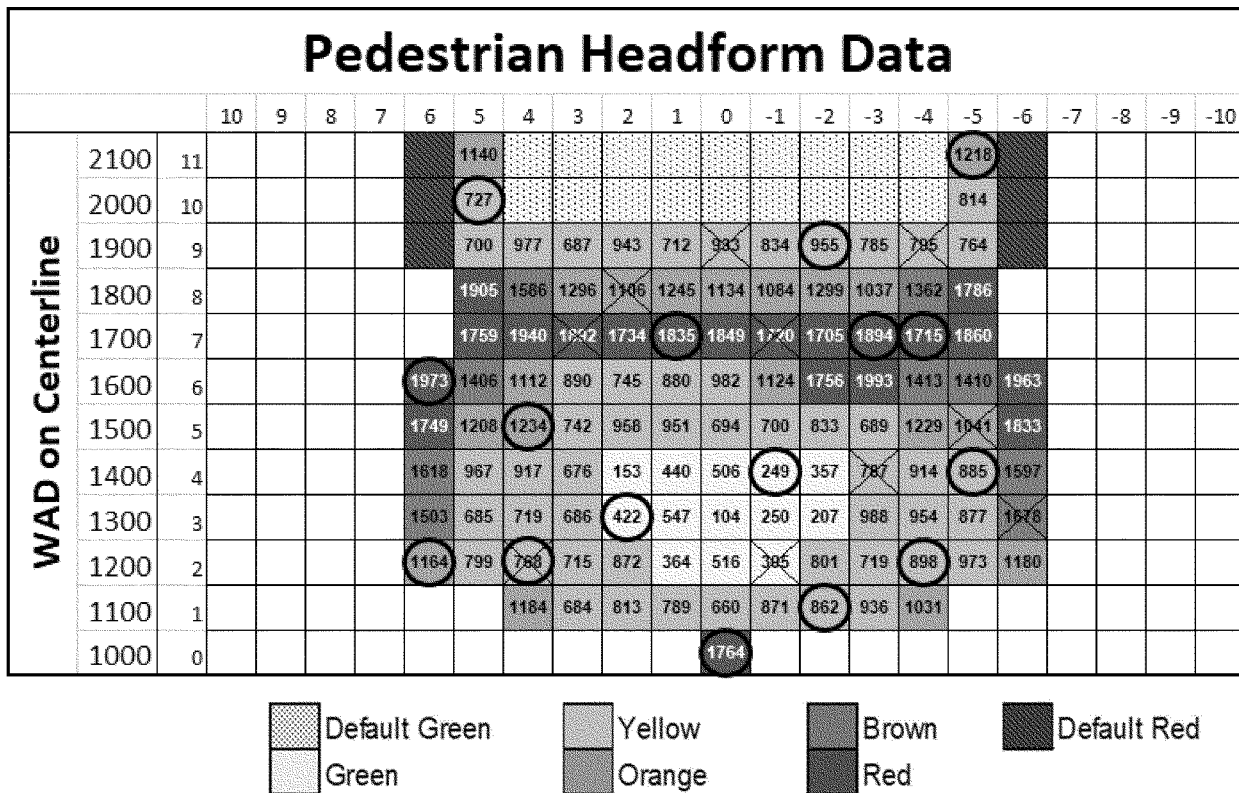

⁵⁷Note that the figures below are examples only; the requested submission format may change.

⁵⁸Euro NCAP stipulates that test points located on the A-pillars are default red, and test points located in the central portion of the windshield

glazing away from edges or underlying components are default green.

Figure C1: Example of Manufacturer's Predicted Head Impact Data

TABLE C1—EXAMPLE OF SCORING OF MANUFACTURER'S PREDICTED HEAD IMPACT DATA

Manufacturer prediction	HIC min.	HIC max.	Point value	Number points	Predicted score
Default Green	n/a	n/a	1.000	18	18.000
Green		<650	1.000	13	13.000
Yellow	650	<1,000	0.750	51	38.250
Orange	1,000	<1,350	0.500	19	9.500
Brown	1,350	<1,700	0.250	9	2.250
Red	1,700		0.000	20	0.000
Default Red	n/a	n/a	0.000	6	0.000
Sum of all points excluding default points to be used for correction factor				112	63.000
Predicted headform score				136	81.000

Table C2 includes both the manufacturer's actual or predicted data for each grid point undergoing testing as well as NHTSA's verification test result in the form of the HIC₁₅ and resulting scoring band. In this example, 7 of the 10 test points resulted in the same scoring band as the prediction, 2 test points resulted in a lower scoring band than the prediction, and 1 test point resulted in a higher scoring band than the prediction. One test location of particular interest in this example is test

location (4, -3). The resulting HIC₁₅ at this test location was 1,046.87, outside the boundaries for the predicted yellow color band, but still within the acceptable HIC₁₅ range for verification testing as described in Table 12. The manufacturer predicted that the 10 test points under consideration would contribute a score of 5.250—as shown in Table C2. However, verification testing determined that these 10 test points scored 4.500 instead of 5.250. Thus, the difference between the manufacturer's

predicted values and those tested resulted in a correction factor of 0.857 (three significant digits) based on the correction factor equation: Correction Factor = (Sum of Actual Test Scores) / (Sum of Predicted Test Scores). Table C2 below shows the actual test scores and predicted scores used for the calculation.

Table C2—Example of Verification Testing Results and Correction Factor

VERIFICATION TESTING			
Test Point Location	Manufacturer Prediction	Test Value (HIC)	Tested Score
9, -4	0.75	1445.14	0.250
2, 4	0.75	821.91	0.750
2, -1	1.00	612.55	1.000
9, 0	0.75	829.58	0.750
4, -3	0.75	1046.87	0.750
7, -1	0.00	3974.53	0.000
8, 2	0.50	925.06	0.500
5, -5	0.50	2030.53	0.000
3, -6	0.25	1202.70	0.500
7, 3	0.00	4810.86	0.000
Total	5.250		4.500
Correction factor		0.857	



	Green		Orange		Red
	Yellow		Brown		

Table C3 calculates the resulting Final Pedestrian Headform Score for this hypothetical vehicle. The correction factor determined above is applied to all grid points that are not default green

grid points. Thus, instead of those points contributing a predicted score of 63.000 points, they only contribute a score of 53.991 points. The 18 default green points still contribute a score of

18.000 (shown in Table C1 and Table C3), giving the vehicle a score of 71.991, or, when scaled for the scoring allocation, a score of 9.528 out of 18.000 points.

Table C3. Example of Headform Score with Correction Factor Applied

112	Predicted (excluding Default Green)	63.000 x 0.857 = 53.991	
6	Default Red	0.000	
18	Default Green	18.000	
136	Total Grid Points	Vehicle Score	71.991
Maximum Pedestrian Headform Score (As shown in Table 6 or 50% allocation of 36.000 points)			18.000
FINAL PEDESTRIAN HEADFORM SCORE			71.991 / 136 * 18.000 = 9.528

For the upper legform score, Table C5 below shows the upper legform verification testing results of the hypothetical vehicle. Note that the manufacturer will have submitted upper, center, and lower bending moments and upper and lower forces for each required impact location along the bumper (also accounting for symmetry and adjacency). These results indicate that the vehicle has achieved the minimum crashworthiness pedestrian protection score of 60 percent (21.600 out of 36.000 total points). Similar to the data provided for the headform impacts, the manufacturer will have provided information showing which locations received physical testing and which locations did not. However, unlike those for the headform impacts, NHTSA's

verification results for the upper legform will replace those provided by the manufacturer.

Due to vehicle geometry, a total of 13 points were eligible for testing, and it was decided that testing would be at test location U 0. Additional tests were conducted at locations U +2, U -4, and U -6. Using symmetry and adjacency, all 13 test locations received scores.

Test locations were scored according to Table C4, as illustrated below. Test location U 0 received a score of 0.000 because all the bending moments and the sum of forces exceeded the maximum injury limits. Test location U +2 also received a score of 0.000. Although some of the bending moments (upper and lower) were below the maximum injury limit, the upper

legform test uses the worst performing injury metric for the test location's score. Both the center bending moment and the sum of forces exceeded the maximum injury limit. Thus, this test location received a score of 0.000. Had test location U +2 been scored based on the upper bending moment, it would have received a score of 0.475; and similarly, had it been scored based on the lower bending moment, it would have received a score of 0.356. Injury values above the minimum injury but below the maximum injury are scored on a sliding scale between 0.000 and 1.000 points for the upper legform. On the other hand, test locations U -4 and U -6 each received scores of 1.000 because all injury criteria were below the minimum injury limit.

TABLE C4—UPPER LEGFORM SCORING

Component	Min. injury	Max. injury	Max. point value
Bending Moment (Nm)	285	350	1.000
Sum of forces (N)	5000	6000	

Using symmetry, test location U -2 receives a score of 0.000 because that is what test location U +2 received. Test locations U +4 and U +6 receive scores of 1.000 because of tests conducted at U -4 and U -6. Using adjacency, test locations U +1, U -1, U +3, and U -3 all receive scores of 0.000 because they are adjacent to a test location that received a score of 0.000. Likewise, test

locations U +5 and U -5 each receive a score of 1.000, being adjacent to two locations each scoring 1.000. In some cases, a manufacturer may provide data explaining why its vehicle should not be subject to symmetry or adjacency.

Table C6 shows the scoring for the hypothetical upper legform test. Overall, the vehicle received a score of 6.000 out

of a possible 13.000 for the upper legform test. When scaled for the 25 percent points allocation (9.000 out of 36.000 points), the upper legform can receive a maximum score of 9.000 points. This testing results in a final upper legform score of 4.154 out of 9.000 points.

BILLING CODE 4910-59-P

Table C5. Example of Upper Legform Test Results

Pedestrian Upper Legform	Bending Moment (Nm)						Forces (kN)			Total Points	
	Upper		Center		Lower		Upper	Lower	Sum		
	Value	Points	Value	Points	Value	Points	Value	Value	Points		
1st Point to Test: U 0											1.000
U +6 Symmetry											1.000
U +5 Adjacent											1.000
U +4 Symmetry											1.000
U +3 Adjacent											0.000
U +2 Tested	319.15	0.475	374.28	0.000	326.87	0.356	2.83	2.86	5.66	0.340	0.000
U +1 Adjacent											0.000
U 0 Tested	376.95	0.000	459.15	0.000	417.88	0.000	3.01	3.48	6.49	0.000	0.000
U -1 Adjacent											0.000
U -2 Symmetry											0.000
U -3 Adjacent											0.000
U -4 Tested	147.83	1.000	160.73	1.000	147.22	1.000	1.86	3.25	4.82	1.000	1.000
U -5 Adjacent											1.000
U -6 Tested	165.33	1.000	200.61	1.000	186.05	1.000	1.51	2.58	4.09	1.000	1.000



TABLE C6—EXAMPLE OF UPPER LEGFORM SCORE

Test Location	U+6	U+5	U+4	U+3	U+2	U+1	U0	U-1	U-2	U-3	U-4	U-5	U-6
Points	1.000	1.000	1.000	0.000	0.000	0.000	0.000	0.000	0.000	0.000	1.000	1.000	1.000
Total Number of Test Points													
13													
Total Vehicle Score													
6.000													
Maximum Pedestrian Upper Legform Score													
9.000													
(9 of 36 points - shown in Table 5)													
FINAL PEDESTRIAN UPPER LEGFORM SCORE													
(6.000 / 13) * 9.000 = 4.154													



BILLING CODE 4910-59-C

Finally, Table C8 below shows the lower legform FlexPLI verification

testing results of the hypothetical vehicle. Detailed data, to include the four tibia bending moments and ACL,

MCL, and PCL elongations, has been received to show that this vehicle meets the 60 percent (21.600 out of 36.000

total points) pedestrian protection requirement. The lower legform data gathered by NHTSA will replace the data provided by the manufacturer. For this vehicle, all points along the LBRL are less than 500 mm, so all test locations are tested. If there were portions of the LBRL that were greater than 500 mm, those locations would not be tested and would be given a “default red, no points” score. Like the upper legform WAD775 tests, this vehicle’s geometry requires 13 locations to be

scored for the bumper testing. In this test series, testing began at location L +1 and additional tests were carried out at locations L -3 and L -5.

Test locations were scored according to Table C7 as illustrated below. Testing conducted at location L +1 yielded a score of 0.932 (0.500 + 0.432). The tibia bending moments were all below the minimum injury limit, awarding full points for that component. The MCL elongation fell between the minimum injury limit and maximum injury limit,

awarding partial points. For FlexPLI injury values above the minimum injury threshold and below the maximum injury threshold, points are awarded between 0.000 and 0.500 on a linear sliding scale. Neither the ACL nor PCL exceeded the limit. Thus, this test location received a score of 0.932. Tests conducted at locations L -3 and L -5 yielded full points as none of the values exceeded the minimum injury limits, nor were the ACL nor PCL limits exceeded.

TABLE C7—FLEXPLI SCORING

Component	Min. injury	Max. injury	Max. point value
Tibia bending (Nm)	282	340	0.500
MCL elongation (mm)	19	22	0.500
ACL/PCL elongation (mm)	10

Using the same symmetry concepts discussed above, test locations L -1, L +3, and L +5 inherited the scores from the opposite side. Using adjacency, test locations L 0, L +2, and L -2 each inherited a score of 0.932 because that was the lowest score of the two adjacent

test locations. Test locations L +4, L -4, L +6, and L -6 each inherited a perfect score of 1.000 because both adjacent test locations had scores of 1.000.

The resulting lower legform score for this vehicle is shown below in Table C9 and was 12.660 out of a maximum

13.000, or 8.765 out of a maximum 9 when using the 50 percent, 25 percent, 25 percent scoring allocation.

BILLING CODE 4910-59-P

TABLE C8—EXAMPLE OF LOWER LEGFORM TEST RESULTS

Pedestrian Lower Legform	Tibia Bending Moment (Nm)				ACL/PCL (mm)		MCL Elongation (mm)		Total Points
	T1	T2	T3	T4	ACL PCL Value	PASS/ FAIL	Value	Points	
	Value								
1st Point to Test: L +1									
L +6									1.000
L +5									1.000
L +4									1.000
L +3									1.000
L +2									0.932
L +1	210.37	168.77	127.35	68.42	5.66	5.38	19.41	0.432	0.932
L 0									0.932
L -1									0.932
L -2									0.932
L -3	166.44	153.62	153.23	77.63	4.39	2.97	12.22	0.500	1.000
L -4									1.000
L -5	114.34	137.06	113.75	65.64	2.78	5.56	10.47	0.500	1.000
L -6									1.000

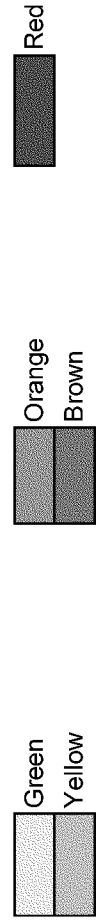

TABLE C9—EXAMPLE OF LOWER LEGFORM SCORE

Test Location	L+6	L+5	L+4	L+3	L+2	L+1	L+0	L-1	L-2	L-3	L-4	L-5	L-6
Points	1.000	1.000	1.000	0.932	0.932	0.932	0.932	0.932	0.932	1.000	1.000	1.000	1.000
Total Number of Test Points	13												
Total Vehicle Score	12.660												
Maximum Pedestrian Upper Legform Score	9.000												
FINAL PEDESTRIAN UPPER LEGFORM SCORE	(12.660 / 13) * 9.000 = 8.765												



In Table C10 below, the scores from the three component tests are summed

and compared to the maximum available score. In this scenario, the

hypothetical vehicle had reduced component level scores in each of the three categories, but still maintained a

total score above 21.600 (60 percent). Therefore, this vehicle would continue

to receive pedestrian protection credit on <http://www.NHTSA.gov>.

TABLE C10—EXAMPLE OF OVERALL PEDESTRIAN PROTECTION SCORE

	Actual score	Maximum score	Percentage
Headform Test	9.528	18.000	52.9%
Upper Legform Test	4.154	9.000	46.2%
Lower Legform Test	8.765	9.000	97.4%
Total	22.447	36.000	62.3%
Received Pedestrian Protection Credit?			Yes

Issued in Washington, DC, under authority delegated in 49 CFR 1.95 and 501.

Adam Raviv,
Chief Counsel.

[FR Doc. 2024–27446 Filed 11–22–24; 8:45 am]

BILLING CODE 4910–59–P

DEPARTMENT OF THE TREASURY

Office of Foreign Assets Control

Notice of OFAC Sanctions Actions

AGENCY: Office of Foreign Assets Control, Treasury.

ACTION: Notice.

SUMMARY: The U.S. Department of the Treasury’s Office of Foreign Assets Control (OFAC) is publishing the names of one or more persons that have been placed on OFAC’s Specially Designated Nationals and Blocked Persons List (SDN List) based on OFAC’s determination that one or more applicable legal criteria were satisfied. All property and interests in property subject to U.S. jurisdiction of these persons are blocked, and U.S. persons are generally prohibited from engaging in transactions with them. Additionally, OFAC is publishing updates to the identifying information of one or more persons currently included on the SDN List.

DATES: This action takes effect on the date listed in **SUPPLEMENTARY INFORMATION**.

FOR FURTHER INFORMATION CONTACT: OFAC: Bradley T. Smith, Director, tel.: 202–622–2490; Associate Director for Global Targeting, tel.: 202–622–2420; Assistant Director for Licensing, tel.: 202–622–2480; Assistant Director for Regulatory Affairs, tel.: 202–622–4855; or the Assistant Director for Compliance, tel.: 202–622–2490.

SUPPLEMENTARY INFORMATION:

Electronic Availability

The Specially Designated Nationals and Blocked Persons List and additional

information concerning OFAC sanctions programs are available on OFAC’s website. (<https://www.treasury.gov/ofac>).

Notice of OFAC Actions

A. On July 25, 2024, OFAC determined that the property and interests in property subject to U.S. jurisdiction of the following persons are blocked under the relevant sanctions authority listed below.

Individuals

1. LOPEZ AMBROSIO, Whiskey Hans, Guatemala; DOB 03 Nov 1999; POB Malacatan, Guatemala; nationality Guatemala; citizen Guatemala; Gender Male (individual) [TCO] (Linked To: LOPEZ HUMAN SMUGGLING ORGANIZATION).

Designated pursuant to section 1(a)(ii)(C) of Executive Order 13581 of July 24, 2011, “Blocking Property of Transnational Criminal Organizations,” 76 FR 44757 (July 27, 2011), as amended by Executive Order 13863 of March 15, 2019, “Taking Additional Steps to Address the National Emergency With Respect to Significant Transnational Criminal Organizations,” 84 FR 10255 (March 19, 2019) (E.O. 13581, as amended), for being owned or controlled by, or having acted or purported to act for or on behalf of, directly or indirectly, the LOPEZ HUMAN SMUGGLING ORGANIZATION, a person whose property and interests in property are blocked pursuant to E.O. 13581, as amended.

2. LOPEZ ESCOBAR, Ronaldo Galindo (a.k.a. “Tio Roni”), San Francisco Nueva Reforma, Malacatan, Guatemala; DOB 14 Sep 1977; POB Guatemala; nationality Guatemala; citizen Guatemala; Gender Male; Passport 000510054 (Guatemala) (individual) [TCO] (Linked To: LOPEZ HUMAN SMUGGLING ORGANIZATION).

Designated pursuant to section 1(a)(ii)(C) of E.O. 13581, as amended, for being owned or controlled by, or having acted or purported to act for or on behalf of, directly or indirectly, the LOPEZ HUMAN SMUGGLING ORGANIZATION, a person whose property and interests in property are blocked pursuant to E.O. 13581, as amended.

3. HERNANDEZ VANEGAS, Karen Stefany, Guatemala; DOB 12 Mar 2002; POB Livingston Izabal, Guatemala; nationality Guatemala; citizen Guatemala; Gender Female (individual) [TCO] (Linked To:

LOPEZ HUMAN SMUGGLING ORGANIZATION).

Designated pursuant to section 1(a)(ii)(C) of E.O. 13581, as amended, for being owned or controlled by, or having acted or purported to act for or on behalf of, directly or indirectly, the LOPEZ HUMAN SMUGGLING ORGANIZATION, a person whose property and interests in property are blocked pursuant to E.O. 13581, as amended.

Entity

1. LOPEZ HUMAN SMUGGLING ORGANIZATION, Mexico; Guatemala; Target Type Criminal Organization [TCO].

Designated pursuant to section 1(a)(ii)(A) of E.O. 13581, as amended, for being a foreign person that constitutes a significant transnational criminal organization.

Dated: July 25, 2024.

Lisa M. Palluconi,

Deputy Director, Office of Foreign Assets Control, U.S. Department of the Treasury.

Editorial Note: This document was received for publication by the Office of the Federal Register on November 19, 2024.

[FR Doc. 2024–27462 Filed 11–22–24; 8:45 am]

BILLING CODE 4810–AL–P

DEPARTMENT OF THE TREASURY

Internal Revenue Service

Publication of the Tier 2 Tax Rates

AGENCY: Internal Revenue Service (IRS), Treasury.

ACTION: Notice.

SUMMARY: Publication of the tier 2 tax rates for calendar year 2025 as required by section 3241(d) of the Internal Revenue Code. Tier 2 taxes on railroad employees, employers, and employee representatives are one source of funding for benefits under the Railroad Retirement Act.

DATES: The tier 2 tax rates for calendar year 2025 apply to compensation paid in calendar year 2025.

FOR FURTHER INFORMATION CONTACT: Kathleen Edmondson, CC:EEE:EOET:ET1, Internal Revenue