

**DEPARTMENT OF TRANSPORTATION****National Highway Traffic Safety Administration****49 CFR Part 571**

[Docket No. NHTSA–NHTSA–2024–0057]

RIN 2127–AK98

**Federal Motor Vehicle Safety Standards; Pedestrian Head Protection, Global Technical Regulation No. 9; Incorporation by Reference**

**AGENCY:** National Highway Traffic Safety Administration (NHTSA), Department of Transportation (DOT).

**ACTION:** Notice of proposed rulemaking (NPRM).

**SUMMARY:** NHTSA proposes a new Federal Motor Vehicle Safety Standard (FMVSS) that would ensure passenger vehicles with a gross vehicle weight rating (GVWR) of 4,536 kilograms (kg) (10,000 pounds (lb)) or less are designed to mitigate the risk of serious to fatal injury in child and adult pedestrian crashes. The proposed standard would establish test procedures simulating a head-to-hood impact and performance requirements to minimize the risk of head injury. This NPRM is based on a Global Technical Regulation (GTR) on pedestrian protection, with focused enhancements to address safety problems and a regulatory framework unique to the United States.

**DATES:** Comments must be received on or before November 18, 2024.

*Proposed compliance date:* The first September 1, two (2) years following the date of publication of any final rule in the **Federal Register**, with optional early compliance permitted. Final-stage manufacturers and alterers would be provided an additional year to comply.

**ADDRESSES:** You may submit comments to the docket number identified in the heading of this document by any of the following methods:

- *Federal eRulemaking Portal:* Go to <https://www.regulations.gov>. Follow the online instructions for submitting comments.

- *Mail:* Docket Management Facility, M–30, U.S. Department of Transportation, West Building, Ground Floor, Rm. W12–140, 1200 New Jersey Avenue SE, Washington, DC 20590.

- *Hand Delivery or Courier:* West Building, Ground Floor, Room W12–140, 1200 New Jersey Avenue SE, between 9 a.m. and 5 p.m. Eastern Time, Monday through Friday, except Federal holidays. To be sure someone is there to

help you, please call (202) 366–9332 before coming.

Regardless of how you submit your comments, please mention the docket number of this document.

*Instructions:* For detailed instructions on submitting comments and additional information on the rulemaking process, see the Public Participation heading of the **SUPPLEMENTARY INFORMATION** section of this document. Note that all comments received will be posted without change to <https://www.regulations.gov>, including any personal information provided.

*Docket:* For access to the docket to read background documents or comments received, go to [www.regulations.gov](https://www.regulations.gov), or the street address listed above. To be sure someone is there to help you, please call (202) 366–9322 before coming. Follow the online instructions for accessing the dockets.

**FOR FURTHER INFORMATION CONTACT:** For non-legal issues: Vincent Wu, Office of Crashworthiness Standards (telephone: (202) 366–1740, fax (202) 493–2990). For legal issues: Matthew Filpi, Office of the Chief Counsel (telephone: 202–366–3179). The mailing address for these officials is: National Highway Traffic Safety Administration, 1200 New Jersey Avenue SE, Washington, DC 20590.

**SUPPLEMENTARY INFORMATION:****Table of Contents**

- I. Executive Summary
  - A. This Proposed Standard
  - B. Potential Impacts of the Rulemaking
- II. Safety Need
- III. Foundations of the Proposal
- IV. The Global Technical Regulation
  - A. Introduction
  - B. GTR 9
  - C. Further Observations About the Differences Between This NPRM and the GTR
- V. Approach of the Proposed Standard
  - A. Overview
  - B. Relevance to the Involved Vehicles
  - C. Advantages of Headform Component Tests
  - D. Head Injury Criterion (HIC)
  - E. Speed and Angle at Which the Headforms Would Impact the Hood
- VI. Defining the Relevant Areas Subject to the Standard
  - A. Determining the Hood Top
  - B. Hood Area
  - C. Defining the Child Headform Test Area and the Adult Headform Test Area
- VII. Proposed Requirements and Assessing Compliance
  - A. Amount of Hood Area That Must Conform to HIC 1000
  - B. Manufacturer Designations of HIC1700 Areas
  - C. First Point of Contact
  - D. Consideration Related to the Amount of Test Area That Must Meet the HIC100 and HIC1700 Limits

- E. Considerations for Expansion of Test Area When It Is Less Than Two Thirds of the Numerical Value of the Hood Area
- VIII. GTR 9 Terminology and Amendment 3
  - A. Comparison of Terminology
  - B. Amendment 3
- IX. Headform Characteristics
  - A. General
  - B. Qualification Limits
  - C. Repeatability and Reproducibility
- X. Other Issues
  - A. Active Hoods
- XI. Effect on Other Standards
- XII. Proposed Lead Time
- XIII. Benefits and Costs
- XIV. Considered Alternatives
- XV. Rulemaking Analyses and Notices
- XVI. Public Participation

**I. Executive Summary**

Improving pedestrian safety is a high priority of the Department of Transportation. Data show pedestrian fatalities increasing substantially in recent years. NHTSA issues this NPRM in an effort to address this safety problem. This NPRM proposes a new Federal Motor Vehicle Safety Standard (FMVSS) that would ensure that passenger vehicles are designed to reduce the risk of serious to fatal child and adult head injury in pedestrian crashes. This rulemaking initiates the process of adopting a Global Technical Regulation (GTR) on pedestrian protection as an FMVSS, with focused enhancements to the GTR to address safety problems and a regulatory framework unique to the U.S. In addition, this NPRM furthers the goals and policies of DOT's January 2022 National Roadway Safety Strategy, which describes the five key objectives of the Department's Safe System Approach: safer people, safer roads, safer vehicles, safer speeds, and post-crash care.

New Federal Motor Vehicle Safety Standard No. 228, *Pedestrian head protection*, would apply to passenger cars, light trucks (including pickups), multipurpose passenger vehicles (MPVs) (MPVs include sport utility vehicles (SUVs), crossover vehicles and vans) and buses with a GVWR of 4,536 kg (10,000 lb) or less. The standard would require vehicles to meet a head injury criterion (HIC) when subjected to testing simulating a head-to-hood impact. The vehicles would have to reduce the risk of serious to fatal head injury to child and adult pedestrians in impacts at vehicle speeds up to 40 km/h (25 mph), which encompass about 70 percent of pedestrian injuries from vehicle impacts. Moreover, it is expected the standard would be beneficial even at higher speeds.<sup>1</sup> This

<sup>1</sup> Hu, J., Lin, Y.-S., Boyle, K., Bonifas, A., Reed, M.P., Gupta, V., & Lin, C.H. (2023, November).

NPRM advances NHTSA's objective of adopting a motor vehicle crashworthiness safety standard to ensure that passenger vehicles are designed to mitigate the risk of serious to fatal child and adult pedestrian head injury.

This NPRM is part of a multi-step approach to enhance vehicle performance against pedestrian injury. First, it initiates the process of adopting Global Technical Regulation No. 9 (GTR 9), "Pedestrian safety," into the Federal safety standards. NHTSA has collaborated with governments internationally to develop GTR 9, and numerous countries have adopted the GTR into their regulations. FMVSS No. 228 would establish a pedestrian standard domestically, to ensure that all vehicles with a GVWR of 4,536 kg (10,000 lb.) or less manufactured in or imported into the United States—including a sub-group of light trucks (large pickups and large SUVs) more common in the U.S. than in other parts of the world—mitigate the risk of serious head injury to pedestrians.

Second, the standard would provide a regulatory counterpart to NHTSA's planned crashworthiness pedestrian protection testing program in the New Car Assessment Program (NCAP) in the near term.<sup>2</sup> On May 26, 2023, NHTSA published an NCAP Request for Comment (NCAP RFC) proposing to adopt a crashworthiness pedestrian protection program into NHTSA's NCAP.<sup>3</sup> NCAP would build on proposed FMVSS No. 228 and incorporate enhanced crashworthiness tests into NCAP that go beyond the specifications of proposed FMVSS No. 228. NCAP remains a consumer information program that provides consumers with vehicle safety information for their purchasing decisions. Providing this information encourages manufacturers to voluntarily make changes to vehicles that reflect positively in the NCAP safety information and thereby improves safety through the marketplace. FMVSSs, on the other hand, are mandatory and mandate at least a minimum level of safety that all new vehicles *must* provide to every purchaser. NHTSA has observed that, in

the case of both electronic stability control and rear visibility cameras, only approximately 70 percent of vehicles had these technologies during the time they were part of NCAP. Thus, while NCAP serves a vital safety purpose, NHTSA also recognizes its limitations in ensuring that every vehicle provides the performance necessary to provide the requisite level of safety to all purchasers. Because only an FMVSS can ensure that all vehicles are equipped with technologies and vehicle designs that meet the specified performance requirements, NCAP can supplement but not substitute for the FMVSS. The FMVSS remains NHTSA's core way of ensuring that all motor vehicles provide the requisite level of safety performance, and provide it within a practicable timeframe. Although the NCAP program provides valuable safety-related information to consumers in a simple and easy-to-understand manner, the agency believes that the proposed rule is necessary to achieve the highest level of pedestrian safety feasible and at the fastest achievable timeframe based on the performance requirements and lead time specified in the proposed rule. Additional discussion on the NCAP RFC is provided later in this preamble.

Third, this rulemaking proposing FMVSS No. 228 is intended to work hand-in-hand with the growth and expansion of automatic emergency braking (AEB) technologies. An AEB system uses various sensor technologies and sub-systems that work together to detect when the vehicle is in a crash imminent situation, to automatically apply the vehicle brakes if the driver has not done so, or to apply more braking force to supplement the driver's braking. AEB systems were originally developed to detect a crash imminent situation with a lead vehicle, but AEB is in a state of rapid advancement and some of the systems on the market now also warn about, and respond to, an imminent collision with a pedestrian. Pedestrian AEB (PAEB) systems are designed to stop the vehicle automatically before striking a pedestrian or reduce the speed at which an impact occurs if the vehicle's initial speed is too high to avoid impact. On May 9, 2024, NHTSA published a final rule requiring AEB and PAEB systems on light vehicles which adopts FMVSS No. 127.<sup>4</sup> FMVSS No. 127 builds on a voluntary commitment, announced by NHTSA in March 2016, by 20 vehicle

manufacturers to make lead-vehicle AEB a standard feature on light vehicles, though that commitment did not include PAEB.<sup>5</sup> When new vehicles are equipped with PAEB, we anticipate that fewer pedestrians will be struck. For some impacts that cannot be avoided due to the closing speed of the vehicle (the relative speed between the vehicle and what it is approaching, in this case, the pedestrian), PAEB will lower the vehicle's speed so more impacts will be at speeds of 40 km/h (25 mph) or less, which is the velocity range FMVSS No. 228 is designed to replicate. FMVSS No. 228 would address those crashes and ensure the vehicles mitigate the risk of serious to fatal head injury in these impacts.<sup>6</sup> PAEB will eliminate many pedestrian impacts and reduce the impact of those crashes that do occur. This NPRM, if adopted, would further reduce the risk of serious injury or death from head injuries if a pedestrian strikes the hood of a vehicle. NHTSA has accounted for the effect of FMVSS No. 127 in estimating the economic impacts of this rulemaking.

This NPRM proposes FMVSS No. 228 and aligns with the goals of DOT's January 2022 National Roadway Safety Strategy, which describes the five key objectives of the Department's Safe System Approach: safer people, safer roads, safer vehicles, safer speeds, and post-crash care. FMVSS No. 228 would mandate requirements for safer vehicles and leverage advanced crash avoidance technology like PAEB in conjunction with the crashworthiness countermeasures based on GTR 9 to realize far-reaching improvements to pedestrian safety. NHTSA also notes that although research into vulnerable

<sup>5</sup> The 20 vehicle manufacturers represent more than 99 percent of the U.S. market. The commitment was to have AEB on virtually all (at least 95 percent) new passenger cars, light trucks, and MPVs with a GVWR of 8,500 pounds or less no later than September 1, 2022, and a standard feature on virtually all light trucks and MPVs with a GVWR between 8,501 pounds and 10,000 pounds no later than Sept. 1, 2025. Most manufacturers met the 2022 mark, but some did not (<https://www.iihs.org/news/detail/three-more-automakers-fulfill-pledge-to-make-autobrake-nearly-universal>). Other agency data indicate about 87% of production has PAEB. <https://www.transportation.gov/NRSS/SaferVehicles>. The voluntary commitment did not involve a pedestrian AEB component. NHTSA's NPRM would require an AEB system that detects and reacts to both lead vehicles and pedestrians and would increase the lead-vehicle performance required of AEB over that described in the voluntary commitment.

<sup>6</sup> Yanagisawa, M., Swanson, E., Azeredo, P., & Najm, W.G. (2017, April). Estimation of potential safety benefits for pedestrian crash avoidance/mitigation systems. (Report No. DOT HS 812 400). Washington, DC: National Highway Traffic Safety Administration. [https://www.nhtsa.gov/sites/nhtsa.gov/files/documents/812400\\_pcambenefits\\_report.pdf](https://www.nhtsa.gov/sites/nhtsa.gov/files/documents/812400_pcambenefits_report.pdf).

*Pedestrian safety: assessment of crashworthiness test procedures* (Report No. DOT HS 813 518). National Highway Traffic Safety Administration.

<sup>2</sup> NHTSA has proposed a roadmap for the agency's plans to upgrade NCAP in phases over the next several years. 87 FR 13452, March 9, 2022, extension of comment period, 87 FR 27200.

<sup>3</sup> 88 FR 34366, May 26, 2023. The proposed NCAP pedestrian protection program would incorporate crashworthiness tests similar to those used by the European New Car Assessment Programme (Euro NCAP). Euro NCAP's tests are closely aligned with those in GTR 9.

<sup>4</sup> 88 FR 38632, Docket NHTSA-2023-0021. The NPRM applies to passenger vehicles with a GVWR of 4,536 kg (10,000 lb) or less. The action can also be found in the Unified Agenda of Regulatory and Deregulatory Actions, RIN 2127-AM37.

road users and vehicle safety measures has focused predominantly on improving the protection of pedestrians, several effectiveness studies have concluded that pedestrian safety measures like this NPRM's head protection requirements would also be beneficial for cyclists.<sup>7</sup>

Issuance of this NPRM is also consistent with the goals of the November 15, 2021, Infrastructure Investment and Jobs Act (IIJA).<sup>8</sup> Section 24211 of IIJA, "Global Harmonization," states that the Secretary shall cooperate, to the maximum extent practicable, with foreign governments, nongovernmental stakeholder groups, the motor vehicle industry, and consumer groups with respect to global harmonization of vehicle regulations as a means for improving motor vehicle safety. This NPRM proposes to adopt an FMVSS for pedestrian head protection founded on Global Technical Regulation No. 9, "Pedestrian Safety" (GTR 9). NHTSA collaborated with experts from around the world to develop GTR 9. Establishing an FMVSS based on a Global Technical Regulation aligns with the goals of IIJA Section 24211.

Although GTR 9 was established in 2008 when light trucks and vans (LTVs), which includes large light trucks, MPVs (including SUVs) and vans, were not as common as they are now in the U.S., LTVs did exist then, and the GTR test procedure included in proposed FMVSS No. 228 was developed to be relevant and applicable to these LTV vehicles. The test procedure proposed for use in FMVSS No. 228 is relevant for use with all light vehicles in the U.S. fleet because it is based on a Wrap Around Distance (WAD) measurement appropriate for use with passenger cars and LTVs. The defined "Hood Area" (subject to proposed FMVSS No. 228 coverage) is based on WAD, so any differences in head impact locations for a given crash scenario between LTVs and passenger cars are accounted for in the WAD-based test. As described in sections V.-VII., in the proposed test, NHTSA would use impactor testing to simulate a head-to-hood or head-to-fender top impact. It would specify the use of two different impactors: one representative of the head of a struck 6-year-old child (child headform) and another representative of the head of a struck 50th percentile adult male pedestrian (adult headform). The WAD

measurement assures that the areas of the hood subject to impactor testing are the areas likely to be struck by a pedestrian's head. NHTSA has performed the WAD-based test of GTR 9 on a wide variety of vehicles, including LTVs of various shapes and sizes. These data have been used to generate the benefit-cost analysis for this NPRM, which NHTSA discusses in the Preliminary Regulatory Impact Analysis (PRIA) accompanying this NPRM. The PRIA, discussed in detail in sections below, calculates benefits and costs separately for passenger cars and LTVs.

Because the WAD-based test procedure of the GTR is technically suitable for small and large vehicles, this NPRM's regulatory text reflects the wording of GTR 9 to show the GTR's provisions implemented in a Federal motor vehicle safety standard. Throughout this preamble, however, NHTSA requests comments on the pros and cons of various aspects of the NPRM's regulatory text, particularly with respect to the areas of the vehicle that would be subject to headform testing strictly using the GTR procedure. Throughout this preamble, NHTSA focuses readers on ways NHTSA believes the proposed regulatory text could be enhanced in a final rule to achieve more safety benefits in the U.S. For example, we discuss an approach of potentially extending the test area to the grille area on all large vehicles where the head of a child or shorter adult pedestrian may be struck. With pedestrian injury and fatality rates climbing, and with lessons learned from NHTSA's NCAP and other NCAP programs engaged in headform testing of vehicle front ends, NHTSA seeks to design FMVSS No. 228 to be as effective as possible to address pedestrian safety needs in the U.S.

Accordingly, this NPRM discusses specific approaches that NHTSA is considering to possibly tailor the GTR text for a final rule. While the NPRM's regulatory text reflects the GTR's approaches and provides a framework for an FMVSS based on those provisions, NHTSA may determine to make changes in any final rule. Ultimately, NHTSA seeks to issue a final rule that would "fully meet the need in the U.S. for vehicle safety."<sup>9</sup>

### A. This Proposed Standard

In collisions between vehicles and pedestrians, the pedestrian is typically struck from the side while walking across the vehicle's path. When a pedestrian is struck in this manner, the first point of contact typically occurs between the front-end of the vehicle and the lateral aspect of the pedestrian's leg near the knee region. As the lower leg becomes fully engaged with the vehicle's front-end, the leading edge of the hood strikes the lateral aspect of the pedestrian's pelvis or upper leg. Then, as the lower leg is kicked forward and away from the front-end of the vehicle, the pedestrian's upper body swings abruptly downward towards the hood until the head strikes the vehicle. Research indicates that the linear head impact velocity ranges between 60 and 110 percent of the initial contact velocity.<sup>10</sup>

Proposed FMVSS No. 228 is designed to mitigate injuries to pedestrians hit from the side as described above. Most pedestrian injuries (79%) and fatalities (83%) are caused by the frontal structures of vehicles.<sup>11</sup> Roughly two-thirds of these occur when vehicle travel speeds are less than 40 km/h (25 mph).<sup>12 13</sup> Crash data show that pedestrian head injuries occur due to contacts to all areas of vehicle front ends, including the hood.<sup>14 15</sup> The location the pedestrian's head strikes is dependent on the pedestrian's size, the front configuration of the vehicle, and the speed of impact. In a 40 km/h (25 mph) impact, roughly 15% of pedestrian fatalities involve the pedestrian's head contacting the Hood Top. This NPRM focuses on mitigating head injuries sustained from contacting the hood and adjacent areas around the hood on the vehicle front end.

Proposed FMVSS No. 228 would use impactor testing simulating a head-to-

<sup>10</sup> Mizuno K et al. (2001), Summary Of IHRA Pedestrian Safety WG Activities—Proposed Test Methods To Evaluate Pedestrian Protection Afforded By Passenger Cars.

<sup>11</sup> See table II.1.

<sup>12</sup> Rosen E, Sander U (2009) Pedestrian fatality risk as a function of car impact speed. *Accident Analysis and Prevention*, 2009;41:536–542.

<sup>13</sup> Stammen JA et al (2002), A Demographic Analysis and Reconstruction of Selected Cases from the Pedestrian Crash Data Study, Paper No. 2002-01-0560, SAE International, Warrendale PA.

<sup>14</sup> Yutaka Okamoto, Tomiji Sugimoto, Koji Enomoto & Junichi Kikuchi (2003), Pedestrian Head Impact Conditions Depending on the Vehicle Front Shape and Its Construction—Full Model Simulation, *Traffic Injury Prevention*, 4:1, 74–82, DOI: 10.1080/15389580309856.

<sup>15</sup> Bahman S. Roudsari, Charles N. Mock & Robert Kaufman (2005) An Evaluation of the Association Between Vehicle Type and the Source and Severity of Pedestrian Injuries, *Traffic Injury Prevention*, 6:2, 185–192, DOI: 10.1080/15389580590931680.

<sup>7</sup> Simms CK and Wood DO (2009), *Pedestrian and cyclist impact—a biomechanical perspective*, Springer Science and Business Media, Dordrecht Heidelberg London New York; see Chapter 10: The influence of vehicle design on pedestrian and cyclist injuries.

<sup>8</sup> Public Law 117–58.

<sup>9</sup> Section I.B.1, 49 CFR part 553, appendix C, "Statement of Policy: Implementation of the United Nations/Economic Commission for Europe (UN/ECE) 1998 Agreement of Global Technical Regulations—Agency Policy Goals and Public Participation."

hood or head-to-fender top impact.<sup>16</sup> It would specify the use of two different impactors: one with a mass of 3.5 kg that is representative of the head of a struck 6-year-old child (child headform) and another with a mass of 4.5 kg representative of the head of a struck 50th percentile adult male pedestrian (adult headform). The standard would define various areas of a test vehicle<sup>17</sup> hood (such as the Hood Top and Hood Area) subject to testing in an objective and repeatable manner. The Hood Area would be partially composed of the Child Headform Test Area and the

Adult Headform Test Area. The area likely to be struck by a child pedestrian's head (the Child Headform Test Area) would be tested with the child headform and the area likely to be struck by an adult's head (the Adult Headform Test Area) would be tested with the adult headform.<sup>18</sup> The headforms would hit areas of the vehicle hood at specific speeds and impact angles replicating a real-world vehicle traveling at 40 km/h (25 mph) and impacting the adult or child pedestrian.

The following figure generally depicts the areas of a vehicle that would be subject to FMVSS No. 228 testing, particularly the Hood Top and Hood Area (which share a boundary in this example and are contained within the dashed lines), and the Child and Adult Headform Test Areas (darkly shaded areas). The figure illustrates other terms and concepts used in the proposed standard. All of the terms used in the figure are fully explained in this preamble.

BILLING CODE 4910-59-P

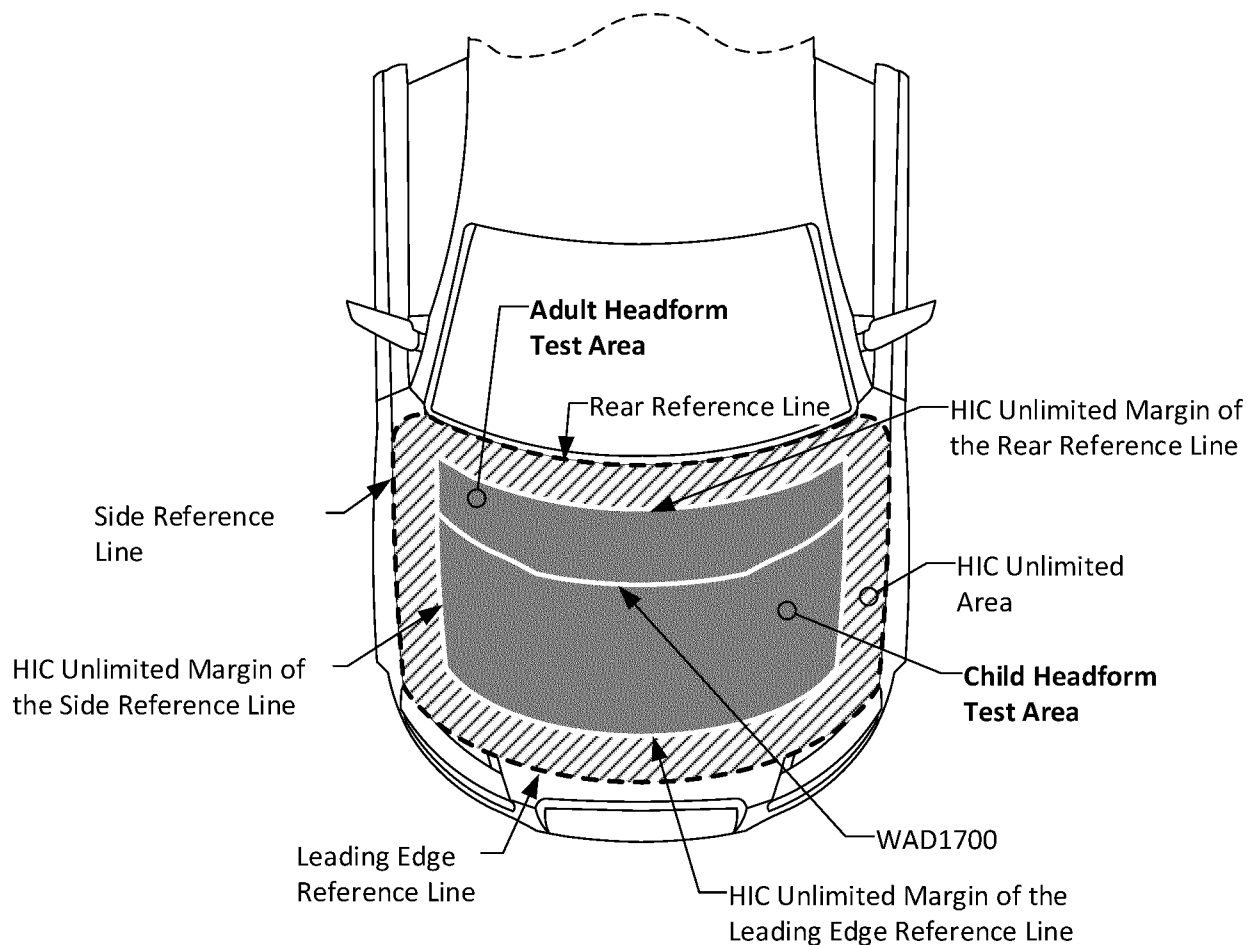

**Figure I.1. Example Child and Adult Headform Test Area outline. For illustration purposes only. Not to scale.**

BILLING CODE 4910-59-C

Proposed FMVSS No. 228 would specify performance requirements limiting the accelerations measured by

the headforms. The HIC must be less than 1000 (HIC1000) over a certain portion of the Child and Adult Headform Test Areas.<sup>19</sup> The requisite

portions would be derived as a percentage of the overall Hood Area. Generally speaking, the portion of the Child Headform Test Area that must

<sup>16</sup> We note that the "hood" as defined in proposed FMVSS No. 228 would typically encompass portions of the fender top.

<sup>17</sup> "Test vehicle" refers to the vehicle whose compliance with proposed FMVSS No. 228 is being assessed.

<sup>18</sup> This preamble occasionally refers to these two test areas together as the "Child and Adult Headform Test Areas."

<sup>19</sup> Injuries can be categorized according to the Abbreviated Injury Scale (AIS). AIS ranks individual injuries on a scale of 1 to 6: 1=minor,

2=moderate, 3=serious, 4=severe, 5=critical, and 6=maximum (untreatable). In previous rulemakings (notably with respect to those involving FMVSS No. 208 and FMVSS No. 214), NHTSA associated HIC1000 with an 11% risk of AIS 4+ brain injuries.

meet the HIC1000 requirement must be at least one-half of the numerical value (numerical value of the area is calculated from a projection onto a horizontal plane) of the Hood Area below what is called the “WAD1700 line.”<sup>20</sup> Based on data showing the locations of child and adult head impacts, this NPRM proposes that WAD1700 would be the boundary between the Child Headform Test Area and the Adult Headform Test Area. Secondly, the portion of the Combined Child and Adult Headform Test Areas that must comply with the HIC1000 limit must be at least two-thirds of the numerical value of the Hood Area. Because hard areas under the hood are challenging to mitigate, for practicability reasons the HIC limit for the remaining test areas is higher, but nonetheless limited to HIC1700.<sup>21</sup>

To meet the HIC limits, hoods would be required to have protective countermeasures that attenuate the energy of the impact during initial contact of the headform, and/or that provide sufficient clearance (open areas) to prevent the headform from bottoming out on objects beneath the hood. The countermeasures would have to ensure that the hood is not too stiff (such a hood would fail the HIC requirement) and not too soft (a too soft hood could also fail because the headform could penetrate down to the level of a hard, immovable structure beneath the hood). Among other objectives, an effective

design balances hood stiffness with depth of penetration.<sup>22</sup>

*B. Potential Impacts of the Rulemaking*

FMVSS No. 228 would apply to passenger cars and to MPVs, trucks, and buses with a GVWR of 4,536 kg (10,000 lb) or less.<sup>23</sup> Due to the widespread adoption and use of GTR 9 by other countries, most passenger vehicles sold in the U.S. that use international platforms already incorporate the head protection designs of the GTR. Regardless of current voluntary conformance, we propose to adopt GTR 9 into an FMVSS to ensure future vehicles provide at least the pedestrian head protections voluntarily provided today. We also seek to address the many U.S. variants and other models built upon uniquely American platforms that may or may not be designed to the GTR requirements. This includes essentially the entire pickup truck and large SUV segments (about 22% of the U.S. passenger vehicle 2020 sales, according to data provided by Wards Automotive). Our testing indicates that it is possible for some pickup trucks to pass the headform HIC requirements,<sup>24</sup> which implies domestic implementation is feasible. This proposal would ensure that uniquely American platforms, such as pickups, would provide the proposed level of pedestrian head protection. In this NPRM, NHTSA also considers modifying some aspects of GTR 9 to clarify the wording of the regulation,

improve objectivity, and potentially increase safety benefits resulting from the GTR’s application to the U.S. fleet. NHTSA proposes a domestic FMVSS No. 228 to achieve those enhancements.

This NPRM is economically significant under Executive Order 12866 due to the benefits estimated to result from the proposed standard. NHTSA’s PRIA analyzes the potential impacts of proposed FMVSS No. 228. NHTSA has placed a copy of the PRIA in the docket for this NPRM.<sup>25</sup>

NHTSA estimates that the proposal would mitigate approximately 67.4 fatalities annually, even after accounting for the effect of PAEB. (However, as explained in detail in sections below, the count of *injuries* will increase as averted fatalities are replaced by injuries.) For passenger cars, the cost per vehicle is estimated to be in the range of \$2.86–\$3.50 when discounted at 3% and 7%. Similarly, LTVs have a per vehicle cost of \$3.29–\$4.08. When discounted at 3% and 7%, the total annual cost ranges from \$48.94 to \$60.43 million. The overall discounted equivalent lives saved (ELS) range from approximately 44.46 to 54.87. Taking into account both discount rates, the cost per ELS is \$1.10 million and net benefits range from approximately \$480.79 to \$593.33 million. Table I.1 summarizes the cost and benefits for both discount rates. Additional details of the benefits and costs analysis can be found in section X.III of this preamble.

TABLE I.1—SUMMARY OF COST AND BENEFITS  
[Millions]

Discount rate	Cost	Equivalent lives saved	Cost per equivalent live saved	Monetized benefits	Net benefits
3% .....	\$60.43	54.87	\$1.10	\$653.76	\$593.33
7% .....	48.94	44.46	1.10	529.74	480.79

<sup>20</sup> FMVSS No. 228 would have detailed procedures that define the areas on the hood, including a Wrap Around Distance (WAD) procedure that identifies various reference lines on the hood. As explained in a later section, in any particular vehicle vertical longitudinal plane, the Wrap Around Distance is the distance from a point on the ground directly below the vehicle’s most forward edge in that plane, to a designated point on the hood, as measured with a flexible measuring device, such as a flexible wire. WADs of various lengths correlate to where pedestrians of different heights would hit their head on the hood when struck from the side. We can create a WAD line using wires of different lengths, e.g., a wire of 1700 +/- 1 mm can be used to draw a line at 1,700 mm from the ground reference plane (such a line is referred to as WAD1700).

<sup>21</sup> HIC1700 is associated with a 36% risk of AIS 4+ brain injuries.

<sup>22</sup> Examples of elements of designs that are beneficial to pedestrian head protection are: introducing additional clearance between the inner and outer skins of the hood, using energy-absorbing materials to improve shock absorption, redesigning stiff structures under the hood, such as hinges and headlight frames, to crush, collapse, or shear off, and redesigning the side edges of the hood where it meets up with the fenders to use a more deformable support structure or moving the stiff hood-to-fender junction out of the head impact zone. “Active hoods” have also emerged that have a front-end sensor and lever arms to automatically lift (pop up) the hood upon detecting that a pedestrian has been struck. An actuator near the hinge pops the hood slightly to provide more space between the hood and rigid components in the engine bay.

<sup>23</sup> Consistent with the GTR, the proposed regulatory text includes a provision that excludes from the standard MPVs, trucks, and buses where

the distance, measured longitudinally on a horizontal plane, between the transverse centerline of the front axle and the seating reference point of the driver’s seat, is less than 1000 mm. However, we are considering applying FMVSS No. 228 to these vehicles and are requesting comment on this issue later in the preamble.

<sup>24</sup> In headform testing of mid-2000 model year vehicles, large SUVs and pickups performed about the same as minivans, smaller SUVs, and passenger cars. For more details, see Mallory et al., (2007), Pedestrian GTR testing of current vehicles, ESV Paper No. Paper No. 07–0313. Among the vehicles tested were two pickups—a 2003 Dodge Ram and a 2005 Chevy Silverado—and neither had a head impact that exceeded the HIC limit in this NPRM.

<sup>25</sup> The PRIA may be obtained by downloading it or by contacting Docket Management at the address or telephone number provided at the beginning of this document.

## II. Safety Need

In 2020, 38,824 people died on U.S. roads. Of this number, 25,536 were passenger vehicle occupant fatalities, a decrease from 32,225 in 2000.<sup>26</sup> This reduction is notable, particularly in light of the fact that the total number of vehicle miles traveled (VMT) in the U.S. has increased over time. However, during that same timeframe, pedestrian fatalities increased by 33 percent, from 4,739 in 2000 to 6,516 in 2020.<sup>27 28</sup>

The vast majority of pedestrian fatalities (98% or 6,132) are due to a single striking vehicle.<sup>29</sup> A 2019 NHTSA report analyzed the critical events or actions related to crashes (*e.g.*, control loss, road departure), including the critical event of striking a pedestrian.<sup>30</sup> The report found that an average of 3,731 fatal crashes and a total of 70,461 crashes each year included the critical event of a vehicle striking a pedestrian (years 2011–2015). This represents 53 fatal crashes per thousand crashes, the highest among any critical events tabulated.

Most injuries resulting from collisions between vehicles and pedestrians are inflicted by the frontal structures of vehicles, the majority of which occur when vehicle travel speeds are lower than 40 km/h (25 mph) (see figure V.2). Pedestrians sustaining life-threatening injuries typically have head and thorax injuries caused by contact with the vehicle. A NHTSA study using both U.S. and German crash data found that the head and lower extremities are the

most common injury locations on a struck pedestrian.<sup>31</sup> The head, legs, and thorax are the most common locations for serious injury, and the head, legs, and pelvis/hip are the most common locations for disabling injuries. A NHTSA study analyzing the potential effect of the head, upper leg and lower leg component test procedures estimated that among serious to fatal injury cases (MAIS<sup>32</sup> 3+), 37.8 percent of the total expected potential effects of the test procedures was associated with the headform test, 24.6 percent was associated with the upper legform test and 37.6 percent was associated with the lower legform test. When the analysis was limited to more severe injuries (MAIS 4+ or fatal cases), the influence of the headform test was substantially higher, while the relative influence of the upper legform and lower legform tests was reduced.<sup>33</sup>

Studies have found a high prevalence of five crash types in collisions between vehicles and pedestrians.<sup>34</sup> These crash types are:

- Dart-out (first half)—where the pedestrian appears suddenly midblock, often from between parked cars, presents a limited exposure time to the driver and is struck less than halfway across the roadway.
- Dart-out (second half)—similar to the Dart-out (first half) except the pedestrian is struck after crossing half or more of the roadway.
- Intersection dash—where the pedestrian presents a short time exposure to the driver at an intersection either because the pedestrian runs across the intersection, is blocked from view, or crosses unexpectedly.

- Multiple threat—where a vehicle stops for a crossing pedestrian and, in so doing, blocks the pedestrian from the view of the driver in a second car that is overtaking the first car (includes intersection and midblock situations).

- Vehicle turn/merge—where the driver is concentrating on turning into or merging with traffic and does not see the pedestrian.

New Federal Motor Vehicle Safety Standard No. 228, *Pedestrian head protection*, (FMVSS No. 228) has proposed test procedures designed to replicate head-to-hood contact in the crash sequences described above. The procedures replicate a child or adult pedestrian crossing a street and being struck from the side by a vehicle travelling at a speed approaching 40 km/h (25 mph).

FMVSS No. 228 would affect vehicles involved in the majority of fatal pedestrian crashes: passenger cars, light trucks (pickups), and MPVs (vans, crossover vehicles and SUVs) (see table II.1). Sales are trending toward more non-passenger cars. Light trucks and MPVs as a percentage of light vehicle sales have steadily increased from 52% in 2011 to 77% in 2020.<sup>35</sup>

In a pedestrian crash, the vehicle striking the pedestrian is usually the only vehicle involved; the vast majority are single vehicle collisions in which the vehicle-to-pedestrian collision is the only harmful event. For fatalities, of front end striking vehicle types, there is about an even split between passenger cars (43 percent) and light trucks and MPVs (42 percent). Large trucks (GVWR greater than 4,536 kg (10,000 lb)), which are not covered by this proposal, are responsible for 6 percent of fatal front end to pedestrian strikes. Buses (covered by this NPRM only if they have a GVWR of 4,536 kg (10,000 pounds) or less) are responsible for 0.5 percent of fatal strikes and the remaining fatal strikes (8 percent) are caused by unknown vehicle types. The percentages for non-fatal injuries show a different distribution, with passenger cars representing 58 percent of front end striking vehicles and light trucks representing 40 percent.

<sup>26</sup> Traffic Safety Facts 2020 “A Compilation of Motor Vehicle Crash Data.” U.S. Department of Transportation. National Highway Traffic Safety Administration.

<sup>27</sup> Traffic Safety Facts 2000 “A Compilation of Motor Vehicle Crash Data from the Fatality Analysis Reporting System and the General Estimates System.” U.S. Department of Transportation. National Highway Traffic Safety Administration.

<sup>28</sup> National Center for Statistics and Analysis. (2021, October), *Early Estimate of Motor Vehicle Traffic Fatalities for the First Half (January-June) of 2021*. (Traffic Safety Facts. Report No. DOT HS 813 199). Washington, DC: National Highway Traffic Safety Administration.

<sup>29</sup> NHTSA Fatality Analysis Reporting System (FARS).

<sup>30</sup> Swanson, E., Foderaro, F., Yanagisawa, M., Najm, W.G., & Azeredo, P. (2019, August). Statistics of light-vehicle pre-crash scenarios based on 2011–2015 national crash data (Report No. DOT HS 812 745). Washington, DC: National Highway Traffic Safety Administration.

<sup>31</sup> Mallory, A., Fredriksson, R., Rosen, E., Donnelly, B. (2012, October). Pedestrian Injuries By Source: Serious and Disabling Injuries in US and European Cases. 56th AAAM Annual Conference.

<sup>32</sup> MAIS stands for Maximum Abbreviated Injury Scale.

<sup>33</sup> Mallory, A., Yarnell, B., Kender, A., & Stammen, J. (2019, May). Relative frequency of U.S. pedestrian injuries associated with risk measured in component-level pedestrian tests (Re-port No. DOT HS 812 658). Washington, DC: National Highway Traffic Safety Administration.

<sup>34</sup> Snyder and Knoblauch (1971); Hunter WW et al. (1995), Pedestrian and Bicycle Crash Types; DaSilva MP et al., (2003), Analysis of Pedestrian Crashes, Report No. DOT HS 809 585, April 2003, Washington DC, NHTSA; Thomas L et al. (2014), North Carolina pedestrian crash types, 2008–2012, University of North Carolina Highway Safety Research Center, March 2014.

<sup>35</sup> Wards Automotive.

TABLE II.1—PEDESTRIAN INJURIES AND FATALITIES IN SINGLE VEHICLE FRONT END CRASHES BY VEHICLE TYPE, 2020

Class of vehicle	Injuries		Fatalities	
Passenger car .....	23,158 (58%)	38,961 (98%)	1,972 (43%)	3,941 (85%)
Light Truck and MPV .....	15,803 (40%)		1,969 (42%)	
Large Truck .....			274 (6%)	
Bus .....			21 (0.5%)	
Unknown/other .....		959 (2%)	386 (8%)	
Totals (front end) .....		39,921 (100%)	4,622 (100%)	
Totals (all impact locations) .....		50,397	5,536	

Sources: NHTSA’s Fatal Accident Reporting System (FARS) and National Automotive Sampling System—General Estimates System (GES). NHTSA’s Traffic Safety Facts Sheet.

In 2020, of all motor-vehicle related fatalities and injuries (including drivers, passengers, pedestrians, etc.) pedestrians accounted for 16 percent of all fatalities and 4 percent of injuries in the under 16 age group; pedestrians

accounted for 12 percent of all motor vehicle-related fatalities and 2 percent of injuries in the age group 16–34; and pedestrians accounted for 19 percent of fatalities and 3 percent of injuries in the age group 35–44. For the age groups of

45–64 and 65 and older, the fatality figures were 21 percent and 18 percent, respectively. Injuries for these two groups were both 3 percent.

TABLE II.2—PEDESTRIANS AS A PERCENTAGE OF ALL TRAFFIC FATALITIES AND INJURIES IN 2020 BY AGE GROUP

Years old	Percent of traffic fatalities	Percent of traffic injuries
15 and Under .....	16	4
16–34 .....	12	2
35–44 .....	19	3
45–64 .....	21	3
65 and Over .....	18	3

Sources: FARS and GES.

This proposal addresses the injuries and fatalities resulting from head impacts to the front of the vehicle. The derivation of the target population is described in detail in the PRIA accompanying this proposal. A summary of the PRIA is contained in section XIII of this proposal.

**III. Foundations for the Proposal**

NHTSA protects pedestrians through rulemaking, consumer information provided by the agency’s New Car Assessment Program, safety research, and public education programs to improve safe driving and walking practices.<sup>36</sup> With respect to rulemaking, a number of vehicle standards have been issued for pedestrian safety, such as FMVSS No. 111 (49 CFR 571.111), which has rear visibility requirements that manufacturers must meet through backup cameras, and which requires outside rearview mirrors and their mountings to be free of sharp points or edges that could injure pedestrians. FMVSS No. 131 (49 CFR 571.131) applies to school bus stop arms that control traffic around children boarding or unloading from school buses. NHTSA recently amended FMVSS No. 108 (49

CFR 571.108) to permit the installation of adaptive driving beam requirements that help to improve roadway illumination so drivers can more easily detect pedestrians and motorcyclists.<sup>37</sup> NHTSA additionally expects that FMVSS No. 127, recently published final rule requiring PAEB, would have substantial benefits in preventing collisions with pedestrians and reducing the speed of impacts.

*NHTSA’s Efforts on a Pedestrian Head Protection Standard*

Over many years, NHTSA has studied the feasibility of additional countermeasures to reduce the severity of pedestrian leg, upper body, and head injuries. In 1981, NHTSA issued an NPRM<sup>38</sup> to limit the amount of force that may be exerted by a striking vehicle’s bumper area on an adult pedestrian’s lower leg in a 32.2 km/h (20 mph) crash. The rulemaking was later terminated when the potential countermeasure (a softer bumper) did not prove practicable.<sup>39</sup> A decade later, NHTSA had plans for an NPRM for head impact protection but discontinued

regulatory work in that area at that time.<sup>40</sup>

NHTSA, however, continued its research into child and adult pedestrian protection. The agency collaborated closely with other countries to harmonize international procedures and requirements,<sup>41</sup> and carried out key pedestrian research and data collection with international stakeholders such as the International Organization for Standards (ISO),<sup>42</sup> the International Harmonization of Research Activities (IHRA),<sup>43</sup> the European Commission

<sup>40</sup> NHTSA held a public meeting on August 20, 1991, to seek public input on the agency’s plans for a pedestrian protection regulation. Only the hood requirements were discussed at this meeting. In response to NHTSA’s pedestrian safety plan presented at the meeting, all motor vehicle manufacturers indicated at least some major redesign would be required to meet the headform requirements. Based on such comments, unknowns about the benefits projected, the high costs of major vehicle redesign, and several other factors (such as international harmonization, pedestrian behavior enforcement, better infrastructure, and other crash avoidance measures), the agency did not proceed with the head impact protection rulemaking.

<sup>41</sup> 61 FR 58362, November 14, 1996.

<sup>42</sup> ISO is a worldwide standards-setting organization to facilitate the international exchange of goods and services.

<sup>43</sup> IHRA was an inter-governmental steering committee formed to facilitate multi-national collaboration in research in major problem areas of road safety, including pedestrian safety. The IHRA expert group on pedestrian safety developed test

<sup>36</sup> <https://www.nhtsa.gov/road-safety/pedestrian-safety>.

<sup>37</sup> 87 FR 9916; February 22, 2022.

<sup>38</sup> 46 FR 7015; January 22, 1981.

<sup>39</sup> 69 FR 14496, April 10, 1991.

(E.C.), and the European Enhanced Vehicle Safety Committee (EEVC).<sup>44</sup> NHTSA was a key contributor to the development of Global Technical Regulation No. 9 (GTR 9) for pedestrian protection. This NPRM proposes to incorporate GTR 9 into a new FMVSS No. 228, to include pedestrian crashworthiness head protection requirements in the FMVSS for the first time.

#### IV. The Global Technical Regulation

##### A. Introduction

On June 25, 1998, the U.S. became the first signatory to the “Agreement Concerning the Establishing of Global Technical Regulations for Wheeled Vehicles, Equipment and Parts which can be Fitted and/or be Used on Wheeled Vehicles,” commonly referred to as the 1998 Agreement.<sup>45</sup> The 1998 Agreement was negotiated under the auspices of the United Nations Economic Commission for Europe (UNECE) under the leadership of the U.S., the European Community (EC) and Japan. The 1998 Agreement provides for the establishment of global technical regulations (GTRs) regarding the safety, emissions, energy conservation and theft prevention of wheeled vehicles, equipment and parts.

By establishing GTRs under the 1998 Agreement, governmental organizations (Contracting Parties) seek to harmonize motor vehicle regulations at the regional and national levels.<sup>46</sup> Under the 1998 Agreement, Contracting Parties voting in favor of establishing a GTR are obligated to “submit the technical Regulation to the process” used in the country to

procedures to assess the vehicle-to-pedestrian collision.

<sup>44</sup> The EEVC does not set standards or enforce regulations and is not a part of the European Commission (E.C.). The EEVC can only recommend safety standards to the E.C. and other legislative states, which may or may not develop them into regulations. The EEVC carries out auto safety research in a number of specialized areas called “Working Groups.” Research within a Working Group, overseen by a steering committee of representatives from Europe’s national governments, is carried out by nominated technical experts who may also work for the automotive industry. Funding for EEVC research is typically provided as “in-kind” contributions from the groups represented by the steering committee members and technical experts.

<sup>45</sup> The 1998 Agreement is administered by the UN Economic Commission for Europe’s World Forum for the Harmonization of Vehicle Regulations (WP.29). <https://www.unece.org/fileadmin/DAM/trans/main/wp29/wp29wgs/wp29gen/wp29glob/globale.pdf>. The 1998 Agreement entered into force on August 25, 2000.

<sup>46</sup> Non-governmental organizations may also participate in a consultative capacity in groups developing GTRs. Manufacturers may participate through non-governmental organizations representing industry. Individual manufacturers may also provide input to the process.

adopt the requirement into the agency’s law or regulation.<sup>47</sup> In the United States, that process usually commences with an NPRM, Advance NPRM (ANPRM), or Request for Comment. Under the terms of the 1998 Agreement, contracting parties are *not* obligated to adopt the GTR after initiating this process.<sup>48</sup> The 1998 Agreement recognizes that governments should have the authority to determine whether the GTR meets their safety needs.

In deciding whether to adopt a GTR as an FMVSS, NHTSA follows the applicable procedural and substantive requirements for rulemaking, including the Administrative Procedure Act, the National Traffic and Motor Vehicle Safety Act (Safety Act) (49 U.S.C. 301), Presidential executive orders, and DOT and NHTSA policies, procedures and regulations.<sup>49</sup> Under § 30111(a) of the Safety Act, Federal Motor Vehicle Safety Standards must be practicable, meet the need for motor vehicle safety, and be stated in objective terms.<sup>50</sup> Section 30111(b) states that, when prescribing such standards, NHTSA (by delegation at 49 CFR 1.95) must, among other things, consider all relevant, available motor vehicle safety information, consider whether a standard is reasonable, practicable, and appropriate for the types of motor vehicles or motor vehicle equipment for which it is prescribed, and consider the extent to which the standard will further the statutory purpose of reducing traffic crashes and associated deaths and injuries.

##### B. GTR 9

In developing GTR 9, NHTSA collaborated with experts from contracting parties to the 1998 Agreement,<sup>51</sup> particularly the European

<sup>47</sup> Article 7, 1998 Agreement.

<sup>48</sup> *Id.*

<sup>49</sup> NHTSA’s policies in implementing the 1998 Agreement are published in 49 CFR part 553, appendix C, “Statement of Policy: Implementation of the United Nations/Economic Commission for Europe (UNECE) 1998 Agreement on Global Technical Regulations—Agency Policy Goals and Public Participation.” NHTSA’s paramount policy goal under the 1998 Agreement is to “[c]ontinuously improve safety and seek high levels of safety, particularly by developing and adopting new global technical regulations reflecting consideration of current and anticipated technology and safety problems.” *Id.*

<sup>50</sup> “Motor vehicle safety” is defined in the Safety Act as “the performance of a motor vehicle or motor vehicle equipment in a way that protects the public against unreasonable risk of accidents occurring because of the design, construction, or performance of a motor vehicle, and against unreasonable risk of death or injury in an accident, and includes nonoperational safety of a motor vehicle.” 49 U.S.C. 30102(a)(9).

<sup>51</sup> The 1998 Agreement entered into force in 2000 and is administered by the UN Economic

Union (technical sponsor of the GTR<sup>52</sup>) and Japan. This NPRM begins the process of adopting the GTR as a NHTSA standard through rulemaking.

A number of countries have implemented GTR 9.<sup>53</sup> Even before GTR 9 was established, Europe and Japan had similar pedestrian protection regulations in place. After GTR 9 was established, WP.29 adopted it as a full UNECE regulation for all nations under the 1958 Agreement (Regulation No. 127—Pedestrian Safety Performance).<sup>54</sup> In recent years, U.S. variants share similar global designs as vehicles currently sold in the E.U. that attain the levels of head protection described in GTR 9. However, as discussed later, interpretation of certain GTR 9 provisions have varied when implemented into national regulations.

GTR 9 has two sets of performance requirements: (a) for the hood top and fenders tested by a headform impact; and (b) for the vehicle front-end area (encompassing the bumper and grille) tested by a legform impact. Vehicle hoods conforming to the GTR’s specifications mitigate child and adult pedestrian head injury, and bumpers and grilles conforming to the GTR reduce the risk of adult leg injury. This NPRM proposes to implement the GTR’s provisions for the hood top and fenders. The May 6, 2023, NCAP RFC proposed to amend NHTSA’s NCAP program to

Commission for Europe’s World Forum for the Harmonization of Vehicle Regulations (WP.29). <https://www.unece.org/fileadmin/DAM/trans/main/wp29/wp29wgs/wp29gen/wp29glob/globale.pdf>.

<sup>52</sup> <https://unece.org/fileadmin/DAM/trans/doc/2004/wp29/TRANS-WP29-AC3-07e.pdf>.

<sup>53</sup> GTR 9 has been amended several times, but the U.S. has not been a signatory to any of the amendments or corrigenda. Thus, in general, this NPRM focuses on the original GTR and not later amendments. The first amendment was related to the applicability of vehicles with short hood areas and increased the number of vehicles excluded from the requirements of GTR 9. We discuss this provision and exclusion in section V.B. of this NPRM. At the same time, a corrigendum was accepted that clarified that the HIC areas may be broken up into pieces and need not be continuous. This is a concept that NHTSA had assumed was part of the GTR; this NPRM explicitly incorporates this concept in the proposed regulatory text (see also section VII.B of this NPRM). Finally, the GTR was amended to replace the leg impactor with a more advanced tool. This amendment relates to provisions that are outside of the scope of this NPRM. <https://unece.org/transport/standards/transport/vehicle-regulations-wp29/global-technical-regulations-grs>.

<sup>54</sup> The U.S. is not a party to the 1958 Agreement. A contracting party to the 1958 Agreement can choose which regulation(s) it wants to adopt, but the regulations in the 1958 Agreement must be adopted “as is.” They do not contain different stringency levels. Also, the 1958 Agreement provides for reciprocal recognition of type approvals among Contracting Parties. This means that a vehicle type that has been type approved by one Contracting Party must be accepted by other 1958 Agreement Contracting Parties.



include Euro NCAP-based provisions for the hood, bumper, and grille. Those head, bumper, and grille Euro NCAP provisions correspond closely to GTR 9.<sup>55</sup> NHTSA is considering comments to the NCAP RFC in deciding whether and how to proceed with GTR 9's leg protection requirements in an FMVSS.

This rulemaking initiates the process of adopting GTR 9 into the Federal safety standards. This NPRM proposes to implement the head protection requirements of GTR 9 as FMVSS No. 228. The proposed standard modifies some of the GTR's provisions to address the regulatory framework and needs unique to the United States. From years of researching pedestrian head protection using the procedures described in the GTR and applying the procedures to the front-end designs of today, NHTSA has seen instances where the GTR is silent or unclear about its application to some aspects of hood design. Because clarity is needed for the FMVSS, NHTSA has addressed these areas with detailed procedures and criteria in this NPRM that, by design, are consistent with the GTR and with NHTSA's Safety Act provisions. NHTSA has incorporated these clarifications into proposed FMVSS No. 228 so that the standard's procedures are objective and repeatable and meet the need for safety, in accordance with Safety Act requirements. As discussed throughout this document, this NPRM also focuses readers on other ways NHTSA is considering modifying the GTR test procedures for clarity or to push more safety benefits from the U.S. fleet. An example of the latter is NHTSA's consideration of narrowing the border surrounding a test area so that more of the vehicle's hood and fender area would have to meet the HIC requirements.

### C. Further Observations About the Differences Between This NPRM and the GTR

In drafting FMVSS No. 228, NHTSA's goal has been to produce a proposal that is true to the agency's understanding of GTR 9 and to the technical best practices provided by the GTR, so as to "fully meet the need in the U.S. for vehicle safety."<sup>56</sup> We believe we have

achieved this with this NPRM, but at times we have found challenges in relating the original GTR 9 language to the specificity necessary for the self-certification framework of the Safety Act. The Safety Act requires the FMVSS to be practicable, meet the need for motor vehicle safety, and be stated in objective terms. Additionally, the Safety Act requires that NHTSA consider specific factors in prescribing an FMVSS.<sup>57</sup> Given these requirements and considerations, in some instances we have found the need to define terms and describe test procedures in a more precise way than GTR 9, but in a way that would add to the objectivity and clarity of the safety standard.

NHTSA has also shaped this proposal to provide the minimum level of safety required to address the needs we face in this country. NHTSA is aware that other countries have implemented the regulation in some ways that differ from our reading of the regulation in ways that reduce the safety minimum even further. For example, this NPRM adds clarification regarding how the agency will determine the amount of testable hood area that must meet a head injury criterion (HIC) of 1000 or less, compared to a HIC of 1700 or less. This is described more fully in section VI.A of this preamble. UNECE Reg. No. 127 has implemented the GTR 9 in a way that produces a smaller area that must comply with HIC1000 than that which results from the GTR as NHTSA understands it, or as NHTSA proposes in this NPRM to address the growing pedestrian safety needs in this country. In section VIII of this preamble, we provide a detailed discussion of a proposed amendment to GTR 9 that NHTSA has not supported because of its potential to reduce the area subject to headform testing. NHTSA discusses throughout this preamble the differences between this proposed FMVSS No. 228 and the current GTR 9, and the reasons for those differences.<sup>58</sup> Finally, NHTSA seeks to design FMVSS No. 228 to address pedestrian safety needs particular to the U.S. The regulatory text in this NPRM reflects the wording of the GTR. At the end of various sections, however (see, e.g.,

section VI.C.1), the preamble describes and requests comment on specific ways NHTSA may change the regulatory text in this rulemaking to better address this country's pedestrian safety needs.

## V. Approach of the Proposed Standard

### A. Overview

FMVSS No. 228 would prohibit vehicles from exceeding a certain HIC level when subjected to testing simulating a head-to-hood impact. The standard is designed to provide head protection to a walking child and a walking adult when side-struck. This posture was chosen because it represents one of the most common interactions between vehicles and pedestrians. The side-struck posture is also regarded as "worst case."<sup>59</sup> Hoods would have to safely absorb and manage the energy of the striking pedestrian's head.

The proposed standard defines each hood as having two distinct areas: one where a struck child pedestrian's head would impact (Child Headform Test Area) and one where an adult pedestrian's head would impact (Adult Headform Test Area), both in a 40 km/h (25 mph) vehicle impact. The proposed performance requirements are based on HIC as computed from the acceleration of the headform upon impact. FMVSS No. 228 would limit HIC when tested with the headforms.

The location of a pedestrian's head impact on the hood is dependent on several variables, including the speed of the vehicle impact, the vehicle front-end shape, and the height of the pedestrian. Proposed FMVSS No. 228 is designed so that vehicle countermeasures to meet the HIC limits would benefit pedestrians of all sizes. In section VI of this preamble, we explain in detail the specific areas of the hood that would be regulated under the proposal, as well as considerations for expanding this area.

Proposed FMVSS No. 228 includes detailed procedures that define reference lines on the vehicle from which NHTSA would calculate the area of the vehicle that must provide pedestrian head protection. Proposed FMVSS No. 228's wrap around distance (WAD) procedure is a simple procedure used in several sections of GTR 9 to identify various reference lines on the hood. Reference lines that run laterally across the hood are drawn relative to a specified WAD. Those lines are referred to herein as WAD lines. NHTSA helped develop the WAD procedure for

<sup>55</sup> Test procedures very similar to GTR 9 have been incorporated into many countries' consumer information programs. In addition to Euro NCAP, Japan's J-NCAP program rates vehicles on pedestrian safety, using a headform test, as do the Korean KNCAP and Australasian ANCAP programs.

<sup>56</sup> Section I.B.1, 49 CFR part 553, appendix C, "Statement of Policy: Implementation of the United Nations/Economic Commission for Europe (UN/ECE) 1998 Agreement of Global Technical Regulations—Agency Policy Goals and Public Participation," *supra*.

<sup>57</sup> 49 U.S.C. 30111(a) and (b).

<sup>58</sup> In advance of the publication of this NPRM, NHTSA received a July 7, 2022 letter from the Alliance for Automotive Innovation restating support of the interpretation of the GTR 9 that aligns with the proposed GTR amendment. On December 9, 2022, NHTSA met with the Alliance of Automotive Innovation at their request, to discuss the contents of their letter to NHTSA. The letter can be found in the docket, along with a list of other contacts since April 2022. The agency's position and rationale are fully explained in this preamble, particularly in section VIII.B.

<sup>59</sup> Soni A, Rober T, Beillas P (2013), Effects of Pedestrian Pre-Crash Reactions on Crash Outcomes during Multi-body Simulations, 2013 IRCOBI Conference, Paper No. IRC-13-92.

pedestrian protection test programs internationally.

The WAD is the distance from a point on the ground directly below the bumper's most forward edge, at a specific lateral location, to a designated point on the hood, as measured with a flexible measuring device, such as a non-stretch flexible wire. During measurement of the WAD, the device (the non-stretch flexible wire) is held taut, to measure distances while being held in a vertical longitudinal (x-z)

vehicle plane. A WAD of a specified distance can identify a point on the vehicle's hood. A WAD line can be drawn on a vehicle by connecting the end points of the wire as it traverses across the front of the vehicle. We can create a WAD line using wires of different lengths, *e.g.*, a wire of  $1000 \pm 1$  mm can be used to draw a line at 1,000 mm from the ground reference plane (such line is referred to as "WAD1000" in this NPRM),  $1700 \pm 1$  mm ("WAD1700") and  $2100 \pm 1$  mm

("WAD2100").<sup>60</sup> See figure V.1, below, illustrating how WAD is measured.

A WAD line can be objectively determined and is a good indicator of where head impacts are likely to occur on any particular hood.<sup>61</sup> The WAD measurement accounts for both pedestrian height and vehicle front-end configuration. That is, in a 40 km/h crash, a given pedestrian's head-to-hood contact point is approximated by the WAD that corresponds to the pedestrian's standing height.

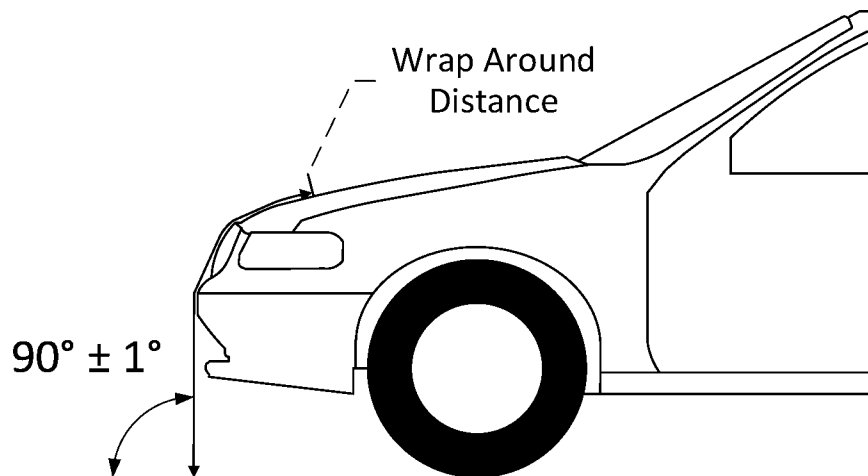

**Figure V.1. Wrap Around Distance measurement.**  
For illustration purposes only.

#### Key Elements of the Proposal

The proposed standard has certain key elements to replicate the real-world 40 km/h (25 mph) impact in an objective and enforceable manner. The key elements are:

- Relevance to the vehicles involved in pedestrian crashes at 40 km/h (25 mph);
- A methodology incorporating component testing of the hood using headforms representing child and adult pedestrians;
- Performance requirements based on HIC as measured by the headforms;
- A hood mark-off procedure to denote test areas; and
- Flexibility in performance requirements to address practicality challenges.

These key elements and others are discussed in detail below.

#### B. Relevance to the Involved Vehicles

FMVSS No. 228 would apply to passenger cars, and to MPVs, trucks, and buses with a GVWR of 4,536 kg (10,000 lb) or less, except for vehicles with short front ends (a very short front hood area). Proposed FMVSS No. 228 would also apply to bidirectional vehicles, *i.e.*, vehicles that can be operated in either direction. We discuss these issues below.

##### Vehicles With Short Front Ends

Reflecting the text of GTR 9, the NPRM's proposed regulatory text (S3) excludes MPVs, trucks, and buses where the distance, measured longitudinally on a horizontal plane, between the transverse centerline of the front axle and the seating reference point (SgRP) of the driver's seat, is less than 1,000 mm.<sup>62</sup> In the statement of technical rationale for GTR 9, the drafters argued that these vehicles have a very short

hood and a front shape that is very close to vertical, so the pedestrian kinematics with these vehicles are believed to be very different than a collision with a vehicle with a longer hood. The drafters also concluded that there are difficulties in applying the tests to these vehicles, particularly regarding the determination of test zone reference lines.

NHTSA drafted the regulatory text with this exclusion, but NHTSA requests comments on whether the subject vehicles should be included in FMVSS No. 228. Notwithstanding the drafters' reasons for excluding the vehicles from GTR 9, NHTSA believes applying proposed FMVSS No. 228 to these vehicles may be appropriate given developments since the GTR. With the advent of new designs in electric vehicles, including designs of automated vehicles on the road today with very short front ends, front end designs appear to be evolving to less

<sup>60</sup>The naming convention is to follow "WAD" with the length of the wire used for the measurement, and to refer to WAD [wire length] to refer to the line drawn by using the wire and the WAD procedure.

<sup>61</sup> Paragraph 71 of the "Safety Need" section of GTR 9. <https://unece.org/fileadmin/DAM/trans/main/wp29/wp29wgs/wp29gen/wp29registry/ECE-TRANS-180a9e.pdf>.

<sup>62</sup>This is dimension L114 in SAE J1100 "Motor Vehicle Dimension." A later amendment to GTR published in 2011, which was not signed by the U.S., extended this dimension to 1,100 mm. (ECE/TRANS/180/Add.9/Amend.1/appendix 1).

conventional hood designs. The agency is aware of prototype ride-share automated vehicle platforms, such as the Cruise Origin and Zoox, and of electric vehicles (EVs) being marketed by Canoo, that have a very short front hood area or a flat front face.<sup>63</sup> We are concerned that future automated and/or electric vehicles may become more prevalent in the fleet and that they could be excluded from the standard simply because of this GTR provision.

In addition, we base our concerns about this exclusion on present day vehicles and their presence in the U.S. vehicle fleet. The agency took an available selection of vehicles and measured the horizontal distance from the front axle to the seat bight (the area close to and including the intersection of the surfaces of the vehicle seat cushion and the seat back), with the seat adjusted to the full forward and full rearward position. The vehicles and resulting dimensions are provided in table V.1, below. The position of the SgRP for these vehicles was not readily

available, but the distance between the axle and the SgRP would likely lie somewhere between the range of distances measured to the seat bight. As stated above, the GTR 9 exclusion would be triggered if the distance from the front axle to the SgRP is less than 1,000 mm.

The agency found that at least one type of full-size cargo van (Ford Transit) could possibly qualify for the exclusion. Looking at both small and full-size cargo and passenger vans, it is clear that many of them share similar design attributes of a short hood and a relatively forward seating position with respect to the front wheels.<sup>64</sup> This suggests to the agency that the most likely types of vehicles in the current fleet that would be excluded are small and large vans. For 2021, this van segment had a sales volume of approximately 400,000 vehicles, constituting about 2.7% of the 15 million total 2021 sales.<sup>65 66</sup> Thus, the 2.7% value provides an upper bound on the number of vehicles likely to meet the exclusion criteria. It also seems clear

to the agency that relatively minor changes in design could place a vehicle in the excluded category. We are concerned about the effects of the exclusion in reducing the benefits of this proposal.

NHTSA has tested a vehicle with a short front end similar to vehicles in the excluded category and has successfully conducted headform testing. This testing demonstrated that the proposed WAD-based test procedure can be applied to short front end vehicles. NHTSA also believes it would be practicable for the vehicles to meet the proposed standard. NHTSA tested the 2004 GMC Savana van to a slightly modified version of the GTR 9 test protocol, with a 32 km/h head impact speed. Three of four hood impacts had a HIC below 600. The fourth test, near the edge of the hood had a HIC of less than 1000.<sup>67</sup> These results suggest that FMVSS No. 228 would be practicable for similar vehicles.

TABLE V.1—SAMPLE OF VEHICLE’S HORIZONTAL DISTANCE FROM THE FRONT AXLE TO SEAT BIGHT

Year	Make/model	Approximate distance to seat bight (mm)	
		Full forward	Full rearward
2015	Ford Transit	930	1180
2016	Honda Fit	1200	1480
2003	Honda Pilot LX	1250	1500
2016	Nissan Rogue	1270	1480
2011	Chevrolet Cruze	1300	1550
2012	Ford Focus	1320	1570
2001	Honda Civic	1330	1530
2012	Ford Fusion	1380	1760
2006	Infiniti M35	1400	1650
2002	Jeep Wrangler	1680	1880

We request comments on the practicability concerns related to these vehicles, specific challenges such vehicles present related to the proposed test procedure, and what adjustments, if any, would be available to apply proposed FMVSS No. 228 to such vehicles. We also request comments on the safety need and outcomes of including all light vehicles under the proposed standard to maximize potential safety benefits to pedestrians and other vulnerable road users.

Rear Engine Vehicles and Bidirectional Vehicles

It is the agency’s intent to apply FMVSS No. 228 to rear engine vehicles, as long as they meet the other applicability requirements. This is because the location of the tested area is not dependent on where the engine is located, but rather is keyed to the front of the vehicle. We believe GTR 9 is intended to apply to such vehicles.

A similar assumption cannot be made about whether GTR 9 is intended to cover bidirectional vehicles. Certainly, there is no explicit mention of these vehicles. Nonetheless, it is NHTSA’s

intent to apply FMVSS No. 228 to bidirectional vehicles. NHTSA believes that such vehicles may become more common, particularly with the advent of more automated vehicle platforms, and that there is a safety need to apply proposed FMVSS No. 228 to the vehicles because they could strike pedestrians. Therefore, we have explicitly made the definitions and regulatory text of proposed FMVSS No. 228 neutral concerning the direction of vehicle operation, *i.e.*, the regulatory text is intended to work for bidirectional vehicles. First, we have explicitly included bidirectional vehicles in the

<sup>63</sup> NHTSA understands that the Cruise Origin and Zoox vehicles do not have a traditional driver’s seating position.

<sup>64</sup> Some vehicles in this category would be the Chevrolet Express, Ford E-Series, Ford Transit, Ford Transit Connect, GMC Savana, Mercedes-Benz

Metris, Mercedes-Benz Sprinter, Nissan NV, Nissan NV200, Ram ProMaster, Ram ProMaster City.

<sup>65</sup> <https://www.goodcarbadcar.net/2021-us-commercial-van-sales-figures-by-model/>.

<sup>66</sup> <https://www.goodcarbadcar.net/2021-us-vehicle-sales-figures-by-model/>.

<sup>67</sup> Stammen J, et al, “Pedestrian Head Safety Survey of U.S. Vehicles In Support of the Proposed Global Technical Regulation (GTR)” (2006). <https://unece.org/DAM/trans/doc/2008/wp29/WP29-144-03e.pdf>.

Applicability section of the proposed regulatory text. Next, we have defined “bidirectional” vehicle to mean a vehicle that is intended to operate at similar speeds and with similar maneuverability in both directions of the vehicle longitudinal axis.<sup>68</sup> Similarly, we have defined “front” to mean the leading portion of the vehicle during full speed operation. We seek comment on whether the terms accomplish the agency’s objective of including bidirectional vehicles in FMVSS No. 228.

### C. Advantages of Headform Component Tests

The NPRM proposes using headform component tests rather than full vehicle dynamic tests in which a vehicle would strike a pedestrian dummy. The agency believes that headform component tests have advantages over full vehicle dynamic tests. The area of the vehicle hood that could contact a pedestrian’s head is large. A set of headform component tests enables NHTSA to target hood areas that the agency

believes represent danger points, and test with a high degree of accuracy and repeatability. Like all crashes, every real-world pedestrian crash is unique in some way. When the range of statures and other crash variables are taken into account, the area of the vehicle that could contact the head is so large that currently the only feasible test method is one that is based on a sub-system test approach. Proposed FMVSS No. 228 uses such an approach by focusing on the hood and by making use of a set of headform component tests that can target the hood area efficiently. The headform mass, impact angle, and impact speed can all be controlled in a way that will assure that the standard will provide safety in real world impacts and can be enforced. The characteristics of the headforms are discussed in detail later in this preamble.

Pedestrian test dummies have been developed for crashworthiness research. In general, the repeatability of tests using a pedestrian dummy is relatively

poor because small variations in initial positioning influence the head-to-hood contact as the dummy passes through its sequence of movements after being struck by the vehicle. Moreover, head impact locations are highly dependent on stature and gait, so use of a single pedestrian dummy for crashworthiness purposes would make it very difficult to assess hood areas that are likely to be struck by persons not represented by the dummy.

### D. Head Injury Criterion (HIC)

Consistent with GTR 9, NHTSA has determined that HIC is an appropriate injury criterion for the proposed standard. The proposed standard would require HIC to be less than 1000 for most hood impacts. HIC is calculated using the expression below, where the resultant acceleration,  $a_r$ , at the headform center of gravity and specified as a multiple of  $g$  (the acceleration of gravity), is integrated over 15 millisecond ranges covering the entire impact.

$$HIC = \left[ \frac{1}{t_2 - t_1} \int_{t_1}^{t_2} a_r dt \right]^{2.5} (t_2 - t_1)$$

HIC, which is a function of the tri-axial linear acceleration in the headform, is well established and used in numerous occupant protection FMVSS. A HIC value of 1000 represents an 11 percent risk of a brain injury of severity level AIS 4 or greater and a HIC value of 1700 represents a 36 percent risk.<sup>69</sup> Many of NHTSA’s impact protection standards use HIC to measure the potential for head injury and limit HIC to a value of 1000; these include FMVSS No. 201, *Occupant protection in interior impact*, FMVSS No. 214, *Side impact protection*, and FMVSS No. 222, *School bus passenger seating and crash protection*. NHTSA considered other brain injury metrics, such as angular velocity, but determined that HIC is the best available criterion at this time.<sup>70</sup>

Proposed FMVSS No. 228 would require vehicles to meet HIC limits

when subjected to hood headform impactor testing. It defines the forward, rear and side areas of the hood, thus defining a primary area—the “Hood Top.”<sup>71</sup> From there, a typically smaller “Hood Area” is defined using, among other things, the Wrap Around Distance lines described earlier. Of this Hood Area, the standard would define a Child Headform Test Area and an Adult Headform Test Area, excluding margins at the side and potentially at the front and rear, which would be tested with the child and adult headforms, respectively. The HIC must not exceed 1000 (HIC1000) over a certain portion of the Child and Adult Headform Test Areas, as a percentage of the overall Hood Area. Specifically, the portion of the Child Headform Test Area that must meet the HIC1000 provision must be at least one-half of the numerical value of

the Hood Area with a Wrap Around Distance of less than 1,700 mm (WAD1700).<sup>72</sup> Secondly, the portion of the Combined Child and Adult Headform Test Areas that must not exceed the HIC1000 provision must be at least two-thirds of the numerical value of the Hood Area. For practicability reasons to accommodate a manufacturing need to reinforce and stiffen the hood edges, the remaining test area is permitted to have HIC higher than 1000, but nonetheless limited to 1700 for both headforms.<sup>73</sup>

*HIC time window, 15 ms.* Proposed FMVSS No. 228 would reference a 15 millisecond (ms) time window when applying the HIC criterion. For any 15 ms time window, HIC must be below the HIC criterion (e.g., HIC1000). A 15 ms time window is used in proposed FMVSS No. 208 verses a longer window

<sup>68</sup> The terms of this definition are intended to distinguish these vehicles from conventional vehicle that can also operate in two directions. However, for conventional vehicles the rearward or backing direction is not intended for full speed operation, but rather low speed and typically in a single gear.

<sup>69</sup> AIS (Abbreviated Injury Scale) ranks individual injuries by body region on a scale of 1 to 6: 1=minor, 2=moderate, 3=serious, 4=severe, 5=critical, and 6=maximum (untreatable).

<sup>70</sup> In an actual vehicle-pedestrian collision, head rotation that occurs before, during, or after the head impact with the hood could result in concussive brain injuries. However, the biofidelity of a headform—unattached to the body—could be compromised in its ability to generate angular velocity representative of an actual pedestrian head impact. The agency would like to understand more about the biofidelity of a headform when used to measure angular velocity.

<sup>71</sup> The procedures for defining these areas are discussed below in this preamble.

<sup>72</sup> The drafters of the GTR determined that because the location of necessary under-hood components cannot be fundamentally changed, it is unavoidable that they are located in the child headform test area. Thus, the GTR provides that the relaxation zone for the child headform test area may be half of the zone (as opposed to 1/3 of the zone, as in the adult test area).

<sup>73</sup> Such reasons include the need to minimize any fluttering of the hood at high speeds and the ability to slam the hood shut without deforming the seams at the junction of the hood and fender.

(e.g., using a 36 ms timeframe) because the FMVSS No. 228 impact is hard and of short duration. Longer duration impacts may have a greater HIC when using a 36 ms window (a longer duration impact can occur in air bag tests when the test dummy's head maintains contact with the air bag through a crash event). For hard, short duration impacts such as the headform testing used in proposed FMVSS No. 228, HIC derived from a 15 ms timeframe produces the same numerical value as HIC derived from a longer window (36 ms). Since the FMVSS No. 228 impact is hard and of short duration, a 15 ms window is appropriate.

Further, GTR 9 uses a 15 ms window instead of 36 ms to improve the objectivity of the test. The 15 ms window was viewed as a common-sense safeguard against signal corruption due to a secondary impact. With hood impacts, there is a risk that the headform may undergo a secondary impact in rapid succession (in less than 36 ms), as the head could strike the hood target then bounce away and land on a structure such as the windshield, which is outside of the test area. To safeguard against the effects of a secondary impact, the 15 ms criterion was implemented as a convenient means to help assure that the HIC value reflects only that portion of the headform acceleration caused by a hood impact within the test area. The procedures developed by IHRA, ISO, and the EEVC all use a 15 ms window to calculate HIC. This criterion and threshold have been carried over to all subsequent international standards.

#### Request for Comment on HIC

- We generally agree with the approach and have proposed it in this NPRM. However, we would like to know more about the following issues.

We have not seen a need to use a 15 ms window, as opposed to a 36 ms window, because head impacts to external car structures are very short, occurring within a few milliseconds of contact. In practice, 15 ms and 36 ms windows generally have produced the same value in pedestrian protection tests. Further, in our own testing, we have not observed an instance where the use of a 36 ms window would have led to signal corruption due to a secondary impact. We request comment on the need for a 15 ms timeframe related to testing issues.

- We also seek comment on whether a 15 versus 36 ms window could affect HIC measurements when testing active hoods or cowl air bags,<sup>74</sup> features that have appeared in recent years, particularly in non-U.S. vehicles. We request comments on whether HIC computed in a 36 ms timeframe would be more appropriate and protective against head injury for vehicles with active hoods or air bag technologies than HIC computed in a 15 ms window. Should FMVSS No. 228 adopt a HIC 36 ms timeframe to account for these technologies?

#### E. Speed and Angle at Which the Headforms Would Impact the Hood

The headforms would impact the vehicle hood at specific speeds and impact angles replicating a real-world 40 km/h (25 mph) impact.

##### 1. Headform Impact Speed

Proposed FMVSS No. 228 would require the launch direction to be entirely within the plane parallel to the vehicle x-z plane (vertical longitudinal plane) and the impact speed for both headforms would be 35 km/h (22 mph).<sup>75</sup> This speed is based on observations of postmortem human subjects (PMHS) and pedestrian surrogate testing, computer modeling,

and reconstructions of real-world pedestrian collisions. The proposed velocity of 35 km/h (22 mph) replicates the actual head-to-hood impact speed of a pedestrian struck by a vehicle traveling at 40 km/h (25 mph).<sup>76</sup>

The proposed test speed encompasses the majority of pedestrian collisions. About 70 percent of injurious pedestrian collisions occur at vehicle speeds of 40 km/h (25 mph) or less (see figure V.2, which averages data from 2011 to 2020).<sup>77</sup> In addition, the 35 km/h (22 mph) test speed is a critical part of the real-world event replicated by the headform impact test. The dynamics of a pedestrian-vehicle interaction change at a target speed substantially greater than 40 km/h (25 mph). Above 40 km/h (25 mph), an initial hood-to-torso interaction takes place where the pedestrian tends to slide along the hood, with the head overshooting the hood. The head-to-hood interaction that the proposed test procedure replicates would lose its real-world relevance if a substantially higher test speed were used.

The proposed test speed addresses a safety need within the bounds of practicability. Although pedestrian fatalities, on average (50% cumulative value in figure V.2), occur at a collision speed of 70 km/h (44 mph), the practicability of designing a hood to conform to HIC1000, based on energy dissipation, appears to become less feasible at a headform impact speed of 61 km/h (38 mph) (assuming the same ratio of head speed to vehicle speed used from the proposal, the 61 km/h would have about 3 times the energy). Moreover, the proposed rule would reduce the severity of many head injuries that occur at speeds covered by the test.

**BILLING CODE 4910-59-P**

<sup>74</sup> The cowl is the lower edge of the windshield opening. Active hoods move when a pedestrian impact is sensed, increasing the distance between the hood and the hard engine components below. A cowl air bag covers the cowl during a pedestrian impact.

<sup>75</sup> The vehicle coordinate system used in this NPRM is consistent with SAE J1100 "Motor Vehicle Dimension." The coordinate system is as follows: +x direction is the longitudinal vehicle axis (rearward direction of travel); +y direction is the lateral vehicle axis (pointing away from the right side of the vehicle); +z direction is pointing vertically upward.

<sup>76</sup> Researchers have historically used the ratio of head impact speed to vehicle speed to characterize the head-to-hood interaction. A head impact speed of 35 km/h (22 mph) in a 40 km/h (25 mph) collision yields a ratio of 0.875. Depending on conditions, such as the shape of the vehicle front-

end, the height of the leading edge of the hood, and the height of the pedestrian, the ratio for an adult may be as high as 1.4 or as low as 0.7.

<sup>77</sup> Mizuno Y, Ishikawa H (2001), Summary of IHRA pedestrian safety WG activities—proposed test methods to evaluate pedestrian protection afforded by passenger cars, Paper No. 280, The 17th International Technical Conference on the Enhanced Safety of Vehicles, Amsterdam, The Netherlands, June 4–7, 2001.

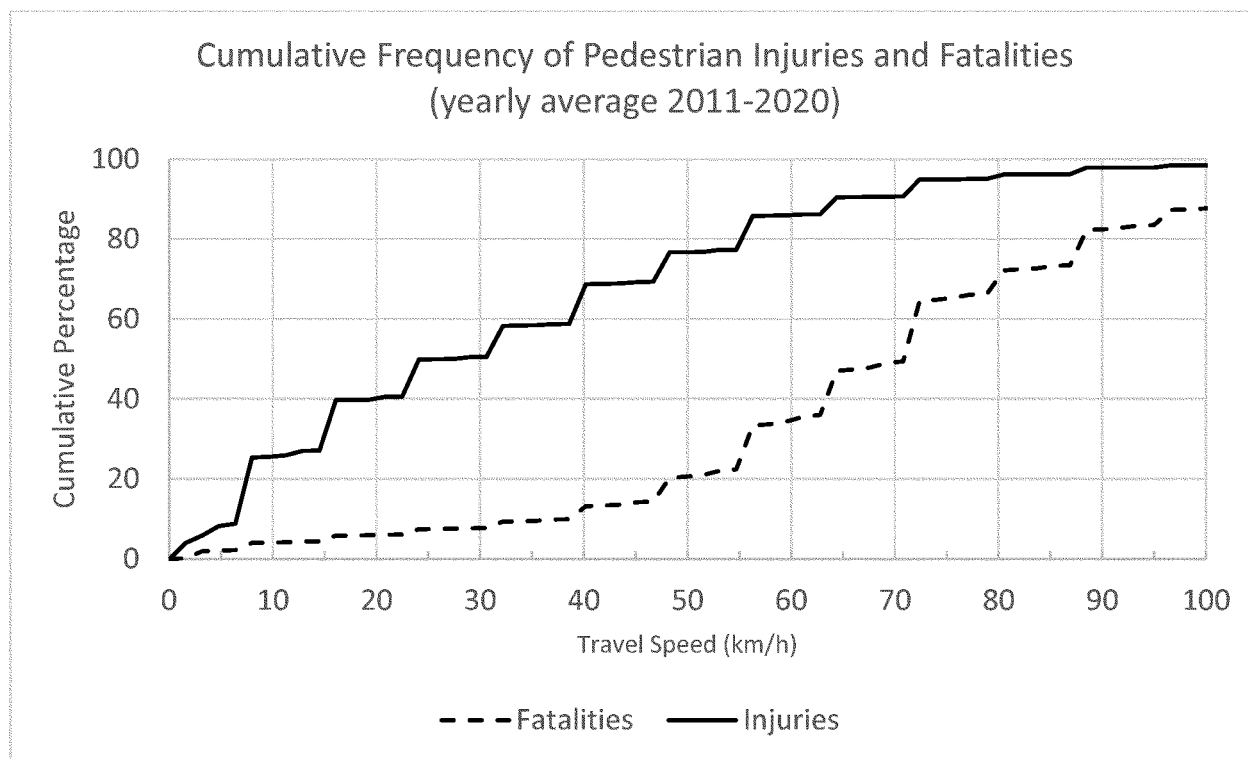

**Figure V.2. Distributions of pedestrian injuries and fatalities by vehicle travel speed, Annual Average of 2011 - 2020. Sources: FARS and GES.**

**BILLING CODE 4910-59-C**

Notwithstanding the proposed headform test speed of 35 km/h (22 mph), NHTSA believes there would be benefits from the proposed standard for some crashes above a 40 km/h (25 mph) vehicle speed, as the countermeasures used to meet the proposed HIC thresholds could mitigate some of the harm resulting from head-to-hood strikes that can occur in the higher speed crashes. Also, vehicle designs that provide head protection in a 35 km/h (22 mph) headform impact may also have the effect of reducing the severity of injuries to body regions other than the head in collisions at vehicle speeds above 40 km/h (25 mph). For example, at vehicle to pedestrian collision speeds of 50 km/h (31 mph) and higher, bilateral rib fractures have been observed in thorax-to-hood contacts.<sup>78</sup> We request comment on whether some of these types of injuries could be mitigated by hood designs meeting FMVSS No. 228.

NHTSA anticipates PAEB would mitigate 238 fatalities and 2,672 injuries of the current target population for this

NPRM and has based our benefits estimate for this NPRM on that assumption. Automatic emergency braking helps prevent crashes or reduce their severity by applying a vehicle's brakes automatically. The systems use on-board sensors to detect an imminent crash, warn the driver, and apply the brakes if the driver does not take action quickly enough or increase the braking application in the case that the driver does not sufficiently brake to avoid contact. When new vehicles are equipped with PAEB that meets the requirements specified in FMVSS No. 127, fewer pedestrians will be struck, which would have the effect of reducing the target population for this rulemaking. On the other hand, for many impacts that occur at speeds too high for PAEB to completely mitigate, PAEB will lower the vehicle's speed so that impact speeds that would have been greater than 40 km/h (25 mph) could be reduced to close to or below 40 km/h (25 mph). This would theoretically add to the target population of this rulemaking because these are pedestrian crashes that this proposed pedestrian head protection standard could potentially address. And, as proposed FMVSS No. 228 would ensure the striking vehicles have protective features that protect against

serious to fatal head injury in these impacts, those pedestrians that would be newly included in the target population of this NPRM due to PAEB could arguably be included among those saved from serious to fatal injury by this head protection rulemaking. However, we have not accounted for the extent to which the FMVSS No. 127 would add to the target population or to the population of persons benefiting from this head protection NPRM because of unknowns about how those benefits could be quantified. As a result, our analysis likely underestimates benefits. With this in mind, in the PRIA we estimate that PAEB would decrease the fatality target population addressed by FMVSS No. 228 by about 4 percent. Comments are requested on this issue.

- NHTSA requests comments on increasing the test velocity above 35 km/h (22 mph) to capture a greater percentage of pedestrian impacts presented in the field data and achieve additional safety benefits.

## 2. Headform Impact Angle

Consistent with the GTR, NHTSA proposes that, at impact, the velocity vector of the child headform would form a 50-degree angle down from the horizontal ( $50^\circ \pm 2^\circ$  at the time of impact). For the adult headform, the

<sup>78</sup> Watanabe A et al (2011), Research of collision speed dependency of pedestrian head and chest injuries using human FE model (THUMS version 4), 22nd International Technical Conference on the Enhanced Safety of Vehicles (ESV), Paper No. 11-0043, Washington DC, June 2011.

angle would be 65 degrees ( $65^\circ \pm 2^\circ$  at the time of impact). (See figure V.3, showing the child headform impact and

figure V.4, showing the adult headform impact).

BILLING CODE 4910-59-P

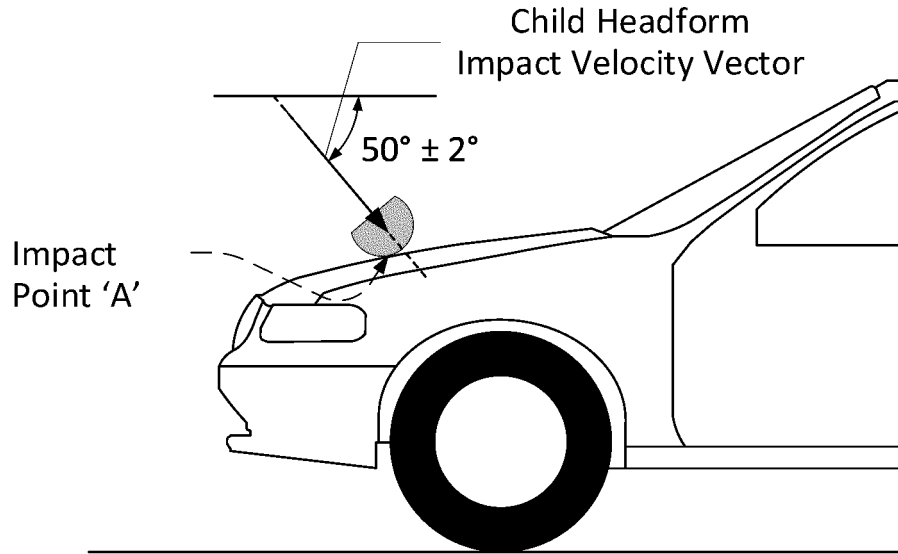

**Figure V.3. Impact angle and impact point of the child headform. (For illustration purposes only.)**

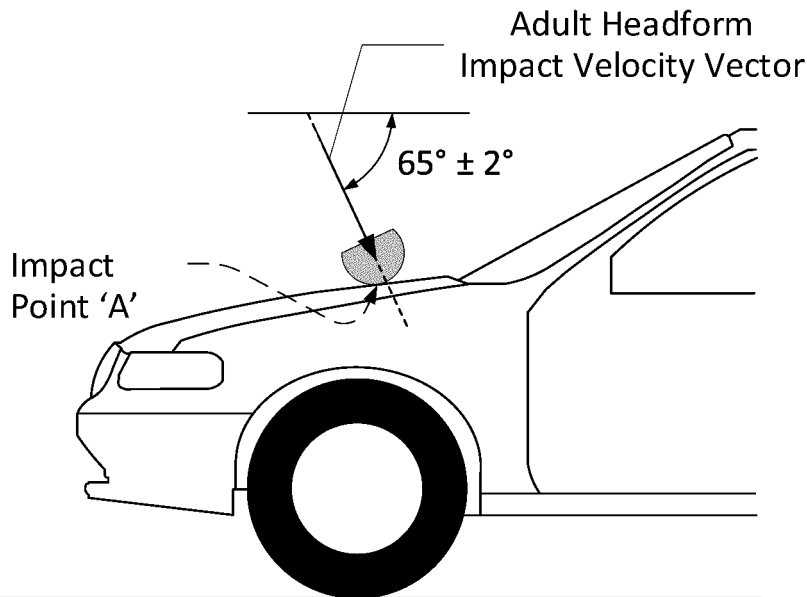

**Figure V.4. Impact angle and impact point of the adult headform. (For illustration purposes only.)**

BILLING CODE 4910-59-C

The head impact angles were developed based on observations of PMHS and pedestrian dummy tests, computer modeling, and reconstructions of real-world pedestrian collisions. The impact angle in a real-world impact is greater for taller pedestrians than for

shorter pedestrians, and this is reflected in the test procedure. The impact angle in real-world impacts also varies depending on the shape of the vehicle front-end, particularly the height of the leading edge of the hood. Passenger cars (with low leading edges) generally

produce head-hood angles that are closer to 90 degrees than SUVs.

The proposed 65-degree impact angle for the adult headform test is the same as the IHRA specification. The bulk of research data showed head impact angles in the range of 50 to 80 degrees; IHRA selected a nominal headform

angle of 65 degrees.<sup>79</sup> Component tests conducted by NHTSA<sup>80</sup> showed that HIC sensitivity to impact angle varied with hood stiffness and proximity to hard understructures. Where there were no hard understructures, HIC values exhibited very little sensitivity to impact angle. In general, HIC variation of less than 10 percent was shown between 50 and 80 degrees.

The selection of a 50-degree impact angle for the child headform test was partly based on computational simulations using a 5th percentile adult female (which is about the same size as an average 12-year-old child)<sup>81</sup> and a 6-year-old child. The simulation results for the 5th percentile female gave similar average values to those found for the 50th percentile adult male. For the 6-year-old, however, simulations showed that the head impact angle was more sensitive to car shape, particularly to the height of the hood leading edge. An average value of 45 degrees was found for the 6-year-old. The 50-degree impact angle is representative of the simulation results with a bias towards the 6-year-old child.

#### Request for Comment on the Proposed Impact Angle

- We believe that the headform impact test would be the most stringent when the impact is normal to the hood surface (a 90-degree angle of incidence to the surface).<sup>82</sup> If the impact is normal (90 degrees) and there is no glance-off, all of the headform's energy would have to be absorbed by the hood to stop its downward movement. However, a 90-degree angle of incidence to the surface may not be consistent with real world impacts at speeds up to 40 km/h (25 mph) and would require the impactor launch angle to vary by test location. We request comment on whether the standard should increase the impact angles to increase stringency notwithstanding a possible reduction in the representativeness of real-world crashes.

## VI. Defining the Relevant Areas Subject to the Standard

*Overview:* Proposed FMVSS No. 228 would have detailed procedures that define reference lines on the vehicle from which NHTSA would calculate the area of the vehicle that must provide pedestrian head protection. The proposed procedures (including the WAD procedure) are needed to enable the agency to objectively define the areas on the vehicle that are subject to the standard, the total HIC1000 area that must be provided, and the locations of the Child and Adult Headform Test Areas. The procedures are necessary for NHTSA to assess a test vehicle's compliance with the standard. NHTSA would use the procedures to define these relevant areas and would not use manufacturer input to define them.

As relevant areas are defined in the following section of this NPRM, any necessary clarification to GTR 9 will be identified and described. Although the various hood reference lines should be essentially identical to those in GTR 9, the terminology used to describe the areas and reference lines are not identical. A more complete comparison of the terminology used in GTR versus this NPRM can be found in section VIII.

The areas subject to the standard are the areas likely to be impacted by the head of a pedestrian and for which countermeasures are or could reasonably be available. The most severe head injuries can be due to contact anywhere on the hood surface.<sup>83</sup> Consistent with GTR 9, the first step in establishing these areas would be to identify the "Hood Top."<sup>84</sup> The Hood Top forms the basis upon which all other areas are determined. We discuss the method for determining the Hood Top in section VI.A below. The next step would be to establish the "Hood Area" using the procedures discussed in section VI.B below.<sup>85</sup> The final step in the process would be to determine the test areas, *i.e.*, the Child and Adult Headform Test Areas. As part of this

process, consistent with GTR 9's 82.5 mm margins, the standard would identify "HIC Unlimited Areas"<sup>86</sup> and exclude them from meeting HIC limits. While the agency is unaware of data that indicates there is a lower likelihood of pedestrian head contact in this area compared to other areas of the hood, the GTR and proposed standard provide for HIC Unlimited Areas as a practicability measure to accommodate a manufacturing need to reinforce and stiffen the hood edges.<sup>87</sup> The HIC Unlimited Area bounds the Child and Adult Headform Test Areas at the hood edge.

Portions of the Child and Adult Headform Test Areas are either subject to HIC1000 or HIC1700 limits. The requisite HIC1000 area that is calculated based on the total Hood Area must be located within the Child and Adult Headform Test Areas and are not part of the HIC Unlimited Area. Proposed FMVSS No. 228 would provide manufacturers considerable leeway in determining where to place the HIC1700 area to afford them as much flexibility as reasonably possible in configuring the structures comprising their underhood designs. The vehicle manufacturer would inform NHTSA of the locations of the HIC1700 areas. NHTSA would use that information to confirm that sufficient HIC1000 area has been provided, delineate the HIC1700 areas, and confirm through headform test results that the appropriate HIC limits are met.

### A. Determining the Hood Top

The Hood Top is enclosed by the intersection of the following borders (these borders are depicted in figure VI.1 below):

- *Front border:* Leading Edge Reference Line.
- *Side border:* Side Reference Lines.
- *Rear border:* Rear Reference Line.

**BILLING CODE 4910-59-P**

<sup>79</sup> Because the typical hood is angled forward at about 15 degrees, it causes the 65 degree adult headform impact to create an 80 degree angle of incidence with the hood, *i.e.*, a slightly angled (non-normal) headform impact.

<sup>80</sup> Stammen JA, Saul RA, Ko B (2001), Pedestrian head impact testing and PCDS reconstructions, Paper No. 326, 16th International Technical Conference with the Enhanced Safety of Vehicles (ESV) Proceedings, Amsterdam, The Netherlands, June 4-7, 2001.

<sup>81</sup> Janssen and Nieboer, Sub-system tests for assessing pedestrian protection based on computer

simulations, Proceedings of the IRCOBI Conference, Berlin, September 1991.

<sup>82</sup> Assuming that a 15 degree hood angle is typical, a 90 degree head-hood angle would correspond to a 75 degree headform impact angle from the horizontal.

<sup>83</sup> Koetje B and Grabowski J. A Methodology for the Geometric Standardization of Vehicle Hoods to Compare Real-World Pedestrian Crash; Annuals of Advances in Automotive Medicine. 2008; 52: 193-198.

<sup>84</sup> The Hood Top is identical to the "Bonnet Top" of GTR 9.

<sup>85</sup> As we will describe below, in some instances the Hood Area may be equivalent to the Hood Top.

<sup>86</sup> NHTSA would use the procedures in the standard to identify the HIC Unlimited areas and would not use manufacturer data to define them. We note that GTR 9 does not use the "HIC Unlimited" terminology, but makes the same reduction to the testable area.

<sup>87</sup> As noted earlier, such reasons include the need to minimize any fluttering of the hood at high speeds and the ability to slam the hood shut without deforming the seams at the junction of the hood and fender.



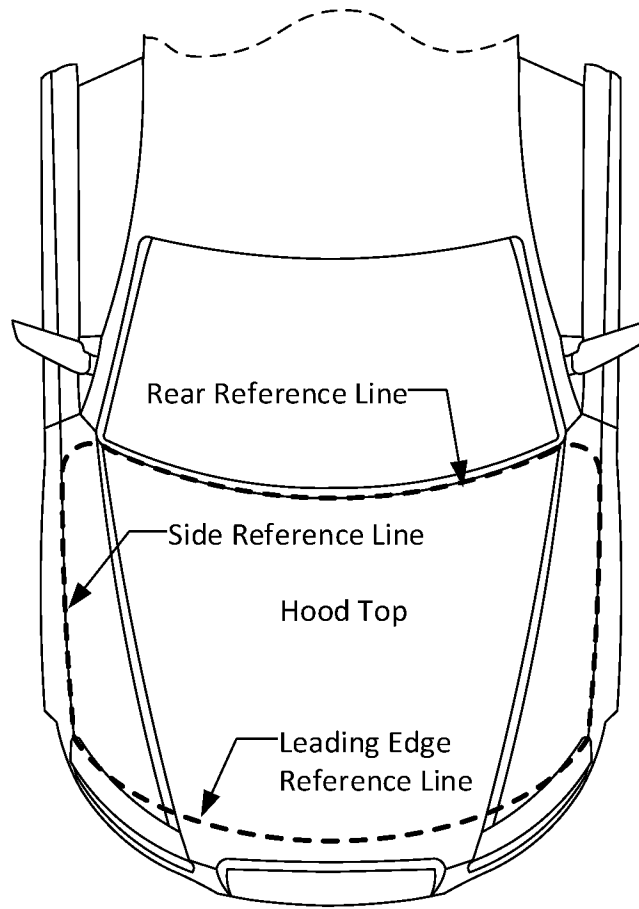

**Figure VI.1. Example Schematic of Hood Top.  
For illustration purposes only.**

#### 1. Front Border of the Hood Top

The front border of the Hood Top would consist of the vehicle's "Leading Edge Reference Line" (LERL). The LERL is determined for most vehicles by running a 1,000 mm straight edge angled at 40° (down from the horizontal) along the front edge of the vehicle. The lower end of the straight edge is specified to be 600 mm off the ground.

The specified height of 600 mm was chosen to avoid the bumper when marking off the hood leading edge. (See figure VI.2 below, illustrating the procedure.) The length and angle of the straight edge result in the upper end being placed at 1,243 mm from ground level. The use of a 40° angle provides an objective means to delineate the grille/bumper from the hood. Moving along the width of the front-end and while

holding the straight edge parallel to the vehicle x-z plane, the contact points between the straight edge and the vehicle define the line. The reference to a 1,000 mm long straight edge is in the GTR. Our understanding is the 1,000 mm length of the straight edge was chosen for convenience, and may be a result of previous pedestrian test protocols.<sup>88</sup>

<sup>88</sup> We will discuss later below how, for a subset of vehicles, the straight edge length affects the front hood border.

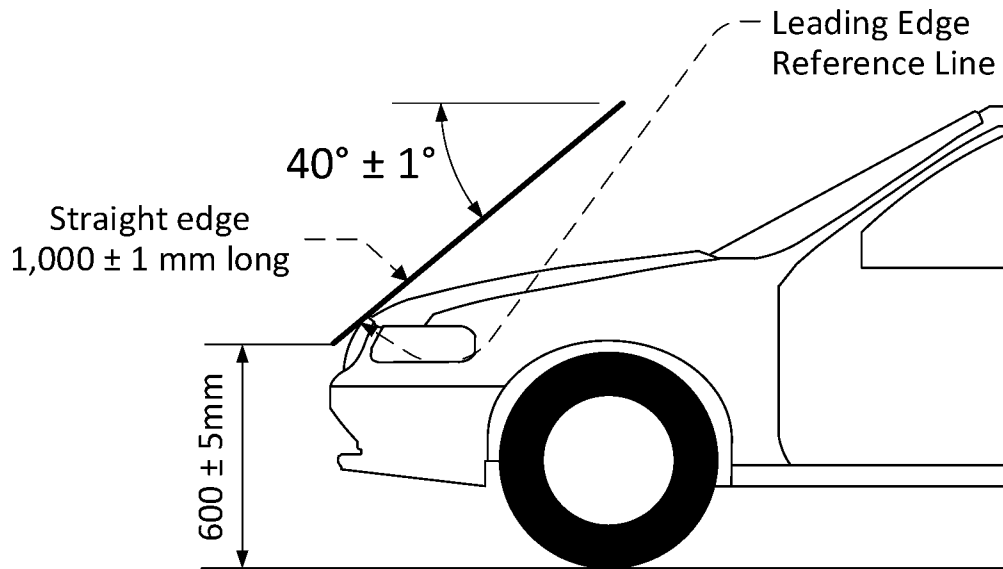

**Figure VI.2. Leading Edge Reference Line.**  
For illustration purposes only.

## 2. Side Borders of the Hood Top

The side borders of the Hood Top would be determined by identifying the Side Reference Lines (SRLs). An SRL would be drawn by running a straight edge angled at  $45^\circ$  along the side of the vehicle. Unlike in the procedure

establishing the LERL, the straight edge is not held a fixed distance from the ground when determining the SRL. The  $45^\circ$  angle provides an objective means to delineate the fender from the hood. Moving along the length of the vehicle, the contact points between the straight edge and the vehicle define the SRL.

The side border has been defined this way in all previous test protocols preceding the GTR, including those of the EEVC, IHRA, ISO, and NHTSA's earlier work on a pedestrian protection standard. It is also used in Euro NCAP. (See figure VI.3, provided for illustration purposes.)

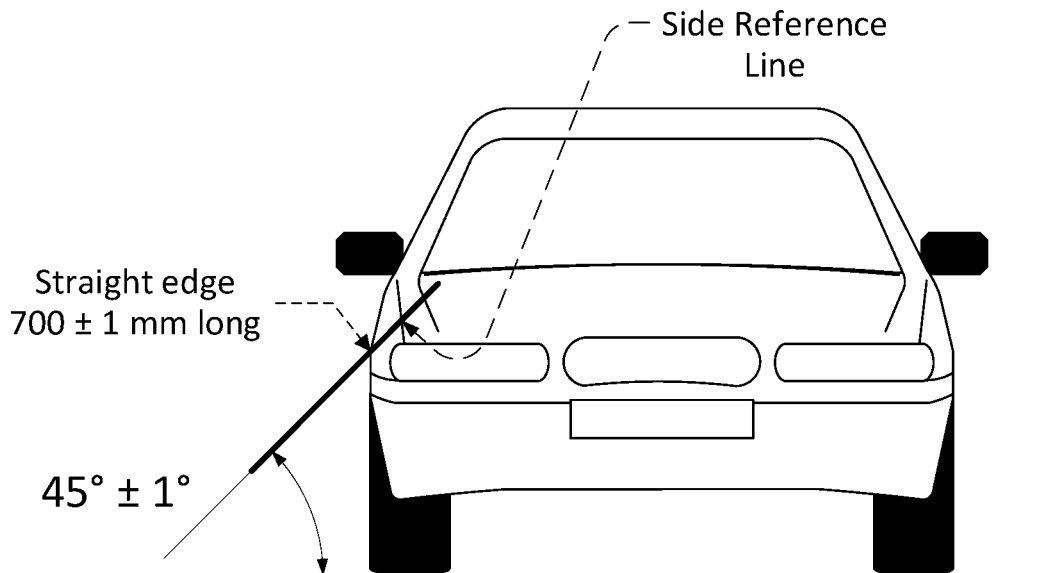

**Figure VI.3. Defining the Side Reference Line.**  
For illustration purposes only.

### 3. Rear Border of the Hood Top

The rear border of the Hood Top would be determined by identifying the Rear Reference Line (RRL). The RRL would be determined by inserting a 165

mm sphere into the cowl<sup>89</sup> and against the windshield such that the sphere is in contact with the windshield and a point on the surface of the hood (usually its rear edge). The RRL is formed by moving the sphere along the width of

the windshield while always keeping the sphere in contact with the windshield and the hood. The contact points between the sphere and the hood define the RRL. (See figure VI.4, provided for illustration purposes.)

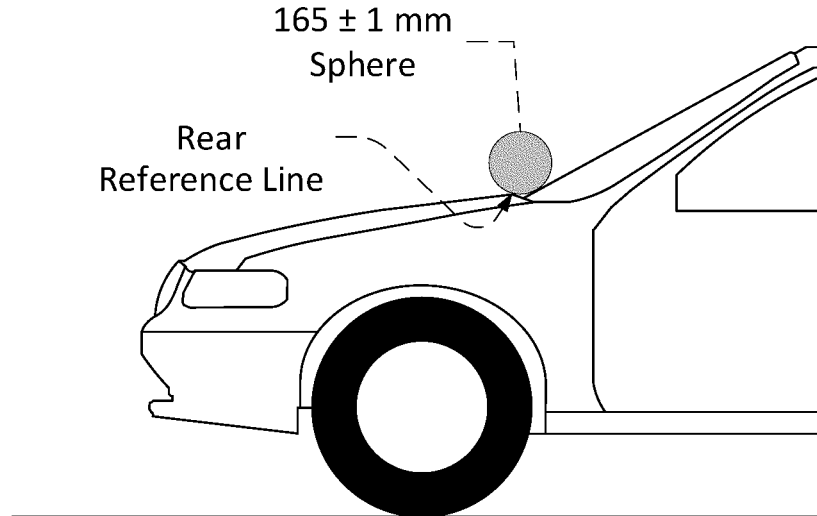

**Figure VI.4. Rear Reference Line.**  
For illustration purposes only.

#### BILLING CODE 4910-59-C

### 4. Provisions for Front Corners

The GTR is at times ambiguous regarding where to pinpoint the intersection of the Leading Edge Reference Line (LERL) and the Side Reference Line (SRL) defining the Hood

Top. The front border of the Hood Top is defined by the LERL. On vehicles that were on the road fifteen or more years ago, the hood front border did not have a high degree of curvature, and the point of intersection with the side border was easy to discern. However, on newer

models, the LERL is usually curved and often not smooth—such that it may be possible for the side border to intersect in more than one place (although we expect such occurrences to be rare). This is depicted in the figure below (figure VI.5).

<sup>89</sup>The cowl is the lower edge of the windshield opening. The wiper blades, linkages, and arms are removed during this process defining the RRL.

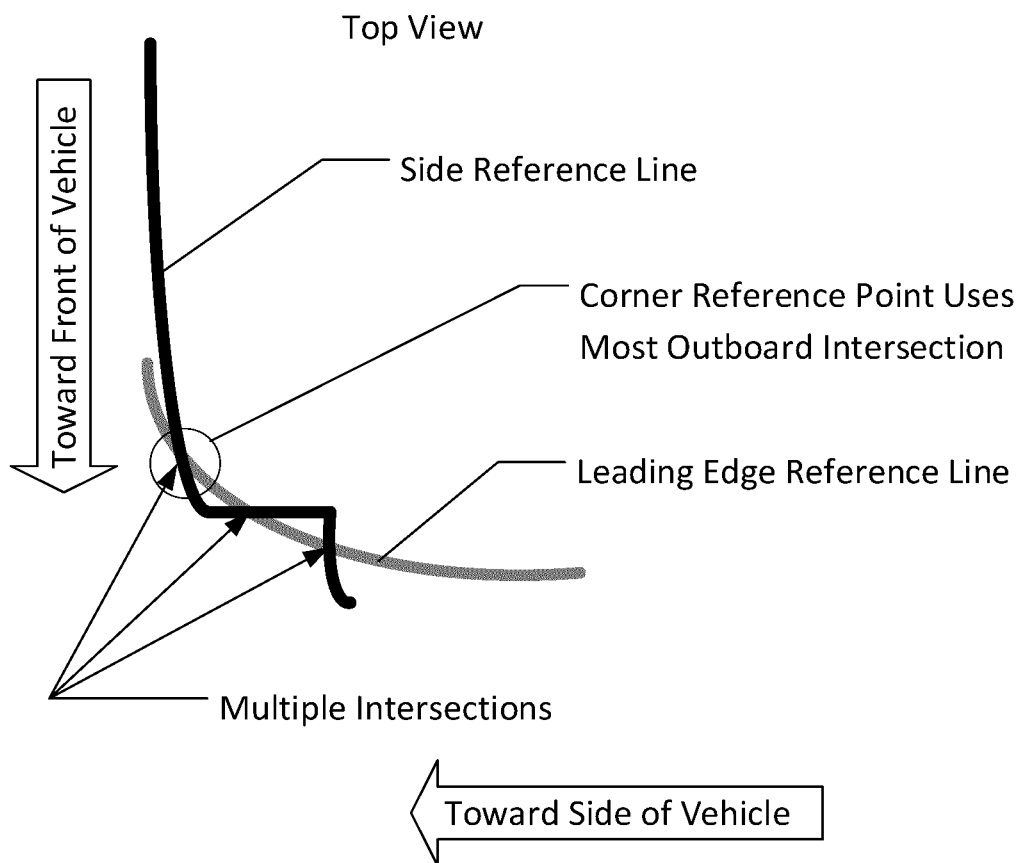

**Figure VI.5. Illustration of a Corner Reference Point of the Hood Area when multiple intersections of the Leading Edge Reference Line or WAD1000 Line and Side Edge Reference Line occur.**

To identify the boundaries for the Hood Top, it is important for NHTSA to know where the LERL intersects the SRL. In European test protocols used today (e.g., Euro NCAP V7.0 and later versions, UNECE Reg. No. 127), a “Corner Reference Point” for the Hood Top is defined to clarify this situation (shown graphically in figure VI.5). In those test protocols, the Corner Reference Point is the intersection of the LERL and the SRL. Additionally, Euro NCAP clarifies that if there are multiple intersections, the most outboard intersection comprises the Corner Reference Point.<sup>90</sup> We have included a definition of “Corner Reference Point” in our proposal for the same purpose, which would make clear that the Corner Reference Point of the Hood Top is the most outboard intersection when the LERL and the SRL intersect at multiple points.

As we discuss below, there are other areas defined on the vehicle hood that may also have multiple intersections at the front corners. To be clear in the

proposed standard as to how the areas are determined, we are also similarly defining the “Corner Reference Point of the Child Headform Test Area” and the “Corner Reference Point of the Hood Area.”

Finally, as mentioned previously, there is a proposed provision for determining the LERL of a high front vehicle when the tip of the straight edge makes first contact with the vehicle as opposed to elsewhere on the straight edge (see figure VI.16 later in the document). In such an instance, consistent with GTR 9, the WAD1000 line becomes the LERL. However, when this procedure is followed, it is likely that the WAD1000 line and SRL would not intersect due to their height difference, and thus, using procedures that would apply to vehicles of lower front ends, the Corner Reference Point of the Hood Top cannot be determined. To correct this deficiency, proposed FMVSS No. 228 would provide a procedure to connect the SRL to the WAD1000 line and thus establish the

Corner Reference Point of the Hood Top. This procedure involves establishing the Corner Reference Point of the Hood Top as if the LERL were determined by contact with the straight edge. The SRL and the WAD1000 line are then connected by a line spanning the distance from the Corner Reference Point of the Hood Top and the WAD1000 line.

#### 5. Provisions for Rear Corners

When the sphere and cowl procedure is conducted, often the RRL does not intersect the SRL, *i.e.*, the edges of the lines do not meet at the corners. Because it is important to defining the test area that the hood borderline be continuous, proposed FMVSS No. 228 provides an objective way to connect these two lines using a procedure in GTR 9.<sup>91</sup> FMVSS No. 228 would specify that the RRL is extended using a semi-circular template of radius  $100 \pm 1$  mm, marked with four reference marks “A” through “D,” as shown in figure VI.6.

<sup>90</sup> GTR 9 does not define a Corner Reference Point and makes no provision of multiple intersections between the LERL and SRL.

<sup>91</sup> GTR 9, section 3.6, p. 38.

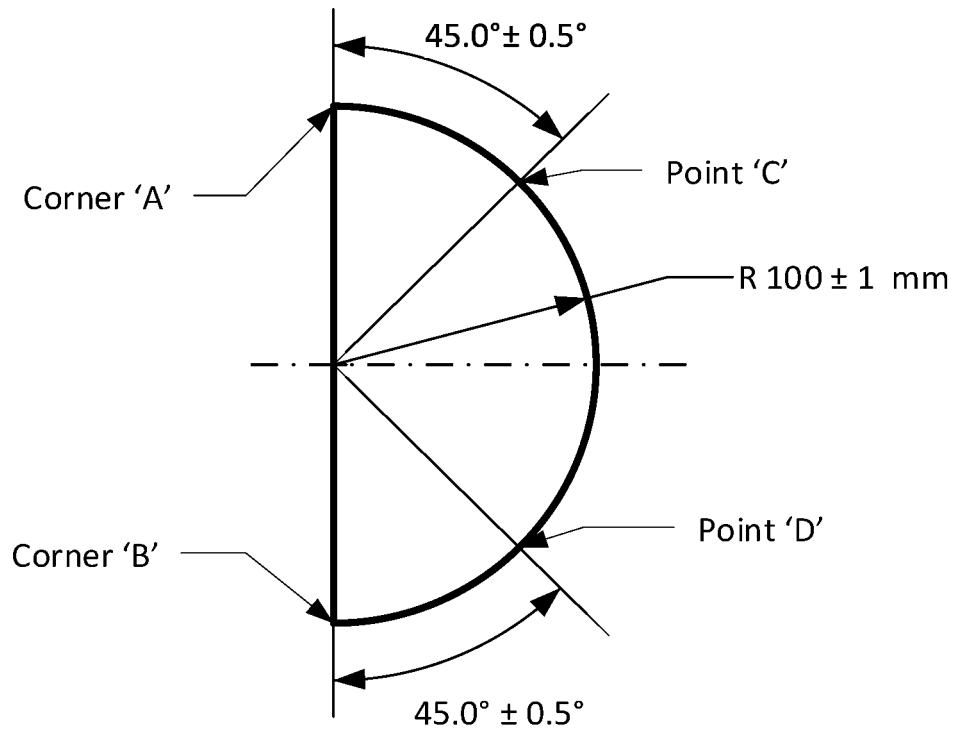
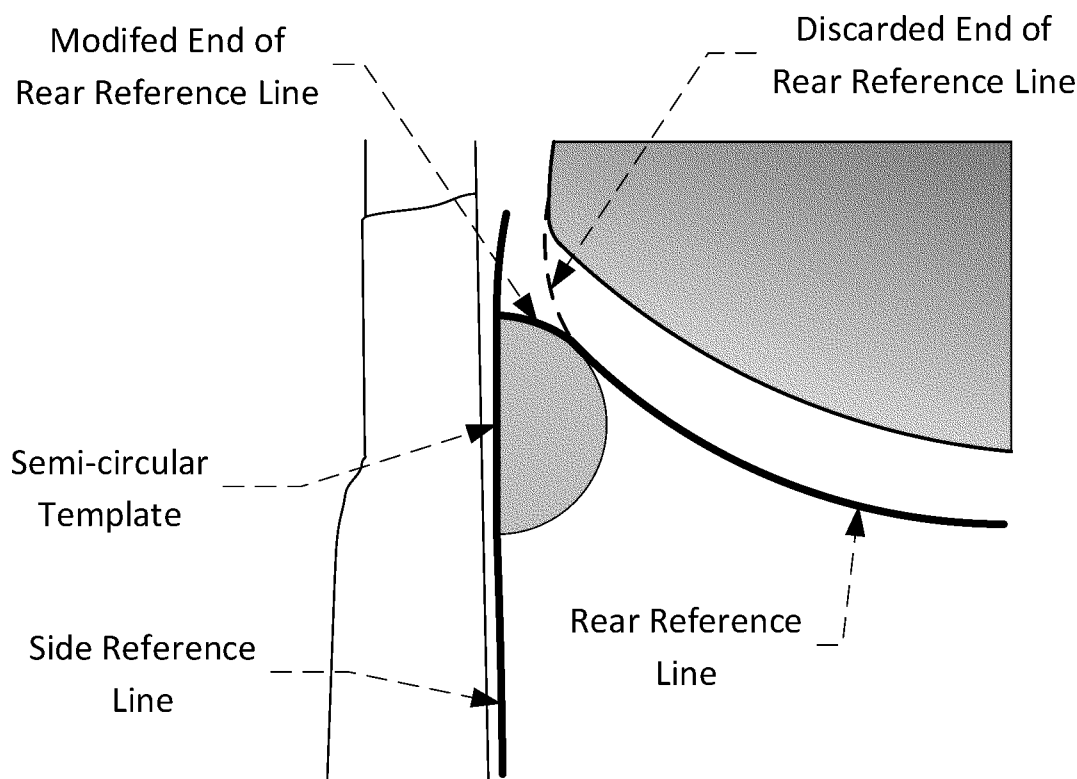

**Figure VI.6. Template used to revise a non-intersecting rear reference line.**

The template would be placed on the vehicle with corners "A" and "B" coincident with the side reference line. With these two corners remaining coincident with the side reference line, the template would be slid gradually

rearwards until the outer edge of the template makes first contact with the RRL. If the first point of contact between the template and RRL lies outside the arc identified by points "C" and "D," the RRL is extended and/or modified to

follow the circumferential arc of the template to meet the SRL, as shown in figure VI.7 (provided for illustration purposes).



**Figure VI.7. Marking of intersection between rear and side reference lines.**

If the outer edge of the template shown in figure VI.6 cannot contact the rear reference line while simultaneously contacting the side reference line at points “A” and “B,” or the point at which the rear reference line and template make first contact lies within the arc identified by points “C” and “D,” then the standard prescribes that larger templates must be used where the radii are increased progressively in increments of 20 mm, until all the criteria above are met.

#### 6. Clarifying the Borders

Through years of researching pedestrian head protection using the procedures described in the GTR, NHTSA has seen instances where the GTR is silent or ambiguous about its application to some aspects of hood design. NHTSA has developed ways to address these challenges consistent with

the GTR and NHTSA’s Safety Act requirements such that the FMVSS set forth objective and repeatable criteria. We propose to incorporate these lessons learned into FMVSS No. 228’s test procedures and criteria, some of which are highlighted below.

##### a. Addressing Discontinuities and Abrupt Direction Changes When Scribing the Side Reference Lines

In marking off the SRL using the straight edge, a contour on the hood or fender could create a continuous line with sudden changes in direction, or zigzagging in what was previously a relatively smooth line. NHTSA considers this marked-off side border a valid SRL and would not smooth out the line in a compliance test as may be customary in the European approval process.<sup>92</sup>

Yet, some vehicle contours may result in a discontinuous line (a line with a break in it). In other words, a “jump” could occur such that the border is no longer continuous because the points contacted by the straight edge alternated between portions of the vehicle surface separated by some distance. See figure VI.8 below, which depicts a hypothetical vehicle with a discontinuous SRL (discontinuity is not to scale). As shown in the figure, in this situation, NHTSA would “fill in” the gap and make the broken line whole again using a procedure that involves holding a non-stretch wire taut across the gap in the line. The break is filled by scribing a line created by the projection of the wire vertically downward on the vehicle surface. This procedure also results in a zigzagging final line, which is an acceptable outcome.

<sup>92</sup> Pedestrian Protection—ACEA Interpretations to the Respective Legislation of the UNECE and the European Union, revised November 30, 2010, Brussels. This document provides supplemental

definitions to several test procedures of GTR 9 that ACEA considered to be ambiguous. ACEA is the European Automobile Manufacturers Association, a group representing European-based automobile

manufacturers. <https://www.acea.auto/acea-members/>.

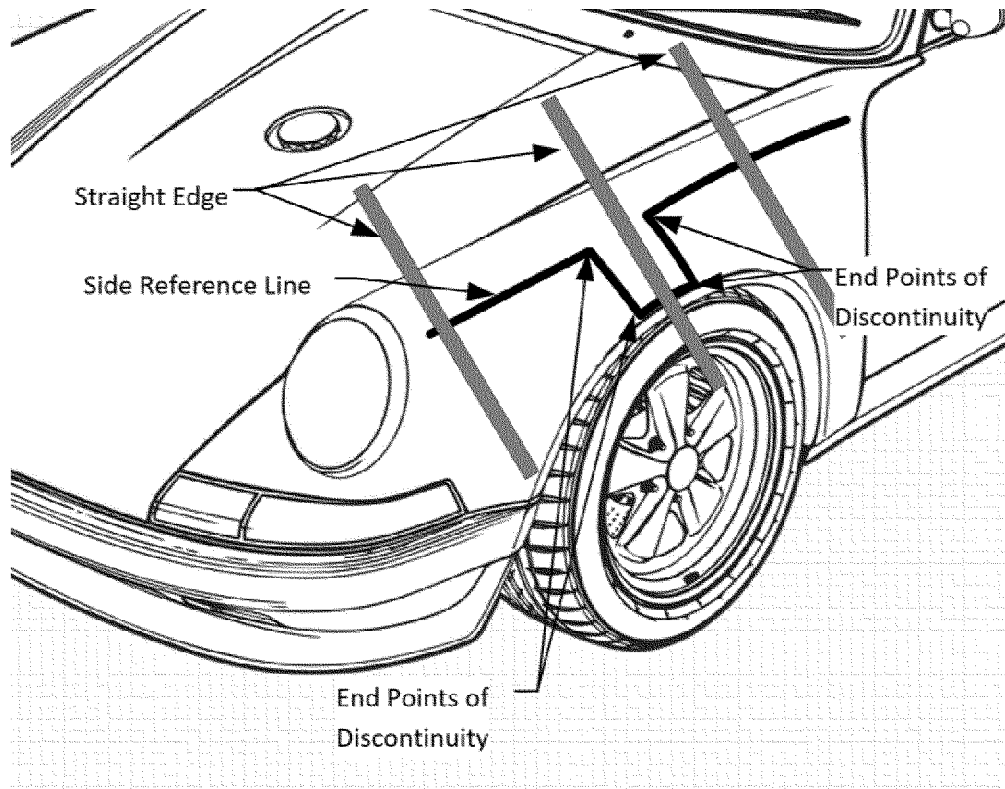

**Figure VI.8. Illustration of a Side Reference Line where a line break has been connected. The final result is a zigzag line.**

b. Multiple Contact Points

NHTSA has also encountered situations using the straight edge where the vehicle may be contoured such that the straight edge contacts two points at once (see figure VI.9). Such a situation could occur when scribing any of the hood borders. To address this, where multiple or continuous contacts occur NHTSA would use the contact that provides the largest Hood Top (*i.e.*, the

most outboard contact point for the side boundary, forward-most for the front boundary, and rearward-most for the rear boundary). This convention is also specified in Euro NCAP and the NCAP RFC for side borders. (We note that, as discussed in the next section, the procedure for scribing the Leading Edge Reference Line (LERL) uses a different strategy as a first step to avoid multiple contact points when scribing the line. The convention described above would

be used if multiple contact points occur even after using that initial step.) We note that GTR 9 specified the “highest points of contact” with the 700 mm straight edge when tracing the side reference line. In the example in figure VI.9, this would actually result in a more inboard point defining the SRL. However, in practice this is unlikely to result in any meaningful difference in the defined Hood Top.

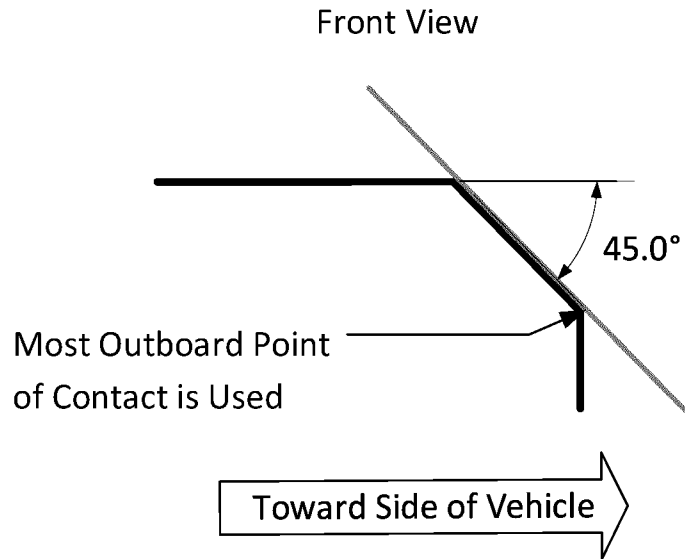

**Figure VI.9. Illustration of multiple contact points on vehicle side and most outboard point of contact.**

#### 7. Special Provisions for the Leading Edge of the Hood

As explained earlier, NHTSA uses a straight edge to define the LERL of the hood. Similar to the side border, this front border of the hood may have multiple points of contact when using the straight edge held at 40° from the horizontal. If continuous or multiple points of contact result, this NPRM (consistent with the GTR) specifies

adjusting the angle of the straight edge from 40° to 50° from the horizontal to try to achieve a single point of contact.<sup>93 94</sup> See figure VI.10 below, provided for illustration purposes. (This also has the effect of extending the LERL forward and thus increasing the headform test area, which NHTSA believes is desirable and consistent with safety.) We note that NHTSA is also proposing objective ways to determine whether there is “continuous contact”

or “multiple contact points” for assessing if the straight edge angle must change. Such a provision is not specified in GTR 9. A continuous contact would be established when the vehicle surface is within 0.5 mm of the straight edge for at least 50 mm of the straight edge. Contacts would have to be separated by at least 50 mm on the straight edge to be considered multiple contacts.

<sup>93</sup> Paragraph 3.5. “Bonnet leading edge reference line.”

<sup>94</sup> If this happens, the whole leading edge mark-off process is restarted using the 50° incline for the

entire leading edge, even though the discrepancy may have occurred at only one spot.



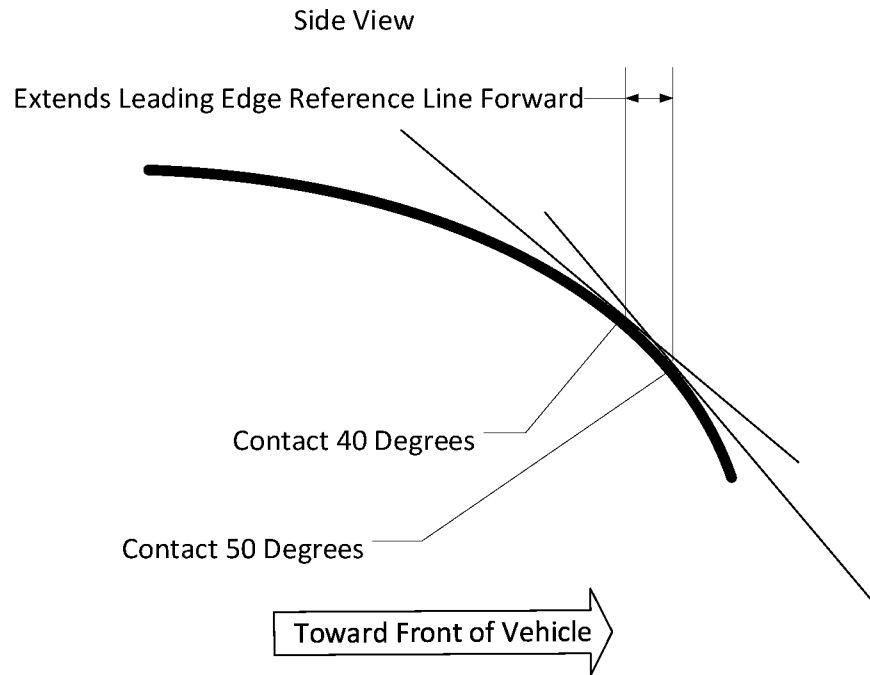

**Figure VI.10. Straight edge angle change when scribing Leading Edge Reference Line if multiple or continuous contact occurs.**

As is the case with the Side Reference Lines, a zigzagging final front border is an acceptable result. If there are gaps in the line, NHTSA would fill in the gaps using a non-stretch wire held taut across the gap in the line. The break is filled by scribing a line created by the projection of the wire vertically downward on the vehicle surface. Any protruding hood ornaments would be removed when drawing the LERL if they have the effect of pushing the border rearward (and reducing the test area).

One additional special provision of the LERL relates to vehicles where the only contact of the straight edge is at its upper tip. Consistent with the GTR, as the straight edge is moved laterally across the front of the vehicle, if the upper tip is the only contact point, the WAD1000 line is the LERL at this location. Additional discussion on this topic is presented later in this document.

#### *B. Hood Area*

After identifying the Hood Top, the next step is to establish the "Hood

Area."<sup>95</sup> The Hood Area (see light grey area in figure VI.11) is enclosed by the intersection of the following borders:

- *Front border:* the Leading Edge Reference Line (LERL) or the WAD1000 line, whichever is most rearward at the point of measurement;
- *Side border:* Side Reference Lines (SRL).
- *Rear border:* Rear Reference Line (RRL), or the WAD2100 line, whichever is most forward at the point of measurement.

**BILLING CODE 4910-59-P**

<sup>95</sup> For some vehicles, the Hood Area may be equivalent to the Hood Top. Also, we note that GTR

9 does not define a Hood Area. In GTR 9, the equivalent area would be what GTR 9 refers to the

"combined child and adult headform test areas." We have defined Hood Area for increased clarity.

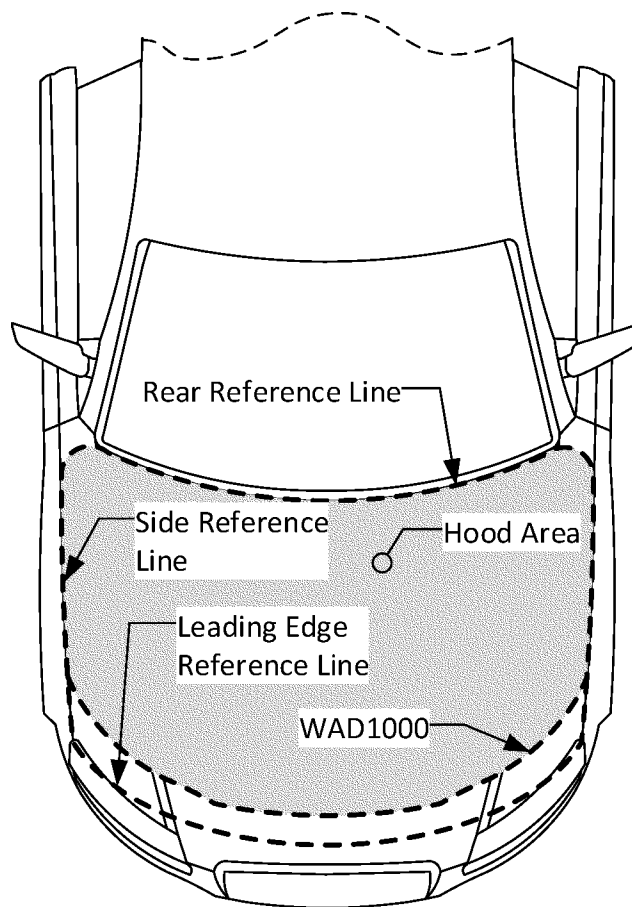

**Figure VI.11. Example Hood Area outline.  
For illustration purposes only.**

**BILLING CODE 4910-59-C**

**1. Front Border of the Hood Area**

Consistent with GTR 9, this NPRM proposes to use the most rearward of either the WAD1000 line or the LERL in determining the front border of what proposed FMVSS No. 228 would call the Hood Area. In the example shown in figure VI.11 the Hood Area (light grey) does not completely cover the Hood Top because the WAD1000 line is rearward of the LERL. The cross hatched area shows the difference between the Hood Top and Hood Area. WAD1000 is just under the average height of a 6-year-old child (a target demographic of the standard), which is 1,150 mm. The drafters of the GTR explained that a WAD of 1,000 mm was selected as the forward boundary because real-world crash data show that over 80 percent of child pedestrian head contacts are above a WAD of 1,000 mm.<sup>96</sup> Figure VI.11, above, shows an example of the

WAD1000 line defining the front edge of the Hood Area, rather than the LERL. As we discuss in section VI.C.1, the front border of the Hood Area could be the front border of the Child Headform Test Area on some vehicles. We also discuss how we are considering shifting the front border of the Child Headform Test Area to increase the area subject to the proposed standard. (Conforming changes would be reflected in the front border of the Hood Area if such a change were made.)

**2. Side Border of the Hood Area**

The side borders for the Hood Area are the SRLs, which are also the side borders for the Hood Top. The length of side borders may differ from the Hood Top on some vehicles since the Hood Area may have different rear and front borders than those of the Hood Top.

**3. Rear Border of the Hood Area**

Similar to the process for the front border, the first step in establishing the rear border of the Hood Area is to locate the WAD2100 line (WAD2100). This NPRM's regulatory text proposes to use

the most forward of either WAD2100 or the Rear Reference Line (RRL)<sup>97</sup> in determining the rear border of the Hood Area. Strictly speaking, this is different from GTR 9, which defines the rear boundary of the equivalent area (rear reference line for the adult headform) as always being WAD2100. We believe this is an error in GTR 9, because under this reading of the GTR, even if the RRL were forward of the WAD2100 and WAD2100 is in the windshield area (essentially off of the Hood Top), WAD2100 still would be used as the rear border of the area in question. This would affect the calculation of the amount of area that must conform to a HIC1000 level, potentially including part of the windshield or cowl. This outcome is not consistent with our understanding of GTR 9.

This NPRM's regulatory text describes using the most forward of either

<sup>97</sup> As a reminder, the RRL is determined by inserting a 165 mm sphere into the cowl and against the windshield such that the sphere is in contact with the windshield and a point on the surface of the hood (usually the cowl's rear edge).

<sup>96</sup> Paragraph 72 of the "Safety Need" section of GTR 9. <https://unece.org/fileadmin/DAM/trans/main/wp29/wp29wgs/wp29gen/wp29registry/ECE-TRANS-180a9e.pdf>.

WAD2100 or the RRL in determining the rear border of the Hood Area. For most passenger cars, WAD2100 falls rearward of the cowl so the rear border would be the RRL. However, WAD2100 could define the rear border on some larger vehicles. Figure VI.12, below, shows an example of the WAD2100 line

defining the rear edge of the Hood Area, rather than the RRL. Again, the cross hatched area shows the difference between the Hood Top and Hood Area. As we discuss below, the rear border of the Hood Area may not necessarily be the rear border of the Adult Headform Test Area. In section VI.C.5, we discuss

using WAD2500 rather than WAD2100 as the rear reference line for the Adult Headform Test Area. (Conforming changes would be reflected in the rear border of the Hood Area if such a change were made.)

BILLING CODE 4910-59-P

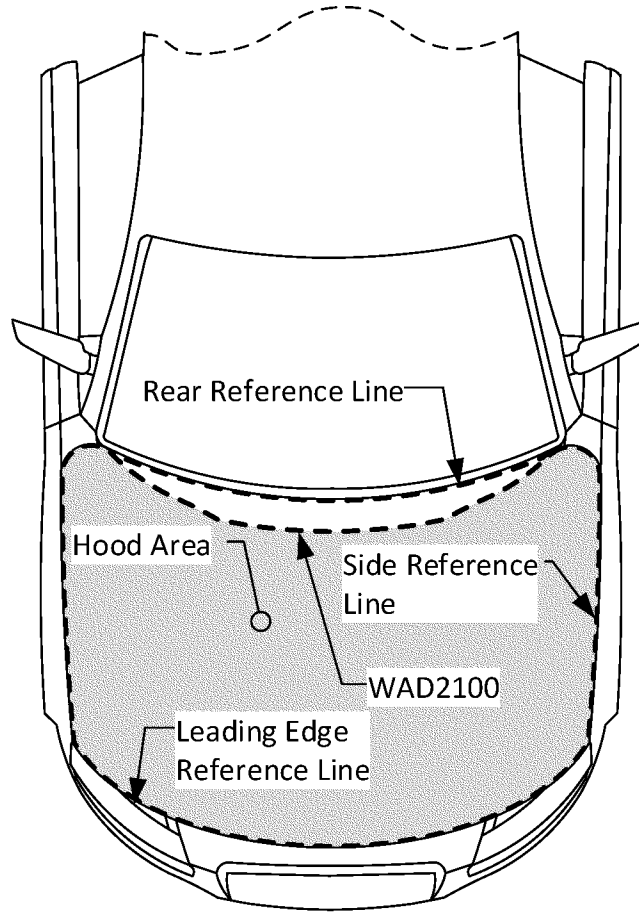

**Figure VI.12. Example Hood Area outline.**  
For illustration purposes only.

BILLING CODE 4910-59-C

#### 4. Corner Reference Point of the Hood Area

As was the case with the Hood Top, we believe it is also necessary to define a Corner Reference Point for the Hood Area to avoid any ambiguity in pinpointing the intersection of the front and side borders of the Hood Area. Obviously, when the Hood Top and Hood Area share the same front border (LERL), the corner point is the same. However, when the front border of the Hood Area is the WAD1000 line, the corner points will be different, with the Corner Reference Point of the Hood Area being at the intersection of the WAD1000 line and the side border, and

the Corner Reference Point of the Hood Top being at the intersection of the LERL and the side border.

#### C. Defining the Child Headform Test Area and the Adult Headform Test Area

*Overview.* Proposed FMVSS No. 228 defines a Child Headform Test Area and an Adult Headform Test Area, which are contained within the Hood Area.<sup>98</sup> Consistent with GTR 9, under this NPRM the test areas have been separated into child and adult regions because head strikes on the hood in

<sup>98</sup> As noted earlier, this preamble occasionally refers to these two test areas together as the “Child and Adult Headform Test Areas” or “the combined Child and Adult Headform Test Areas.”

real-world collisions are dependent primarily on the collision speed, the height of the pedestrian, and the shape of the vehicle front-end.<sup>99</sup> WAD is used for demarcation of the Child and Adult Headform Test Areas because it is an excellent indicator of where a pedestrian’s head will strike a hood under a given set of conditions.<sup>100</sup>

<sup>99</sup> Ivarsson BJ, Crandall JR et al (2007). Pedestrian head impact- what determines the likelihood and wrap around distance? Paper No. 07-0373, 20th International Technical Conference on the Enhanced Safety of Vehicles Conference (ESV) in Lyon, France, June 18–21, 2007.

<sup>100</sup> The crash scenario represented by the test is a non-braking, 40 km/h impact. The suspension is set up for normal ride attitude, not braking.

### Headform HIC Unlimited Areas

The Child and Adult Headform Test Areas are smaller than the Hood Area to account for specified regions that are not subject to HIC limits under the GTR, which we call “HIC Unlimited Area.”<sup>101</sup> The HIC Unlimited Area shares an outer boundary with the Hood Top. Its inner boundary is called the HIC Unlimited Margin. The HIC Unlimited Margin forms the outer

boundary of the Child and Adult Headform Test Areas.

The Child Headform Test Area (See figure VI.13) is enclosed by the intersection of the following borders:

- *Front border:* HIC Unlimited Margin of the Leading Edge Reference Line.<sup>102</sup>
- *Side borders:* HIC Unlimited Margins of the Side Reference Lines.
- *Rear border:* WAD1700 line or the HIC Unlimited Margin of the Rear

Reference Line, whichever is most forward at the point of measurement.

The Adult Headform Test Area (See figure VI.13) is enclosed by the intersection of the following borders:

- *Front border:* WAD1700 line.
- *Side borders:* HIC Unlimited Margins of the Side Reference Lines.
- *Rear border:* HIC Unlimited Margin of the Rear Reference Line.<sup>103</sup>

BILLING CODE 4910-59-P

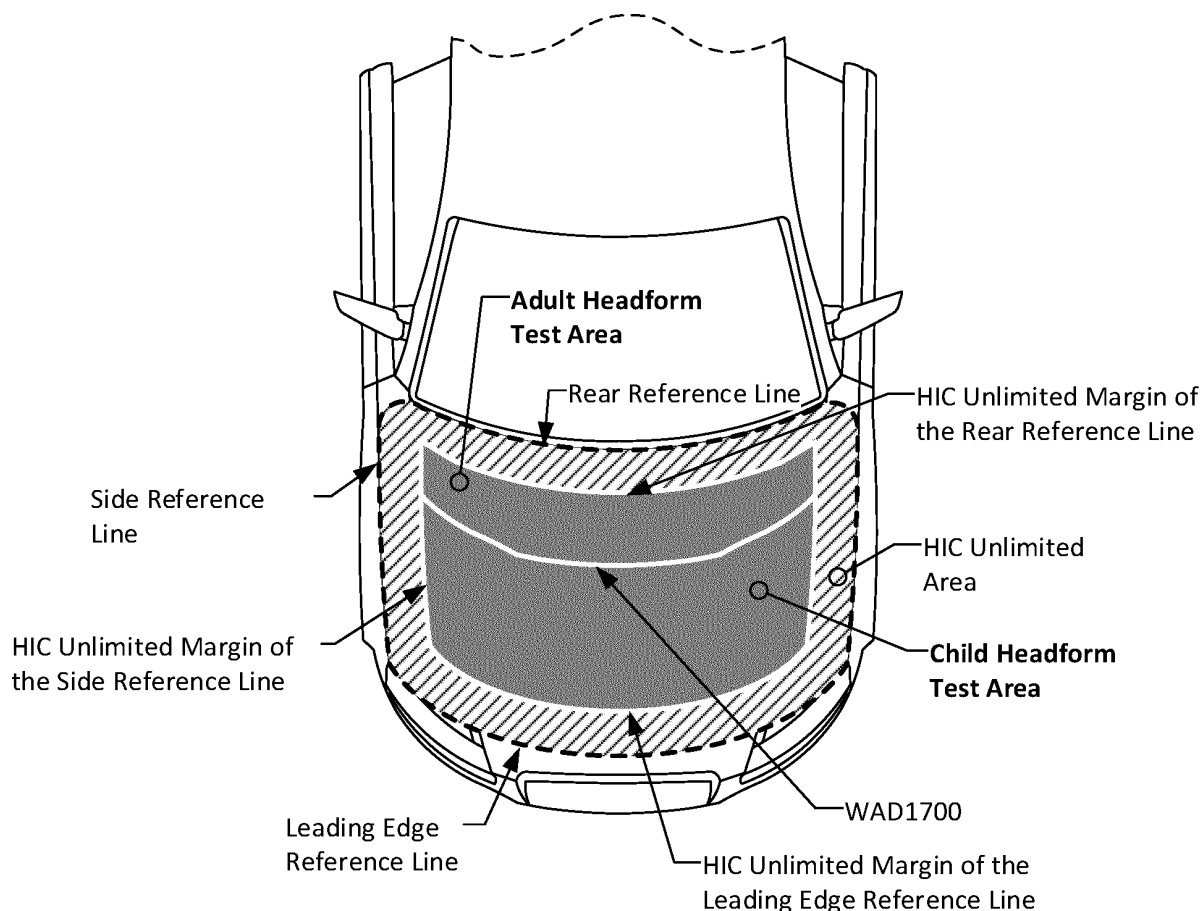

**Figure VI.13. Example Child and Adult Headform Test Area outline.  
For illustration purposes only.**

#### BILLING CODE 4910-59-C

The first step in determining the HIC Unlimited Margin would be to establish a reference line by measuring an 82.5 mm (3.25 inches) distance from each point along the four borders of the Hood Top. For convenience, in this preamble we refer to this as “the 82.5 mm offset line.” (See figure VI.14.) For example, the HIC Unlimited Margin of the Side Reference Line is established by

following the SRL along the contour of the body in the y-z plane using the equivalent of a taut, 82.5 mm (3.25 inch) graduated wire. The regulatory text describes using the wire to measure the 82.5 mm (3.25 inches) distance over any surface bumps that may be present, such as ornamental trim. Since the wire is taut, it would span any depressions (such as a seam between the hood and fender) between the points on the SRL

to the measured points. The wire must not deviate from the y-z plane when establishing the HIC Unlimited Margin of the Side Reference Line. Similarly, an 82.5 mm offset line for the LERL and RRL would be drawn by measuring the prescribed distance from each point along the LERL and RRL along the contour of the body in the x-z plane using a taut, graduated wire.

<sup>101</sup> As explained previously, the standard would provide for HIC Unlimited Areas as a practicability measure to accommodate a manufacturing need to reinforce and stiffen the hood edges.

<sup>102</sup> As explained later in this section, this is either the 82.5 mm offset line or the WAD1000 line, whichever is more rearward.

<sup>103</sup> As explained later in this section, this is either the 82.5 mm offset line or the WAD2100 line, whichever is more forward.

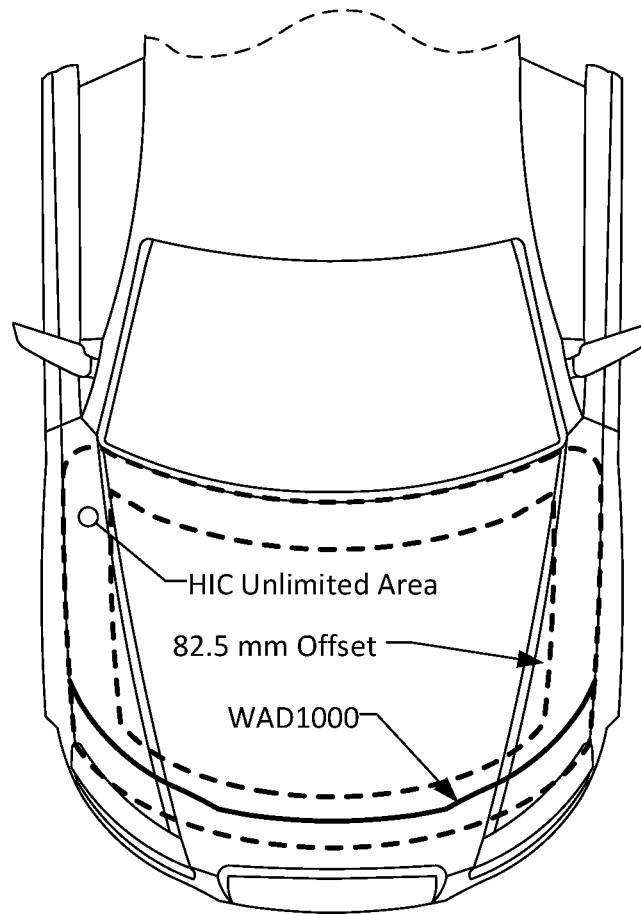

**Figure VI.14. Example of Establishing 82.5 mm Offset line. In this example, the WAD1000 is forward of the 82.5 mm Offset line. Not to scale. For illustration purposes only.**

**1. Front Border of Child Headform Test Area**

The front border of the Child Headform Test Area is the HIC Unlimited Margin of the Leading Edge Reference Line, which is the WAD1000 line or the 82.5mm offset line, whichever is most rearward.<sup>104</sup> Figure VI.15 shows an example where the front border of the Child Headform Test Area

(right image) is formed by the 82.5 mm offset line and the front border of the Hood Area is the WAD1000 line (left image). As in figure VI.12, the left image shows the Hood Area overlaid on the Hood Top (cross hatch showing the difference), with the Hood Area being smaller because WAD1000 is rearward of the LERL. In the right image we see that the test area begins rearward of the

Hood Area front border. The left image shows the borders of the Hood Area (light grey area) and the right image the border of the Child and Adult Headform Test Areas (dark grey). Note that in the right image any area that is not part of the Child and Adult Headform Test Areas is part of the HIC Unlimited area (this includes the light grey and the cross hatched areas).

<sup>104</sup>Note that the front border of the Child Headform Test Area is the most forward border of the combined test area.

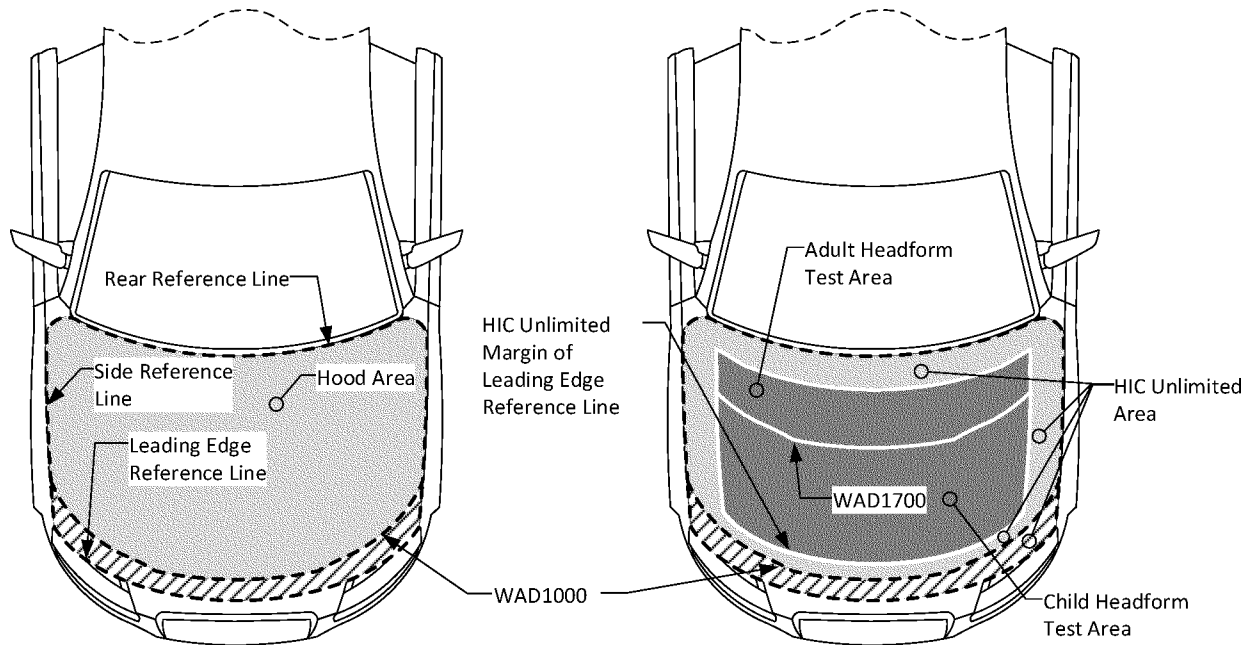

**Figure VI.15. Left image shows an example of the Hood Area overlaid on the Hood Top. Right image shows the Test Area overlaid on the Hood Area. For illustration purposes only. Not to scale.**

#### c. Considerations for the Child Headform Test Area Front Border

The agency believes there are several provisions where it would be worthwhile for FMVSS No. 228 to differ from GTR 9 with respect to the front border of the testable area, particularly for vehicles that are larger or smaller than typical size. NHTSA requests comment on these approaches for possible inclusion in the final rule.

First, with respect to large vehicles, this NPRM's regulatory text for FMVSS No. 228 reflects the provisions of GTR 9 regarding the procedures for testing vehicles with higher front ends, like larger light trucks, but the agency discusses in this section aspects that NHTSA believes may be more

appropriate for the U.S. fleet. To begin, the GTR procedure is as follows: When establishing the front border of the relevant Hood Top, Hood Area, and ultimately the Child Headform Test Area, the first step is to use the 1,000 mm straight edge to determine the LERL. As shown in figure VI.16, for passenger car designs, the straight edge is held high enough to engage the vehicle's front end. However, the upper leading edge of the hood for some full-sized pickup trucks exceeds 1,243 mm, which is the highest point of the straight edge from the ground. For these vehicles, the upper tip of the straight edge would be the only point of contact with the vehicle. If this occurs, consistent with S3.5 in GTR 9, by definition, the WAD1000 line becomes

the LERL. (This provision may also come into play for flat front EVs.) Thus, the front border of the Child Headform Test Area would be established by the 82.5 mm offset line from the WAD1000 line. In some vehicles this may be in the front grille area.

Large pickups and large SUV comprise about 18 percent of new vehicle sales, and some vehicles are large enough that they will engage the tip of the straight edge in this way, such as the MY 2022 Ford F250.<sup>105</sup> Given the prevalence of large vehicles in the U.S. fleet, we believe there are several points worthy of discussion related to this issue, and related to high or flat front vehicles in general. These are discussed below.

<sup>105</sup> 2021 Wards Automotive.

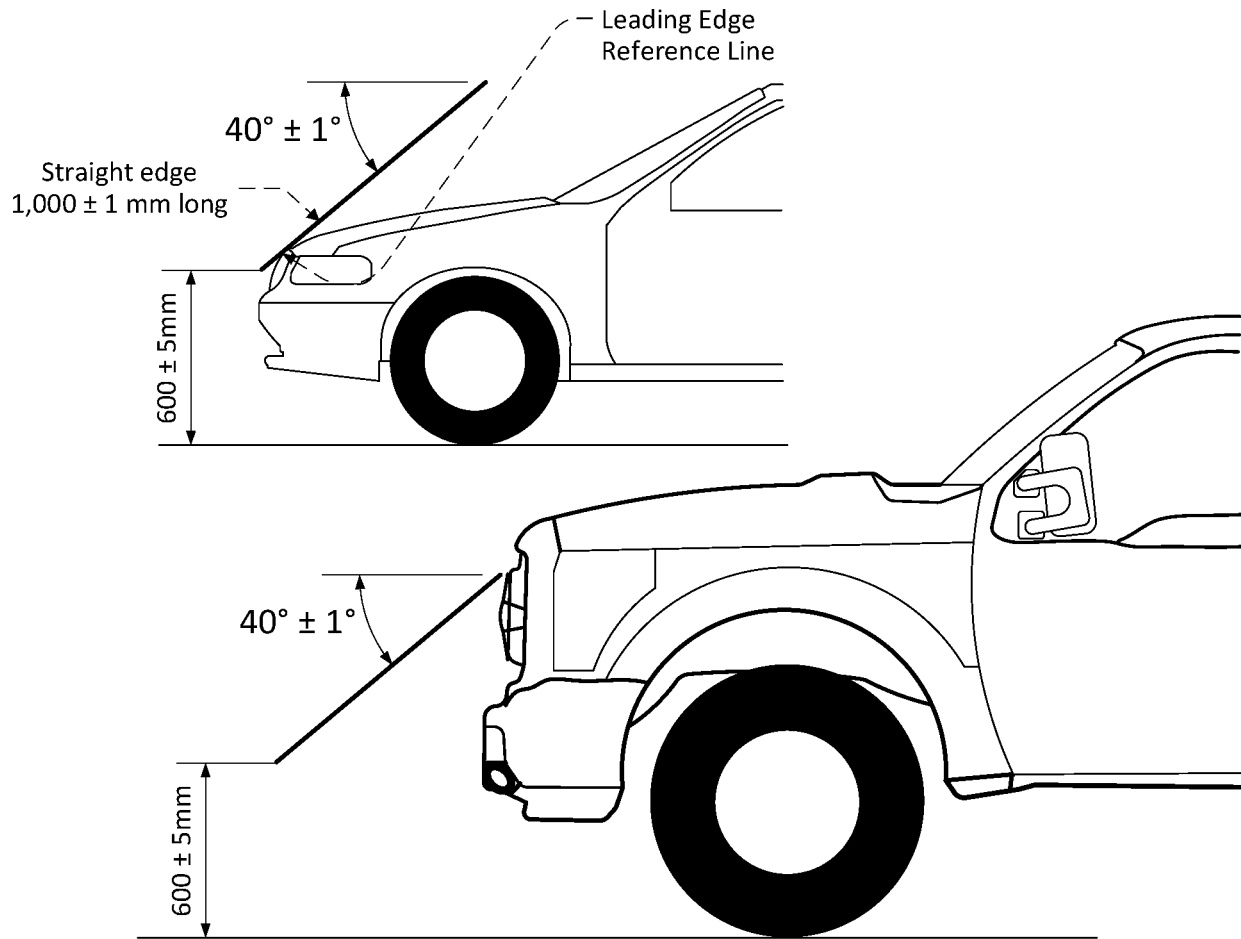

**Figure VI.16. Hood Marking of Passenger Car Compared to High Front Vehicle.  
For illustration purposes only.**

**i. Extending the Straight Edge**

First, it would clearly be possible as a practical matter to extend the straight edge to whatever length necessary to contact the vehicle at the more typical front hood location. However, this may result in loss of a significant amount of testable area in the grille and associated safety benefits. Child and small adult pedestrian heads are more apt to strike the grille than the hood top on these vehicles, so extending the straight edge would reduce the real-world relevance of the test as regards those pedestrian impacts. Therefore, the agency is not inclined to make such an accommodation without a demonstration that subjecting the grille to testing is infeasible, meeting the standard is impracticable, or other such reason. In a section below, we request comment on the practicability of meeting proposed FMVSS No. 228 in the grille area.

**ii. NHTSA Seeks a More Consistent Approach**

The provision establishing the WAD1000 line as the LERL if the tip contacts the vehicle sets up a provision in the standard that would test vehicles differently. In vehicles such as that shown in the bottom part of figure VI.16, the LERL would be WAD1000 because the tip of the straight edge contacts the vehicle—and, as a result, because WAD1000 is in the grille, the grille would be tested. However, for a vehicle with a slightly lower hood height that just allows the straight edge to make contact with the hood along the straight edge length and not at its tip, the LERL would not drop to the WAD1000 line in the grille area—and so the grille area would not be tested. NHTSA believes a more consistent and reasonable approach could be one that determines the test area using data tied to where head impacts are likely to occur, as opposed to an approach that

determines test area by the length of a straight edge. Thus, NHTSA requests comments on an approach that establishes the WAD1000 line as the front border of the test area for all vehicle testing. NHTSA believes this approach is merited as it determines the test area based on where head impacts would occur in the real world, rather than where a straight edge makes contact. The agency poses specific questions at the end of this section and requests comments on using this approach in the final rule.

**iii. Impact Angle Considerations**

We request comment on the specifics of testing a grille area. As described in the test procedure of the GTR, the child headform is launched at 50 degrees down from the horizontal and would impact a horizontal surface at 40 degrees from a purely perpendicular impact. (The child headform impact angle is illustrated in figure V.3 of this preamble.) Assuming, for simplicity, a vertical front face of a vehicle, this

means the impact would be 50 degrees from purely perpendicular. However, striking a grille in this manner would constitute a slightly less direct impact and presumably a less severe test. We believe that, in a real-world impact, the head of a child striking such a high front end vehicle would have a trajectory more in line with the velocity vector of the vehicle than the current launch angle of the child headform. The Euro NCAP procedure and NHTSA's NCAP RFC allow for test points on the front surface of the vehicle. Euro NCAP and the NCAP RFC make an adjustment to the impact direction to 20 degrees when forward of the LERL so as to produce a more perpendicular impact. Additionally, if the LERL is between WAD930 and WAD1000, Euro NCAP monitors this location with a 20-degree impact test performed at the LERL.<sup>106</sup> NHTSA plans to conduct research on headform testing in the grille area of some pickup trucks using the proposed FMVSS No. 228 protocol to assess its practicality, as well as the merits of a more direct (perpendicular) impact. As discussed in the next section, depending on the results, the final rule may adjust the impact angle of the headform when the test is conducted in the grille area.

iv. Apportioning of Test Area to HIC Levels

For these high front and flat front vehicles, the apportioning of the amount of the test areas that must have a HIC1000 or less merits discussion. As previously mentioned and discussed in more detail in section VII of this

preamble, the portion of the Combined Child and Adult Headform Test Areas that must meet the HIC1000 provision must be at least the numerical value of two-thirds of the Hood Area placed inside of the Child and Adult Headform Test Areas. Because this two-thirds calculation is made on the basis of a two-dimensional projection on to a horizontal plane, if some of the Child Headform Test Area could be on a front surface of a vehicle that is more vertical than horizontal, this area would not be added to the Hood Area calculation simply due to the method of calculation using the two-dimensional projection onto a horizontal plane. The concern here is that this vertical test area, even if considered part of the headform test area, would not be considered in calculating the amount of required HIC1000 area. Stated another way, the vertical test area, or an equivalent amount, would not have to meet HIC1000; it could be assigned only HIC1700, which would result in the vehicle providing a lowered level of head protection. (Comments are requested on this issue in the next section.)

v. Shifting the Test Border Forward

This point relates to large vehicles in general where the upper portion of the straight edge, but not the tip, makes contact with the vehicle. For these vehicles, WAD1000 could be in the grille area,<sup>107</sup> but under the GTR, the Child Headform Test Area begins well beyond WAD1000, because the test area would begin at the 82.5 mm offset line as it is more rearward than WAD1000.

NHTSA is concerned that, for such vehicles, under the GTR provisions the agency would not be testing the areas of the hood that could be struck by children of the stature of a 6-year-old. As mentioned above, the NCAP RFC procedure allows for testing to WAD1000, even when WAD1000 is forward of the LERL. In 2014, NHTSA investigated how the different interpretations of the impact point targeting methods could change the actual testable area of a hood.<sup>108</sup> Headform tests were performed along the forward-most border of the test zone and, depending on which targeting method was used, the actual point of first contact of the headform with the hood was either on the border or slightly in front of the border (see table VI.1). Although HIC was found to increase at first contact locations in front of the border, the increase did not appear to have affected conformance, *i.e.*, impact points conforming to either HIC1000 or HIC 1700 remained below the required HIC limit. Based on these results, NHTSA believes a requirement that vehicles meet FMVSS No. 228 with a 30 mm shift of the forward-most border seems practicable. We request comments on this issue. We note that in section VII and XI of this preamble, we also discuss the issue of whether proposed FMVSS No. 228 should reduce or eliminate the areas in which, under the GTR, HIC is not assessed (the HIC Unlimited Area). Reducing or eliminating the HIC Unlimited Area would also shift the forward-most border forward.

TABLE VI.1—HIC AT POINTS TESTED ON THE FORWARD-MOST BORDER AND AT A POINT SHIFTED SLIGHTLY AHEAD OF THE BORDER

Vehicle	HIC comparison		HIC % increase
	At forward-most border per GTR 9	At point shifted about 30 mm forward of border	
2010 Buick Lacrosse .....	1026	1041	1.5
2010 Kia Forte .....	626	703	12.3
2010 Acura MDX .....	1283	1326	3.4
2010 Hyundai Tucson .....	638	670	5.0
2011 Jeep Grand Cherokee .....	651	874	34.3
2011 Honda Odyssey .....	1302	1379	5.9

<sup>106</sup> Monitors means the results could be called out but are not part of the Euro NCAP scoring. See, Technical Bulletin 019—Headform to Bonnet Leading Edge. <https://www.euroncap.com/en/for-engineers/supporting-information/technical-bulletins/>. This bulletin explains that the result of this test will be monitored against a HIC value of 650. Where a “poor” test result has been achieved,

Euro NCAP may choose to comment on this alongside the normal pedestrian protection score. The results of these tests will not be reflected in the pedestrian protection score or any other part of the overall assessment.

<sup>107</sup> GTR data indicate that 6-year-old child head impacts start at about WAD1000.

<sup>108</sup> Details of these tests can be found in: Suntay B and Stammen, JA (August 2018), Vehicle hood testing to estimate pedestrian headform reproducibility, GTR 9 test procedural issues, and U.S. fleet performance. Docket NHTSA–2008–0145–0014.



vi. Testing Forward of WAD1000 for Small Vehicles

Regarding smaller vehicles, the NPRM's regulatory text reflecting the GTR specifies that the forward border of the required test area would be the 82.5 mm offset line or WAD1000, whichever is most rearward. Under this proposed provision, requirements for head protection would start at WAD1000 for most small vehicles as the WAD1000 line is usually more rearward than the 82.5 mm offset line. However, for many smaller vehicles WAD1000 is far up the hood, which means much of the hood (the forward portion) would not be subject to any headform testing. It does not appear there are practicability barriers to headform testing of the hood on small vehicles, because comparable areas of the hood on larger vehicles would be regulated under the proposed standard and thus subject to headform testing. Testing forward of WAD1000 would potentially add to the protection of children with a standing height of less than 1,000 mm. As discussed below, to increase the safety benefits of the rule, we are considering an alternative provision that would test forward of WAD1000. NHTSA requests comment on this issue.

Request for Comment on Modifying the Forward Border

Based on the above discussion, NHTSA requests comments on the questions below to help the agency decide whether a final rule should identify the forward border differently. Please comment on the potential gain in safety benefits as well as any potential practicability, cost, or technical issues.

- The NPRM's regulatory text reflects the GTR 9 provision that accounts for the situation where the tip of the 1,000 mm straight edge defines the LERL (rather than a point further down along the straight edge), such as when the tip of the straight edge could make first contact with the grille of a subject vehicle. In this situation, the WAD1000 line becomes the LERL. This means that the testable area could potentially include the grille area of the vehicle

(*i.e.*, headform impacts could be conducted on the grille area of the vehicle). We request comment on adjustments to the launch angle<sup>109</sup> for such impacts, to potentially make them more perpendicular to the impacted surface to replicate a real-world impact more accurately. What impact point condition/location should trigger a change in impactor launch angle? Additionally, should the estimate of Hood Area be modified if some portion of the Hood Top is in the grille area, such as using a test area projection onto a vertical plane for the more vertical tests areas?

- There may be large vehicles with a hood height slightly lower than those where the straight edge tip contacts the vehicle first, such that the provision to drop the LERL to WAD1000 is not triggered. Additionally, the NPRM's regulatory text (reflecting the GTR) specifies that, for large vehicles in general, the Child Headform Test Area begins well rearward of WAD1000—*i.e.*, well rearward of where a child's head is likely to strike. However, NHTSA requests comments on changing the front border of the Child Headform Test Area to be either the Offset Line or WAD1000, whichever is *forward-most*, rather than rearmost. An outcome of this change would be that, in some cases, the test area would be forward of the Hood Top and conforming changes would need to be made to maintain the test area within the Hood Top. We note that the Euro NCAP and the NCAP RFC allow for testing at WAD1000, even if it is forward of the LERL. Euro NCAP monitors performance at the LERL as far forward as WAD930 if the LERL is forward of WAD1000, although this does not factor into the score.

- For many smaller vehicles the forward line where testing is required is at WAD1000, far behind the LERL, which means much of the hood (the forward portion) would not be subject to headform testing. We note that

<sup>109</sup>The Child Headform is launched at 50 degrees down from the horizontal and would impact a vertical surface at 50 degrees from a purely perpendicular impact.

subjecting these forward areas of the hood to the standard may benefit children smaller than the average 6-year-old. A potential way to subject the forward areas to testing could be the same as that suggested above for larger vehicles, *i.e.*, selection of the test area boundary based on the *forward-most* of the WAD1000 or of the Offset Line, rather than the *rearward-most*. We ask for comment on this issue in the context of smaller vehicles.

- As discussed above, another alternative on which we request comment involves how the GTR determines the HIC Unlimited Margin for the front and sides. (Impacts in the HIC Unlimited Margin are not subject to any HIC limit.) The NPRM's regulatory text reflects the GTR's specification that the margin would be determined using an 82.5 (3.25 inch) mm taut wire, but NHTSA finds merit in using a 50 mm (1.97 inch) taut wire instead to increase the testable area, and reduce the allowable area of the HIC Unlimited Margin.

2. Transition Between Child and Adult Headform Test Areas at WAD1700

Consistent with the GTR, proposed FMVSS No. 228 would separate the Child Headform Test Area from the Adult Headform Test Area at WAD1700. For many smaller vehicles, it is possible that there would be no Adult Headform Test Area at all when the transition between the child and adult test areas is drawn at WAD1700. Consistent with the GTR, proposed FMVSS No. 228 would require that, if there is only a Child Headform Test Area, the requirements that applied to the combined Child and Adult Headform Test Area are applied to the Child Headform Test Area alone. For example, at least two-thirds of the numerical value of the Hood Area, when placed within the boundary of the Child Headform Test Area (as opposed to the combined areas) must not exceed HIC of 1000 using the child headform. For the remaining area the HIC shall not exceed 1700.

This NPRM uses WAD1700 to transition between the Adult and Child Headform Test Areas because GTR data indicate that 6- to 15-year-old child head impacts start at about WAD1000 and end at WAD1700. A 5th percentile female has a standing height of an average 12-year-old child and would likely have a head impact within the Child Headform Test Area. Consistent with this, figure VI.17 below from the

Pedestrian Crash Data Study (PCDS) shows that for all adults, impacts start at about WAD1400 and end at WAD2400. PCDS shows that about 70% of all adult pedestrian head impacts are between WAD1000 and WAD2100. Separating the genders, about half of adult female and one third of adult male head impacts are between WAD1000 and W1700 (not depicted in figure VI.17). As shown in figure VI.17, the

WAD1700 represents the 75th percentile for children under age 10 and the 25th percentile for all adults. Because stature distribution has remained stable over the past two decades<sup>110</sup> and because WAD has been shown to depend primarily on the pedestrian's stature for a particular vehicle impact speed,<sup>111 112 113</sup> this WAD distribution would still be representative today.

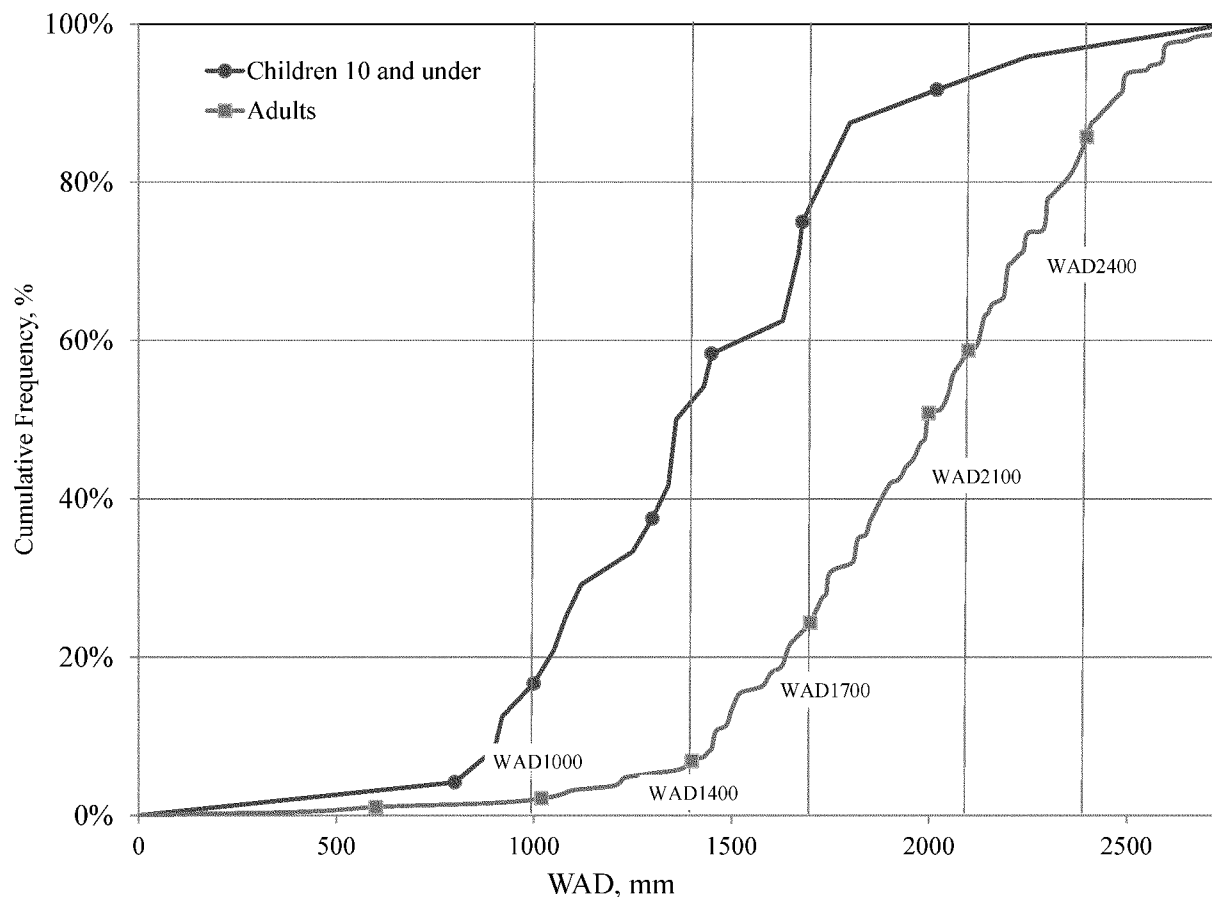

**Figure VI.17. Cumulative frequency of pedestrian head strike WAD measurements.**  
Source: PCDS.

Data show that child-adult overlapping of impacts occurs between 1400 and 1700 mm. The drafters of the GTR considered whether to use a test method where the child and adult test areas overlap or whether a step change should be used, and where it should be drawn. The goal was to ensure that the transition area would provide protection against both child and adult head

impacts. The drafters considered an approach to specify a test area (transition zone) in which both a child headform and an adult headform would be used to assess compliance, because both children and adults strike this area. Such a transition zone could, for example, be WAD 1400—WAD1700 or WAD1500—WAD1700. They also considered, and ultimately adopted, a

sudden transition (step change) approach. However, the NCAP RFC and Euro NCAP test procedures have adopted a transition zone between WAD1500—WAD1700, where both impactors must be used if the RRL is between WAD1500 and WAD1700.

The rationale supporting a step change approach is that a sudden step change in hood performance is not

<sup>110</sup> Fryar CD, Kruszon-Moran D, Gu Q, Ogden CL. Mean body weight, height, waist circumference, and body mass index among adults: United States, 1999–2000 through 2015–2016. National Health Statistics Reports; no 122. Hyattsville, MD: National Center for Health Statistics. 2018.

<sup>111</sup> Ivarsson J, et al. "Pedestrian Head Impact—What Determines the Likelihood and Wrap Around Distance?", 20th Enhanced Safety of Vehicles Conference (2007); paper no. 07-0373.

<sup>112</sup> Kiuchi T, et al. "Comparative Study of VRU Head Impact Locations," Sixth Expert Symposium

on Accident Research (ESAR). Hanover, Germany (2014).

<sup>113</sup> Otte, D. "Wrap Around Distance WAD of Pedestrian and Bicyclists and Relevance as Influence Parameter for Head Injuries," SAE Technical Paper 2015-01-1461, 2015.

likely to be engineered into the design of a hood, and that a step change approach reduces the need to conduct unnecessary headform tests. In practice, a sudden step change produces a hood design with an area around the transition line that is safe for both child and adult pedestrians. Therefore, it was decided that a hood designed for overlapping child-adult safety is effectively achieved without the need to specify the use of two headforms. Further, a defined boundary at 1,700 mm provides a clearer approach. The GTR adopted the step change approach with a transition at WAD1700, which biases protection towards children. That is, the use of WAD1700 makes more of the hood tuned to protect a child's head than an adult head. Rather than having to design hoods for both head masses, the use of a non-overlapping transition at WAD1700 allows safety in the transition area to be optimized for the lighter headform.

#### Request for Comment on the Transition Zone

- NHTSA tentatively agrees with the above reasons and has drafted the regulatory text of proposed FMVSS No. 228 to specify a non-overlapping transition from the Child Headform Test Area to the Adult Headform Test Area at WAD1700. However, we request comments on the merits of a transition zone. We would like to know more about the degree to which a step change approach addresses safety for both adults and children for vehicles that have sharp changes in structure, such as the joint between the rear of the hood and the cowl, which may occur along the transition line. This is indeed the case for many smaller vehicles which have no Adult Headform Test Area at all when the transition is drawn at WAD1700. While this helps with design feasibility for such vehicles (requirements apply for the lighter headform only), it may reduce the safety of such vehicles for shorter adult pedestrians because the hood may not provide sufficient penetration depth for the heavier adult headform. We therefore seek comment on other options for FMVSS No. 228. These options may include a revised procedure in which the adult/child border is drawn at a different WAD and use of a transition area that is tested with both headforms.

#### 3. Rear Border of Adult Headform Test Area

Consistent with GTR 9, the rear border of the Adult Headform Test Area is the HIC Unlimited Margin of the Rear Reference Line, which is the WAD2100

line or the 82.5mm offset line, whichever is more forward. WAD2100 is based on the average height of a 50th percentile adult male, which is about 1750 mm. This height is about the 97th percentile for adult females in the U.S.<sup>114</sup>

#### d. Considerations for the Adult Headform Test Area Rear Border; Request for Comment

NHTSA is considering several changes to the GTR approach related to the rear border of the Adult Headform Test Area to increase the test area. These considerations offer the potential of providing increasing pedestrian protection to individuals taller than the average male, and to individuals involved in higher speed impacts.

1. First, we are considering including headform testing of the windshield. This NPRM's regulatory text does not include testing of the windshield, A-pillars or top edge of the windshield, which is reflective of GTR 9's text. The GTR excludes the A-pillars and top edge of the windshield from the test area because of practicability reasons, and NHTSA generally agrees with excluding those areas. It is difficult to reduce the stiffness of the windshield frame because it serves as a support structure and helps to ensure the integrity of the occupant compartment. Furthermore, in the lower windshield area the requisite deformation space to meet HIC is restricted by the dashboard and instrument panel. Some components must be positioned in the dashboard and instrument panel to provide occupant protection (*e.g.*, air bags) and crash avoidance safety, *e.g.*, defrosting requirements, forward-view sensors for automatic emergency braking, and rearview cameras. In addition, the structural components of the dashboard comprise important load paths in front and side crashes that contribute to occupant crash protection.

The GTR drafters excluded the windshield for different reasons, finding that the windshield itself does not cause severe injuries and therefore the number of casualties averted would be very low. The center of the windshield—away from the edges—generally produces good safety scores, although impacts near the A-pillars universally produce poor results. This is consistent with real-world data which show that fatal injuries are more common when the head strikes the windshield frame rather than the center area.<sup>115</sup>

<sup>114</sup> Based on 2007–2010 NHANES from <https://tools.openlab.psu.edu/tools/explorer.php>.

<sup>115</sup> Fredriksson R (2011), Priorities and potential of pedestrian protection—accident data,

Nonetheless, NHTSA is concerned that head-to-windshield impacts are associated with a high incidence of pedestrian injuries. One reason is that a head-to-windshield impact may have a higher velocity than a head-to-hood impact.<sup>116</sup>

NHTSA has also observed that vehicle designs have changed in recent years in that windshields are more forward on the hood, where the cowl may begin at WAD1700. WAD1700 separates the Child Headform Test Area from the Adult Headform Test Area. Because the area rearward of the cowl is excluded from the headform test area, these vehicles have hoods that would only have a Child Headform Test Area and would be tested only with a child headform. NHTSA is concerned that these designs may be particularly detrimental to shorter adult pedestrians who are more apt to strike the hood near the cowl than in the case of designs of predecessor vehicles whose cowls began at a higher WAD measurement. Extending the test area into the windshield may serve to disincentivize such designs by eliminating the compliance advantage that may come with limiting the hood size to WAD1700. Further, the windshield itself on these vehicles tends to be more horizontal than vertical, and so a larger portion of the windshield lies directly above and near the dashboard panel where there is less penetration depth to protect the head. The extended windshield (*i.e.*, a windshield placed immediately beyond WAD1700) may also be stiffer than the portion of the hood that would otherwise have covered the same area. Extending the test area into the windshield may serve to protect pedestrians who may strike this stiffer portion of the windshield.

NHTSA has also observed the development of automated rideshare vehicles and other modern EVs with very flat fronts, with the base of the windshield or windshield-like areas at very small WAD locations compared to traditional vehicles. For such vehicles, exclusion of the windshield-like areas would essentially permit the vehicle to not provide any form of pedestrian head protection.

Finally, as we noted above, some of these automated vehicles appear to have

experimental tests, and numerical simulations of car-to-car pedestrian impacts. Doctoral Thesis, Department of Public Health, Karolinska Institutet, Stockholm, Sweden, 2011.

<sup>116</sup> Kerrigan J, Arregui C, Crandall JC (2009), Pedestrian head impact dynamics: comparison of dummy and PMHS in small sedan and large SUV impacts, Paper No. 09-0127, 21st International Technical Conference on the Enhanced Safety of Vehicles Conference (ESV)—International Congress Center Stuttgart, Germany, June 15–18, 2009.

a windshield-like area, but it is not a windshield in the traditional sense since it is not transparent. For such vehicles, the RRL would not exist since it is determined by inserting a 165 mm sphere into the cowl and against the windshield such that the sphere is in contact with the windshield and a point on the surface of the hood (usually its rear edge). For such vehicles, the rear boundary of the Hood Area and Adult Headform Test Area would be defined by the WAD2100 line. Comments are requested on how the test area should be determined for vehicles with no traditional windshield and on the merits of determining the rear boundary of the Hood Area and Adult Headform Test Area by WAD2100 for such vehicles, as would be the case for the proposed regulatory text.

As for practicability, NHTSA has performed eleven tests into the windshield as part of the testing documented in table VII.1, below. Of those eleven tests, nine had HIC below 1000 and the other two tests were HIC below 1700, which support a finding that testing of at least some portion of the windshield may be reasonable and practicable.

It is the agency's understanding that UNECE Reg. No. 127 has a proposal to specifically add the windshield as a new test area.<sup>117</sup> This area is bound, in the front, by a line 100 mm rearward of the blacked-out (non-transparent) portion of the windshield base and in the rear by WAD2500 or a line 130 mm forward of the rear edge of the windshield, whichever is more forward at a given lateral position. The side border is 100 mm inside of the blacked-out area. Adding the windshield to UNECE Reg. No. 127 would indicate the provisions of GTR 9 are appropriate for the windshield.

- Given the above, there appears to be merit to including the windshield in a test area for FMVSS No. 228. The regulatory text of this NPRM does not include the windshield, but NHTSA is considering language for a final rule that would include the windshield. The NCAP RFC and various international NCAP programs that assess pedestrian safety (Euro NCAP, Japan NCAP, Korea NCAP, and Australian NCAP) include a head-to-windshield impact test area. In addition, a UNECE Reg. No. 127 proposal also includes the windshield for testing.

2. The next subject for consideration is the limitation of testing beyond WAD2100. Consistent with GTR 9, this NPRM's regulatory text states that the rear border of the Adult Headform Test

Area is either WAD2100 or the HIC Unlimited Margin of the Rear Reference Line, whichever is more forward. However, the ECE proposal mentioned above changes WAD2100 to WAD2500. That is, the rear border of the Adult Headform Test Area ("Adult Bonnet Top Headform Test Area" in the ECE proposal) would be changed from the forwardmost of WAD2100 or the 82.5 mm offset line, to the forwardmost of WAD2500 or the 82.5 mm offset line. The change to WAD2500 would increase the test area. We are also aware of similar changes to the Euro NCAP requirements being implemented in 2023, with the area between WAD2100 and WAD2500 being referred to as the Cyclist Zone.<sup>118</sup> WAD2500 might extend past the windshield to the roof, and, under Euro NCAP procedures, the A-pillars are tested. Any impacts to the roof under Euro NCAP procedures involve a 45-degree angle rather than 65 degrees. We are considering similarly changing WAD2100 to WAD2500 for FMVSS No. 228.

The specification of WAD2100 recognizes that the point of head contact—relative to the height of the pedestrian—moves further rearward as pedestrian stature increases. WAD2100 corresponds to the typical head impact location of a pedestrian with a height of 1,750 mm for a vehicle speed of 40 km/h. A height of 1,750 mm is approximately the height of a 50th percentile male. For most passenger cars and minivans, WAD2100 lies rearward of the Rear Reference Line (RRL) (which is at the cowl) so WAD2100 would not be consequential as it would not be used to define the rear border of the hood area. However, for some larger vehicles in the U.S., the WAD2100 line can be forward of the RRL, which means that WAD2100 would be the rear border of the testable area of the hood even though there could be parts of the hood rearward of that WAD2100 line.<sup>119</sup>

- We seek comment on moving the rear boundary of the test area consistent with using WAD2500 as the reference, rather than WAD2100. Such a change has been proposed for UNECE Reg. No.

<sup>118</sup> Euro NCAP Vulnerable Road User Testing Protocol <https://cdn.euroncap.com/media/70319/euro-ncap-vru-testing-protocol-v901.pdf>.

<sup>119</sup> NHTSA recognizes that moving the WAD line rearward to account for head impacts rearward of WAD2100 could bear on other aspects of the test procedure, such as the velocity of the headform impact in the test, because actual pedestrian head impact velocities are generally higher at WADs greater than 2100 mm. This means that, if the WAD line were moved rearward of WAD2100, the agency would carefully consider whether adjustments would be appropriate to the test procedure to ensure the continued relevance of the procedure relative to a real-world impact at WADs greater than 2100 mm.

127 and Euro NCAP. We also seek comment on the need for a modified impact angle for the roof, if moving to a WAD2100 boundary results in headform testing in the A-pillar or roof areas.

3. Another issue that arises in defining the Adult Headform Test Area rear boundary is that the GTR uses the *most forward* of either WAD2100 or the 82.5 mm offset line. Figure VI.18 shows an example where the WAD2100 is the rear boundary of the Adult Headform Test Area. For the final rule, NHTSA is considering enlarging the test area rearward by considering the *most rearward* of these borders.

- Regardless of any change to the WAD reference, we request comment on using the *most rearward* of the WAD line or offset line to define the rear boundary of the Adult Headform Test Area, rather than using the line that is most forward.

4. We are also considering reducing the HIC Unlimited Area by using a 50 mm (1.97 inch) offset line rather than an 82.5 mm (3.25 inch) offset line at the rear of the Hood Top. This HIC Unlimited Margin at the rear of the Hood Top was originally written into the GTR to prevent a test anomaly where the headform could hit the windshield and the hood simultaneously. However, NHTSA believes that the use of the 165 mm sphere to define the RRL works adequately to prevent situations where the headform could contact the windshield and hood simultaneously. We also note that the NCAP RFC and Euro NCAP do not consider impact points on the hood that are a distance less than 50 mm from the Side Reference Line (SRL) measured in the lateral direction; *i.e.*, they use what amounts to a 50 mm offset line rather than an 82.5 mm offset.

- Accordingly, while the regulatory text of this NPRM uses an 82.5 mm Offset Line, NHTSA is considering using a 50 mm Offset Line rather than an 82.5 mm Offset Line to define the rear HIC Unlimited Margin. The reduced Offset Line would make more of the hood on larger vehicles subject to headform testing. NHTSA requests comments on the merits of the agency's adopting a 50 mm Offset Line in the final rule.

5. Finally, we are considering and request comments on the merits of including the entire Hood Top as the testable area. This would mean the elimination of the HIC Unlimited Area completely, of both the Child and Adult Headform Test Areas, and expansion of the front test border to the LERL and the rear border to the RRL. We discuss this

<sup>117</sup> ECE/TRANS/WP.29/GRSP/2021/28.

in more detail in section XI, Considered Alternatives.

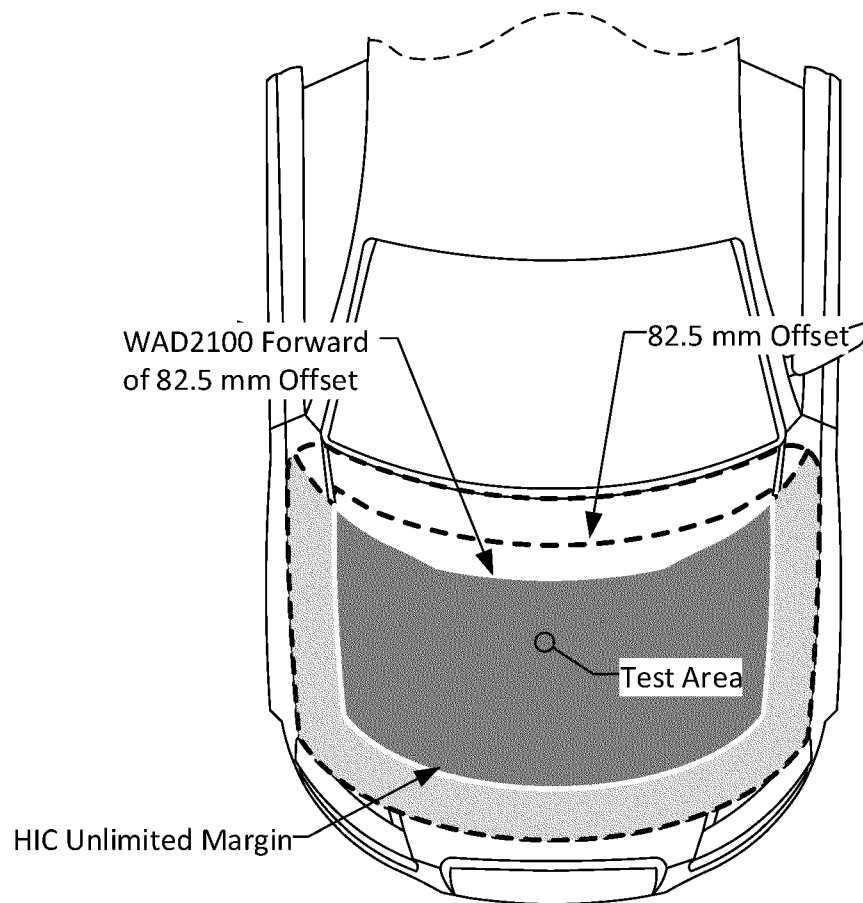

**Figure VI.18. Example showing WAD2100 forward of the 82.5mm Offset Line, forming the rear boundary of the Adult Headform Test Area. For illustration purposes only.**

#### 4. Corner Reference Point of the Child Headform Test Area

Finally, we believe it is also necessary to define a corner reference point for the test areas (specifically the Child Headform Test Area), just as it is for the Hood Area. The rationale is the same as for the Hood Area, *i.e.*, we need to clearly define the extent of the test area. There may be multiple intersections between the front border of the Child Headform Test Area (HIC Unlimited Margin of the LERL) and the side border of the Child Headform Test Area (HIC Unlimited Margin of the SRL). The definition would make clear that we would be using the most outboard intersection when there are multiple intersections of the front and side borders. This term would be called the “Corner Reference Point of the Child Headform Test Area.”

#### VII. Proposed Requirements and Assessing Compliance

##### A. Amount of Hood Area That Must Conform to HIC1000

Consistent with GTR 9, the regulatory text of this NPRM prescribes the amount of the Child and Adult Headform Test Areas that must conform to a HIC1000 limit (HIC1000 Area). The remainder of the Child and Adult Headform Test Areas must be able to conform to a HIC1700 limit (HIC1700 Area).

The basis for the minimum HIC1000 Area is the size of the Hood Area. After the Hood Area is determined, the performance requirements would be applied as follows:

(1) The numerical value of two thirds of the Hood Area is calculated. At least this amount of area, when placed within the boundary of the Combined Child and Adult Headform Test Area, must

not exceed HIC1000.<sup>120</sup> As we explained in section VI.C, the Child Headform Test Area and the Adult Headform Test Area are defined in a manner that excludes “HIC Unlimited” margins in the Hood Area. Thus, the requisite HIC1000 areas described in this paragraph (1) and in paragraph (2) (below) must fit into the respective headform test areas contained inside of the HIC Unlimited margins.

(2) The numerical value of one-half of the Hood Area under WAD1700 is calculated. At least this amount of area, when placed within the boundary of the Child Headform Test Area, must not exceed HIC1000.

(3) For all other tests, HIC must not exceed HIC1700.

<sup>120</sup> If the numerical value of two thirds of the Hood Area exceeds the combined Child and Adult Headform Test Area, the entire combined Child and Adult Headform Test Area must be HIC1000 Area.

In sum, under the provisions described above:

- One-half of the numerical value of the Hood Area that lies below WAD1700, when placed in the Child Headform Test Area, must meet HIC1000.

- At least two-thirds of the numerical value of the entire Hood Area, when placed within the Combined Child and Adult Headform Test Area, must meet the HIC1000 requirement.

- In the event the numerical value of two-thirds of the Hood Area exceeds the Combined Child and Adult Headform Test Area, the entire Combined Child and Adult Headform Test Area must meet HIC1000. There would be no HIC1700 area.

- There may be cases where there is no Adult Headform Test Area; in such cases, by definition, the Child Headform Test Area represents the entire test area. In that case, the one-half requirement in the Child Headform Test Area does not apply. Instead, the HIC recorded shall not exceed 1000 over two-thirds of the Hood Area when placed within the Child Headform Test Area, since it represents the entirety of the test area. For the remaining Child Headform Test Area, the HIC shall not exceed 1700. All tests in the Child Headform Test Area would be with the child headform.

Proposed FMVSS No. 228 would provide manufacturers considerable flexibility in designing their hoods to provide the protective HIC1000 area. They have the flexibility to account for hard points under the hood that prevent the hood from meeting HIC1000. As explained below, upon request, under NHTSA's enforcement authority, they must report their design choices to NHTSA, so that the agency will know the locations of the HIC1700 areas and can assess the compliance of the vehicle based on that information.<sup>121</sup>

#### B. Manufacturer Designations of HIC1700 Areas

Upon request and under the authority provided in 49 U.S.C. 30166, manufacturers would be required to identify to NHTSA the HIC1700 portions of the test areas.<sup>122</sup> The HIC1700 areas need not be continuous and are not limited in number. They may consist of an unlimited number of portions as long as the requisite

HIC1000 area is met by the vehicle. However, a manufacturer must attest to the information by the time it certifies the vehicle, and the declaration would be irrevocable. Thus, in a compliance test, manufacturers would not be permitted to change the attestation and claim that an impact that was previously designated as being in the HIC1000 area is now in a HIC1700 area after the impact results in an HIC value above HIC1000.

FMVSS No. 228 would place some conditions on manufacturers' designations of HIC1700 areas. When the HIC1700 area is contiguous with reference lines, HIC Unlimited margins or WAD lines set forth in FMVSS No. 228, the lines determined according to the standard would supersede any conflicting coordinates provided by the manufacturer. In other words, the borders as set forth in the standard are definitive and NHTSA will use the procedures to determine the relevant areas on the hood without manufacturer input.<sup>123</sup> Upon request, manufacturers must tell NHTSA where the HIC1700 areas are by providing coordinates or decals. If these coordinates or decals conflict with the provisions of FMVSS No. 228, NHTSA would conduct compliance tests using the reference lines of the test area borders as determined by the standard, and not the manufacturer's description of the location of test area borders.

To enable more efficient compliance testing, this NPRM specifies ways in which the HIC1700 areas would be disclosed to NHTSA. This NPRM proposes to require manufacturers to identify HIC1700 areas by providing the (x,y) coordinates of their borders referenced from the intersection of WAD1000 and the longitudinal centerline of the vehicle.<sup>124</sup> The number of coordinates and the spacing of the coordinates would be provided at the discretion of the manufacturer, but the points would have to be joined by straight lines in the x-y plane when marking off the test areas of an actual vehicle. In lieu of (x,y) coordinates, we propose that the manufacturer could provide decals or templates with registration marks (marks used for alignment) referenced from the

intersection of WAD1000 and the vehicle longitudinal centerline.

#### Request for Comment on Allocating HIC1700 Area

- Under the GTR, when the Adult Headform Test Area is relatively small compared to the Hood Area, it is possible in some instances for a manufacturer to define *all* of the adult area as HIC1700 Area and still meet the requirement that the numerical value of two-thirds of the Hood Area be HIC1000 Area. In such an instance there would be no HIC1000 requirement for the adult headform. This raises a concern to us because then, real-world adult pedestrian head strikes would likely only be in HIC1700 area (and not in the more protective HIC1000 area). We request comment on whether the final rule should require that HIC1700 areas be allocated such that at least *some* HIC1000 area must be provided in the Adult Headform Test Area.

#### C. First Point of Contact

Under the proposed FMVSS No. 228 test procedures, with the agency knowing the manufacturer's information identifying the HIC1700 areas, NHTSA would launch a headform at the hood. The standard would take a simple approach to determine the HIC requirement that applies to a particular impact. For any given headform launch, NHTSA would identify the first point of contact between the headform and the hood. NHTSA's proposed method of targeting areas on the hood and assigning HIC values through the first point of contact is consistent with NHTSA's interpretation of GTR 9, and we refer to it as the "3D Method." If the impact is in a HIC1000 area, the headform must measure a HIC equal to or less than 1000 for the vehicle to pass the test. If the impact is in a HIC1700 area, the headform must measure a HIC equal to or less than 1700. We will test as many points on the hood as we deem necessary to assure the vehicle complies with the standard.<sup>125</sup> If a test finds that the HIC is greater than the limit prescribed by the standard, we will investigate the finding as a potential noncompliance in accordance with NHTSA's Office of Vehicle Safety Compliance protocol.

<sup>121</sup> As discussed in section VIII.B below, there are pending proposed GTR 9 amendments that would substantially reduce the amount of required HIC1000 area.

<sup>122</sup> In drafting this NPRM, NHTSA decided it would not matter substantively if manufacturers had to identify the HIC1000 or the HIC1700 portions, but identifying the HIC1700 portions seems more straightforward since that area would be smaller than the HIC1000 areas.

<sup>123</sup> When marking off the vehicle as described in this NPRM, only the HIC1700 areas are derived from information supplied by the manufacturer. All other borders will be drawn up on each individual vehicle in accordance with the standard's regulatory text and NHTSA's compliance test procedure (TP); they need not be determined based on manufacturer information.

<sup>124</sup> If no HIC1700 area is provided by the manufacturer, the child or adult test areas would be tested as HIC1000 area.

<sup>125</sup> We recognize the potential that dents caused by headform impacts on one part of the hood may affect the performance of the hood in subsequent tests, depending on location of the impacts. NHTSA's Office of Vehicle Safety Compliance (OVSC) will issue a test procedure guidance document that would describe the agency's protocol for conducting a compliance test. The test procedure would explain NHTSA's protocol for changing out hoods between impactor tests.

We recognize the possibility that the first contact of the headform could occur at multiple points on the hood simultaneously due to the curvature of the hood and the headform, and that these points could lie in different test areas. For example, one point could lie in the HIC1000 portion of the Child Headform Test Area and another could lie in the HIC1700 of the Adult Headform Test Area. To address this problem, we propose to use a simple and common-sense approach to cover instances where the first contact occurs in more than one area: when such a situation arises, the more stringent requirement applies.<sup>126</sup> For example, if first contact occurs in a child HIC1000 area and a child HIC1700 area simultaneously, the HIC1000 requirement applies for that particular launch location. If the first contact occurs in both the Child Headform Test Area and the Adult Headform Test Area (e.g., multiple simultaneous contact points), requirements for both headforms would need to be met. That is, NHTSA could perform more than one test of the same point with the different headforms.

Proposed FMVSS No. 228 would not specify how many tests NHTSA would conduct on a particular hood or where precisely the headforms would be aimed (such as minimum spacing between the test points on the hood). NHTSA agrees with the drafters of the GTR that the specification of such points is not necessary because, for Contracting Parties such as the United States that use a self-certification regulatory framework, specifying the number of tests required for testing or the spacing of test points is unnecessary. Under NHTSA's statutory framework and proposed FMVSS No. 228, it would be incumbent on vehicle manufacturers to ensure that their vehicles comply with all the impact zone requirements defined within the standard when tested by NHTSA. Accordingly, proposed FMVSS No. 228 does not specify these provisions.

<sup>126</sup> With Contracting Parties like Japan and the E.U., situations like this are worked out between the manufacturer and the type approval authority. In contrast, the Safety Act provides for a self-certification framework—so NHTSA does not approve vehicles before sale—and requires the FMVSS to be objective. This means that the FMVSS must be capable of producing identical results when tests are conducted in identical conditions and compliance must be based on scientific measurements, not on opinions that could vary from individual to individual and be subjective.

#### *D. Consideration Related to the Amount of Test Area That Must Meet the HIC1000 and HIC1700 Limits*

In section VII.A, we explained the requirement for the amount of test area within the Child and Adult Headform Test Areas that must be capable of achieving HIC not greater than 1000. The basis for this amount of area is two-thirds of the Hood Area, and the Hood Area by definition is always larger than the test area. Thus, more than two-thirds of the test area must be HIC1000 Area, and the remainder (less than two-thirds) must be HIC1700 Area. More than a decade and a half of agency testing with the pedestrian headform to the specifications of the GTR show that this level of performance is practicable.

NHTSA's pedestrian headform testing provides the data needed to understand the distribution of HIC outcomes on U.S. vehicle hood areas. Test data have been collected in numerous research studies<sup>127</sup> that have included 2001–2021 model year vehicles. These data, which also include 6 data points for 1994 Honda Civic and 8 data points for 1999 Dodge Dakota, provide the basis for the estimates in the PRIA. Over the years, this testing has kept NHTSA well-informed about the evolving status of pedestrian protection for the U.S. vehicle fleet. A total of 344 headform impact tests were analyzed to understand the feasibility of meeting both HIC1000 and HIC1700 performance requirements in both central (within the Child and Adult Headform Test Areas) and peripheral (near/outside the HIC Unlimited Margin<sup>128</sup>) areas of vehicle front ends. Out of the 272 tests, only 28 (10.3%) of the impacts, regardless of impact location, failed to meet HIC1700 (table VII.1). For tests within the Child and Adult Headform Test Areas, 75 of 87 impacts (86.2%) met the HIC1000 limit and another 10 impacts (11.5%) were between HIC1000 and HIC1700.

<sup>127</sup> Reference 1—NHTSA “VRTC Pedestrian Research Activities” GTR No. 9 Informal Working Group Document #WP29-144-03 (2006); Reference 2—Mallory A, et al. “Pedestrian GTR Testing of Current Vehicles” ESV (2007); Reference 3—Suntay B, et al. “Vehicle Hood Testing to Evaluate Pedestrian Headform Reproducibility, GTR No. 9 Test Procedural Issues, and U.S. Fleet Performance,” NHTSA Docket NHTSA–2008–0145–0014 (2018); Reference 4—Suntay B, et al. “Pedestrian Protection: U.S. Vehicle Fleet Assessment,” DOT HS 812 723 (2019); Reference 5—Suntay B, et al. “Assessment of Hood Designs for Pedestrian Head Protection: Active Hood Systems,” DOT HS 812 762 (2020); Reference 6—Suntay B, et al. “Vehicle Assessment using Integrated Crash Avoidance and Crashworthiness Pedestrian Safety Test Procedures.” DOT HS 813 521.

<sup>128</sup> As explained earlier in this preamble, the “HIC Unlimited Margin” is the inner boundary of the HIC Unlimited Area.

Only 2 impacts (2.3%) within the Child and Adult Headform Test Area exceeded HIC1700. For tests near/outside the HIC Unlimited Margin, 79 of 185 impacts (42.7%) met HIC 1000. Further, when only model year 2010 or later vehicles are considered, there were only 8 instances out of 155 tests (5.2%) that were above HIC1700, including impacts in the HIC Unlimited Area. Again, restricting this to tests in the proposed test area, 34 of 40 impacts (85%) were below HIC1000, 5 of 40 (12.5%) were between HIC1000 and HIC1700 and 1 of 40 (2.5%) was above HIC1700.

This analysis is considered a conservative approximation of practicability (it underestimates the degree to which vehicles could meet the proposed limits) for four reasons.

First, 109 of these 272 tests were conducted at the NCAP RFC and Euro NCAP test velocity of 40 km/h, which is higher than the 35 km/h speed proposed here. The HIC outcomes in those tests would be expected to be lower if the proposed 35 km/h impact speed were employed at those same impact locations. On the other hand, the 33 tests included in the Ref. 1 study were conducted at 32 km/h since, at the time that research was performed, the draft GTR procedure specified that lower impact speed. Those same tests would be expected to have slightly higher HIC at a speed of 35 km/hr. All of those test outcomes were included in the analysis; however, it should be noted that there were over three times as many tests at 40 km/hr as there were at 32 km/h in the sample. Second, as noted earlier, vehicle designs have gotten more protective over the years as evidenced by the lower HIC outcomes in more recent vehicles.

Third, we note that certain tests have not been included in our analysis of practicability, but note them here for completeness. Eleven NHTSA tests into the windshield were not included since the windshield is not covered by the GTR. However, of those eleven tests, nine had HIC below 1000 and the other two tests had HIC below 1700, which supports a finding that the HIC 1000 and 1700 limits are reasonable and practicable. Finally, six tests on fully deployed pop-up hood systems from two vehicles (see Ref. 5) were not included in this analysis, since those tests included European-market-only hood actuator components installed on a U.S. vehicle and it is unclear how such vehicles would have been configured if FMVSS No. 228 were in place. Nonetheless, all six of those tests had HIC below 1000. Taken together, inclusion of these additional data would

indicate 17 tests with HIC below 1700 and 15 of 17 with HIC below 1000.

TABLE VII.1—DISTRIBUTION OF HIC OUTCOMES IN NHTSA TESTING  
[MY 2001–2021 vehicles]

Source of data (vehicle model years)	Child/adult test area			Near/outside HIC unlimited margin		
	# Tests	HIC <1000	HIC <1700	# Tests	HIC <1000	HIC <1700
Ref. 1 (2001–2004) .....	11	11	11	22	12	19
Ref. 2 (1999–2006) .....	36	30	35	48	9	32
Ref. 3 (2010–2011) .....	.....	.....	.....	46	26	46
Ref. 4 (2015–2017) .....	31	26	31	51	21	46
Ref. 5 (2014) .....	1	0	0	2	0	0
Ref. 6 (2016–2021) .....	8	8	8	16	11	16
Total .....	87	75	85	185	79	159
Pct within HIC req. ....	.....	86.2%	97.7%	.....	42.7%	85.9%

\* Note that impact locations with respect to the HIC Unlimited Margin needed to be estimated in some cases where the margin was unknown. Also note that tests in this analysis included impact speeds from 32–40 km/h. Therefore, these numbers should only be considered approximate with respect to the proposed 35 km/h test speed and HIC Unlimited Margin locations on future vehicle front ends.

NHTSA understands that these data represent discrete points on the hood surface tested in the program and do not describe the performance of any particular vehicle hood in its totality. Nonetheless, taken together, the analysis of existing NHTSA-performed pedestrian head impact testing indicates that the proposed compliance limits and requirements for proposed FMVSS No. 228 are practicable for U.S. vehicles.

*E. Considerations for Expansion of Test Area When It Is Less Than Two Thirds of the Numerical Value of the Hood Area*

Although very rare, based on the vehicles tested by NHTSA, it appears possible for the numerical value of two thirds of the Hood Area to exceed the Combined Child and Adult Headform Test Area.<sup>129</sup> While this can only occur when the test area is very small, NHTSA would like to make clear that, in this situation, the proposal requires that the entire Combined Child and Adult Headform Test Area be HIC1000 Area. Stated differently, for such a vehicle, if there is no “remaining area,” there would be no HIC1700 Area. We believe this view of the proposed standard is consistent with GTR 9, but GTR 9 does not appear to set forth any explicit contingencies for this occurrence. NHTSA takes the view that the entire Combined Child and Adult Headform Test Area must meet HIC1000 out of a concern that permitting a HIC1700 area for such a vehicle would result in less than two thirds of the Hood Area being tested to the HIC1000 threshold. This means that such a vehicle would provide less protection to pedestrians

than all other vehicles (with larger hoods). Moreover, to address and improve upon this situation, NHTSA is considering expanding the test area to encompass at least two thirds of the Hood Area on these vehicles when the test area, as currently defined, is smaller than two thirds of the Hood Area. The entirety of the test area would remain HIC1000 Area to remain consistent with the provision that the numerical value of two thirds of the Hood Area be HIC1000 Area. NHTSA requests comment on whether the test area increase should simply be a proportional expansion of the entire test area.

**VIII. GTR 9 Terminology and Amendment 3**

In drafting the regulatory text of this NPRM, one of NHTSA’s goals has been to produce a proposal that has a high degree of fidelity to GTR 9. However, we have found the need to define some terms in a slightly different way than the GTR to produce an objective standard that meets the requirements of the Safety Act and the needs of the self-certification environment in the United States. In this section, we highlight some of the differences in terminology between GTR 9 and FMVSS No. 228, after which we provide details related to, and request comments on, an “Amendment 3” proposal that has since 2021 reemerged as the source of potential revisions to GTR 9.

*A. Comparison of Terminology*

As we explained in section VI of this preamble, the major components that constitute the hood are the Hood Top, Hood Area, Child Headform Test Area,

Adult Headform Test Area and HIC Unlimited Area. In some cases, GTR 9 uses identical or very similar terminology; however, the terminology sometimes does not have the same meaning. In other cases, the terminology is different or the terms do not exist. Table VIII.3 references the terms defined in FMVSS No. 228 (first column) and the related terms in GTR 9 (second column). The focus here is on the terms used to define the hood surface and tested area.

The term Hood Top and its related borders, shown in rows 1–4 of table VIII.3, has equivalents in GTR 9, *i.e.*, *Bonnet Top*, *Side Reference Line*, etc. The term Hood Area in FMVSS No. 228 is represented in GTR 9 by the combined *child headform test area* and *adult headform test area*. We note that the GTR 9 *child headform test area* and *adult headform test area* are larger than the similarly named areas in FMVSS No. 228, because GTR 9 does not subtract the HIC Unlimited Area from the GTR child and adult headform test areas. Just as the Hood Area forms the basis of the amount of area needing to have a HIC of 1000 or less in this NPRM, GTR 9 states at S5.2.3 that “two thirds of the combined child and adult headform test areas” must meet this requirement. Hood Area and the analogous GTR terms are shown in rows 5–8 of table VIII.3.

The area described in the “Child Headform Test Area” term in FMVSS No. 228 is not described by a specific term in GTR 9. However, an equivalent set of borders for defining the area is provided in S7.3.2 of GTR No. 9 (see table VIII.1).

<sup>129</sup> The only vehicle tested by NHTSA where this occurred was on the 2004 GM Savana. For this

vehicle the numerical value of the two thirds of the

Hood Area was essentially the same as the Test Area.



TABLE VIII.1

S7.3.2 of GTR 9

Selected impact points on the bonnet for the child headform impactor shall be, at the time of first contact:

- (a) a minimum of 82.5 mm inside the defined side reference lines, and;
- (b) forward of the WAD1700 line, or, a minimum of 82.5 mm forwards of the bonnet rear reference line, —whichever is most forward at the point of measurement, and;
- (c) be rearward of the WAD1000 line, or, a minimum of 82.5 mm rearwards of the bonnet leading edge reference line, —whichever is most rearward at the point of measurement.

Rows 9–12 in table VIII.3 show the corresponding regulatory text sections related to Child Headform Test Area.

Similarly, “Adult Headform Test Area” in FMVSS No. 228 does not have an equivalent term in GTR 9. However,

an equivalent set of borders for restricting the testing is provided in S7.4.2 (see table VIII.2)

TABLE VIII.2

S7.4.2 of GTR 9

Selected impact points on the bonnet for the adult headform impactor shall be, at the time of first contact:

- (a) a minimum of 82.5 mm inside the defined side reference lines, and;
- (b) forward of the WAD2100 line, or, a minimum of 82.5 mm forward of the bonnet rear reference line, whichever is most forward at the point of measurement, and;
- (c) rearward of the WAD1700 line.

Rows 13–16 in table VIII.3 show the corresponding regulatory text sections related to Adult Headform Test Area.

Although there are terminology differences between FMVSS No. 228 and GTR 9, the regulatory text of this NPRM is essentially aligned with GTR 9. To the extent there are differences, the differences would enable the

proposed standard to meet Safety Act requirements. As discussed throughout this preamble, however, the NPRM’s regulatory text reflects the wording of the GTR to benchmark the GTR’s concepts and methods implemented as an FMVSS. NHTSA has requested comments on the pros and cons of

various aspects of the NPRM’s regulatory text, particularly with respect to the areas of the vehicle that would be subject to headform testing under the GTR’s wording, and has focused readers on ways NHTSA believes the regulatory text could possibly be enhanced to achieve more safety benefits in the U.S.

TABLE VIII.3—COMPARISON OF TERMS USED TO HOOD SURFACE AND TEST AREA IN FMVSS NO. 228 AND GTR 9

Row No.	FMVSS No. 228	GTR 9
1	Leading Edge Reference Line (S6.3.2)	Bonnet leading edge reference line (S3.5).
2	Side Reference Line (S6.3.3)	Side reference line (S3.24).
3	Rear Reference Line (S6.3.4)	Bonnet rear reference line (S3.6).
4	Hood Top (S6.5.1)	Bonnet Top (S3.7).
5	Hood Area (S6.5.2)	Combined child and adult headform test areas (S3.12 and S3.1).
6	Hood Area front border (S6.5.2(a))	Front reference line of the child headform test area (S3.15).
7	Hood Area side border (S6.5.2(b))	Side reference line of the child and adult headform test areas (S3.12 and S3.1).
8	Hood Area rear border (S6.5.2(c))	Rear reference line for adult headform (S3.23).
9	Child Headform Test Area (S6.5.3)	No equivalent term defined, but essentially dictated by S7.3.2.
10	Child Headform Test Area front border (S6.5.3(a)) = HIC Unlimited Margin of the Leading Edge Reference Line (S6.4.2).	No equivalent term defined, but essentially dictated by S7.3.2(c).
11	Child Headform Test Area side border (S6.5.3(b)) = HIC Unlimited Margin of the Side Edge Reference Line (S6.4.3).	No equivalent term defined, but essentially dictated by S7.3.2(a).
12	Child Headform Test Area rear border (S6.5.3(c))	No equivalent term defined, but essentially dictated by S7.3.2(b).
13	Adult Headform Test Area (S6.5.4)	No equivalent term defined, but essentially dictated by S7.4.2.
14	Adult Headform Test Area front border (S6.5.4(a))	No equivalent term defined, but essentially dictated by S7.4.2(c).
15	Adult Headform Test Area side border (S6.5.4(b)) = HIC Unlimited Margin of the Side Edge Reference Line (S6.4.3).	No equivalent term defined, but essentially dictated by S7.4.2(a).
16	Adult Headform Test Area rear border (S6.5.4(c)) = HIC Unlimited Margin of the Rear Reference Line (S6.4.1).	No equivalent term defined, but essentially dictated by S7.4.2(b).

*B. Amendment 3*

As early as 2011, in discussions at WP.29, the International Organization of Motor Vehicle Manufacturers (OICA)<sup>130</sup> suggested an amendment to the GTR that would have changed the existing GTR protocol as well as the method of determining the allotment of HIC1000 and HIC1700 Area (discussed above in section VII of this preamble).<sup>131</sup> This suggested proposal was then officially taken up by the Netherlands in November 2011.<sup>132</sup> The proposal was revised and listed at the 55th GRSP meeting (May 2014) as Amendment to Phase 1.<sup>133</sup> Action on this document was deferred for many years, until a 2021 version (Amendment 3) submitted by the Economic Commission for Europe was brought back up for discussion for a possible introduction into GTR 9.<sup>134</sup> NHTSA had concerns about the suggested amendment and did not support it in either the 2011 or 2021 form and the suggestion, to date, has not been adopted. Below we discuss the two main aspects of the proposal. The first significantly reduces the amount of test area that must conform to a test value with a HIC1000 limit. The second changes the way test target points are determined, which has the potential to shrink the amount of test area at the HIC Unlimited Margin of the Side Reference Line. We discuss these changes here and seek comment because domestic auto

manufacturers have recently contacted NHTSA to express support for Amendment 3.<sup>135</sup>

1. Change to the Amount of Area That Must Comply With HIC1000

One of the main changes proposed by Amendment 3 relates to how the *child headform test area* and *adult headform test area* are defined in GTR 9. Currently, the GTR 9 combined *adult headform test area* and *child headform test area* are equivalent to the FMVSS No. 228 Hood Area. Essentially, the new Amendment 3 definitions of *adult headform test area* and *child headform test area* would bring the areas described in the definitions into alignment with how the Child Headform Test Area and Adult Headform Test Area are defined in proposed FMVSS No. 228, as explained in section VI.C of this preamble, *i.e.*, these areas are defined as being within the 82.5 mm offset lines. However, GTR 9 at S5.2.3 maintains the requirement that two-thirds of the combined *adult headform test area* and *child headform test area* is required to have a HIC of 1000 or less. This test area is renamed the *bonnet top test area*. Thus, as a result of the Amendment 3 definitional changes, the amount of HIC1000 area would now be based on a smaller amount of area. NHTSA has not supported this change because it would reduce the stringency

of the GTR 9 by decreasing the amount of HIC1000 area and increasing the amount of HIC1700 area.

The agency analyzed a regulatory approach incorporating the aspect of Amendment 3 related to a reduction of the HIC1000 area. The PRIA discusses this approach as Alternative 1. This analysis includes a cost teardown study and assumes the costs associated with meeting the requirements are similar for a regulatory alternative incorporating Amendment 3 and the proposed rule. The details of this analysis can be found in the PRIA for this NPRM. The equivalent life saved (ELS) estimate and cost per ELS of Amendment 3 compared to the proposed rule are shown in table VIII.4 below. The monetized benefits and net benefits of Amendment 3 compared to the proposed rule are shown in table VIII.5. In comparison to the proposed rule, the equivalent lives saved under a regulatory alternative incorporating Amendment 3 are approximately 59% of that under the proposed rule. Under the assumption that the costs are the same for both the regulatory alternative and proposed rule, the cost per ELS under Amendment 3 is nearly double that of the proposed rule. Lastly, net benefits under Amendment 3 are approximately 55% of the benefits of the proposed rule.

TABLE VIII.4—COMPARISON OF COST PER EQUIVALENT LIFE SAVED (ELS)  
[Millions]

Regulatory approach	Cost		Equivalent lives saved		Cost per equivalent life saved	
	3%	7%	3%	7%	3%	7%
GTR 9 Amendment 3 (PRIA Alternative #1) .....	\$60.43	48.94	32.28	26.20	\$1.87	\$1.87
Proposed Rule .....	60.43	48.94	54.87	44.46	1.1.0	1.10

TABLE VIII.5—COMPARISON OF MONETIZED AND NET BENEFITS FOR PROPOSED RULE AND AMENDMENT 3  
[Millions]

Regulatory option	Monetized benefits		Net benefits	
	3%	7%	3%	7%
GTR 9 Amendment 3 (PRIA Alternative #1) .....	\$384.51	\$312.09	\$324.08	\$263.15
Proposed Rule .....	653.76	529.74	593.33	480.79

<sup>130</sup> OICA was actively involved in the working group meetings developing GTR 9. OICA’s website states that its members represent the global auto industry. It is known as the “Organisation Internationale des Constructeurs d’Automobiles (OICA).” [www.oica.net](http://www.oica.net).

<sup>131</sup> Proposal of Amendments to GTR 9 (Pedestrian safety), WP.29 Informal document GRSP-49-09, 49th GRSP Meeting, 16–20 May 2011. <https://unece.org/DAM/trans/doc/2011/wp29grsp/GRSP-49-09e.pdf>.

<sup>132</sup> ECE/TRANS/WP.29/2011/148, <https://unece.org/DAM/trans/doc/2011/wp29/ECE-TRANS-WP29-2011-148e.pdf>.

<sup>133</sup> ECE/TRANS/WP.29/GRSP/2014/5, <https://unece.org/DAM/trans/doc/2014/wp29grsp/ECE-TRANS-WP29-GRSP-2014-05e.pdf>.

<sup>134</sup> TWSG-01-04—ECE-TRANS-WP29-2021-053e, <https://unece.org/sites/default/files/2021-02/ECE-TRANS-WP29-2021-053e.pdf>.

<sup>135</sup> In advance of the publication of this NPRM, NHTSA received a letter from the Alliance for Automotive Innovation (Innovators) restating support of the interpretation of the GTR 9 that aligns with the proposed GTR amendment. (The letter can be found in the docket for this NPRM.) Additionally, in December 2022, NHTSA and the Innovators met at the latter’s request to discuss the same topic. An ex parte memo documenting this meeting can also be found in the docket.

## 2. Change From 3D Method to 2D Targeting Method

The second significant change proposed by Amendment 3 is related to the targeting method to determine the point on the test surface that is assigned the HIC value from the impact test. As we stated previously, NHTSA's proposed method of targeting areas on the hood and assigning HIC values through the first point of contact is consistent with GTR 9, and we refer to it as the "3D Method." NHTSA believes GTR 9 is sufficiently objective using the 3D Method and that Amendment 3 would not improve the objectivity of the regulation.

We refer to the Amendment 3 suggested method as the "2D Measuring Point Method" or, for simplicity, the "2D Method" in the discussion below. Under the 2D Method, the contact point between the mid-sagittal plane of the headform and the hood, referred to as the "measure point" in the GTR amendment, serves to define whether HIC1000 or HIC1700 applies to the particular impact. The "2D measure point" is established prior to a launch and the HIC limit is assigned to that point. Proponents of the amendment argued that the 2D Method improved objectivity over the 3D Method because, with the 3D Method, the first point of

contact may be related to multiple lateral headform launch positions.

To illustrate, figure VIII.1 is a top down and rearward-looking view of a hood with a sharp bend in the lateral plane. Because of this sharp transition in the hood profile, it is possible for the headform impactor to contact the same or nearly the same point (first point of contact, which in this case is the sharp transition point) for different launch positions of the headform. However, both the 2D and 3D Methods will have the same range of headform launch positions that would result in the first point of contact at the sharp transition.

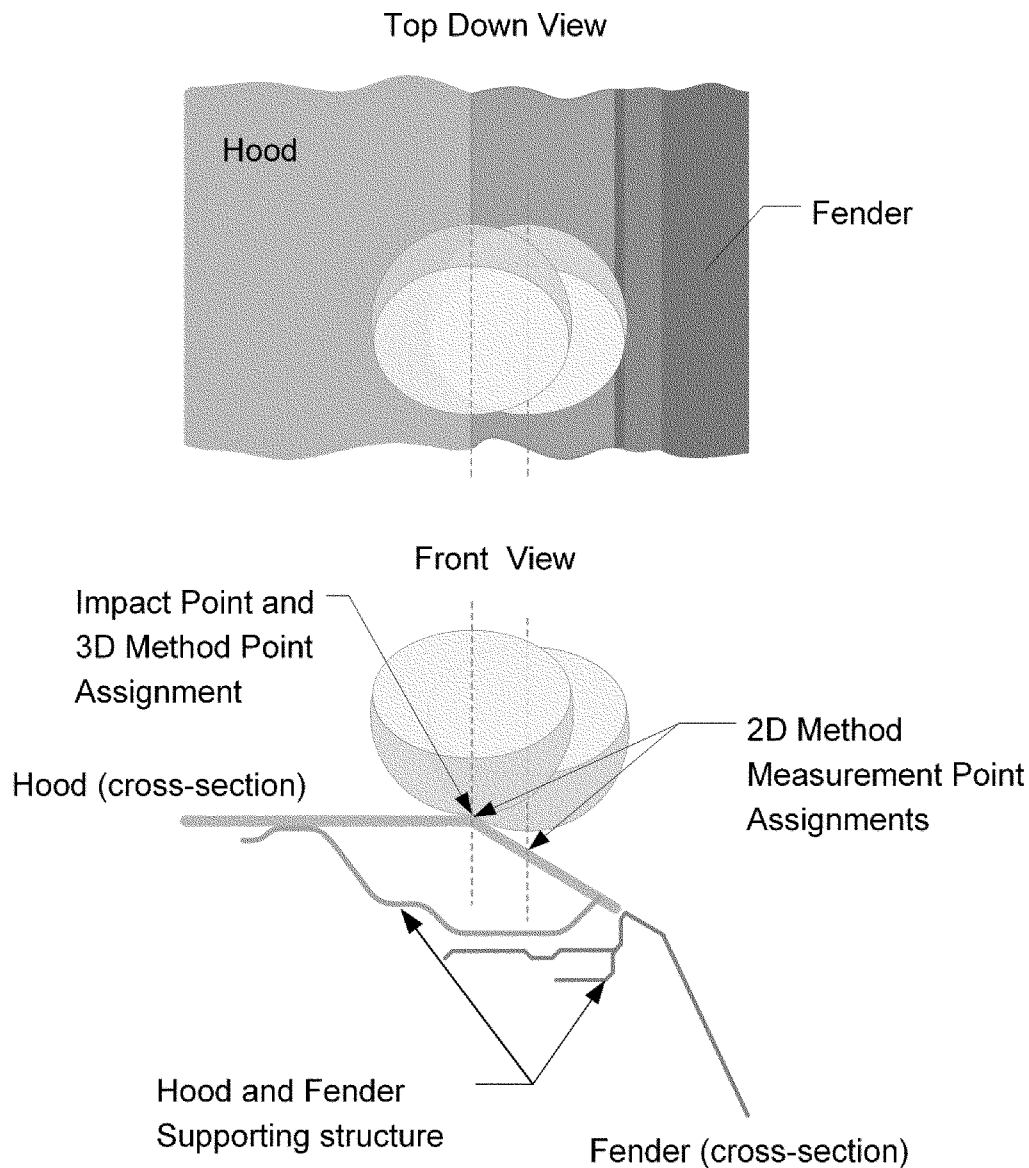

**Figure VIII.1. Range of test positions that impact the same point on a sharp transition.**

As explained above, in the 2D Method, the 2D measure point on the hood is established prior to a launch and the pre-test position of the headform is determined by aligning the mid-sagittal plane of the headform to that point. Although proponents of the 2D Method argued that this method of pre-determining the test point on the hood and assigning the test results to that point improves objectivity of the

test, NHTSA disagrees. For the hood profile shown in figure VIII.1, the test results for a range of 2D measure points will be associated with the headform impacting the same hood location (the sharp transition). NHTSA believes this situation creates ambiguity rather than improves objectivity because in some instances, the HIC assignment for a point might not be related to the point being impacted. As illustrated in figure

VIII.1, the HIC values were assigned to points on the slope, from an impact location further up the slope. In contrast, the 3D Method is more representative of real-world impacts as it assigns each test result to its corresponding location of impact (first contact point) (see figure VIII.2).

BILLING CODE 4910-59-P

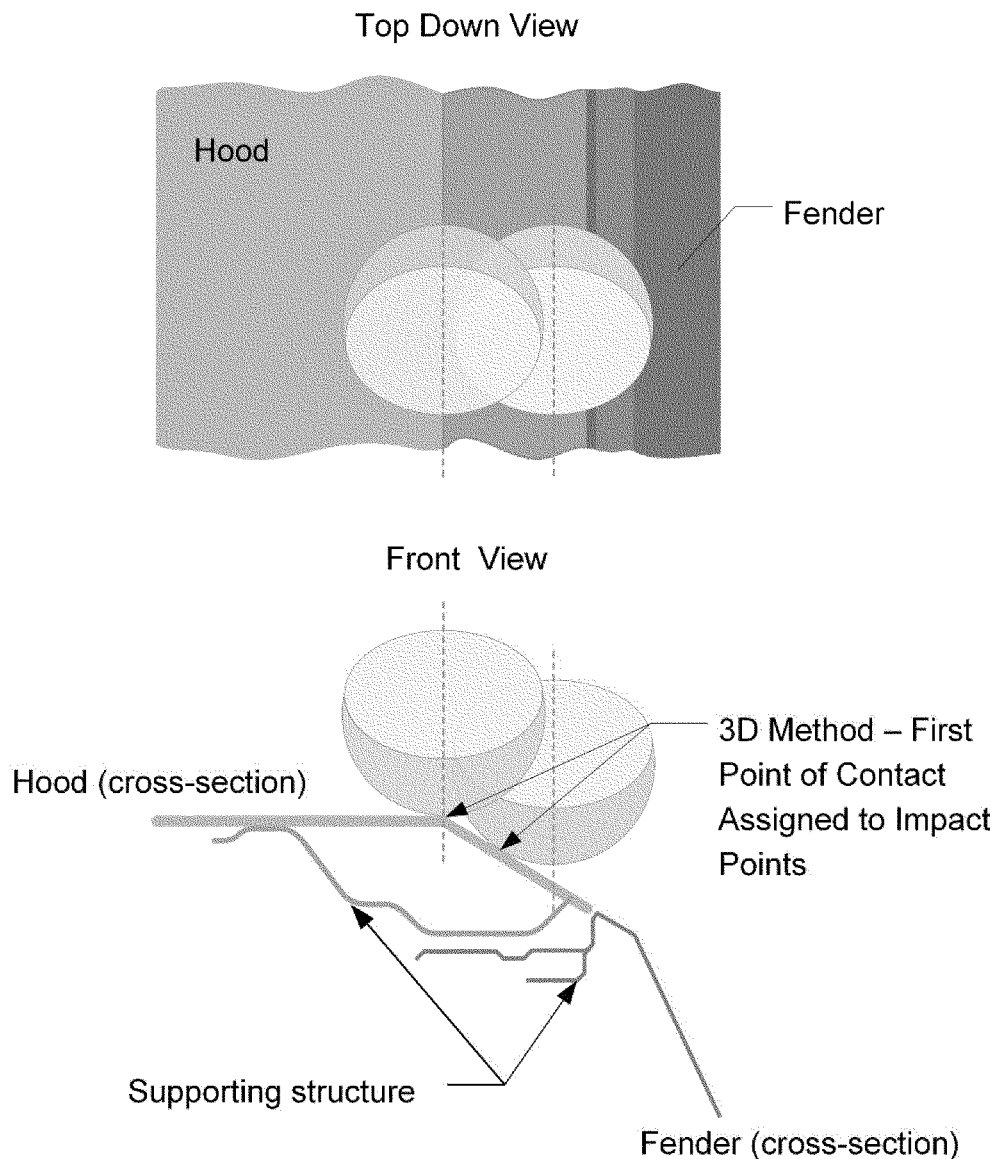

**Figure VIII.2. – 3D Method Assigns HIC Value to Actual Contact Location.**

BILLING CODE 4910-59-C

Additionally, in the 3D Method both the lateral pre-test position of the headform as well as the first point of contact are known, which enables NHTSA to fully define each test in a

compliance proceeding.<sup>136</sup> This makes each test objective and highly

<sup>136</sup> Manufacturers must certify compliance with any first point of contact to the require HIC limit for that location, irrespective of the launch position(s) of the of the headform.

repeatable. Thus, we see no reason to favor the 2D Method over the 3D Method based on claims of improved objectivity.

NHTSA is also concerned about the safety implications of the 2D Method.

The 2D Method can result in a smaller test area, particularly on hoods that have a downward slope at the sides of the vehicle (See figure VIII.5). In this figure, the more outboard headform indicates valid positions that would be tested by the 3D Method. Conversely, the valid positions tested by the 2D Method are shown by the more inboard position, where the mid-sagittal plane of the headform aligns with the HIC Unlimited Margin. As can be seen, the methods used result in different test area, with the 2D Method decreasing the size of the area tested. In our own testing of six vehicles of model year 2011 or later, we observed that the 2D Method moved the impact point further inboard for five of the six vehicles we tested (and by as much as 46 mm for

one vehicle). As expected, because hood edges are reinforced, HIC scores were lower when the headform was further inboard. Those data are consistent with NHTSA testing that has shown that these perimeter locations may produce higher HIC levels compared to the rest of the hood.<sup>137</sup>

Previous real-world studies have shown that many pedestrian head impacts take place along the hood-fender junction. One study found the most severe head injuries concentrated towards the outer third of the hood.<sup>138</sup>

<sup>137</sup> Details of these tests can be found in: Suntay B and Stammen, JA (2014), Vehicle hood testing to estimate pedestrian headform reproducibility, GTR No. 9 test procedural issues, and U.S. fleet performance

<sup>138</sup> Koetje B and Grabowski J. A Methodology for the Geometric Standardization of Vehicle Hoods to

As far back as our 1990 era standards development effort, we observed an incidence rate of about 20% along the sides.<sup>139</sup> NHTSA is not aware of research indicating that this rate has gotten or will get lower. Thus, NHTSA believes the reduction in safety using the 2D Method could be significant and has decided not to include the method in this NPRM.

**BILLING CODE 4910-59-P**

Compare Real-World Pedestrian Crash; *Annals of Advances in Automotive Medicine*. 2008; 52: 193–198.

<sup>139</sup> An analysis of the potential costs and benefits of pedestrian head-to-hood impact protection, NHTSA Office of Regulatory Analysis, NHTSA Docket 91–43, Notice 1, document No. 3, January 1990. A copy of this document is in the docket for this NPRM.

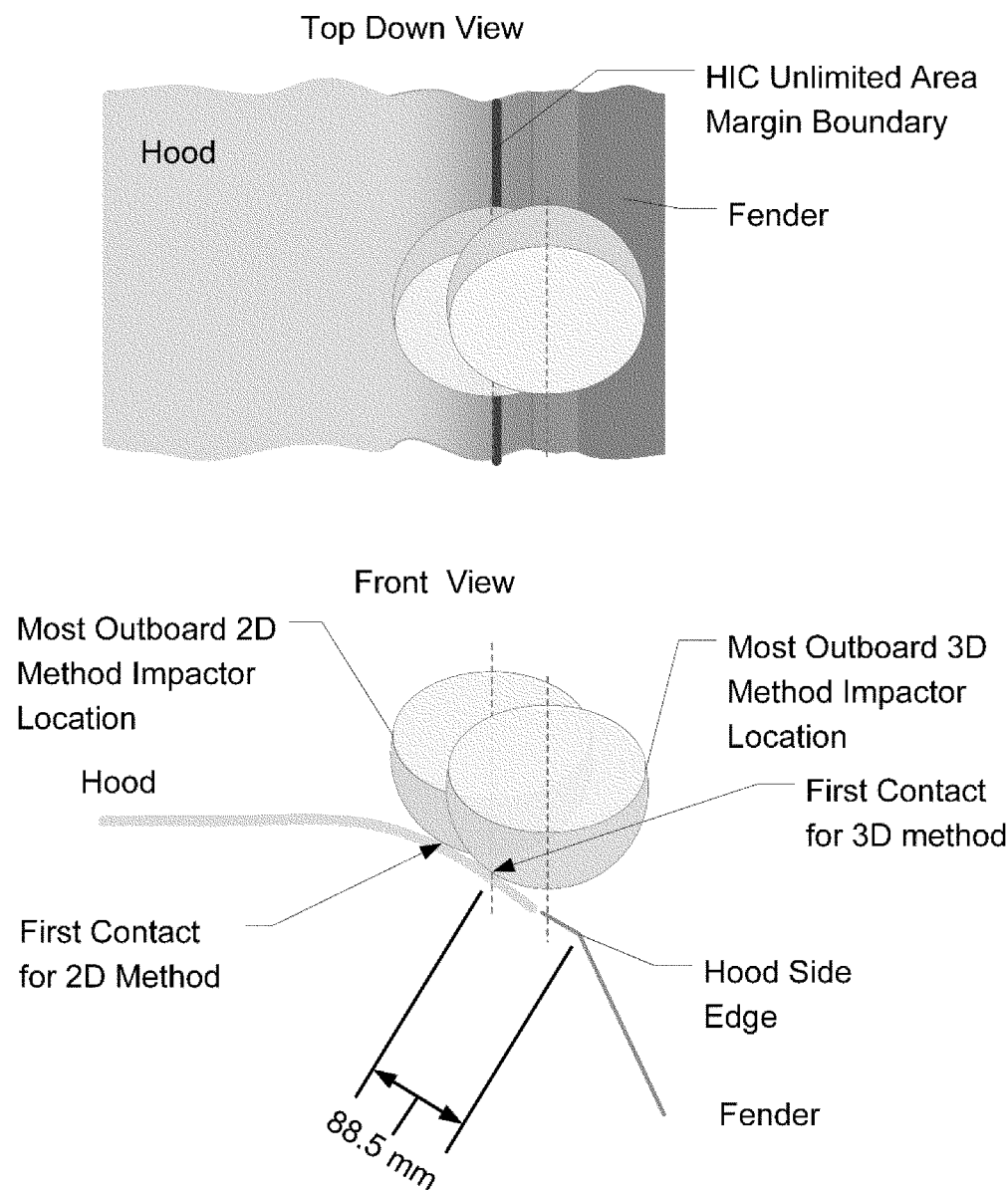

**Figure VIII.5. 3D Method allows for a more outboard test position than the 2D Method.**

BILLING CODE 4910-59-C

## IX. Headform Characteristics

### A. General

The proposed headform impactors are hemispherical and completely featureless. The mass of the child headform is 3.5 kg and that of the adult headform is 4.5 kg. During the development of the GTR, researchers attempted to determine the appropriate “effective mass” of the headforms to account for the influence of the neck/torso mass on the force the head would impart to the hood. The researchers determined that, averaged over a variety of vehicle shapes, the “effective mass” was comparable to the head mass

itself.<sup>140</sup> Thus the masses selected represent both the “effective masses” and actual masses of an average 6-year-old child and a 50th percentile adult male. The mass for a 5th percentile female head is 3.7 kg.<sup>141</sup> Using

<sup>140</sup> Mizuno, Y. Summary of IHRA Pedestrian Safety WG Activities (2005)—Proposed Test Methods to Evaluate Pedestrian Protection Afforded by Passenger Cars. ESV 05-0138.

<sup>141</sup> Schneider, L.W., Robbins, D.H., Pflüg, M.A., and Snyder, R.G. (1983). Anthropometry of Motor Vehicle Occupants: Development of anthropometrically based design specifications for an advanced adult anthropomorphic dummy family, Volume 1. Final report DOT-HS-806-715. U.S. Department of Transportation, National Highway Traffic Safety Administration, Washington, DC.

anthropometric data of adult female head circumference, we can estimate the female head mass percentile for both the child and adult headform.<sup>142</sup> The 3.5 kg mass of the child headform represents a 1st percentile female head mass and the 4.5 kg mass of the adult headform represents a 64th percentile female head mass. Thus, these headform masses represent a range of pedestrian sizes from small children, 64 percent of all female adults, and up to the average adult male. The effective mass is the

<sup>142</sup> Based on 2007–2010 NHANES from <http://tools.openlab.psu.edu/tools/explorer.php>. Head mass is assumed to be proportional to the volume of a sphere with a circumference equal to the measured head circumference.

estimated head mass that is applied to the hood by a struck pedestrian and includes an allowance for the body force acting through the neck during the head impact. Effective head mass has been estimated via laboratory tests with pedestrian dummies and postmortem human subjects (PMHS), and through mathematical modelling of pedestrian collisions.

The diameter of the proposed headforms is 165 mm for both the child and adult headforms. The average cross-sectional axis of a 6-year-old child head in the transverse plane at its forehead is about 165 mm (circumference is 523 mm according to Irwin, 1997).<sup>143</sup> For an adult, the head is more elliptical at the forehead cross-section and 165 mm falls between the breadth (154 mm) and depth (197 mm) of a 50th percentile male.

Each headform would have three parts: an aluminum hemisphere, a synthetic covering, and an end plate. The main hemisphere of each headform is hollowed out to eliminate internal corners and mitigate low-frequency resonance. The lighter hemisphere has a deeper cavity to achieve the same 165 mm diameter as the heavier, adult headform. Both the proposed child and adult headforms have vinyl coverings and the headforms and coverings together are designed to achieve a specific system response.

The proposed headform end plates are bolted onto the hemisphere and hold the synthetic coverings in place. This NPRM specifies the material and dimensions of the end plates. A triaxial arrangement of accelerometers is mounted on the inner surface of each end plate such that they are located at the centroid of the headforms.

Each combination of hemisphere, synthetic covering, and end plate (including accelerometers and their mount blocks) would assure that the center of gravity of the complete headform is coincident with the geometric center of the spheroid (*i.e.*, the centroid) while attaining a moment of inertia that is representative of a 6-year-old child (for the child headform) and a 50th percentile adult male (for the adult headform).

A complete set of drawings for each headform is provided as part of the regulatory text of proposed FMVSS No. 228 in figures 13–27. The drawings are, to NHTSA's knowledge, consistent with the current production of two known manufacturers of headforms that the agency has used in testing and

evaluation described in section IX.C.<sup>144</sup> In some cases, dimensions have been purposefully made “reference” dimensions to facilitate flexibility in producing headforms such as those evaluated headforms. GTR 9 does not provide this level of specificity and only provides headform schematics such as are included in figures 11 and 12 in the proposed regulatory text. Contrary to that approach, the agency believes there is benefit to providing more detailed drawing dimensions, as we have done in figures 13–27. These detailed drawings should allow any entity wishing to produce a headform that can be used in FMVSS No. 228 to simply meet the provided dimensions. However, consistent with GTR 9, the notes provided on the headform drawings specify that headform dimensions may be modified as long as a set of specifications of the drawings is met. These specifications pertain to the impactor mass, diameter, skin material and thickness, center of gravity, moment of inertia, acceleromenter mounting, acceleromenter damping, qualification limits and natural frequency. The agency requests comment on the approach taken with the headform drawings. Should the agency take an even more prescriptive approach than has been proposed or should it take a less prescriptive approach similar to GTR 9?

### B. Qualification Limits

This NPRM proposes a set of pre-test qualification limits to ensure the headforms are functioning properly.<sup>145</sup> The qualification tests are also intended to assure that the impact responses of the headforms are uniform. NHTSA's regulation for anthropomorphic test devices (49 CFR part 572) specifies qualification tests and limits for all anthropomorphic test devices (ATDs) used in the FMVSSs.

The proposed qualification tests are headform drop tests. The proposed qualification requirements are based on the peak resultant acceleration measured within the headform in the

<sup>144</sup> Humanetics Corp., Farmington Hills MI, formally FTSS, and Cellbond, Huntingdon, United Kingdom.

<sup>145</sup> “Qualification limits” set parameters to ensure test devices are functioning properly. Test devices (*e.g.*, headforms) are subjected to a prescribed test protocol and are deemed acceptable if they provide measurements within the qualification limit. If the qualification limits are not met, the agency will adjust the device (headform) until the qualification limits are met or discard the device (headform), deeming it insufficiently reliable for use in a compliance test. A “narrowing” of the qualification limit means that less variation in the performance of the test devices at issue would be acceptable to NHTSA compared to a qualification limit that had a wider tolerance as to acceptable performance.

qualification test. The test apparatus is shown in figure 12 of proposed FMVSS No. 228, *infra*.

The proposed apparatus and procedure have been adapted from those used to qualify the headforms of ATDs specified in 49 CFR part 572. The proposed test for the child headform was adapted from the test used for the Hybrid III 6-year-old child dummy (part 572, subpart N), while the proposed test for the adult headform was adapted from the test for the Hybrid III 50th percentile adult male (part 572, subpart E). In the proposed tests, the headform is suspended at a height of 376 mm and a drop angle of 50 degrees and 65 degrees, with respect to the vertical, for the child and adult headforms, respectively.

For each pedestrian headform, there would be qualification tests consisting of three head drops with the headform rotated 120° around its symmetrical axis after each drop. We propose that the resultant acceleration of the child headform must fall between 245–300 g's for drops at each rotation. For the adult headform, the proposed limits are 225–275 g's. The limits are the same as those currently in part 572 for headform qualification of the Hybrid III 6-year-old child and Hybrid III 50th percentile adult male test dummies. These G-limits represent ±10 percent of the midpoint of data obtained from headform drops in tests conducted for the Hybrid III 6-year-old and 50th percentile adult male dummies. In addition, we propose requirements for off-axis sensitivity and a unimodal response, as well as a protocol to clean the headform prior to qualification testing to improve repeatability. These factors are in addition to GTR 9 specifications and are based on NHTSA's years of testing and qualifying headforms. They would be consistent with other part 572 headform requirements.

### C. Repeatability and Reproducibility

The headforms have been shown to produce repeatable and reproducible results. Repeatability is defined as the similarity of responses from a single headform when subjected to multiple repeats of a given test condition. Reproducibility is defined as the similarity of test responses from multiple headforms when subjected to multiple repeats of a given test condition. NHTSA assessed the repeatability and reproducibility (R&R) of the headforms in qualification drop tests and actual hood tests.

#### 1. Headform Drop Tests

In headform drop tests, we assessed the R&R of child and adult headforms

<sup>143</sup> Irwin A and Mertz HJ (1997), Biomechanical basis for the CRABI and Hybrid III child dummies, 41st Stapp Car Crash Conference, 1997.

manufactured by two different manufacturers, Cellbond and FTSS.<sup>146</sup> As part of this assessment, we also varied the type of accelerometer installed within the headform. We ran two sets of qualification tests with the Cellbond headforms: one with damped accelerometers and one with undamped accelerometers. One set of tests was run with the FTSS headforms, fitted with

undamped accelerometers. All acceleration responses were filtered at Channel Filter Class (CFC) 1000. The responses are summarized in table IX.1, including averages, standard deviations, and percent coefficients of variation (%CV). The %CV is computed by dividing the standard deviation by the average (and multiplying the result by 100 percent). The results are similar for

both headform manufacturers and for both accelerometer types. Typically, NHTSA strives for a %CV of less than 5 percent, so the low %CV observed in our tests indicates a high degree of repeatability and reproducibility by our measure and is well within an acceptable interval.

TABLE IX.1—QUALIFICATION DROP TESTS: PEAK RESULTANT ACCELERATION (AND HIC SCORES) OF HEADFORMS

Headform (compliance interval, g)	Statistical measure	Peak acceleration, g (HIC score in parentheses)			
		Cellbond (damped)	Cellbond (undamped)	FTSS (undamped)	Combined
Child (245–300)	Average	257 (871)	258 (851)	262 (904)	259 (876)
	StdDev	4.36 (3.00)	1.00 (19.35)	9.07 (46.32)	5.62 (34.21)
	%CV	1.7% (0.3%)	0.4% (2.3%)	3.5% (5.1%)	2.2% (3.9%)
Adult (225–275)	Average	238 (779)	237 (758)	235 (766)	237 (768)
	StdDev	5.57 (16.82)	3.06 (17.58)	1.15 (11.36)	3.57 (16.26)
	%CV	2.3% (2.2%)	1.3% (2.3%)	0.5% (1.5%)	1.5% (2.1%)

The headforms were dropped from a height of 376 mm, which is the height specified in GTR 9 and the height used in other part 572 headform qualification tests. However, we are considering raising the drop height. Typically, in NHTSA’s practice an ATD qualification procedure exercises the ATD near the pass/fail reference measure. In this case, the HIC scores obtained from the 376 mm drop are slightly below the HIC1000 limit proposed for the pedestrian headform requirement, and well below the HIC1700 requirement. (Average HIC produced by the 376 mm drop are 876 for the child headform, and 768 for the adult headform). Therefore, we request comments on raising the drop height to a height that would produce HIC scores somewhere between 1000 and 1700.

We also request comments on changing the qualification bounds of 245–300 g’s for the child headform and 225–275 g’s for the adult headform. For other ATDs used in FMVSSs, we generally set qualification bounds by examining data from multiple test labs, several ATDs, and ATDs built by different manufacturers. In other words,

the qualification bounds are derived from the qualification data, not set *a priori*, with a goal to set them at no greater than 10 percent of the mean.

We understand that the qualification bounds of GTR 9 were set *a priori*, by using the qualification limits of part 572 as a basis for the bounds. While this would be acceptable given that the part 572 bounds have worked satisfactorily historically, our results suggest that those pre-existing headform qualification limits could be narrowed for both of the pedestrian headforms. The part 572 headform qualification limits were developed for the Hybrid III head, but the hemispherical headforms specified in this NPRM are much more geometrically uniform. For the pedestrian headforms, the acceptance bounds of ±25 g’s (for the adult headform) and ±27.5 g’s (for the child headform) are both derived using the 10 percent approach. In part 572, NHTSA has generally sought to set qualification limits for a test device within ±10% of a nominal target, usually the mean response from all relevant data available about a test device gathered from agency

research, commenters’ submissions and other means. The ±10% margin is considered wide enough to account for normal variations in response and laboratory differences, and narrow enough to ensure consistent and repeatable measurements in standardized testing. However, both sets of bounds represent well over three standard deviations from the mean based on the test data shown in table IX.1. From a probabilistic standpoint, three standard deviations constitute an unusually wide bound.

Since the publication of the headform evaluation report, NHTSA Vehicle Research and Test Center (VRTC) has continued to conduct many more headform qualification tests to support vehicle impact testing. This updated dataset provides a significantly greater number of samples from a much larger number of headforms. These data can be used to better determine whether the current GTR 9 qualification bounds are appropriate and sufficient, rather than using only the data from table IX.1. Table IX.2 summarizes this updated dataset.

TABLE IX.2—UPDATED NHTSA DATA FROM HEADFORM QUALIFICATION TESTS

[Peak resultant acceleration]

Headform orientation	Child headform (12 headforms subjected to 60 total tests)			Adult headform (12 headforms subjected to 60 total tests)		
	Average	Standard deviation	%CV	Average	Standard deviation	%CV
0 deg	275	16.7	6.1	252	12.1	4.8
120 deg	272	14.7	5.4	251	13.0	5.2

<sup>146</sup> Suntay B and Stammen, JA (August 2018), Vehicle hood testing to estimate pedestrian

headform reproducibility, GTR 9 test procedural

issues, and U.S. fleet performance. Docket NHTSA–2008–0145–0014.



TABLE IX.2—UPDATED NHTSA DATA FROM HEADFORM QUALIFICATION TESTS—Continued  
[Peak resultant acceleration]

Headform orientation	Child headform (12 headforms subjected to 60 total tests)			Adult headform (12 headforms subjected to 60 total tests)		
	Average	Standard deviation	%CV	Average	Standard deviation	%CV
240 deg .....	274	16.6	6.1	250	13.0	5.2
All .....	273	15.8	5.8	252	12.1	4.8

The average responses are almost exactly in the middle of the GTR specification for a large number of headforms and tests, and the current GTR 9 tolerance of ±10% closely approximates two standard deviations for both headforms (slightly less for the child headform and slightly more for the adult headform). Based on this information, the FMVSS No. 228 proposal retains the GTR specification rather than providing an alternative specification unique to NHTSA.

While the data shown in table IX.2 constitute a substantial set of 120 data points from 24 different headforms, our tests were conducted at a single laboratory (NHTSA’s Vehicle Research and Test Center) with headforms from three headform manufacturers.<sup>147</sup> Our data may not reflect normal variations that accrue when a large set of headforms are tested across various laboratories. There may be unknown variability associated with different labs, operators, headforms, and other typical variances such as temperature and humidity, that may not be present in our dataset.

Thus, although we have used the conservatively wide bounds from part 572 in the proposed regulatory text for this NPRM, we seek qualification data from commenters. We will examine all qualification data provided and anticipate that, when new qualification data are combined with our current set of data, the bounds could be tightened, such as to one standard deviation or less. For a final rule, our intent is to set bound widths as narrowly as is reasonable to control variability to the extent possible.

We note that a comparison of qualification results for Cellbond vs. FTSS headforms used in our research programs did show some differences. In qualification tests, Cellbond and FTSS headforms were essentially equivalent in terms of the peak acceleration they measured, but HIC scores differed between the FTSS and Cellbond child headform by about 5%. Also, a phase difference in the signal response appears evident, with the Cellbond units producing peaks in acceleration that occur about 0.5 ms earlier in both the adult and child headforms. However, as discussed below, the FTSS and Cellbond headforms are essentially equivalent when considering the HIC scores produced by hood impacts.

2. Headform Performance in Hood Testing

We also assessed the performance of the headforms in tests on actual hoods. The Cellbond and FTSS headforms were evaluated on three vehicle models: the 2010 Kia Forte, the 2010 Buick LaCrosse, and the 2010 Acura MDX. We also used different types of accelerometers to assess the effect of damped versus undamped models. (Although these vehicle models are now more than a decade old, the results and conclusions are still valid as they relate to how the headforms performed relative to an actual hood. The assessment was done in the 2012–2014 timeframe on new hoods. The vehicles were selected to provide a cross-section of vehicle manufacturers, vehicle classes and hood contours.)

We selected three test points in areas on the hood where HIC was expected to exceed HIC1000 and approach HIC1700.

In other words, we exercised the headforms near the proposed HIC performance thresholds. The three points were: an inboard point along the WAD1000 border (near the front edge of the hood); a point just inside the HIC Unlimited Margin of the Side Reference Line (near the fender); and an inboard point near the Rear Reference Line (near the rear edge of the hood).

We conducted tests at all three points with one headform brand/accelerometer combination before switching to another. Each time a headform switch was made, a new hood was installed. For each vehicle, the impact points were tested in the same order. The order of headform use was: (1) FTSS (undamped accelerometers); (2) Cellbond (damped accelerometers); and, (3) FTSS (damped accelerometers). The hoods of the Forte and the LaCrosse were sufficiently short that only child headforms were used. Child and adult headforms were used on the Acura MDX.

Qualification tests were performed on each headform before and after the test series to ascertain the accuracy of their measurements. The headforms met all of the qualification response requirements, both before and after the tests.

We note that when comparing tests at the same test point on different samples of the same hood, the data also represent differences that may exist due to production variability of the hood itself. Without extensive testing of many copies of a particular hood, it was not possible for NHTSA to separate this production variability from that of the headform and test procedure. HIC results are presented table IX.3 for the three vehicles tested.

BILLING CODE 4910–59–P

<sup>147</sup> Table IX.1 contains headform data from two manufacturers, while table IX.2 contains headform data from three manufacturers.

**Table IX.3. HIC scores for headform-to-hood impacts on three vehicles.**

Vehicle	1st Contact Point		Test Order	HIC15	Headform	Mfg	Accel. Type	Test location (Comment)
	WAD, mm	Distance from CL, mm						
2010 Buick Lacrosse	1000	220	1	1026	Child	FTSS	Undamped	WAD1000 border
			2	1053	Child	Cellbond	Damped	
			3	1025	Child	FTSS	Damped	
			Average	1034.7				
			StdDev	15.9				
		%CV	1.54%					
	1289	769	1	1602	Child	FTSS	Undamped	Side no-test border
			2	1578	Child	Cellbond	Damped	
			3	1482	Child	FTSS	Damped	
			Average	1554.0				
			StdDev	63.5				
		%CV	4.09%					
1690	-369	1	686	Child	FTSS	Undamped	Rear no-test border	
		2	650	Child	Cellbond	Damped		
		3	636	Child	FTSS	Damped		
		Average	657.3					
		StdDev	25.8					
	%CV	3.92%						
2010 Kia Forte	1000	220	1	626	Child	FTSS	Undamped	WAD1000 border
			2	524	Child	Cellbond	Damped	
			3	506	Child	FTSS	Damped	
			Average	552.0				
			StdDev	64.7				
		%CV	11.72%					
	1130	-740	1	1587	Child	FTSS	Undamped	Side no-test border
			2	1537	Child	Cellbond	Damped	
			3	1540	Child	FTSS	Damped	
			Average	1554.7				
			StdDev	28.0				
		%CV	1.80%					
1586	-370	1	597	Child	FTSS	Undamped	Rear no-test border	
		2	486	Child	Cellbond	Damped		
		3	516	Child	FTSS	Damped		
		Average	533.0					
		StdDev	57.4					
	%CV	10.77%						
2010 Acura MDX	1120	183	1	1283	Child	FTSS	Undamped	BLE no-test border (spot weld separation lowers HIC on last test)
			2	1324	Child	Cellbond	Damped	
			3	969	Child	FTSS	Damped	
			Average	1192.0				
			StdDev	194.2				
		%CV	16.29%					
	1755	-740	1	1696	Adult	FTSS	Undamped	Side no-test border.
			2	1366	Adult	Cellbond	Damped	
			3	1519	Adult	FTSS	Damped	
			Average	1527.0				
			StdDev	165.1				
		%CV	10.82%					
1700	174	1	503	Adult	FTSS	Undamped	WAD1700 border (fender deformation before last test lowers HIC)	
		2	603	Adult	Cellbond	Damped		
		3	505	Adult	FTSS	Damped		
		Average	537.0					
		StdDev	57.2					
	%CV	10.65%						

**BILLING CODE 4910-59-C**

*2010 Buick Lacrosse.* For the Buick LaCrosse, the HIC variability was less than 10 percent at all three points. Notably, tests at two of the points produced HIC scores near the HIC1000 and HIC1700 thresholds, and the third produced an average HIC score near 650. This demonstrates a high level of repeatability when test results are near

the pass-fail compliance thresholds. It also demonstrates that the various headform and accelerometer combinations performed in a functionally equivalent manner.

*2010 Kia Forte.* For the Kia Forte, one test point, near the fender, produced HIC scores near a compliance threshold. HIC scores were just below the HIC1700

threshold, and the variability was very low—less than 4 percent.

At the two other points (near the WAD1000 border and the rear HIC Unlimited Margin), variability was over 10 percent. However, at both points the HIC scores were well below HIC1000. In addition, we note that for lower HIC values, a similar absolute difference in HIC value represents a higher

percentage of the HIC level. In other words, the CV% is artificially high because the denominator (average HIC) is low—not so much that the variability in repeated impacts is excessive.

*2010 Acura MDX.* At each of the three test points, HIC variability was 10 percent or higher. However, we believe that factors may have increased the variability. During the tests at the WAD1700 border (and near to the hood hinge), we observed fender deformation that took place during the course of testing. (Use of the heavier adult headform may have caused the deformation.) The damage occurred within the body structure, not on the hood itself, and was not repaired or replaced between tests. The deformation could have lowered the HIC of a subsequent test and contributed to the variability in HIC scores.

Also, in the test with the FTSS-damped headform run near the HIC Unlimited Margin of the Leading Edge Reference Line, there was a spot weld separation within the hood structure where an inner layer of sheet metal was mated to the bottom side of the outer layer. The test had a HIC of 969. No separation was observed in the other two tests, which had more comparable HIC scores (1283 and 1324).<sup>148</sup>

### 3. Reproducibility in Hood Testing

The results of the hood testing program also demonstrated good reproducibility of the headforms' measurement of HIC.<sup>149</sup> The results in table IX.3 show that FTSS and Cellbond headforms are essentially equivalent when considering the HIC scores produced by hood impacts in which test conditions were otherwise identical.

We analyzed HIC scores produced by child headforms fitted with Endevco model 7264G damped accelerometers. For the six pairs of tests considered, the variability was no greater than 7 percent in any of the paired tests. Also, there was no apparent trend in which one headform produced higher HIC scores than the other. For four of the test points, the lowest HIC score was produced by the FTSS unit. In the other two, the Cellbond scores were lowest. We did observe that the FTSS child unit had relatively high variability for HIC (Standard Deviation = 46), but not peak acceleration. Adult headforms had much lower variability for all conditions.

<sup>148</sup> We do not believe the 2010 Acura MDX was designed in accordance with GTR 9 requirements. The 2010 Acura MDX was produced in Canada, and to our knowledge, was not sold in Europe.

<sup>149</sup> This conclusion is based only on tests on the Kia and Buick since variability was observed in the way the hood of the Acura MDX deformed.

## 4. Instrumentation

### Proposal for Damped Accelerometers

This NPRM proposes a specification for damped accelerometers in the headforms. Although the GTR does not refer specifically to damped<sup>150</sup> accelerometers, the preamble to the GTR recommends damped accelerometers based on findings from a 2002 research program using 2001 headform data collected for the Japan New Car Assessment Program (J-NCAP). In headform tests with undamped accelerometers, abnormal signals that produced high HIC values were observed in windshield impacts<sup>151</sup> and occasionally in hood impacts. The cause of the abnormality was attributed to vibrations that arose when the impulse of the impact was near the resonant frequency of the accelerometer.<sup>152 153</sup>

NHTSA's testing has been with undamped accelerometers. The testing and findings are described in section IX.C.5.c, below. We did not observe any signal irregularities of the sort observed in the J-NCAP study. We did observe a difference in peak measurements depending on the type of accelerometer (they were generally lower with damped units). In vehicle tests, these sharp pulses occur when hard metal-to-metal contacts or mechanical fractures take place. If an accelerometer is attached directly to a vehicle structure (such as the frame rail), the sharp pulse can often saturate the measurement system. However, ATDs such as crash test dummies are designed to avoid internal mechanical fractures or metal-to-metal contact that could produce sharp pulses. Therefore, undamped accelerometers are typically specified for ATDs used in FMVSSs.<sup>154</sup>

Nonetheless, although we saw no resonance issues in our tests with ATD heads fitted with the undamped units, we propose damped accelerometers for the pedestrian headforms. We envision using the same headforms in NCAP where the test protocol includes

<sup>150</sup> In general, damped accelerometers are used when shock pulses of extremely short durations occur in a test environment that would otherwise induce resonance in the sensor.

<sup>151</sup> The windshield is no longer included within the test area prescribed by the GTR.

<sup>152</sup> Informal document no. GR/PS/96, Problem of undamped accelerometer in headform impact test. 7th meeting of the pedestrian safety informal working group, Paris, France, September 28, 2004.

<sup>153</sup> Informal document no. GR/PS/133, Miniature Damped Accelerometer Series, 8th meeting of the pedestrian safety informal working group, Brussels, July 11, 2005.

<sup>154</sup> Also, pedestrian headforms, when used on the hood do not engage in metal-to-metal contact, nor do the hollowed aluminum hemispheres incur internal mechanical fractures.

potential testing of the windshield, cowl, and A-pillar. When testing such areas, the uncovered rear portion of the headform may come into contact with a vehicle structure such that an undamped accelerometer may produce a spurious signal and invalidate a test, similar to what was observed in J-NCAP testing. We request comment on the proposed use of damped accelerometers and whether it would be more appropriate to use an undamped accelerometer in proposed FMVSS No. 228, as is used in part 572 ATD heads.

This NPRM also proposes to specify the performance of the accelerometers in accordance with SAE J211/1\_202208 (2022), "Instrumentation for Impact Test Part 1—Electronic Instrumentation," in lieu of what GTR 9 references, which is ISO 6487 (2002), "Measurement Techniques in Impact Tests." SAE J211 and ISO 6487 are essentially equivalent. SAE J211 is the most current of the two, and FMVSSs have historically referenced SAE J211, not the ISO standard. For those reasons, we propose to reference the current version of SAE J211 in proposed FMVSS No. 228.<sup>155</sup>

## 5. Technical Assessment

### a. Hood Impact Tests

In our test program assessing the performance of the Cellbond and FTSS headforms on the 2010 Kia Forte, the 2010 Buick LaCrosse, and the 2010 Acura MDX (results above), we also used different types of accelerometers to assess the effect of damped versus undamped models. We examined our headform test signals for any indication of resonant vibrations and examined any differences in responses depending on whether damped or undamped accelerometers were used.<sup>156</sup>

At each of the six test points (three on the Buick, three on the Kia), one test was run with undamped units (in an FTSS headform) and two were run with damped units (one each for the FTSS and Cellbond headforms). The highest HIC score was recorded with the undamped (FTSS) unit for five of the six test points, with a percent difference ranging from 3 percent to 19 percent higher. For the other test point, all three HIC scores were nearly the same (less than 3 percent difference).

We also checked the test signals (figure IX.1) in all tests with undamped accelerometers and did not observe any

<sup>155</sup> This NPRM proposes to amend 49 CFR 571.5 to add SAE J211 (2022) to the list of material incorporated by reference in the Federal motor vehicle safety standards.

<sup>156</sup> In our examination of hood impact tests, we considered tests run only on the Buick and Kia because we observed variability in the way the hood of the Acura MDX deformed.

spurious signals to indicate that resonance frequencies had been reached. The undamped Endevco units that we used (model 7264C) had a resonant frequency rated at >26,000 Hz, which is extremely high relative to the

impulses typical of headform-to-hood impacts. We note that the natural frequency of the headform itself is much lower, specified as >5,000 Hz in the GTR. Thus, the root cause of resonance observed by J-NCAP might have been

ringing of the headform at a relatively low frequency, rather than excitation of the accelerometer at its rated (higher) frequency.

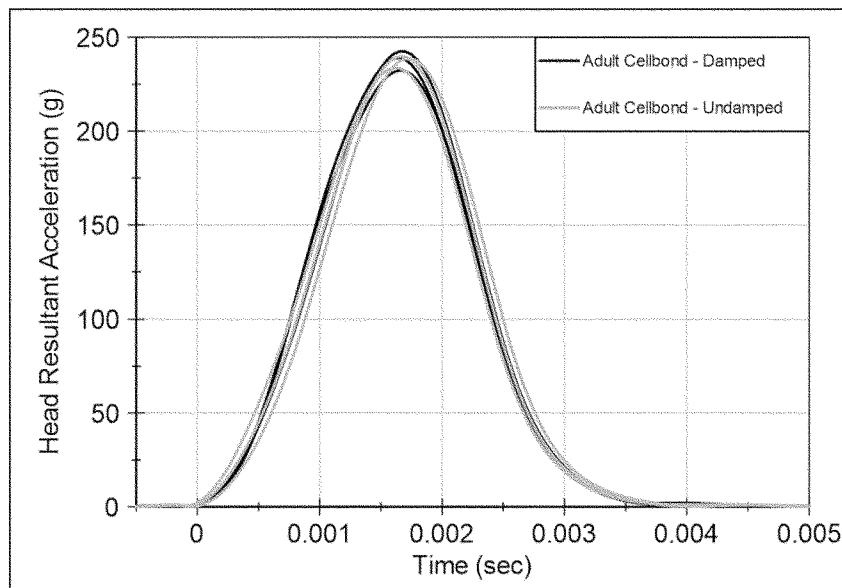

**Figure IX.1. Resultant acceleration results from Cellbond adult headform qualification tests with damped (red) and undamped (blue) accelerometers.**

#### b. Qualification Tests

We examined our qualification head drop signals for differences in responses depending on whether damped or undamped accelerometers were used. (This comparison was carried out for the Cellbond units only). We did not observe any consistent difference between accelerometer types. The magnitude in the peak acceleration was about the same for both. Also, we did not observe any perceptible phase shift.

### X. Other Issues

#### A. Active Hoods

An active hood uses actuators and lever arms to automatically lift the hood when a sensor detects that a pedestrian has been struck by the front-end of the vehicle. The system acts to pre-position the hood before the secondary (head) impact takes place with an oncoming pedestrian. In doing so, space is created between the hood and rigid components in the engine bay, thus reducing the risk of injury to the pedestrian. Compared to non-deploying hoods, active hoods offer the potential to greatly increase the free penetration space underneath the hood. They may be especially advantageous because they create extra space in the cowl area where pedestrian head strikes

to the hood are most apt to take place. NHTSA testing indicates that, historically, the rear of the hood near the cowl has included stiff structures, giving HIC values close to or above 1700, especially in areas near the hinges at the rear corners of the hood and around the wiper mounts. For vehicles with non-deploying hoods, the cowl usually lies rearward of the HIC Unlimited Margin of the Rear Reference Line. A HIC1700 relaxation area is typically allocated to the Adult Headform Test Area adjacent to the margin.

FMVSS No. 228 would include provisions in the compliance test procedure that provides for deployment of active hoods.<sup>157</sup> Consistent with GTR 9, this NPRM's regulatory text specifies

<sup>157</sup> GTR 9 does not directly address active hoods except to note that active hoods and other active safety devices "must not create a higher risk of injuries for the pedestrians." (United Nations (18 November 2004). *Global technical regulation No. 9: Pedestrian Safety* [Addendum to GTR] Geneva, Switzerland. Page 28, section A.8.b.122, and that "[a]ll devices designed to protect vulnerable road users when impacted by the vehicle shall be correctly activated before and/or be active during the relevant test. It shall be the responsibility of the manufacturer to show that any devices will act as intended in a pedestrian impact." *Id.*, page 50, section B.6.2.2.

that NHTSA will deploy an active hood in accordance with manufacturer instructions prior to launching the headform, including the irrevocable selection of the minimum and maximum period of time between device deployment and the impact of the headform to assure full deployment at impact. The proposed regulatory text does not set the conditions under which the active hood must activate, the timing of their activation and deployment, or provide performance criteria testing that the sensor works as intended. However, we have included a provision in the standard that would require manufacturers to, upon request and under the authority provided in 49 U.S.C. 30166 (NHTSA's enforcement authority), provide information to NHTSA explaining the basic operational characteristics of their active hood sensor system.<sup>158</sup>

Under FMVSS No. 228, the point of first contact between the headform and the hood would be determined while the hood is fully deployed. However,

<sup>158</sup> This provision is similar to that in FMVSS No. 226, "Ejection mitigation," regarding the sensor system and pertinent inputs to the algorithm used to determine when a side curtain will deploy in a real world rollover.

consistent with the GTR, the standard's test procedure would specify that the borders and test areas are marked off when the hood is in its normal, undeployed position as with a conventional hood. This is for practical reasons. Obviously, the agency is not able to mark off the hood when the hood is in a dynamic, moving state. We understand that the hood could be fixed in some deployed position. However, the current mark off method may not lend itself to the deployed surface and the transitions between the deployed hood and the fixed hood/fender areas without appropriated modification. Finally, the agency has not yet researched the implications of marking off a hood fixed in a deployed position.

NHTSA believes there are very few recent vehicles in the U.S. vehicle fleet with active hood designs. Therefore, data on their performance are limited. According to a 2014 survey of European sales data, only about 8% of new light vehicles sold in Europe had active hoods. North American variants of those models make up about 7% of light vehicle sales in the U.S.<sup>159</sup>

In general, vehicles with active hoods performed better than vehicles without active hoods in Euro NCAP tests. To date, NHTSA's research program has tested four vehicles equipped with active hood systems. Two of these vehicles (2014 Cadillac ATS, 2017 Audi A4) were U.S. variants retrofitted with European active hood components.<sup>160</sup> The reduction in HIC observed with the hood fully deployed was much greater for the Cadillac than for the Audi. However, NHTSA believes this difference reflected the vehicles' baseline performance when the hood is undeployed. More recently, NHTSA identified two U.S. market vehicles (2018 Buick Regal, 2021 Volkswagen Arteon) that have active hood systems. The HIC reduction observed in testing those vehicles with the hood fully deployed versus not deployed varied widely by vehicle and impact location.<sup>161</sup> At impact points already with low HIC without hood deployment, HIC reduction was minimal when an active hood was employed, while at stiffer impact points, hood deployment did improve

performance substantially in many instances.

Based on these test results, the safety benefit relative to the cost of implementing an active hood system may not be significant for some vehicles. However, there is still reason to believe that these types of systems may become more common in the U.S. market because it may be a viable design solution for some vehicles to meet the proposed pedestrian protection requirements. Therefore, NHTSA is considering developing a set of compliance test requirements to assure the proper deployment and function of active hoods. For example, we would like to consider the appropriateness of requirements for the lift mechanisms to assure that they do not collapse inappropriately under the full body weight of a pedestrian. We seek comment and data on the real-world performance and proper function of active hood systems observed in the E.U. and elsewhere. We request information to shed light on the reliability of the systems, including information on the rate of false-positive deployments. We are interested in learning more about the consequences to pedestrians if a collision occurs below the hood activation threshold. Would a pedestrian be placed in undue risk if the undeployed hood is overly stiff? Should there be HIC limits in headform impact tests on an undeployed hood to ensure HIC values are not too high (e.g., HIC values must be less than 1350)<sup>162</sup> when a test is conducted at a designated deployment threshold speed?

#### **XI. Effect on Other Standards**

NHTSA has examined the potential effect of this NPRM on other Federal motor vehicle safety standards and programs. As discussed below, the agency has determined that FMVSS No. 228 would not affect the ability of a vehicle to meet all other FMVSS applying to the vehicle. We request comment on our conclusions. Vehicles in the U.S. already have hoods that meet GTR 9, which indicates the compatibility of the GTR (and proposed FMVSS No. 228) with applicable FMVSSs. Further, GTR 9 has been implemented by Contracting Parties worldwide that have standards that are similar to many of those discussed below, which also show how pedestrian protective hoods meeting FMVSS No. 228 could be integrated into vehicle designs.

#### **Safety Standards**

FMVSS No. 104, Windshield wiping and washing systems, specifies requirements for windshield wiping and washing systems. FMVSS No. 228 would not affect the performance of the windshield wiping and washing systems, as the "hood area" subject to FMVSS No. 228 would preclude the area in which the systems are located.<sup>163</sup> If manufacturers would like to opt for designs where windshield wiper arms are hidden or made softer or deformable to better protect pedestrians, FMVSS No. 228 would not preclude such designs.

FMVSS No. 108, "Lamps, reflective devices and associated equipment," would not be affected by this proposed standard as the relevant equipment covered by Standard No. 108 would generally be outside of the hood area. Yet, if pop-up style headlights are in the hood area and are subject to headform testing, FMVSS No. 228 would require the vehicle to meet the tests when the lights are both deployed and in their stowed position. This is to optimize pedestrian protection in the real world, as an impact could occur when the movable lights are deployed and when they are stowed.

FMVSS No. 208, "Occupant crash protection," is intended to reduce the number of deaths of vehicle occupants, and the severity of injuries, by specifying vehicle crashworthiness requirements in terms of forces and accelerations measured on anthropomorphic dummies in frontal crashes, and by specifying equipment requirements for active and passive restraint systems. FMVSS No. 228 would not interfere with a manufacturer's ability to meet FMVSS No. 208, because the vehicle structures related to occupant protection in general and frontal crashes in particular, should be substantially unaffected by any redesign needed for pedestrian head protection.

FMVSS No. 113, "Hood latch system," requires that a front opening hood must be provided with a second latch position on the hood latch system. FMVSS No. 228 would not interfere with a vehicle's compliance with FMVSS No. 113 because vehicles are already manufactured to meet FMVSS No. 113 and the requirements of GTR 9 (and by implication, the proposed requirements of FMVSS No. 228).

FMVSS No. 401, "Interior trunk release," requires a trunk release

<sup>159</sup> Ames E., Martin P. "Pop-up Hood Pedestrian Protection," 24th Enhanced Safety of Vehicles, paper 15-0111 (2015).

<sup>160</sup> Suntay B., Stammen J. "Assessment of Hood Designs for Pedestrian Head Protection: Active Hood Systems," DOT HS 812 762 (2020).

<sup>161</sup> Suntay B., et al. "Vehicle Assessment using Integrated Crash Avoidance and Crashworthiness Pedestrian Safety Test Procedures" DOT HS 813 521.

<sup>162</sup> A HIC1350 limit is used in Euro NCAP in tests of this condition. We request comments on the merits of the HIC1350 threshold.

<sup>163</sup> NHTSA has requested comment in this NPRM on extending the testable area to the windshield. The NCAP RFC and Euro NCAP procedures test the windshield and the wiper and washing system area.

mechanism to enable a person trapped inside the trunk compartment of a passenger car to escape from the compartment. If the trunk is located in the front of the vehicle, the trunk lid would be subject to FMVSS No. 228. The agency believes that there is no conflict between providing a trunk (which is the hood, when located in front) release and FMVSS No. 228. The release mechanism would be similar to existing hood releases, except it would have a control inside the trunk.

FMVSS No. 219, "Windshield zone intrusion," provides that a vehicle's hood must not enter a defined zone in front of the vehicle's windshield during a frontal barrier crash test at 48 km/h (30 mph). The purpose of the standard is to reduce injuries and fatalities that result from occupant contact with vehicle components, such as the hood, that are displaced into the occupant compartment through the windshield or into the zone immediately forward of the windshield aperture during a frontal crash. NHTSA concludes that FMVSS No. 228 would not interfere with a vehicle's compliance with FMVSS No. 219, as vehicles are already manufactured that meet FMVSS No. 219 and the specifications of proposed FMVSS No. 228.

FMVSS No. 127 Pedestrian Automatic Emergency Braking (PAEB)

NHTSA plans for proposed FMVSS No. 228 to work with FMVSS No. 127 which includes a requirement for pedestrian automatic emergency braking (PAEB). PAEB safety systems are designed to stop the vehicle automatically before striking a pedestrian up to a certain speed or reduce the speed at which an impact occurs if the vehicle's initial speed is too high to avoid impact. More specifically, the target population for proposed FMVSS No. 228 was adjusted downward by anticipating the potential benefits of FMVSS No. 127. We also note that it is possible that there may be additional fatalities and non-fatal injuries that would fall into the target population potentially addressed by FMVSS No. 127 in cases that PAEB results in crash mitigation rather than avoidance. That is, for many impacts that cannot be avoided due to the closing speed of the vehicle, PAEB will lower the vehicle's speed so that more impacts will be at speeds of 40 km/h (25 mph) or less, which are pedestrian impacts that this proposed FMVSS No. 228 pedestrian head protection standard addresses. For these impacts FMVSS No. 228 would ensure the striking vehicles have features that protect against serious to fatal head injury in

these impacts. Due to data limitations, however, we are unable to estimate the number of additional fatalities and non-fatal injuries that may be potentially addressed by proposed FMVSS No. 228 following the adoption of FMVSS No. 127.

49 CFR Part 581, "Bumper Standard"

49 CFR part 581, issued under the Cost Savings Act,<sup>164</sup> applies to passenger cars. It specifies a set of vehicle bumper tests designed to reduce physical damage to the front and rear ends of a passenger motor vehicle from low speed (2.5 mph) collisions. NHTSA does not believe there is an incompatibility between the bumper standard and this NPRM. The proposed rule would not have a direct effect on the bumper area of vehicles.

Fuel Economy Standards

As explained below in the Benefits and Costs section of this notice, the costs associated with this proposal are assumed to be based on increased weight and its effect on fuel economy. See table XIII.2 for a breakdown of the estimated costs.

New Car Assessment Program

FMVSS No. 228, if adopted, would lay the regulatory foundation for NHTSA's adopting a crashworthiness pedestrian protection component into NHTSA's New Car Assessment Program (NCAP), as laid out in the May 26, 2023 NCAP RFC, *supra*. NCAP would build on proposed FMVSS No. 228 and incorporate enhanced crashworthiness tests into the consumer information program. The NCAP RFC proposes adding the majority of Euro NCAP's injury assessment scheme for head and leg test devices and the method in which scores for each impact point are calculated. These Euro NCAP tests correspond closely to those in GTR 9.

There are important differences, however, between FMVSS No. 228 and the NCAP RFC. While both mark off the Hood Top in a similar way and the impactors used for testing are the same, the final test areas differ, as do the outcomes of the tests (FMVSS No. 228 would have pass/fail criteria while NCAP would determine specific scores at each test point). The NCAP RFC test area is larger than the FMVSS No. 228 test area due to the HIC Unlimited Area on the sides of the Hood using a 50 mm offset (NCAP RFC) rather than the 82.5 mm Offset Line (FMVSS No. 228). In

<sup>164</sup> The Motor Vehicle Information and Cost Savings Act, 49 U.S.C. 325, provided for promulgation of bumper standards to reduce the economic loss resulting from damage to passenger motor vehicles involved in motor vehicle crashes.

section VI.C of this preamble, we requested comment on modifying the final rule offset to 50 mm.

Additionally, on the front boundary of the test area, the NCAP RFC does not utilize an 82.5 mm Offset Line and does not limit the testing to areas rearward of the LERL, if WAD1000 is forward of that line. Thus, test points may be on the bumper or grille area. For the FMVSS No. 228 procedure, there are no test points forward of the LERL, regardless of the WAD1000 location. Again, in section VI.C of this preamble we have requested comment on testing to WAD1000 regardless of its location and the most forward of WAD1000 or the 82.5 mm Offset line. Similarly, for the NCAP RFC there is no Offset Line of any size on the rear boundary. Additionally, the windshield is a valid impact location. In section VI.C of this preamble, we requested comment on extending the testing to WAD2100 and onto the windshield.

The NCAP RFC also differs from FMVSS No. 228 on how impact points are targeted. As explained, in section VII.C of this preamble, we explain how FMVSS No. 228 uses a first point of contact/3D method to target any point within the Child and Adult Headform Test Area that can be touched by the impactor. Thus, there are an infinite number of test locations. However, such a testing system does not lend itself to a scoring scheme. The NCAP RFC limits the number of valid test points by marking off a 100 mm by 100 mm grid within the test border. These grid points are targeted via the "Aiming Point," which is the intersection of the line of flight of the headform centerline with the hood surface. Due to the angle of the impact direction, the impact point on the hood will always be slightly forward of the Aiming Point. Nonetheless, the HIC score for the impact is assigned to the grid point that was aimed at (HIC15 < 650 = Green, 650 ≤ HIC15 < 1000 = Yellow, 1000 ≤ HIC15 < 1350 = Orange, 1350 ≤ HIC15 < 1700 = Brown, HIC15 ≥ 1700 = Red). This method has the benefit of being able to assign a HIC score to every grid point regardless of the contour of the hood, which is essential for a rating scheme. However, such a method is not necessary for FMVSS No. 228, which incorporates a pass/fail requirement for any point that can be contacted within the test area. In addition, the grid method is limited in its ability to test a specific location on the hood that may be particularly injurious to a pedestrian, which, again, is important for a minimum performance requirement.

For the NCAP RFC, the impactor used (Child versus Adult Headform) depends

on the WAD of the grid point. For grid points between WAD1000 and WAD1500, the Child Headform Impactor is used. For grid points between WAD1700 and WAD2100, the Adult Headform is used. The above is consistent with the FMVSS No. 228 procedure. However, unlike FMVSS No. 228, the NCAP RFC procedure has a provision where both the Child and Adult Headforms are used at grid locations between WAD1500 and WAD1700 if the RRL is within these WAD ranges. We noted this difference in section VI.C of this preamble, and request comment on modifying the final rule test procedure accordingly. As we stated earlier, we do not think that actual hoods will have an abrupt transition engineered into their design, and the FMVSS No. 228 procedure reduces the need to conduct unnecessary headform tests. Further, as the limited nature of the NCAP RFC grid points is more restrictive of testing than the proposed FMVSS No. 228 procedure, the grid approach lends itself more readily to the testing with both impactors in the transition zone.

Finally, the impact speed for the NCAP RFC is 40 km/h as opposed to 35 km/h in FMVSS No. 228. NHTSA sees no inherent conflict in this difference. We continue to believe the 35 km/h impact is well supported by field data as providing a regulatory minimum performance standard for pedestrian head impact. Using a higher impact speed in the NCAP RFC may mean that not all vehicles receive credit for NCAP pedestrian protection, thus giving consumers additional information with which to make their vehicle purchasing decision and incentivizing designs that go beyond the minimum provided to meet the FMVSS.

As the above discussion shows, there are important differences between the NCAP RFC and FMVSS No. 228. The fact that there will be a pedestrian crashworthiness component of NCAP does not mean there should not be a standard related to the same safety risk. For example, the introduction of the frontal and side crashworthiness portions of NCAP did not lead the agency to abandon standards in these areas. NCAP remains a consumer information program that provides important information for vehicle purchasing decisions, which encourages manufacturers to voluntarily make

changes to vehicles to attain positive NCAP test results and thereby improve safety. FMVSSs, on the other hand, are mandatory and specify a minimum level of safety that all vehicles sold must provide. The two programs are complementary and beneficial to safety.

## XII. Proposed Lead Time

We propose that FMVSS No. 228 would become effective the first September 1, two years after the date of publication of a final rule. For example, if a final rule were published in October of 2025, the effective date would be September 1, 2028. Most passenger cars, minivans, cross-over vehicles, and other vehicles under 3500 kg (7716 lb) GVWR sold in the U.S. share similar global designs as models currently sold in the E.U. Manufacturers probably would need considerably less time than two years to meet the requirements specified in the proposed rule due to their familiarity with similar requirements already established in the EU. However, we propose to allow manufacturers two years of lead time to assure that vehicles unique to the U.S. market—such as large SUVs and pickup trucks—are in full compliance with the standard.<sup>165</sup> In addition, two years may be needed even for the vehicles that have European variants.

This NPRM initiates the process of implementing GTR 9 into the FMVSS.<sup>166</sup> Throughout this NPRM, however, particularly in sections VI.C and XI, we have discussed our views on possibly adjusting the GTR's test protocols and some performance requirements to maximize safety benefits, address safety problems in the U.S., and develop a standard meeting Safety Act criteria. Comments are requested on whether, and the extent to which, such adjustments to implement or expand the requirements of the proposal would affect the lead time needed for manufacturers to implement the changes to their current vehicle designs that meet GTR 9.

From our observations of vehicle designs following the GTR in 2008, it seems that vehicle front-ends, including hoods, have evolved in design to meet European pedestrian protection requirements. The very latest vehicle models—those that have been designed with the GTR in mind from the platform level up—have contoured hoods, fenders, and headlamps that dovetail

closely with the borders and margins of the GTR. An example of this is seen in one of the vehicles we tested: the 2011 Hyundai Tucson. The Tucson has curved headlamps that blend into the fenders, and they are positioned just outside the Child Headform Test Area and right up to the HIC Unlimited Margin. Without the margin, about half of the headlamp would lie within the test area.

The GTR specifies that the rear border of the Child Headform Test Area is either the WAD1700 line or a line 82.5 mm forward of the Rear Reference Line, whichever is most forward. For the Tucson and the 2011 Buick Lacrosse, the two lines coincide (except for a very small area near the hinges). Thus, there is no Adult Headform Test Area for either of these vehicles. The design is such that the hood is exactly the size necessary to avoid having an Adult Headform Test Area. We believe this is unlikely to be a random occurrence. It appears that, for many years, vehicle manufacturers have considered the GTR provisions when designing their vehicles.

Notwithstanding how the current GTR border specifications seem to affect hood designs, the agency's test data, summarized in section VII.D, indicate that meeting the requirements discussed in this preamble are practicable and that testing beyond the GTR borders into the HIC Unlimited Area is also feasible. We request comments on the lead time needed to achieve these outcomes.

## XIII. Benefits and Costs

NHTSA has prepared a Preliminary Regulatory Impact Analysis (PRIA) that assesses the benefits, costs and other impacts of this NPRM.<sup>167</sup> Table XIII.1 provides a summary of the estimated annual incremental benefits in terms of injuries and fatalities mitigated by the proposed standard. The proposal is estimated to mitigate 67.4 fatalities. We note that overall injuries, and all injury levels except MAIS 3, are estimated to increase (represented by negative numbers in this table) because fatalities averted become higher level injuries and higher level injuries averted become lower-level injuries. Although the net total of non-fatal injuries from MAIS 1 to MAIS 5 increase under the proposed rule due to change in those fatalities and non-fatal injuries, overall there is a benefit at each MAIS level.

<sup>165</sup> Multistage manufacturers and alterers would be allowed an additional year of lead time, in accordance with 49 CFR 571.8(b).

<sup>166</sup> This NPRM uses different terminology than the GTR, but the specifications for determining test

borders and performance levels is consistent with GTR 9.

<sup>167</sup> The PRIA is available in the docket for this NPRM and may be obtained by downloading it or by contacting Docket Management at the address or

telephone number provided in the ADDRESSES section of this document.

TABLE XIII.1—SUMMARY OF ANNUAL INCREMENTAL BENEFITS

Injury severity	Benefits by vehicle type		Total benefits
	Passenger cars	LTVs	
MAIS 1 .....	-23.3	-47.2	-70.5
MAIS 2 .....	-3.7	1.2	-2.5
MAIS 3 .....	7.0	16.8	23.9
MAIS 4 .....	-0.7	-0.3	-1.1
MAIS 5 .....	-2.5	-2.6	-5.1
Fatalities .....	27.8	39.7	67.4

Note: Values may not sum due to rounding. Negative values represent an increase in the number of injuries at that specific severity.

Table XIII.2 provides the estimated annual cost of the proposal, broken down by passenger car and LTV. Many manufacturers of vehicles that would be subject to the proposed rule also manufacture vehicles in the European Union (EU) market. Potentially, some of these vehicles under production could be designed to a regulatory body's application of GTR 9 that may differ from a NHTSA rule implementing GTR 9 in the United States (see previous discussion of Amendment 3 in section VIII.B). Therefore, for such vehicles, there could be a potential one-time cost associated with redesigning vehicle hoods to comply with the requirements

adopted by NHTSA. The PRIA made use of a teardown study conducted by the agency to compare the same or similar models of vehicles with and without the countermeasures that would be used to meet the proposed rule. The assemblies had no perceived differences in design or assembly, but did indicate a slight difference in weight. Therefore, the potential one-time cost associated with redesigning vehicle hoods to meet the requirements specified in the proposed rule are expected to be negligible, especially when considered on a per-vehicle basis, across design cycles, and given the lead time specified in the proposed rule. This analysis estimates

the impact that the incremental weight associated with meeting the requirements specified in the proposed rule may have on fuel economy for passenger cars and LTVs, respectively.

As the costs associated with fuel economy are incurred over the course of a vehicle's lifespan, these costs are discounted. When discounted at 3% and 7%, the incremental cost associated with the impact to fuel economy is estimated to be in the range of \$2.86–\$3.50 for passenger cars. Similarly, LTVs have a per vehicle cost of \$3.29–\$4.08. The overall combined fleet cost range is estimated to be from \$48.9 million to \$60.4 million.

TABLE XIII.2—TOTAL ANNUAL COST

Category	Number of vehicles impacted	Per vehicle cost		Total fuel economy cost	
		Discounted at 3%	Discounted at 7%	Discounted at 3%	Discounted at 7%
Passenger Car .....	6,257,000	\$3.50	\$2.86	\$21,923,153	\$17,887,026
LTV .....	9,445,000	4.08	3.29	38,507,293	31,055,176
Total Annual Cost .....				60,430,447	48,942,202

Note: Values may not sum due to rounding.

Table XIII.3 provides a summary of the cost and benefits. To make a comparison across alternatives, the primary outcome of the regulatory action must be quantified on a single numerical index. Therefore, safety benefits, measured in fatalities and non-

fatal injuries mitigated, are translated to Equivalent Lives Saved (ELS) and monetized benefits. This table provides the cost, ELS, cost per ELS, monetized benefits (assuming benefits of \$11.9 million per ELS) and net benefits at the 3% and 7% discount rates. The overall

ELS ranges from 44.46 to 54.87. The cost per ELS is \$1.10 million. The overall monetized benefits range is \$529.74 million–\$653.76 million. After subtracting the cost at each discount rate, the overall net benefits range is \$480.79 million–\$593.3 million.

TABLE XIII.3—SUMMARY OF COSTS AND BENEFITS

[Millions]

Discount rate	Cost	Equivalent lives saved	Cost per equivalent live saved	Monetized benefits	Net benefits
3% .....	\$60.43	54.87	\$1.10	\$653.76	\$593.33
7% .....	48.94	44.46	1.10	529.74	480.79

**XIV. Considered Alternatives**

In several parts of this preamble, NHTSA explained how the agency is considering alternatives to the GTR-

based test procedure reflected in this NPRM's regulatory text. The agency requested comments on the alternatives that NHTSA would consider when developing the final rule.

- In section VI.C, several options for expanding the testable area were presented along with associated rationale. This also included



consideration of including the windshield as an additional testing area.

- In section VIII.B, GTR 9 Amendment 3 is discussed. Amendment 3 would, among other things, reduce the amount of HIC1000 test area compared to proposed FMVSS No. 228. In that section of the preamble, we provide the costs and benefits of a regulatory approach under Amendment 3. The details of this assessment can be found in the PRIA for this NPRM as Alternative 1.

- We now discuss a potential modification to the test procedure that would require the entire Hood Top to be tested. Under this version of the test procedure, the HIC Unlimited Area would no longer exist. Any point within the boundary of the Hood Top, as described in section VI.A, would be a valid impact point. The agency sees this as consistent with the notion that the HIC Unlimited areas were added due to practicability concerns, not based on the concept that a pedestrian’s head would not strike these parts of the Hood Top. Therefore, a procedure including these areas would provide an outcome more aligned with optimizing the safety benefits of this rulemaking. The PRIA discusses this approach as Alternative 3.

We believe reduction of the area of the hood that can be tested by subtracting areas at the perimeter of the Hood Top was based on the premise that it was simply not practicable to design hoods with perimeters that could

meet HIC1000 or HIC1700 limits. The agency test data summarized in section VII.D, however, indicates that it is feasible for U.S. vehicles to achieve the HIC requirements in the “HIC Unlimited Area.” Further, in order to achieve a significant safety benefit to pedestrians, the areas designated as the HIC Unlimited Area using the procedure in GTR 9 could, instead, be required to meet either a HIC 1000 or 1700 limit, depending on the manufacturer’s assignment of those respective areas on the vehicle.

Under a procedure where the entire Hood Top is tested, the HIC1000 Area could be required to cover at least two-thirds of the Hood Top and the HIC1700 Area could be required to cover the remainder. Additionally, it is our expectation, due to previous agency testing, that the 3D Method of impact point targeting would remain appropriate even at the edges of the Hood Top.

Under a test scheme that includes the entire Hood Top as the testable area, an issue discussed earlier in this preamble would remain for large vehicles whose LERL is rearward of WAD1000. For such vehicles, if the test area were limited only to the Hood Top, areas on the front of the vehicle that could be contacted by a child’s head would not be regulated. We note that this is also the case with the current proposed standard, as mentioned above in section VI.C.1.a. Comments are requested on the merits

of including a procedure for testing the grille area on such vehicles, assuming FMVSS No. 228 were to include the entire Hood Top as the testable area.

Table XIV.1 shows a comparison of the estimated benefits in terms of ELS and monetized benefits for an FMVSS No. 228 that reflects the wording of GTR 9 (presented in the NPRM’s regulatory text) and a requirement that would test the entire Hood Top. Additional details on the benefits and cost of the proposal are presented in section XIII. Under a requirement to test the entire Hood Top, both ELS and monetized benefits would be approximately 159% of that under the proposed rule (*i.e.*, the NPRM’s regulatory text).

NHTSA performed a break-even analysis for this alternative. This break-even analysis considers the cost at which this regulatory alternative would be net cost-effective and net beneficial. NHTSA estimated that break-even is at \$50.48–\$62.28 per vehicle cost, discounted at 7% and 3%. NHTSA requests information on the potential costs of this alternative.

Although this alternative is estimated to be substantially more beneficial than the rule presented in the NPRM’s regulatory text, in addition to a lack of information about cost, the agency believes there are unknowns related to the practicability of testing the entire Hood Top. The agency requests comment on the alternative of requiring testing of the entire Hood Top.

TABLE XIV.1—EQUIVALENT LIVES SAVED AND MONETIZED BENEFITS  
[Millions]

Regulatory option	Cost		Equivalent lives saved		Cost per equivalent life saved		Monetized benefits		Net benefits	
	3%	7%	3%	7%	3%	7%	3%	7%	3%	7%
#1: Requirements are the same as the E.U. interpretation of GTR 9 regarding test area (GTR 9 Amendment 3) .....	\$60.43	\$48.94	32.28	26.20	\$1.87	\$1.87	\$384.51	\$312.09	\$324.08	\$263.15
#2: Proposed Rule (as presented in the NPRM’s regulatory text) .....	60.43	48.94	54.87	44.46	1.10	1.10	653.76	529.74	593.33	480.79
#3: Requirements apply to the entire Hood Top (No HIC Unlimited Area) .....	.....	.....	87.13	70.61	.....	.....	1,038.3	841.51	.....	.....

**XV. Rulemaking Analyses and Notices**

*Executive Order (E.O.) 12866 (Regulatory Planning and Review), E.O. 13563, E.O. 14094, and DOT Rulemaking Procedures*

NHTSA has considered the impact of this rulemaking action under E.O. 12866, E.O. 13563, E.O. 14094, and the Department of Transportation’s regulatory procedures. This rulemaking is “significant” under E.O. 12866, “Regulatory Planning and Review,” and has been reviewed by the Office of Management and Budget. This NPRM

proposes to implement the provisions of GTR 9 into NHTSA’s regulations as a Federal Motor Vehicle Safety Standard, with possible adjustments to address safety issues and a regulatory framework that are unique to the U.S. The costs, benefits, and other economic impacts of this NPRM have been discussed in sections above and are analyzed in detail in the PRIA.

*Rulemaking Summary, 5 U.S.C. 553(b)(4)*

As required by 5 U.S.C. 553(b)(4), a summary of this rule can be found in

the Abstract section of the Department’s Unified Agenda entry for this rulemaking at <https://www.reginfo.gov/public/do/eAgendaViewRule?pubId=202304&RIN=2127-AK98>.

*Regulatory Flexibility Act*

Pursuant to the Regulatory Flexibility Act (5 U.S.C. 601 *et seq.*, as amended by the Small Business Regulatory Enforcement Fairness Act (SBREFA) of 1996) whenever an agency is required to publish a notice of proposed rulemaking or final rule, it must prepare and make available for public comment a

regulatory flexibility analysis that describes the effect of the rule on small entities (*i.e.*, small businesses, small organizations, and small governmental jurisdictions), unless the head of an agency certifies the rule will not have a significant economic impact on a substantial number of small entities. Agencies must also provide a statement of the factual basis for this certification. (5 U.S.C. 605(b))

I certify that this proposed rule would not have a significant economic impact on a substantial number of small entities. Although NHTSA is not required to issue an initial RFA, NHTSA sets forth the initial RFA below to provide the factual basis for the certification, and as a means of seeking comment on the certification and the economic impact of the proposed rule.

An initial RFA must contain (5 U.S.C. 603):

1. A description of the reasons why action by the agency is being considered;
2. A succinct statement of the objectives of, and legal basis for a proposed or final rule;
3. A description of and, where feasible, an estimate of the number of small entities to which the proposed or final rule will apply;
4. A description of the projected reporting, record keeping and other compliance requirements of a proposed or final rule including an estimate of the classes of small entities which will be subject to the requirement and the type of professional skills necessary for preparation of the report or record;
5. An identification, to the extent practicable, of all relevant Federal rules

which may duplicate, overlap, or conflict with the proposed or final rule;

6. A description of any significant alternatives to the proposed or final rule which accomplish the stated objectives of applicable status and which minimize any significant economic impact of the rule on small entities.

An RFA is not required if the head of the agency certifies that the proposed rule will not have a significant impact on a substantial number of small entities. The head of NHTSA has made such a certification. The factual basis for the certification (5 U.S.C. 605(b)) is set forth below. Although NHTSA is not required to issue an initial RFA, we discuss below many of the issues that an initial RFA would address.

1. A Description of the Reasons Why Action by the Agency Is Being Considered

NHTSA is considering this action to improve the safety of pedestrians. In particular, this action aims to address the injury severity in regard to head injuries incurred to pedestrians as the result of being struck by a light vehicle. By setting the HIC requirement, this action ensures that passenger vehicles are designed to mitigate the risk of serious to fatal child and adult head injury in pedestrian crashes. NHTSA is also initiating this rulemaking as part of the agency's obligations under the 1998 Agreement. See section IV of this preamble.

2. A Succinct Statement of the Objectives of, and Legal Basis for the Rulemaking

NHTSA is proposing these changes under the authority of 49 U.S.C. 322,

30111, 30115, 30117, and 30666, as well as a delegation of authority at 49 CFR 1.95. The agency is authorized to issue Federal motor vehicle safety standards that meet the need for motor vehicle safety.

3. A Description of and, Where Feasible, an Estimate of the Number of Small Entities to Which the Final Rule Will Apply

The proposed rule would affect motor vehicle manufacturers and second-stage or final stage manufacturers. We conducted an analysis to identify if there are any such firms that exist that are small businesses. Business entities are defined as small businesses using the North American Industry Classification System (NAICS) code. One of the criteria for determining size, as stated in 13 CFR 121.201, is the number of employees in the firm. For establishments primarily engaged in manufacturing or assembling automobiles, light- and heavy-duty trucks, buses, motor homes, and new tires the firm must have fewer than 1,500 employees to be classified as a small business, and motor vehicle body manufacturing which must have fewer than 1,000 employees.<sup>168</sup> For alterers and final-stage manufacturers, the firm must have fewer than 500 employees to be classified as a small business.<sup>169</sup>

Currently, there are at least 12 small light vehicle manufacturers in the United States.<sup>170</sup> Table XV.1 provides information about the 12 small volume domestic manufacturers in MY 2020. All are small manufacturers, having fewer than 1,500 employees.

TABLE XV.1—SMALL VOLUME VEHICLE MANUFACTURERS  
[MY 2020]<sup>171</sup>

Manufacturer	Type of vehicles	Number of employees (appx.)	MSRP for vehicles (appx.)
Anteros Coachworks .....	Specialty Sports Cars .....	2	\$110,000.
Callaway Cars .....	Specialty Sports Cars .....	50	~\$17,000 above base (GM) vehicle price.
Carroll Shelby International .....	Specialty Sports Cars .....	170	\$86,085–\$180,995+.
Equus Automotive .....	Specialty Sports Cars .....	25	\$250,000+.
Falcon Motorsports .....	Specialty Sports Cars .....	2	\$300,000–\$400,000.
Faraday Future .....	Electric .....	350	\$225,000.
Fisker Inc .....	Electric .....	<200	\$37,499+.
Karma Automotive .....	Electric .....	750	\$135,000.
Panoz .....	Specialty Sports Cars .....	<50	\$159,900+.
Rossion Automotive .....	Specialty Sports Cars .....	70	\$80,000.
Saleen Automotive .....	Specialty Sports Cars .....	170	\$48,000–\$100,000+.

<sup>168</sup> See NAICS codes 336110 (Automobile and Light Duty Motor Vehicle Manufacturing), 336120 (Heavy Duty Truck Manufacturing), and 336211 (Motor Vehicle Body Manufacturing) [https://www.sba.gov/sites/sbagov/files/2023-06/Table%20of%20Size%20Standards\\_Effective%20March%2017%2C%2023%20%28%29.pdf](https://www.sba.gov/sites/sbagov/files/2023-06/Table%20of%20Size%20Standards_Effective%20March%2017%2C%2023%20%28%29.pdf).

<sup>169</sup> See NAICS code 336211 (Motor Vehicle Body Manufacturing) [https://www.sba.gov/sites/sbagov/files/2023-06/Table%20of%20Size%20Standards\\_Effective%20March%2017%2C%2023%20%28%29.pdf](https://www.sba.gov/sites/sbagov/files/2023-06/Table%20of%20Size%20Standards_Effective%20March%2017%2C%2023%20%28%29.pdf).

<sup>170</sup> Classified in NAICS under Subsector 336—Transportation Equipment Manufacturing for

Automobile and Light Duty Motor Vehicle Manufacturing (336110) and Heavy Duty Truck Manufacturing (336120). Available at: <https://www.sba.gov/document/support-table-size-standards>.

<sup>171</sup> Provided to illustrate the current population of small vehicle manufacturers.

TABLE XV.1—SMALL VOLUME VEHICLE MANUFACTURERS—Continued  
[MY 2020]<sup>171</sup>

Manufacturer	Type of vehicles	Number of employees (appx.)	MSRP for vehicles (appx.)
SSC North America .....	Specialty Sports Cars .....	9	\$2,000,000.

4. A Description of the Projected Reporting, Recordkeeping and Other Compliance Requirements of the Proposed Rule, Including an Estimate of the Classes of Small Entities Which Will Be Subject to the Requirement and the Type of Professional Skills Necessary for Preparation of the Report or Record

The proposed rule does not create any new reporting or recordkeeping requirements, nor does it affect any existing reporting or recordkeeping requirements.

Manufacturers would have to self-certify the compliance of their vehicles with the new FMVSS No. 228. Manufacturers currently self-certify the compliance of their vehicles to a host of Federal motor vehicle safety standards, many of which are much more complex than the standard proposed by this NPRM. The burden and cost of certifying to proposed FMVSS No. 228 is relatively small. The performance test is done with an impactor without crash testing the vehicles, and multiple impacts can be performed on a single hood to assess conformance. The vehicle manufacturer is not required by the FMVSS to test every point on the hood; instead, it only must ensure that the hood will meet FMVSS No. 228 when tested by NHTSA in an agency compliance test. Thus, the small manufacturer, knowing its vehicle, can identify the part of the hood least likely to meet the standard and can focus its testing there. If that part of the hood can be made to meet the standard, the small manufacturer can determine through engineering analyses and other means that other parts of the hood can meet the standard as well. This is to say, a small entity is not directed by the standard to test in any way. Small entities can easily base their certification on simple headform testing, straightforward engineering analyses, modeling, a combination of these, or other such means to certify to the proposed standard.

Although a small entity is not required by NHTSA to test to self-certify compliance with proposed FMVSS No. 228, if they wish to perform the physical tests described in the proposed standard, they could readily contract with an outside testing laboratory to

conduct the headform impact tests in the proposal. (NHTSA itself has contracted with labs for such testing in the past.) The number of tests to be performed on a particular hood to certify compliance would be at the discretion of the manufacturer. Because of the manufacturer's in-depth knowledge of its vehicle design, the symmetry of hood design and predictability of results, and the depth of engineering judgment and knowledge in this area, however, NHTSA believes it is reasonable that the number of necessary test points could be reduced to the locations with the least compliance margin. To illustrate, NHTSA in the past has assessed hood performance based on a test series of 10 impacts, at a total cost of approximately \$8,000 for the 10 impacts. Because these impacts may involve more than a single hood, we would include an additional cost for hood parts, which results in an overall estimated testing cost of \$10,000 for certification testing. This overall cost can then be amortized over the entire number of vehicles produced matching the test design. Thus, the amortized cost would not constitute a significant percentage of the relative cost of the vehicle. Comments are requested on these estimates.

As with large manufacturers, small manufacturers would self-certify compliance to FMVSS No. 228 by the same certification label now required for all applicable Federal motor vehicle safety standards. The label is placed on the vehicle, usually in the door jamb on light vehicles. Adding FMVSS No. 228 certification to the label is expected to result in minimal impact on small entities.

NHTSA does not believe the small manufacturers listed in table XV.1 of this analysis are developing hood systems and/or related hardware for installation on the vehicles they manufacture. In today's motor vehicle market, small vehicle manufacturers, who are less able than large manufacturers to take advantage of economies of scale to lower production costs, typically produce specialized, expensive vehicles and could obtain the hoods from a supplier (a large entity). Regardless of whether small manufacturers turn to a supplier, the

vehicle manufacturer would be able to certify its vehicles to FMVSS No. 228 through the use of energy-absorbing structures and strategic layout of hard engine components vis-a-vis the hood surface; designing and manufacturing a compliant hood is relatively uncomplicated.

Furthermore, there are a significant number of final-stage manufacturers and alterers (several hundred) that could be impacted by the proposed rule. These manufacturers buy incomplete vehicles from the first-stage vehicle manufacturers or complete vehicles that they alter before first sale, respectively. Many of these vehicles are van conversions, but there are a variety of vehicles affected. These final-stage manufacturers would likely meet the standard by passing on the costs of compliance by the first-stage vehicle manufacturer to the consumer. Alterers would likely refrain from modifying the hood, which allows them to pass on the compliance costs by the original manufacturer of the vehicle to the consumer. Thus, while there are a substantial number of final stage manufacturers and alterers potentially impacted by the proposed rule, we do not believe the proposed rule will have a significant economic impact on the entities. Either a pass-through certification process will apply to these manufacturers, or they will do the work themselves to certify the vehicle.

NHTSA does not believe that the potential costs of any necessary hood design would have significant impacts on a substantial number of small entities. In considering potential costs associated with redesigning hoods, we first note that this potential one-time cost would be spread out on a per-vehicle basis, with costs shared across model years of a given generation. Furthermore, as the majority of the small entities identified also sell vehicles in the EU,<sup>172</sup> much of the burden and associated cost of redesigning hoods would already be

<sup>172</sup> At least seven of the 12 small entities identified also sold vehicles in the EU. For those who may not sell vehicles in the EU, the average vehicle sales prices was approximately \$587,000 and would likely require a special order for purchase.

incurred to meet the standards already in place in the EU.

NHTSA considers in this paragraph how such costs may impact these small entities. It is assumed that any incremental costs incurred to meet the requirements specified in the proposed rule would be passed on to consumers and, therefore, potentially impact demand. The vehicles produced by manufacturers listed in the table can roughly be grouped into three classes: (1) luxury/ultra-luxury vehicles; (2) alternative electric vehicles; and (3) modified vehicles from other manufacturers. Luxury/ultra-luxury vehicles are considered to be Veblen goods. Veblen goods are those in which demand increases as price increases. Therefore, any potential incremental costs would not have negative impacts on the demand for these particular vehicles. Additionally, as all three categories of the vehicles manufactured by these small entities are specialty vehicles, demand for these vehicles would be inelastic due to a lack of substitutes. That is, it is expected that consumers who seek out these specific vehicles would not be impacted by potential price changes as a result of manufacturers passing costs on to consumers.

#### 5. An Identification, to the Extent Practicable, of All Relevant Federal Rules Which May Duplicate, Overlap, or Conflict With The Proposed Rule

We know of no Federal rules which duplicate, overlap, or conflict with this proposed rule.

#### 6. Each RFA Shall Also Contain a Description of Any Significant Alternatives to the Proposed Rule Which Accomplish the Stated Objectives of Applicable Statutes and Which Minimize any Significant Economic Impact of the Proposal on Small Entities

In addition to the requirements included in this NPRM, NHTSA considered a less stringent regulatory alternative in which the requirements specified in the proposed rule would match the E.U. interpretation of GTR 9 and a more stringent alternative in which the requirements specified in the proposed rule would be applicable to the entire Hood Top, *i.e.*, the Test Area would encompass the entire Hood Top. When comparing the less stringent regulatory alternative to the proposed rule, NHTSA determined that the costs would be very similar, and due to data limitations, assumed the costs to be the same. The proposed rule, however, provides more benefits relative to the less stringent regulatory alternative.

While the more stringent regulatory alternative would offer greater overall benefits, we were unable to estimate the cost for the more stringent regulatory alternative due to data limitations. Overall, the less stringent regulatory alternative and proposed rule are only associated with fuel economy costs incurred over the life span of the vehicles impacted. Due to uncertainty about the feasibility and costs associated with the more stringent regulatory alternative, NHTSA was not able to assess the potential impacts of that regulatory alternative on small entities. While costs could increase with the more stringent regulatory alternative, it is not NHTSA's preferred alternative. If the agency decides the alternative should be further pursued, the agency will consider the impacts to small entities when determining whether to finalize the more stringent regulatory alternative.

We have identified no meaningful alternatives that both: (1) do not rely on the establishment of a HIC requirement; and (2) are expected to achieve improvements in pedestrian safety consistent with those expected under the proposed rule. However, in recognition of manufacturing differences between large manufacturers and these specific types of small manufacturers, NHTSA is proposing to provide final-stage manufacturers and alterers an additional year of lead time for manufacturer certifications of compliance.<sup>173</sup> NHTSA anticipates that hood components and designs meeting FMVSS No. 228 may be developed by vehicle designers and suppliers and integrated into the fleets of larger vehicle manufacturers first, before these small manufacturers. This NPRM recognizes this and proposes to provide final-stage manufacturers and alterers more lead time. As designers and suppliers may prioritize meeting the demands of larger manufacturers, this additional lead time will allow small manufacturers to work with designers and suppliers without any stoppage in production. Although, as discussed above, we do not project the proposed rule to have a significant economic impact on a substantial number of small entities, the additional lead time would provide flexibility to further minimize any impacts. The NPRM does not provide additional lead time for other small manufacturers such as listed in table XV.1 who manufacture complete vehicles because the latter have the engineering resources to certify compliance in the same time frame as large manufacturers. Such small

manufacturers perform or control much of the design and development of the vehicles they produce unlike typical final-stage manufacturers and alterers. With their engineering resources and control over the manufacturing processes, those small manufacturers have the ability to consider the proposed FMVSS No. 228 requirements and modify the hood as needed, like other manufacturers.

#### *National Environmental Policy Act*

NHTSA has analyzed this rulemaking for the purposes of the National Environmental Policy Act and determined that it will not have any significant impact on the quality of the human environment.

#### *Executive Order 13132 (Federalism)*

NHTSA has examined this proposed rule pursuant to Executive Order 13132 (64 FR 43255, August 10, 1999) and concluded that no additional consultation with States, local governments or their representatives is mandated beyond the rulemaking process. The agency has concluded that the rulemaking will not have sufficient federalism implications to warrant consultation with State and local officials or the preparation of a federalism summary impact statement. The proposed rule will not have "substantial direct effects on the States, on the relationship between the national government and the States, or on the distribution of power and responsibilities among the various levels of government."

NHTSA rules can preempt in two ways. First, the National Traffic and Motor Vehicle Safety Act contains an express preemption provision: When a motor vehicle safety standard is in effect under this chapter, a State or a political subdivision of a State may prescribe or continue in effect a standard applicable to the same aspect of performance of a motor vehicle or motor vehicle equipment only if the standard is identical to the standard prescribed under this chapter. 49 U.S.C. 30103(b)(1). It is this statutory command by Congress that preempts any non-identical State legislative and administrative law addressing the same aspect of performance.

The express preemption provision described above is subject to a savings clause under which "[c]ompliance with a motor vehicle safety standard prescribed under this chapter does not exempt a person from liability at common law." 49 U.S.C. 30103(e). Pursuant to this provision, State common law tort causes of action against motor vehicle manufacturers

<sup>173</sup>This approach accords with 49 CFR 571.8(b).

that might otherwise be preempted by the express preemption provision are generally preserved.

However, the Supreme Court has recognized the possibility, in some instances, of implied preemption of such State common law tort causes of action by virtue of NHTSA's rules, even if not expressly preempted. This second way that NHTSA rules can preempt is dependent upon there being an actual conflict between an FMVSS and the higher standard that would effectively be imposed on motor vehicle manufacturers if someone obtained a State common law tort judgment against the manufacturer, notwithstanding the manufacturer's compliance with the NHTSA standard. Because most NHTSA standards established by an FMVSS are minimum standards, a State common law tort cause of action that seeks to impose a higher standard on motor vehicle manufacturers will generally not be preempted. However, if and when such a conflict does exist—for example, when the standard at issue is both a minimum and a maximum standard—the State common law tort cause of action is impliedly preempted. See *Geier v. American Honda Motor Co.*, 529 U.S. 861 (2000).

Pursuant to Executive Orders 13132 and 12988, NHTSA has considered whether this rulemaking could or should preempt State common law causes of action. The agency's ability to announce its conclusion regarding the preemptive effect of one of its rules reduces the likelihood that preemption will be an issue in any subsequent tort litigation. To this end, the agency has examined the nature (*e.g.*, the language and structure of the regulatory text) and objectives of this proposed rule and finds that it, like many NHTSA rules, would prescribe only a minimum safety standard. As such, NHTSA does not intend this rulemaking to preempt state tort law that would effectively impose a higher standard on motor vehicle manufacturers than that established by the rule. Establishment of a higher standard by means of State tort law will not conflict with the minimum standard adopted here. Without any conflict, there could not be any implied preemption of a State common law tort cause of action.

#### *Civil Justice Reform*

Section 3(b) of Executive Order 12988, "Civil Justice Reform" (61 FR 4729, February 7, 1996) requires that, when promulgating a new regulation, Executive agencies make every reasonable effort to ensure that the regulation: (1) Clearly specifies any preemptive effect; (2) clearly specifies

any effect on existing Federal law or regulation; (3) provides a clear legal standard for affected conduct, while promoting simplification and burden reduction; (4) clearly specifies the retroactive effect, if any; (5) adequately defines key terms, either explicitly or by reference to other regulations or statutes that explicitly define those items; and (6) addresses other important issues affecting clarity and general draftsmanship of regulations under any guidelines issued by the Attorney General. This document is consistent with that requirement.

Pursuant to this Order, NHTSA notes as follows. The preemptive effect of this proposed rule is discussed above. NHTSA notes further that there is no requirement that individuals submit a petition for reconsideration or pursue other administrative proceeding before they may file suit in court.

#### *Paperwork Reduction Act (PRA)*

Under the PRA of 1995, a person is not required to respond to a collection of information by a Federal agency unless the collection displays a valid OMB control number. The agency has analyzed the proposed standard and determined that there are no reporting requirements that require an OMB control number. The proposed regulatory text would require that information must be made available under the agency enforcement authority provided in 49 U.S.C. 30166.

#### *National Technology Transfer and Advancement Act*

Section 12(d) of the National Technology Transfer and Advancement Act (NTTAA) requires NHTSA to evaluate and use existing voluntary consensus standards in its regulatory activities unless doing so would be inconsistent with applicable law (*e.g.*, the statutory provisions regarding NHTSA's vehicle safety authority) or otherwise impractical.

Voluntary consensus standards are technical standards developed or adopted by voluntary consensus standards bodies. Technical standards are defined by the NTTAA as "performance-based or design-specific technical specification and related management systems practices." They pertain to "products and processes, such as size, strength, or technical performance of a product, process or material." Examples of organizations generally regarded as voluntary consensus standards bodies include the American Society for Testing and Materials (ASTM), the Society of Automotive Engineers (SAE), and the American National Standards Institute

(ANSI). If NHTSA does not use available and potentially applicable voluntary consensus standards, we are required by the Act to provide Congress, through OMB, an explanation of the reasons for not using such standards.

This proposal to adopt GTR 9 is consistent with the goals of the NTTAA. This NPRM proposes to adopt a global consensus standard. The GTR was developed by a global regulatory body and is designed to increase global harmonization of differing vehicle standards. The GTR leverages the expertise of governments in developing a vehicle standard to reduce the risk of pedestrian head injury in impacts. NHTSA's consideration of GTR 9 accords with the principles of NTTAA as NHTSA's consideration of an established, proven regulation has reduced the need for NHTSA to expend significant agency resources on the same safety need addressed by GTR 9. This NPRM explains the reasons the FMVSS under consideration differs in some respects from GTR 9, and why NHTSA is considering additional changes to GTR 9 for the final rule. NHTSA will consider the comments to the NPRM and other information in drafting a final rule. If differences remain between the final rule and the GTR, the agency will explain in the final rule NHTSA's reasons for deciding such differences are warranted, consistent with the NTTAA.

#### *Unfunded Mandates Reform Act*

Section 202 of the Unfunded Mandates Reform Act of 1995 (UMRA), Public Law 104-4, requires Federal agencies to prepare a written assessment of the costs, benefits, and other effects of proposed or final rules that include a Federal mandate likely to result in the expenditure by State, local, or tribal governments, in the aggregate, or by the private sector, of more than \$100 million (adjusted for inflation with base year of 1995) in any one year. Adjusting this amount by the implicit gross domestic product price deflator for the year 2021 results in \$178 million (2021 index value of 270.97/1995 index value of 152.40 = 1.78<sup>174</sup>). This proposed rule would not result in a cost of \$178 million or more in any one year to either State, local, or tribal governments, in the aggregate, or the private sector. Thus, this proposed rule is not subject to the requirements of sections 202 of the UMRA.

<sup>174</sup> Consumer Price Index Data from 1913 to 2023 (usinflationcalculator.com)

### *Incorporation by Reference*

Under regulations issued by the Office of the Federal Register (1 CFR 51.5(a)), an agency must summarize in the preamble of a proposed or final rule the material it incorporates by reference and discuss the ways the material is reasonably available to interested parties or how the agency worked to make materials available to interested parties.

NHTSA proposes to incorporate by reference SAE Recommended Practice J211-1, "Instrumentation for Impact Test—Part 1—Electronic Instrumentation," revised August 2022 (SAE J211/1). Previous versions of this SAE standard are incorporated in 49 CFR 571.5(l)(2) through (5). The SAE J211/1 standard provides guidelines and recommendations for techniques of measurements used in impact tests to achieve uniformity in instrumentation practice and in reporting results. Signals from impact tests have to be filtered following the standard's guidelines to eliminate noise from sensor signals. Following J211/1 guidelines provides a basis for meaningful comparisons of test results from different sources. The SAE material is available for review at NHTSA and is available from SAE International.

### *Severability*

The issue of severability of FMVSSs is addressed in 49 CFR 571.9. It provides that if any FMVSS or its application to any person or circumstance is held invalid, the remainder of the part and the application of that standard to other persons or circumstances is unaffected. NHTSA seeks comment on the issue of severability.

### *Regulation Identifier Number*

The DOT assigns a regulation identifier number (RIN) to each regulatory action listed in the Unified Agenda of Federal Regulations. The Regulatory Information Service Center publishes the Unified Agenda in April and October of each year. You may use the RIN contained in the heading at the beginning of this document to find this action in the Unified Agenda.

### *Plain Language*

Executive Order 12866 requires each agency to write all rules in plain language. Application of the principles of plain language includes consideration of the following questions:

- Have we organized the material to suit the public's needs?
- Are the requirements in the rule clearly stated?
- Does the rule contain technical language or jargon that isn't clear?

- Would a different format (grouping and order of sections, use of headings, paragraphing) make the rule easier to understand?

- Would more (but shorter) sections be better?
- Could we improve clarity by adding tables, lists, or diagrams?
- What else could we do to make the rule easier to understand?

If you have any responses to these questions, please write to us with your views.

### **XVI. Public Participation**

#### *How long do I have to submit comments?*

Please see **DATES** section at the beginning of this document.

#### *How do I prepare and submit comments?*

- Your comments must be submitted in writing.
- To ensure that your comments are correctly filed in the Docket, please include the Docket Number shown at the beginning of this document in your comments.
- Your comments must not be more than 15 pages long. (49 CFR 553.21). We established this limit to encourage you to write your primary comments in a concise fashion. However, you may attach necessary additional documents to your comments. There is no limit on the length of the attachments.

- If you are submitting comments electronically as a PDF (Adobe) File, NHTSA asks that the documents be submitted using the Optical Character Recognition (OCR) process, thus allowing NHTSA to search and copy certain portions of your submissions. Comments may be submitted to the docket electronically by logging onto the Docket Management System website at <http://www.regulations.gov>. Follow the online instructions for submitting comments.

- Please note that pursuant to the Data Quality Act, in order for substantive data to be relied upon and used by the agency, it must meet the information quality standards set forth in the OMB and DOT Data Quality Act guidelines. Accordingly, we encourage you to consult the guidelines in preparing your comments. OMB's guidelines may be accessed at <https://www.govinfo.gov/content/pkg/FR-2002-02-22/pdf/R2-59.pdf>. DOT's guidelines may be accessed at <https://www.transportation.gov/dot-information-dissemination-quality-guidelines>.

### Tips for Preparing Your Comments

When submitting comments, please remember to:

- Identify the rulemaking by docket number and other identifying information (subject heading, **Federal Register** date, and page number).
- Explain why you agree or disagree, suggest alternatives, and substitute language for your requested changes.
- Describe any assumptions and provide any technical information and/or data that you used.
- If you estimate potential costs or burdens, explain how you arrived at your estimate in sufficient detail to allow for it to be reproduced.
- Provide specific examples to illustrate your concerns and suggest alternatives.
- Explain your views as clearly as possible, avoiding the use of profanity or personal threats.
- Make sure to submit your comments by the comment period deadline identified in the **DATES** section above.

#### *How can I be sure that my comments were received?*

If you wish Docket Management to notify you upon its receipt of your comments, enclose a self-addressed, stamped postcard in the envelope containing your comments. Upon receiving your comments, Docket Management will return the postcard by mail.

#### *How do I submit confidential business information?*

If you wish to submit any information under a claim of confidentiality, you should submit three copies of your complete submission, including the information you claim to be confidential business information, to the Chief Counsel, NHTSA, at the address given above under **FOR FURTHER INFORMATION CONTACT**. In addition, you should submit two copies, from which you have deleted the claimed confidential business information, to Docket Management at the address given above under **ADDRESSES**. When you send a comment containing information claimed to be confidential business information, you should include a cover letter setting forth the information specified in our confidential business information regulation. (49 CFR part 512). To facilitate social distancing during COVID-19, NHTSA is temporarily accepting confidential business information electronically. Please see <https://www.nhtsa.gov/coronavirus/submission-confidential-business-information> for details.

*Will the Agency consider late comments?*

We will consider all comments that Docket Management receives before the close of business on the comment closing date indicated above under **DATES**. To the extent possible, we will also consider comments that Docket Management receives after that date. If Docket Management receives a comment too late for us to consider in developing the final rule, we will consider that comment as an informal suggestion for future rulemaking action.

*How can I read the comments submitted by other people?*

You may read the comments received by Docket Management at the address given above under **ADDRESSES**. The hours of the Docket are indicated above in the same location. You may also see the comments on the internet. To read the comments on the internet, go to <https://www.regulations.gov>. Follow the online instructions for accessing the dockets.

Please note that, even after the comment closing date, we will continue to file relevant information in the Docket as it becomes available. Further, some people may submit late comments. Accordingly, we recommend that you periodically check the Docket for new material.

*Potential Equity or Climate Change Impacts*

The DOT recognizes that climate variability and change pose potential threats to U.S. transportation systems. In addition, ensuring equity and accessibility for every member of the traveling public is one of the Department's highest priorities. NHTSA requests comment on any potential climate change or equity impact of this proposed rule.

*Privacy Act*

In accordance with 5 U.S.C. 553(c), DOT solicits comments from the public to better inform its decision-making process. DOT posts these comments, without edit, including any personal information the commenter provides, to [www.regulations.gov](http://www.regulations.gov), as described in the system of records notice (DOT/ALL-14 FDMS), which can be reviewed at [www.transportation.gov/privacy](http://www.transportation.gov/privacy) and <https://www.transportation.gov/individuals/privacy/privacy-act-system-records-notices>. To facilitate comment tracking and response, the agency encourages commenters to provide their name, or the name of their organization; however, submission of names is completely optional. Whether or not

commenters identify themselves, all timely comments will be fully considered.

**List of Subjects in 49 CFR Part 571**

Imports, Motor vehicle safety, Reporting and recordkeeping requirements, Tires.

In consideration of the foregoing, NHTSA proposes to amend 49 CFR part 571 as set forth below.

**PART 571—FEDERAL MOTOR VEHICLE SAFETY STANDARDS**

■ 1. The authority citation for part 571 continues to read as follows:

**Authority:** 49 U.S.C. 322, 30111, 30115, 30117 and 30166; delegation of authority at 49 CFR 1.95.

■ 2. Section 571.5 paragraph (l) is amended by redesignating paragraphs (6) through (51) as paragraphs (7) through (52) and adding new paragraph (6) to read as follows:

**§ 571.5 Matter incorporated by reference.**

\* \* \* \* \*

(l) \* \* \* \* \*

(6) SAE Recommended Practice J211-1 AUG2022, "Instrumentation for Impact Test—Part 1—Electronic Instrumentation," revised August 2022, into § 571.228.

\* \* \* \* \*

■ 3. Section 571.228 is added to read as follows:

**§ 571.228 Standard No. 228; Pedestrian head protection.**

S1. *Scope.* This standard establishes performance requirements for vehicle hoods to protect pedestrians against head injury.

S2. *Purpose.* The purpose of this standard is to reduce the risk of injury to pedestrians in the event of a collision.

S3. *Application.* This standard applies to passenger cars and to multipurpose passenger vehicles, trucks, and buses with a GVWR of 4,536 kg or less, except for multipurpose passenger vehicles, trucks, and buses where the distance, measured longitudinally on a horizontal plane, between the transverse centerline of the front axle and the seating reference point of the driver's seat is less than 1000 mm. This standard also applies to any bidirectional vehicles within the subset of vehicles described in this paragraph.

S4. *Definitions.* (All references below are to this Standard No. 228, 49 CFR 571.228, unless otherwise specified.)

*Adult Headform Test Area* means the area specified in S6.5.4.

*Bidirectional vehicle* means a vehicle that is intended to operate at similar

speeds and with similar maneuverability in both directions of the vehicle longitudinal axis.

*Child Headform Test Area* means the area of the vehicle hood specified in S6.5.3.

*Combined Child and Adult Headform Test Area* means the areas of the Child Headform Test Area and Adult Headform Test Area together. If the Adult Headform Test Area does not exist, the Child Headform Test Area represents the Combined Child and Adult Headform Test Area.

*Corner reference point of the Child Headform Test Area* means the intersection of the Child Headform Test Area (6.5.3) front border (HIC Unlimited Margin of the Leading Edge Reference Line (S6.4.2) and the side border (HIC Unlimited Margin of the Side Reference Line (S6.4.3)). Where multiple intersections occur, the most outboard intersection is the corner reference point of the Child Headform Test Area and constitutes the endpoint of the Child Headform Test Area front border and side border.

*Corner reference point of the Hood Area* means the intersection of the Hood Area (6.5.2) front border (Leading Edge Reference Line (S6.3.2) or the WAD1000 line (S6.3.1)) and the side border (Side Reference Line (S6.3.3)). Where multiple intersections occur, the most outboard intersection defines the corner reference point of the Hood Area and constitutes the endpoint of the Hood Area front border and the side border.

*Corner reference point of the Hood Top* means the intersection of the Hood Top (6.5.1) front border (Leading Edge Reference Line (S6.3.2)) and the side border (Side Reference Line (S6.3.3)). Where multiple intersections occur, the most outboard intersection defines the corner reference point of the Hood Top and constitutes the endpoint of the Hood Top front border and the side border.

*Front* means the leading portion of the vehicle during typical operation, except for non-bidirectional vehicles that are operating in a reverse gear intended for vehicles maneuvering in small areas.

*Ground reference plane* means a horizontal plane that passes through the lowest points of contact for all tires of the vehicle.

*Headform* means a device specified in S8 and is the moving mass that strikes the vehicle.

*Head Injury Criterion (HIC)* means an injury severity score that is computed from accelerometer time histories using the following formula:

$$\text{HIC} = \left[ \frac{1}{t_2 - t_1} \int_{t_1}^{t_2} a \, dt \right]^{2.5} (t_2 - t_1)$$

Where:

*a* is the resultant acceleration measured in units of gravity “g” (1 g = 9.81 m/s<sup>2</sup>);  
*t*<sub>1</sub> and *t*<sub>2</sub> are the two time instants during the impact expressed in seconds, defining an interval between the beginning and the end of the recording period for which the value of HIC is a maximum (*t*<sub>2</sub> - *t*<sub>1</sub> ≤ 15 ms)

*HIC Unlimited Area* means the area that shares an outer boundary with the Hood Top and whose inner boundary is the HIC Unlimited Margin. (See figure 7.)

*HIC Unlimited Margin* means the inner boundary of the HIC Unlimited Area. It is the same as the outer boundary of the Combined Child and Adult Headform Test Areas. (See figure 7.)

*HIC1000 Area* means the area within the Child Headform Test Area and Adult Headform Test Area with a minimum area as specified in S5.2 and where the HIC value must not exceed 1,000, as specified in S5.1(a).

*HIC1700 Area* means the area with borders as specified in S5.5 and where the HIC value must not exceed 1,700, as specified in S5.1(b).

*Hood Area* means the area enclosed by the borders specified in S6.5.2 that provides the basis for the amount of area in the Child Headform Test Area and the Adult Headform Test Area, which must be HIC1000 Area, as specified by S5.2.

*Hood Top* means the area enclosed by the borders specified in S6.5.1 and consisting of the HIC Unlimited Area, Child Headform Test Area and Adult Headform Test Area.

*Impact point(s)* means the point(s) on the vehicle where the initial contact with the headform occurs (point A in figure 1, provided for illustration purposes). It is permissible to have multiple simultaneous points of initial contact resulting from a headform launch. HIC value requirements for multiple simultaneous points of initial contact are specified in S5.3.

*Non-contactable surfaces* means areas within the Hood Top that cannot be contacted by the headform due to the geometry of the hood, such as a depression in the hood that the headform bridges across.

*Wrap Around Distance (WAD)* means a distance measured from the ground reference plane to a point on the vehicle, by the use of a non-stretch flexible tape or graduated wire, with one

end held perpendicular to the ground reference plane while the tape or wire is maintained in the vehicle vertical longitudinal plane and wrapped around the vehicle front end. As specified in S6.3.1, this procedure results in identified WAD lines by using wires of different lengths, e.g., a wire of 1,000 ± 1 mm is used to identify a line at 1,000 mm from the ground reference plane. The naming conventions are to follow “WAD” with the length of the wire used for the measurement, and to refer to WAD [wire length] to refer to the line drawn by using the wire and the WAD procedure.

*S5 Performance and other requirements.*

*S5.1 Headform impact requirements.*

(a) When tested in accordance with the procedures of S6 under the conditions of S7, subject to the limits of S5.2, when any part of a vehicle within the Child Headform Test Area or Adult Headform Test Area is impacted by the headform described in S8, HIC shall not exceed 1,000 (HIC1000).

(b) The HIC in the remaining Child or Adult Headform Test Areas shall not exceed 1,700 (HIC1700), provided that the manufacturer has identified HIC1700 Area specified by S5.5(a).

*S5.2 Minimum Amount of Child and Adult Headform Test Area that must conform to HIC1000.*

(a) *HIC1000 Area in the Combined Child and Adult Headform Test Areas.* Calculate the numerical value of two thirds of the Hood Area (see S4 for the definition of Hood Area and S6.5.2 for its determination). At least this amount of area, if it can be placed within the boundary of the combined Child Headform Test Area (S6.5.3) and the Adult Headform Test Area (S6.5.4), must be HIC1000 Area. If the numerical value of two thirds of the Hood Area exceeds the Combined Child and Adult Headform Test Area, the entire Combined Child and Adult Headform Test Area must be HIC1000 Area.

(b) *HIC1000 Area in Child Headform Test Area.* Calculate the numerical value of one half of the Hood Area with less than WAD1700. At least this amount of area, when placed within the boundary of the Child Headform Test Area, must be HIC1000 Area.

*S5.3 Multiple simultaneous impact points.*

(a) If multiple simultaneous points of initial contact between the headform

and the vehicle occur in more than one area and the areas have differing HIC requirements, the more stringent requirement applies. For example, if the initial impact occurs simultaneously within a HIC1700 Area and a HIC1000 Area, the HIC1000 requirement applies. If first contact occurs simultaneously in both an Adult Headform Test Area and a Child Headform Test Area, tests with both headforms must be performed at that location.

*S5.5 Border of the HIC1700 Areas in the Hood Area.* Under the authority provided in 49 U.S.C. Chapter 301, 30166, vehicle manufacturers must make available to NHTSA the following information upon request.

(a) Manufacturers must identify HIC1700 Areas as described below, subject to S5.5(b). The HIC1700 Areas will be irrevocably selected prior to, or at the time of, certification of the vehicle. If no HIC1700 Area is provided by the manufacturer, NHTSA will test the Combined Child and Adult Headform Test Area as HIC1000 Area.

(1) Manufacturers must select HIC1700 Areas based on the (x,y) coordinates of their borders referenced from the intersection of WAD1000 and the longitudinal centerline of the vehicle. The number of coordinates and the spacing of the coordinates are provided at the discretion of the manufacturer, but the points must be joined by straight lines in the x-y plane when marking off the test areas of an actual vehicle.

(2) In lieu of (x,y) coordinates, the manufacturer may base the HIC1700 Area on registration marks referenced from the intersection of WAD1000 and the vehicle longitudinal centerline and may use decals or templates for this purpose.

(b)(1) When a HIC1700 Area is contiguous with the HIC Unlimited Margin as specified in S6.4, the lines identified by NHTSA in accordance with this standard will supersede any conflicting coordinates provided by the manufacturer, and will act as border lines in defining the HIC1700 Area.

(2) Each HIC1700 Area border line must be contiguous. However, the total HIC1700 Area may consist of an unlimited number of contiguous areas, provided that the vehicle meets the requirement for HIC1000 Area specified in S5.2.

*S5.6 Active hoods.*



(a) Under the authority provided in 49 U.S.C. 30166, upon NHTSA's request, vehicle manufacturers must make available to NHTSA information explaining the basic operational characteristics of their active hood system.

(b) Vehicles with active hoods shall meet the requirements of this standard when the hood is fully deployed. The devices to be deployed, and the minimum and maximum period of time between device deployment and impact of the headform to assure full deployment at time of impact, must be irrevocably selected by the manufacturer prior to, or at the time of, certification of the vehicle, and provided to NHTSA upon request, under the authority provided in 49 U.S.C. 30166.

(c) All reference lines, HIC Unlimited Margins, and WAD lines specified in S6.3 must be determined on the vehicle with the hood in its undeployed state. HIC1700 areas will be identified on the vehicle with the hood in its undeployed state.

(d) The impact point of the headform is determined with the hood in an undeployed position.

#### S5.7 Other movable components.

(a) Other than active devices specified in S5.6, any vehicle component (such as pop-up headlamps) that could change shape or position, and that have more than one fixed shape or position, must be stowed or retracted when determining the reference lines, margins, and WAD lines specified in S6.3.

(b) The impact point of the headform is determined when the active devices are in their stowed or retracted position.

#### S6 Test Procedures.

S6.1 Demonstrate compliance with S5.1 of this standard in accordance with the test procedures specified in this standard, under the conditions of S7, using the headforms described in S8. These procedures are used to identify the Leading Edge Reference Line, Side Reference Lines, Rear Reference Line, and the WAD lines (S6.3). These lines are used to identify Hood Area and subsequently the minimum requisite HIC1000 Area that must be provided. The lines are also used to identify HIC Unlimited Margins (S6.4) and to identify the Child Headform Test Area (S6.5.3) and the Adult Headform Test Area (S6.5.4). NHTSA may request information from the manufacturer in order to identify the HIC1700 areas (S5.5). The headform is launched at the hood (S6.6). The child headform must impact within the Child Headform Test Area and the adult headform must impact within the Adult Headform Test

Area. When a headform strikes a HIC1000 Area, the HIC measured by the headform must not exceed 1000. When it strikes a HIC 1700 area, HIC must not exceed 1700.

#### S6.2 [Reserved]

S6.3 *Determining reference lines on the vehicle.* Subject to S6.3.5, the reference lines are determined on the vehicle as follows.

S6.3.1 *WAD lines.* Determine WAD lines by connecting the end points of a non-stretch flexible wire as it is traversed across the front of the vehicle. During this process, the wire must remain in a vertical longitudinal vehicle plane and held taut. One end of the wire must be held at the ground reference level, vertically  $\pm 1$  degree, below the front end of the vehicle, and the other end held in contact with the hood or fender (see figure 2, provided for illustration purposes). Determine WAD lines using wires of  $1000 \pm 1$  mm (the line is referred to as WAD1000),  $1700 \pm 1$  mm (WAD1700) and of  $2100 \pm 1$  mm (WAD2100).

#### S6.3.2 *Leading Edge Reference Line.*

(a) *Default procedure.* Determine the Leading Edge Reference Line by connecting the points of contact between a straight edge  $1000 \pm 1$  mm long and the front surface of the vehicle as the straight edge is traversed laterally across and is in contact with the front end of the vehicle (see figure 3, provided for illustration purposes). During this process, the straight edge must be held in a vertical longitudinal vehicle plane, inclined rearwards by  $40 \pm 1$  degree from the horizontal, and with the lower end  $600 \pm 5$  mm above the ground reference plane. If the straight edge makes a continuous contact or makes multiple contacts on the vehicle when the straight edge is at a single lateral location, rerun the procedure with the straight edge inclined rearwards at an angle of  $50 \pm 1$  degree from the horizontal. For the purpose of determining whether the straight edge should be held at  $50 \pm 1$  degree from the horizontal, contacts with a straight edge will be considered continuous if the total length of contact along the straight edge is greater than 50 mm and the deviation of the contact surface from the straight edge is less than 0.5 mm. Additionally, contact points must be separated by at least 50 mm in order to be considered multiple points of contact. If this procedure results in multiple or continuous points of contact even after inclining the straight edge rearwards at an angle of  $50 \pm 1$  degree from the horizontal, determine the Leading Edge Reference Line using the most forward contact.

(b) *Low front vehicles.* If the vehicle exterior geometry is such that the bottom end of the straight edge makes first contact with the vehicle, that contact point is used to determine the Leading Edge Reference Line at that lateral position. See figure 4, provided for illustration purposes.

(c) *High front vehicles.* If the vehicle exterior geometry is such that the top end of the straight edge makes first contact with the vehicle, then the WAD1000 line will be used as the Leading Edge Reference Line at that lateral position. If the WAD1000 line does not intersect the Side Reference Line determined in S6.3.3 such that the corner reference point of the Hood Top does not exist, connect the two lines using the following procedure.

(1) Find the corner reference point of the Hood Top, as if the Leading Edge Reference Line were determined by the top end of the straight edge, rather than WAD1000. If this point does not exist, find the corner reference point of the Hood Top, as if the Leading Edge Reference Line were determined by the straight edge held at any height.

(2) Span the distance between the corner reference point of the Hood Top and the WAD1000 line with a non-stretch flexible wire held taut in the vertical longitudinal plane.

(3) Fill the discontinuity by establishing a line created by the projection of the wire horizontally rearward onto the vehicle surface.

S6.3.3 *Side Reference Lines.* These lines are determined on the vehicle by connecting the points of contact between a straight edge  $700 \pm 1$  mm long and the vehicle, as the straight edge is traversed fore or aft, in contact with the sides of the vehicle (see figure 5, provided for illustration purposes). During this process, the straight edge must be held in a vertical transverse vehicle plane, inclined inwards by  $45 \pm 1$  degrees from the horizontal. If this procedure results in multiple or continuous points of contact on the vehicle when the straight edge is at a single fore-aft location, determine the Side Reference Line by using the most outboard contact.

#### S6.3.4 *Rear Reference Line.*

(a) *Default procedure.* This line is determined on the vehicle by connecting the most rearward points on the hood that contact a  $165 \pm 1$  mm diameter hemisphere as it is traversed laterally across the vehicle while maintaining contact with the windshield (see figure 6, provided for illustration purposes). The wiper blades, linkages, and arms are removed during this process. If this procedure results in multiple or continuous points of contact

on the vehicle when the hemisphere is at a single lateral location, determine the Rear Reference Line by using the most rearward contact. This section is subject to S6.3.4(b).

(b) *Revision of a Rear Reference Line when not intersecting with a Side Reference Line.*

(1) Where the rear reference line and the side reference line do not intersect, the rear reference line must be extended and/or modified using a semi-circular template of radius  $100 \pm 1$  mm. The template must be made of a thin flexible sheet material that easily bends to a single curvature in any direction. The template must resist double or complex curvature where this could result in wrinkling. The template is marked with four points "A" through "D," as shown in figure 8 (provided for illustration purpose), while the template is on a flat surface.

(2) The template must be placed on the vehicle with Corners "A" and "B" coincident with the Side Reference Line. Ensuring these two corners remain coincident with the Side Reference Line, the template must be slid progressively rearwards until the outer edge of the template makes first contact with the Rear Reference Line.

Throughout the process, the template must be curved to follow, as closely as possible, the outer contour of the vehicle's hood and fender without wrinkling or folding of the template. If the first point of contact between the template and Rear Reference Line lies outside the arc identified by points "C" and "D," the Rear Reference Line is extended and/or modified to follow the circumferential arc of the template to meet the Side Reference Line, as shown in figure 9 (provided for illustration purposes).

(3) *Larger template.* If the outer edge of the template of S6.34(b)(1) cannot make contact with the Rear Reference Line while simultaneously the Side Reference Line contacts points "A" and "B," or the point at which the Rear Reference Line and template make first contact lies within the arc identified by points "C" and "D," then additional templates will be used where the radii are increased progressively in increments of 20 mm, until all the criteria of S6.3.4(b)(2) are met.

S6.3.5 *Adjustments to the procedures determining the reference lines.*

(a) *Line discontinuity.* If the Leading Edge Reference Line, Side Reference Line(s) or Rear Reference Line are discontinuous (*i.e.*, the procedure has resulted in a gap in a line), the discontinuity will be spanned by the following method. Connect the two

points separated by the discontinuity with a non-stretch flexible wire held taut. Fill the discontinuity by establishing a line created by the projection of the wire vertically downward onto the hood surface.

(b) *Hood ornaments.* If the vehicle is fitted with a badge, emblem, hood ornament, or other structure which would bend back or retract under an applied load of maximum  $100 \pm 5$  N, apply this load while the reference lines are defined on the hood. The load must be released prior to testing with a headform.

S6.4 *HIC Unlimited Margins.*

S6.4.1 *HIC Unlimited Margin of the Rear Reference Line.* The HIC Unlimited Margin of the Rear Reference Line is the line that is forwardmost of the following two lines.

(a) The line on the vehicle determined by connecting the points of contact between a non-stretch flexible wire measuring  $82.5 \pm 0.5$  mm long as it is traversed along the Rear Reference Line. During this process, the wire remains in a vertical longitudinal vehicle plane and held taut. One end of the wire is held in contact with the Rear Reference Line and the other end is held in contact with the vehicle at points forward of the Rear Reference Line.

(b) The WAD2100 Line.

S6.4.2 *HIC Unlimited Margin of the Leading Edge Reference Line.* The HIC Unlimited Margin of the Leading Edge Reference Line is the line that is rearmost of the following two lines.

(a) The line on the vehicle determined by connecting the points of contact between a non-stretch flexible wire measuring  $82.5 \pm 0.5$  mm long as it is traversed along the Leading Edge Reference Line. During this process, the wire remains in a vertical longitudinal vehicle plane and held taut. One end of the wire is held in contact with the Leading Edge Reference Line and the other end is held in contact with the vehicle and points rearward of the Leading Edge Reference Line.

(b) The WAD1000 Line.

S6.4.3 *HIC Unlimited Margin of the Side Reference Lines.* This HIC Unlimited Margin is the line determined by connecting the points of contact between a non-stretch flexible wire measuring  $82.5 \pm 0.5$  mm long as it is traversed along the Side Reference Line. During this process, the wire remains in a vertical lateral plane and held taut. One end of the wire is held in contact with the Side Reference Line and the other end held is in contact with the vehicle and points inward of the Side Reference Line.

S6.5 *Hood Top, Hood Area, Child Headform Test Area and Adult*

*Headform Test Area border lines and computation method.* The border lines for the Hood Top, Hood Area, the Child Headform Test Area, and the Adult Headform Test Area are identified as described in this section. Computation of these areas is made on the basis of a two-dimensional projection of these areas on to a horizontal vehicle plane. These areas include those comprised of any "non-contactable surfaces" (as defined in S4) in their computation.

S6.5.1 *Hood Top.* This area is enclosed by the intersection of the following borders:

(a) *Front border:* Leading Edge Reference Line;

(b) *Side border:* Side Reference Lines.

(c) *Rear border:* Rear Reference Line.

S6.5.2 *Hood Area.* This area is enclosed by the intersection of the following borders:

(a) *Front border:* the Leading Edge Reference Line or the WAD1000 line, whichever is most rearward at the point of measurement;

(b) *Side border:* Side Reference Lines.

(c) *Rear border:* Rear Reference Line, or the WAD2100 line, whichever is most forward at the point of measurement.

S6.5.3 *Child Headform Test Area.*

This area is enclosed by the intersection of the following borders:

(a) *Front border:* HIC Unlimited Margin of the Leading Edge Reference Line.

(b) *Side borders:* HIC Unlimited Margins of the Side Reference Lines.

(c) *Rear border:* WAD1700 line or the HIC Unlimited Margin of the Rear Reference Line, whichever is most forward at the point of measurement.

S6.5.4 *Adult Headform Test Area.*

This area is enclosed by the intersection of the following borders:

(a) *Front border:* WAD1700 line.

(b) *Side borders:* HIC Unlimited Margins of the Side Reference Lines.

(c) *Rear border:* HIC Unlimited Margin of the Rear Reference Line.

S6.6 *Headform launch procedures.*

(a) *Propulsion of the headform.* The headform must be in free flight at the moment of impact. The headform velocity at the time of impact must be  $9.7 \pm 0.2$  meters per second (m/s) for both the child and adult headforms.

(b) *Child headform test procedure.*

(1) At least one impact point against which the child headform contacts must be in the Child Headform Test Area.

(2) The velocity vector of the headform center of mass at impact is in a longitudinal vertical vehicle plane at an angle of  $50 \pm 2^\circ$  to the horizontal directed downward and rearward.

(c) *Adult headform test procedure.*

(1) At least one impact point against which the adult headform contacts must be in the Adult Headform Test Area.

(2) The velocity vector of the headform center of mass at impact is in a longitudinal vertical vehicle plane at an angle of  $65 \pm 2^\circ$  to the horizontal directed downward and rearward.

**S7. General test conditions.**

**S7.1 Humidity and temperature.** At the time of testing, the ambient air at the test site must have a relative humidity of  $40 \text{ percent} \pm 30 \text{ percent}$  and a temperature of  $20 \pm 4^\circ\text{C}$ .

**S7.2 Test site.** The test site is on a ground reference plane consisting of a flat, smooth and hard surface with a grade not exceeding 1 percent.

**S7.3. Vehicle preparation.**

(a) *Normal ride attitude.* The vehicle is positioned on the ground reference plane, loaded to its unloaded vehicle weight, and tires inflated to the pressures listed on the vehicle's FMVSS No. 110 (49 CFR 571.110) placard. The front wheels are aligned to be parallel to the vehicle vertical longitudinal plane, the suspension set to the normal running condition as specified by the manufacturer for a speed of 40 km/hr, and the parking brake applied.

(b) *Additional mass.* Place a  $75 \pm 5 \text{ kg}$  mass at each most outboard front row seat. The fore-aft position of a loaded seat must be set at the mid-track position. If there is no notch at the mid-track position, the seat is set at the notch closest to and rearward of mid-track, with respect to the direction the seat is facing. Set the seat back angle to a position between the most upright position intended for occupancy to 10 degrees rearward of that position, with respect to the direction the seat is facing.

(c) *Movable front-end vehicle components.*

(1) *Active hoods and devices.* Active hoods, external air bags, and other devices designed to protect pedestrians are deployed prior to launching the headform.

(2) *Other movable components.* Other than active devices specified in S6.3, any vehicle component (such as pop-up headlamps) that could change shape or position, and that have more than one fixed shape or position, are adjusted to any fixed shape or position prior to launching the headform.

**S8. Headform specifications**

(a) *Dynamic performance requirements.*

(1) *Qualification.* The headforms must meet the dynamic qualification requirements specified in S8.4.

(2) *First natural frequency.* The first natural frequency of the headforms must be over 5000 Hz.

**S8.1 Construction.**

(a) The child and adult headforms are made of aluminum, are of homogenous

construction and are hemispherical in shape. The headforms are schematically represented in figures 11 and 12 and detailed mechanical drawings are provided in figures 13–26. The overall diameter of the headforms are  $165 \pm 1 \text{ mm}$ .

(b) *Mass properties of child headform (figure 13).* The mass of the child headform is  $3.5 \pm 0.07 \text{ kg}$ . The moment of inertia about an axis through the center of gravity and perpendicular to the direction of impact is within the range of  $0.008 \text{ to } 0.012 \text{ kgm}^2$ . The center of gravity of the headform including instrumentation is located in the geometric center of the sphere with a tolerance of  $\pm 2 \text{ mm}$ .

(c) *Mass properties of adult headform (figure 20).* The mass of the adult headform is  $4.5 \pm 0.1 \text{ kg}$ . The moment of inertia about an axis through the center of gravity and perpendicular to the direction of impact is within the range of  $0.010 \text{ to } 0.013 \text{ kgm}^2$ . The center of gravity of the headform including instrumentation is located in the geometric center of the sphere with a tolerance of  $\pm 5 \text{ mm}$ .

(d) *Cover (figures 15 and 22).* The headforms are covered with a  $14 \pm 0.5 \text{ mm}$  thick synthetic skin, which must cover at least half of the hemisphere.

(e) *Back plate (figures 17 and 24).* The headforms each have a rear flat face perpendicular to the direction of travel and the axis of one of the accelerometers. The flat face provides access to the accelerometers and serves as an attachment point for the propulsion system.

**S8.2 Instrumentation mount.** A recess within the headforms allows for mounting three uniaxial accelerometers. For each accelerometer, the seismic mass is located within  $\pm 5 \text{ mm}$  of the headform's centroid as measured along its measurement axis, and within  $\pm 0.5 \text{ mm}$  as measured perpendicular to its measurement axis.

**S8.3 Instrumentation.**

(a) Three uniaxial accelerometers are installed within the headforms. One of the accelerometers has its sensitive axis perpendicular to mounting face A (see figures 11 and 12) and its seismic mass is positioned within a cylindrical tolerance field of 1 mm radius and 20 mm length. The centerline of the tolerance field runs perpendicular to the mounting face and its mid-point coincides with the spheroidal center of the headform.

(b) The remaining accelerometers have their sensitive axes perpendicular to each other and parallel to mounting face A and their seismic masses are positioned within a spherical tolerance field of 10 mm radius. The center of the

tolerance field coincides with the spheroidal center of the headform.

(c) The accelerometers have the dimensions, response characteristics, and sensitive mass locations specified in drawing SA572–S5 (figure 27). The instrumentation response value Channel Frequency Class (CFC), as defined in SAE J211 (2022), "Instrumentation for Impact Test," (incorporated by reference, see § 571.5), is CFC 1000.

**S8.4 Qualification requirements**

(a) *Peak acceleration.* For each of the three drop tests prescribed in S8, the peak resultant acceleration in the headform must be:

- (1) for the child headform, not less than 245 g and not more than 300 g;
- (2) for the adult headform, not less than 225 g and not more than 275 g.

(b) *Unimodal response.* For each of the three drop tests, the acceleration must be unimodal to the extent that oscillations occurring after the main acceleration pulse are less than ten percent (zero to peak) of the main pulse.

(c) *Off-axis sensitivity.* The lateral acceleration must not exceed 15 g (zero to peak).

**S8.5 Qualification procedure**

(a) *Temperature and humidity.* The headforms must have a temperature of  $20 \pm 2^\circ\text{C}$ . The temperature tolerances apply at a relative humidity of  $40 \pm 30 \text{ percent}$  after a soak period of at least four hours prior to their application in a test.

(b) *Drop test.* (1) *Drop rig.* The headform is suspended from a drop rig as shown in figure 12 (provided for illustration purposes) and released by a means to ensure that it does not rotate during the fall. The headform is set up to strike a rigidly supported flat horizontal steel plate, over 50 mm thick and over 300 x 300 mm square with a surface finish of between 0.2 and 2.0 micrometers. The plate is  $\pm 0.5$  degrees from horizontal. The headform skin outer surface and the surface of the steel plate are cleaned with 1,1,1 trichloroethane or equivalent and allowed to dry.

(2) *Drop angle.* The headform must be oriented as shown in figure 10 (provided for illustration purposes) with the rear face of the headform at the following angles from the vertical:

- (i)  $50 \pm 2$  degrees for the child headform;
- (ii)  $65 \pm 2$  degrees for the adult headform.

(3) *Drop height.* The headform is dropped from a height of  $376 \pm 1 \text{ mm}$ .

(i) *Initial drop.* The drop is performed with the headform oriented such that the plane formed by the travel direction vector and the symmetric axis of the headform is perpendicular within  $\pm 2$

degrees to the sensitive axis of one of the accelerometers.

(ii) *Repeat drops.* The drop test is performed two additional times, with

the headform rotated 120° around its symmetrical axis after each test with a two-hour wait period between tests.

BILLING CODE 4910-59-P

[Figures to FMVSS No. 228, 49 CFR 571.228]

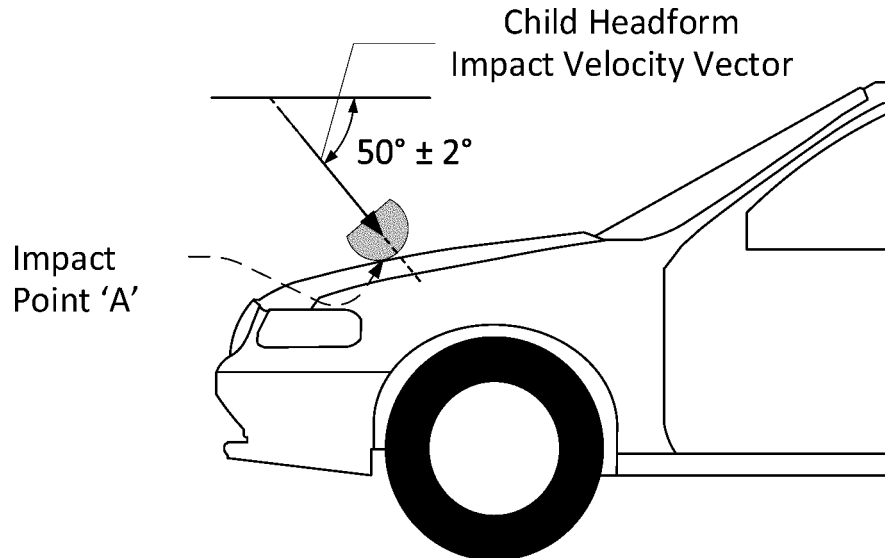

Figure 1. Impact point.  
For illustration purposes only.

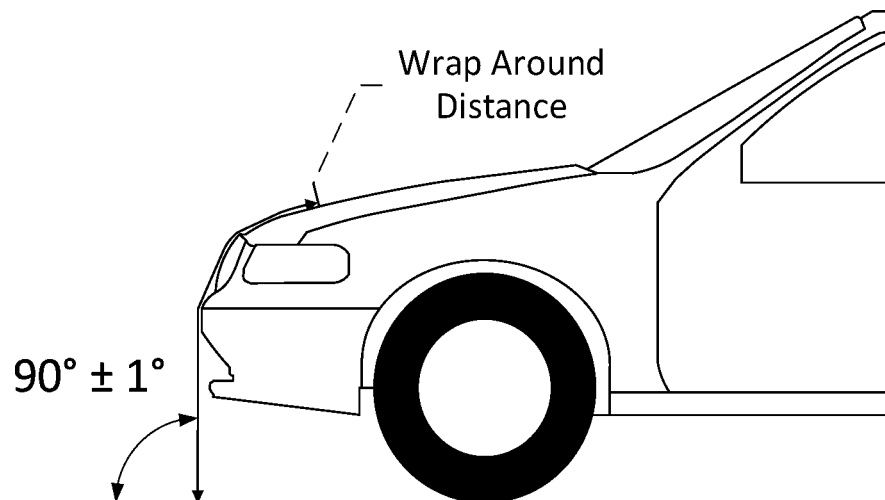

Figure 2. Wrap Around Distance measurement.  
For illustration purposes only.

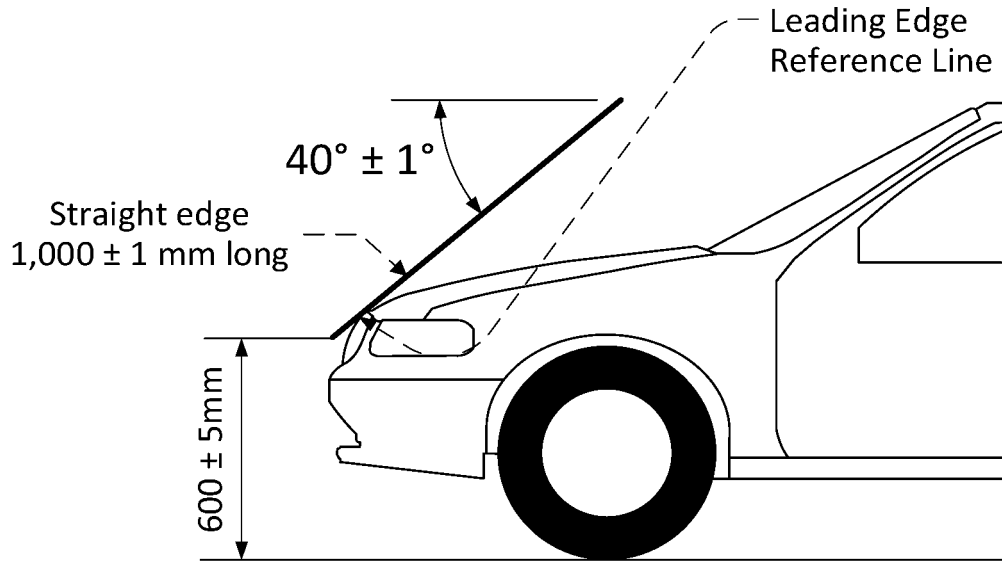

Figure 3. Leading edge reference line  
For illustration purposes only.

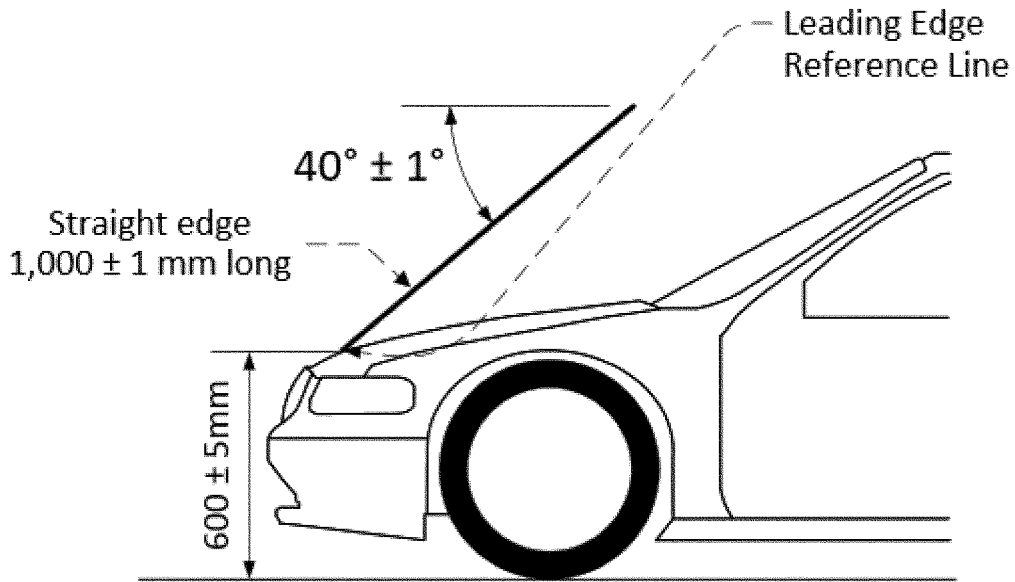

Figure 4. Leading Edge Reference Line for Low Front Vehicles.  
For illustration purposes only.

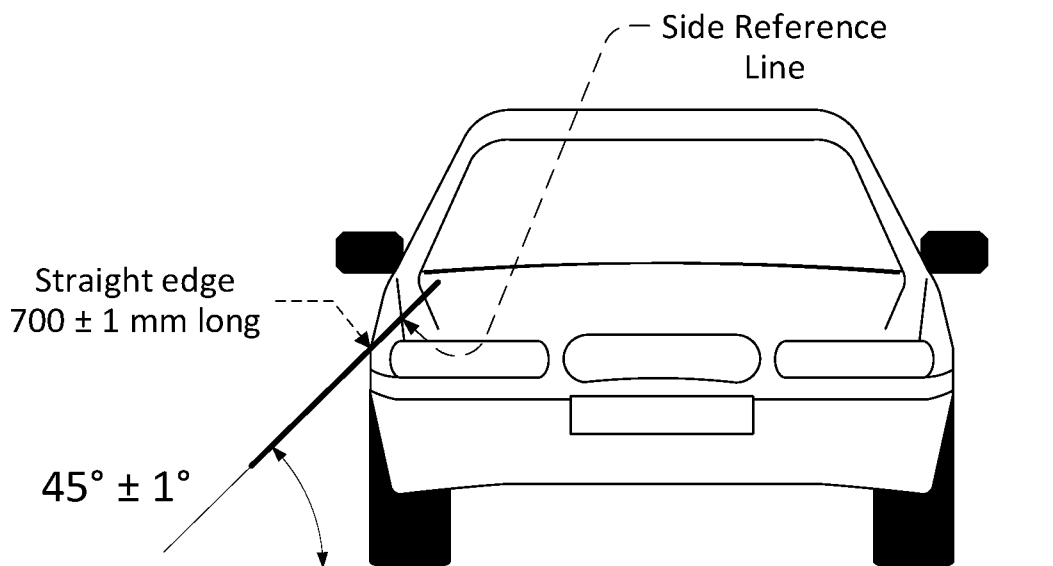

Figure 5. Side reference line.  
For illustration purposes only.

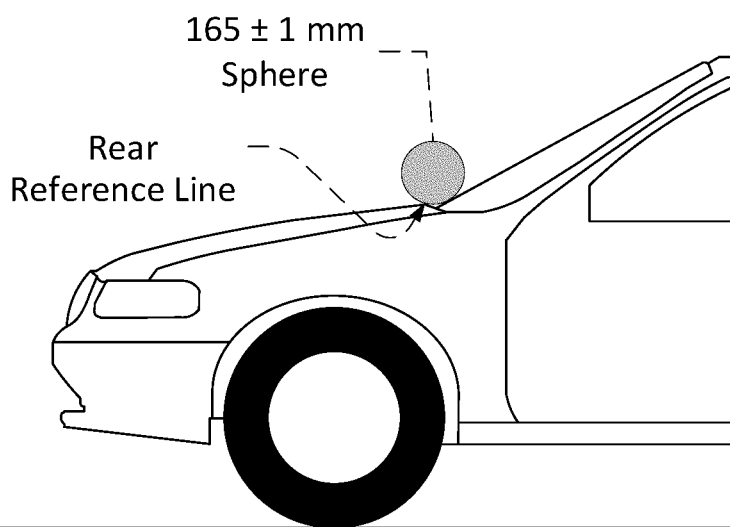

Figure 6. Rear reference line.  
For illustration purposes only.

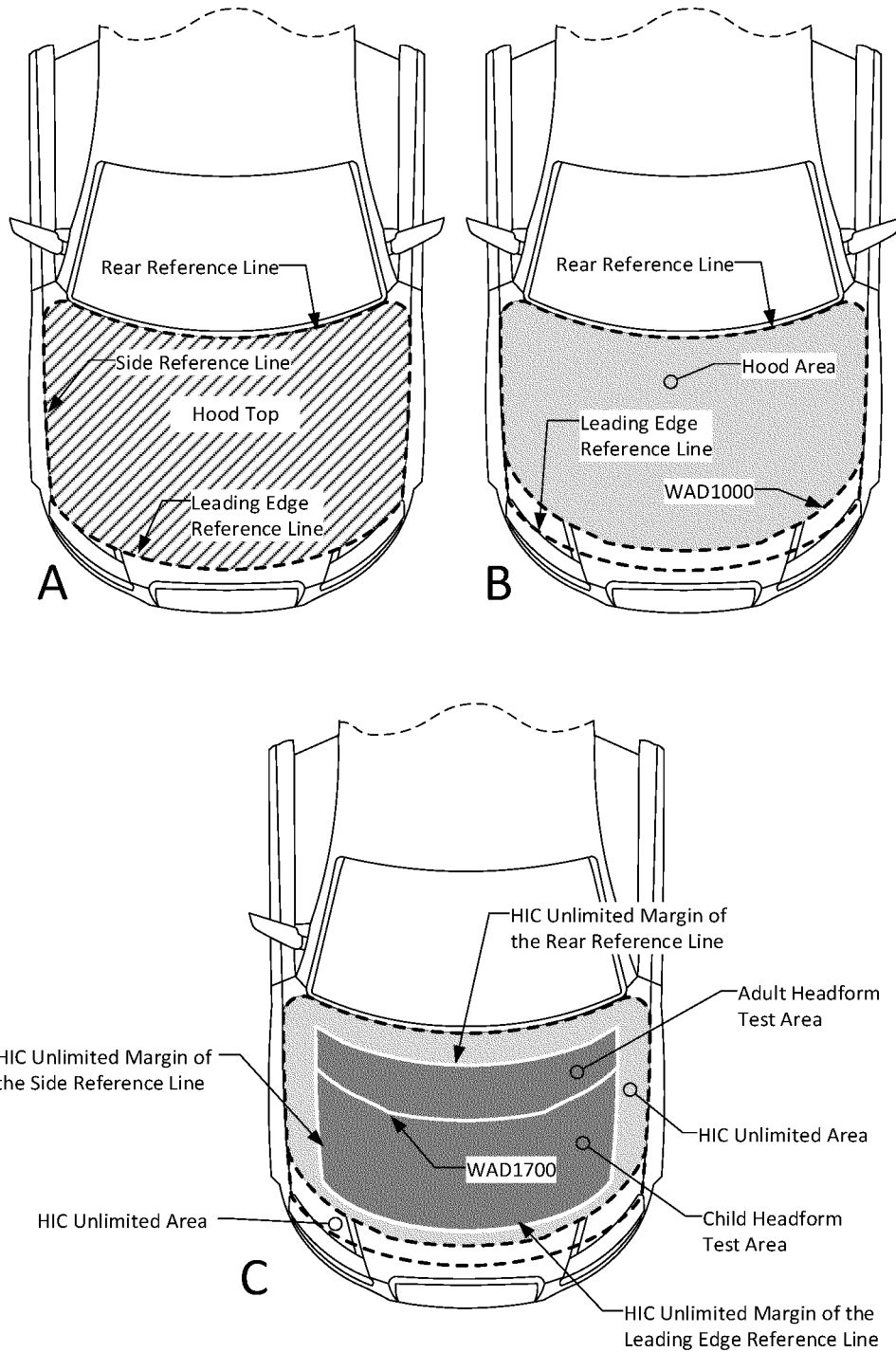

Figure 7. Example marking of reference lines for Hood Top (A), Hood Area (B), Test Areas, HIC Unlimited Areas (C), Child and Adult Headform Test Areas (C). For illustration purposes only

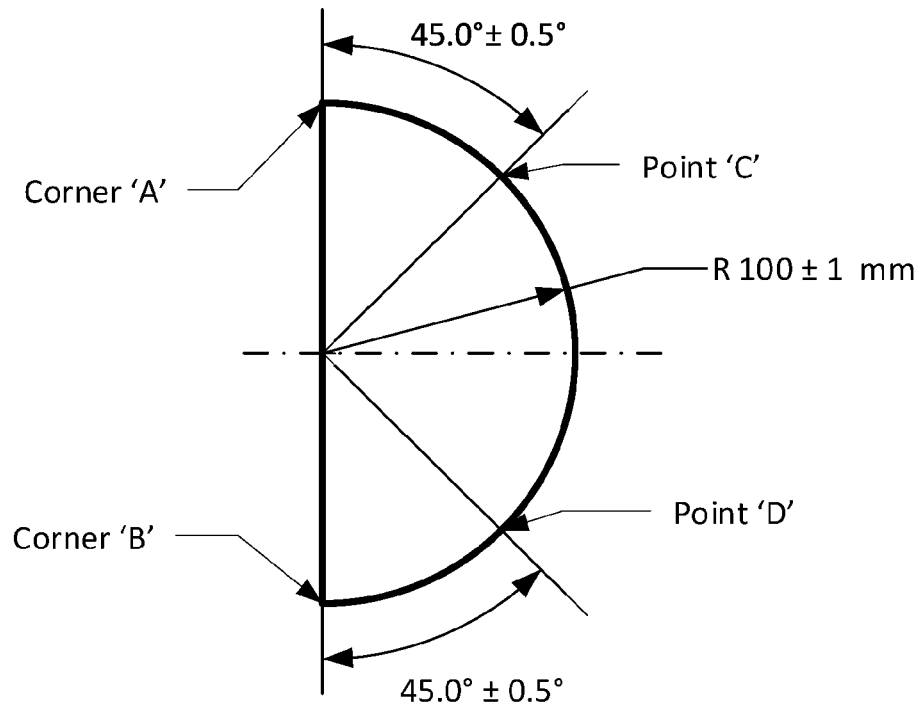

Figure 8. Template used to revise a non-intersecting rear reference line.

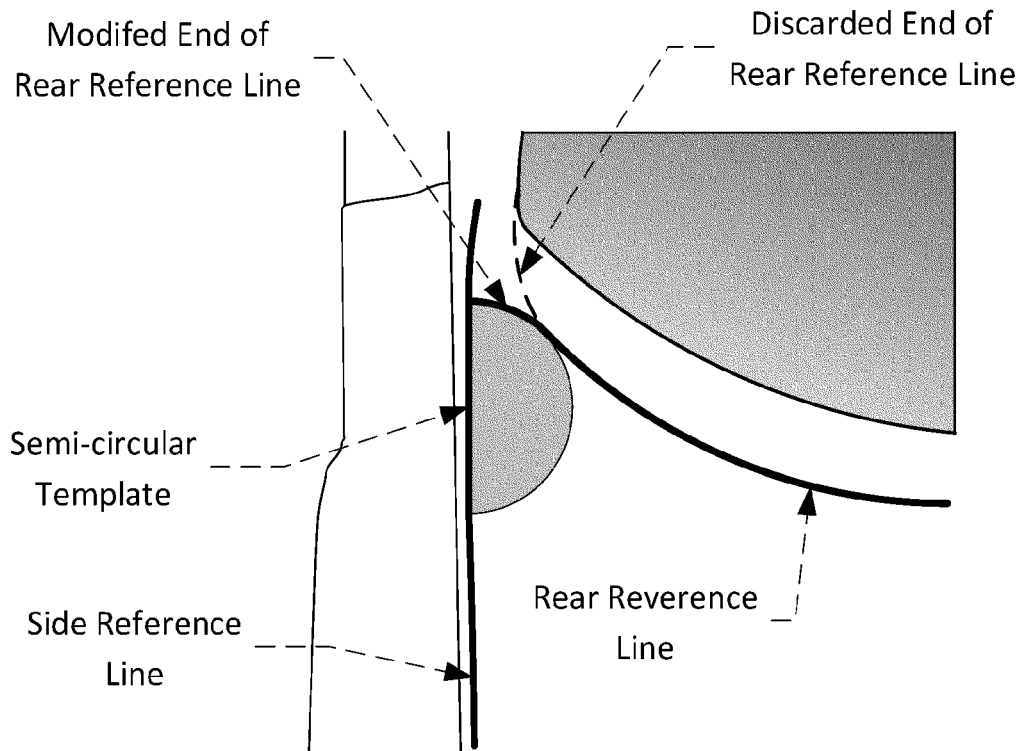

Figure 9. Marking of intersection between rear and side reference lines.  
For illustration purposes only.



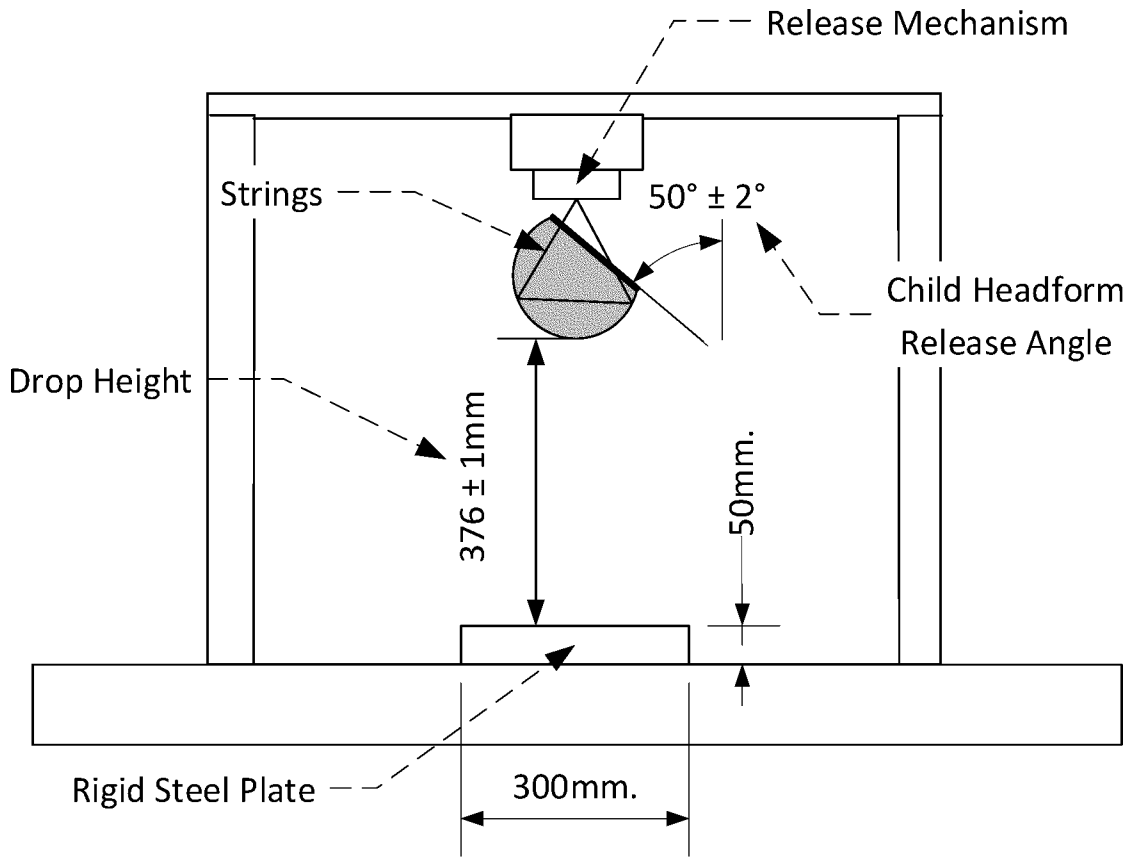

Figure 10. Test set-up for dynamic headform qualification test.  
For illustration purposes only.

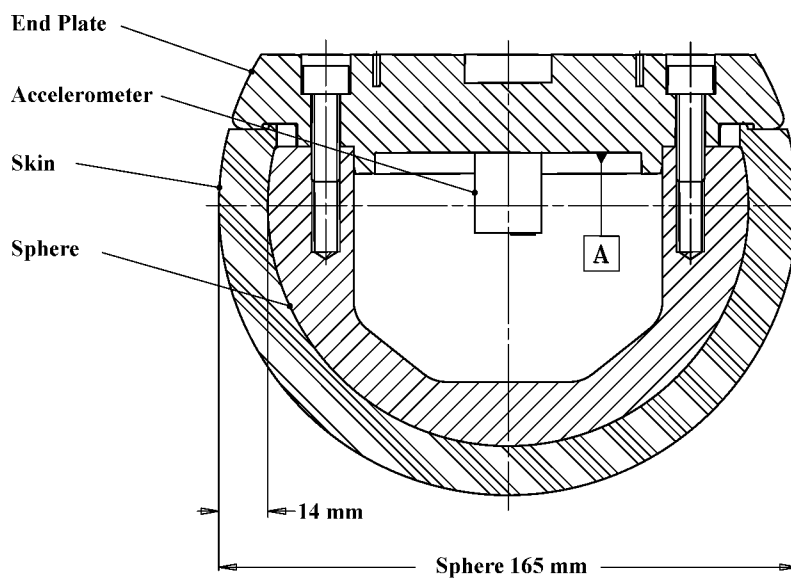

Figure 11 – Child Headform Assembly Schematic

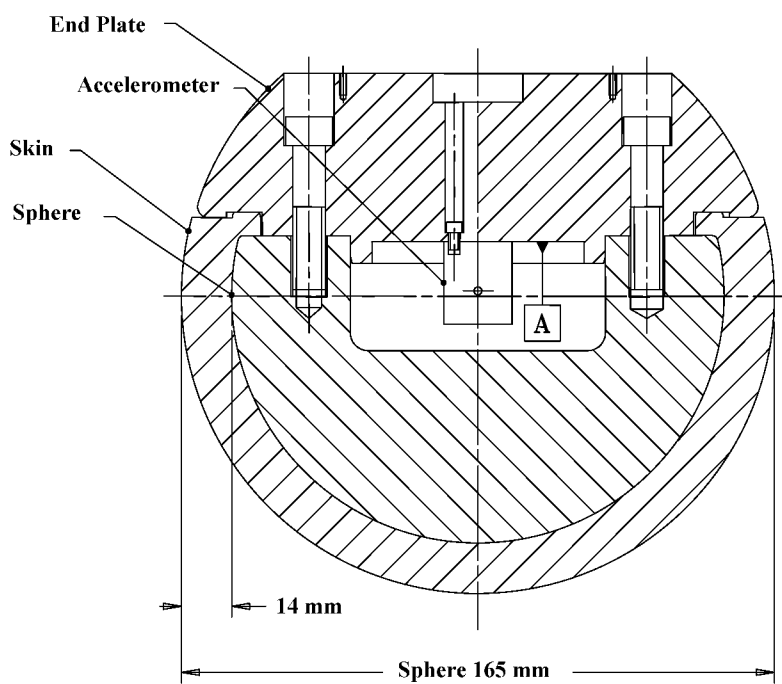

Figure 12 – Adult Headform Assembly Schematic

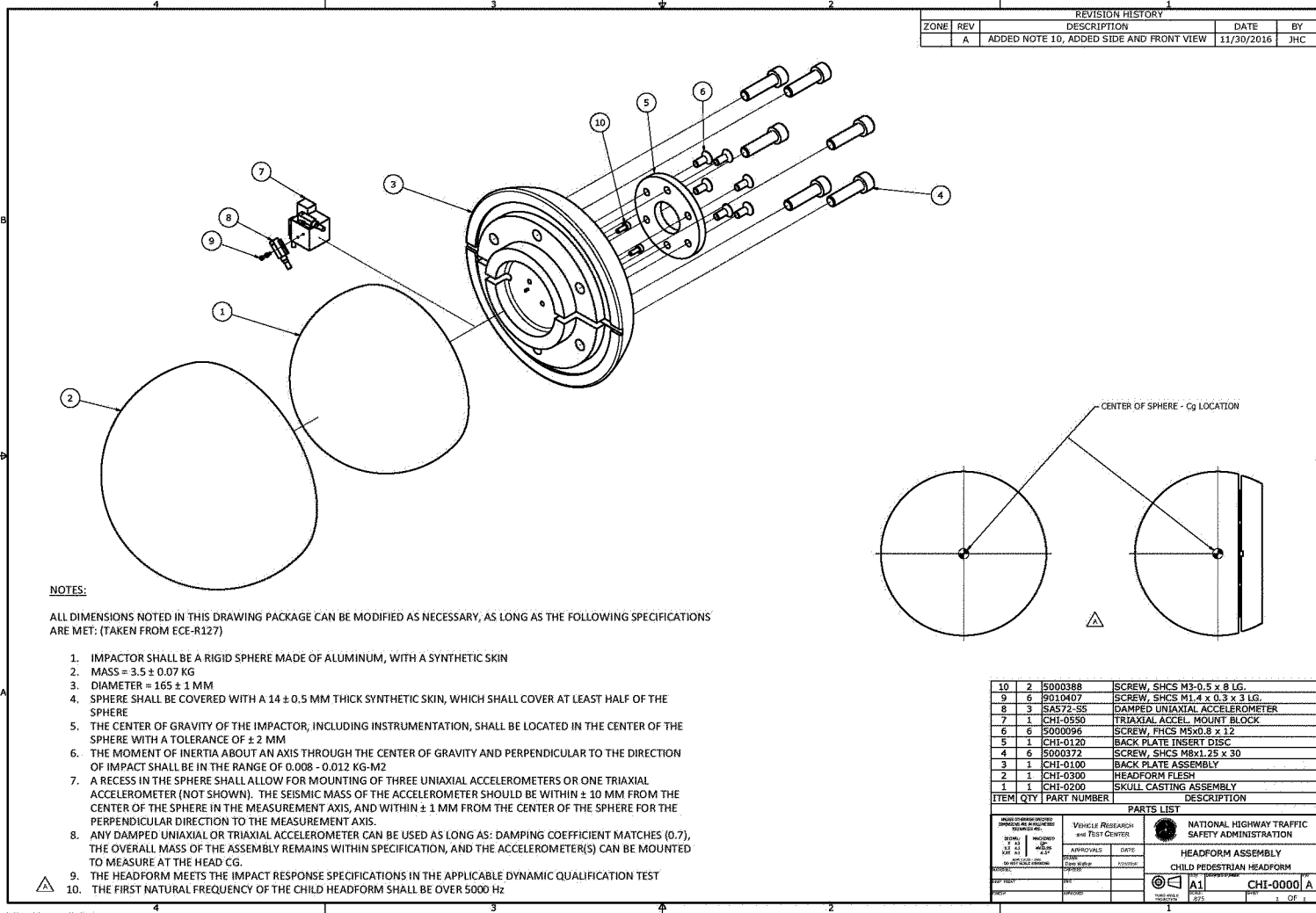

Figure 13 – Child Headform Assembly Drawing 1

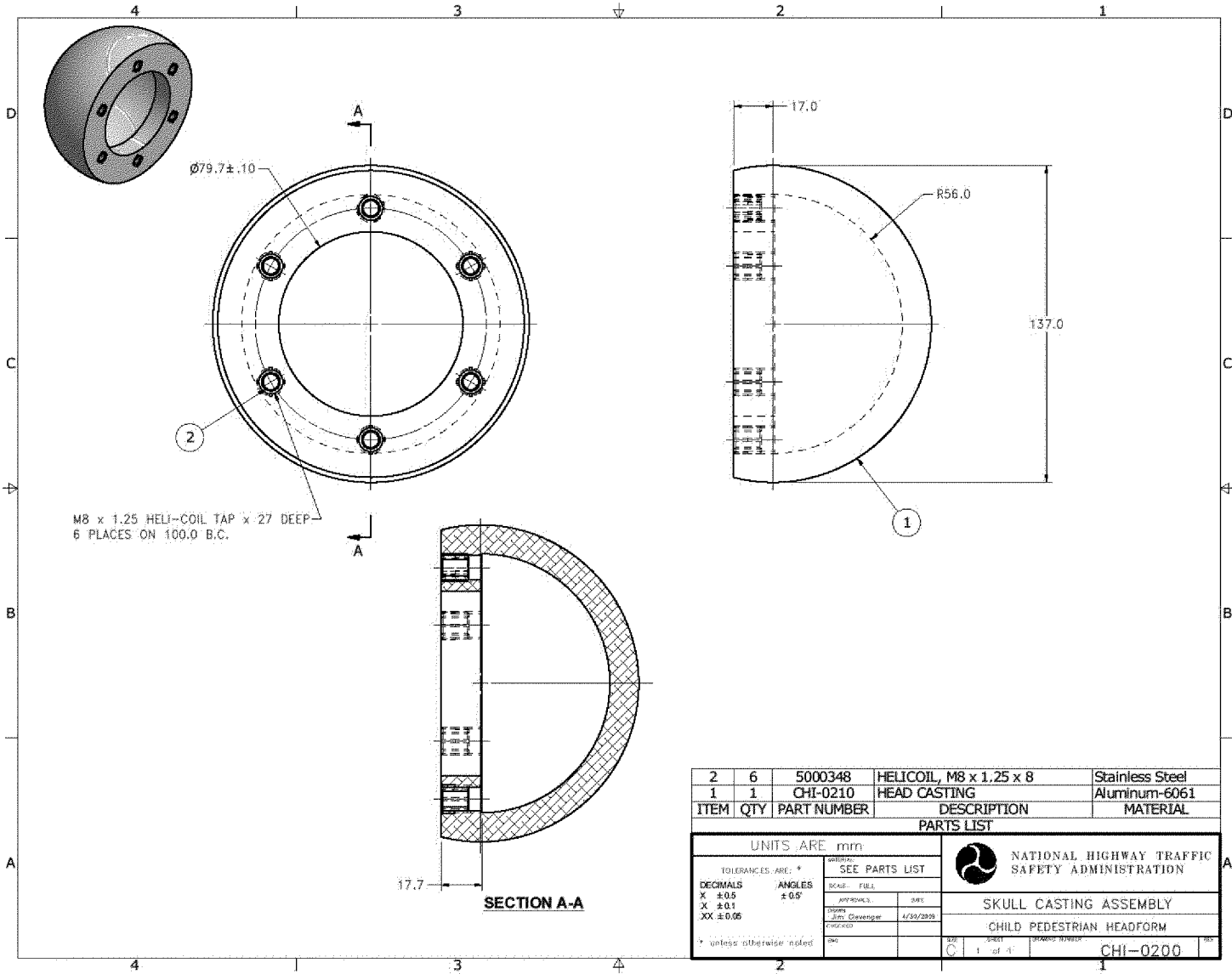

Figure 14 - Child Headform Drawing 2

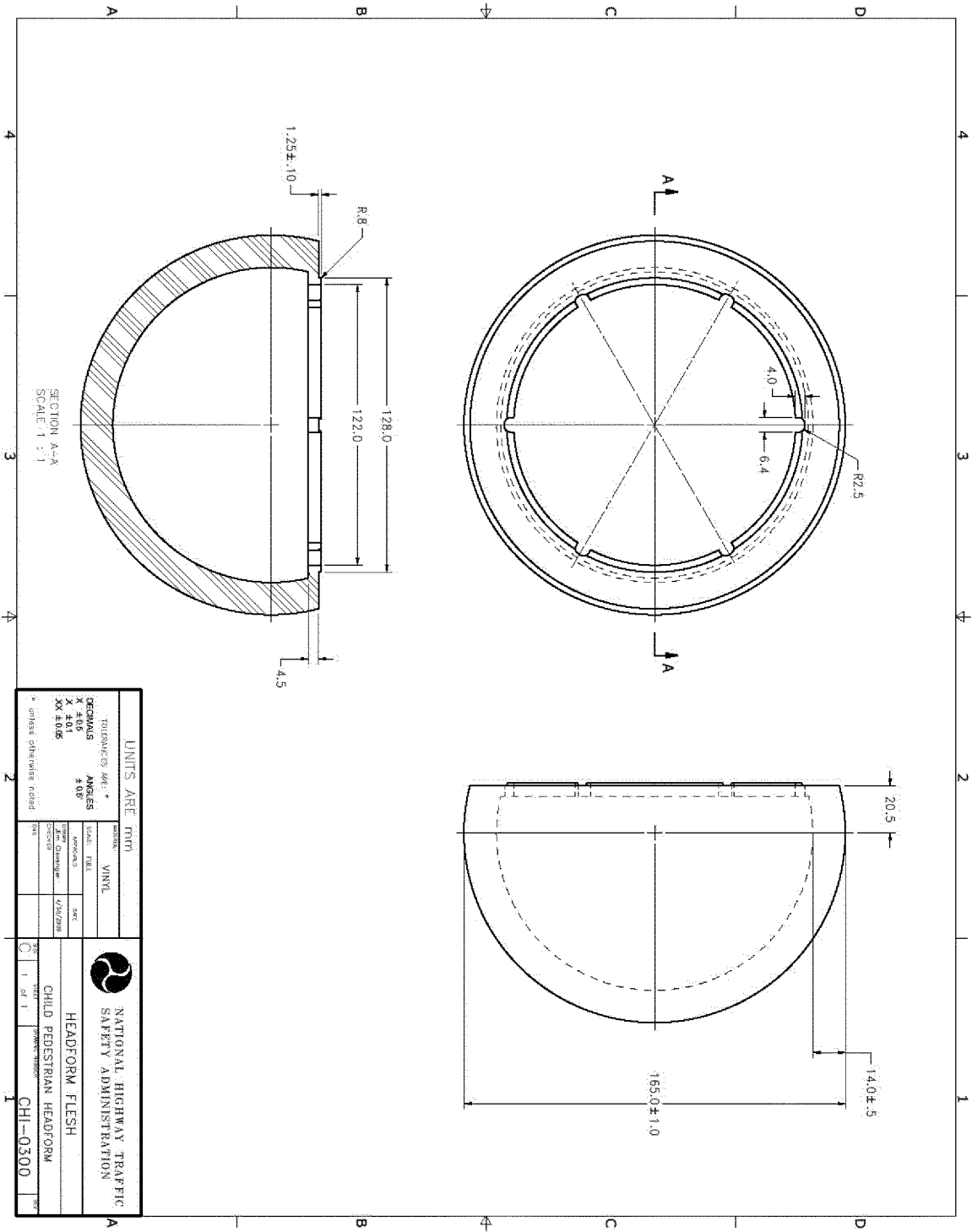

Figure 15 - Child Headform Drawing 3

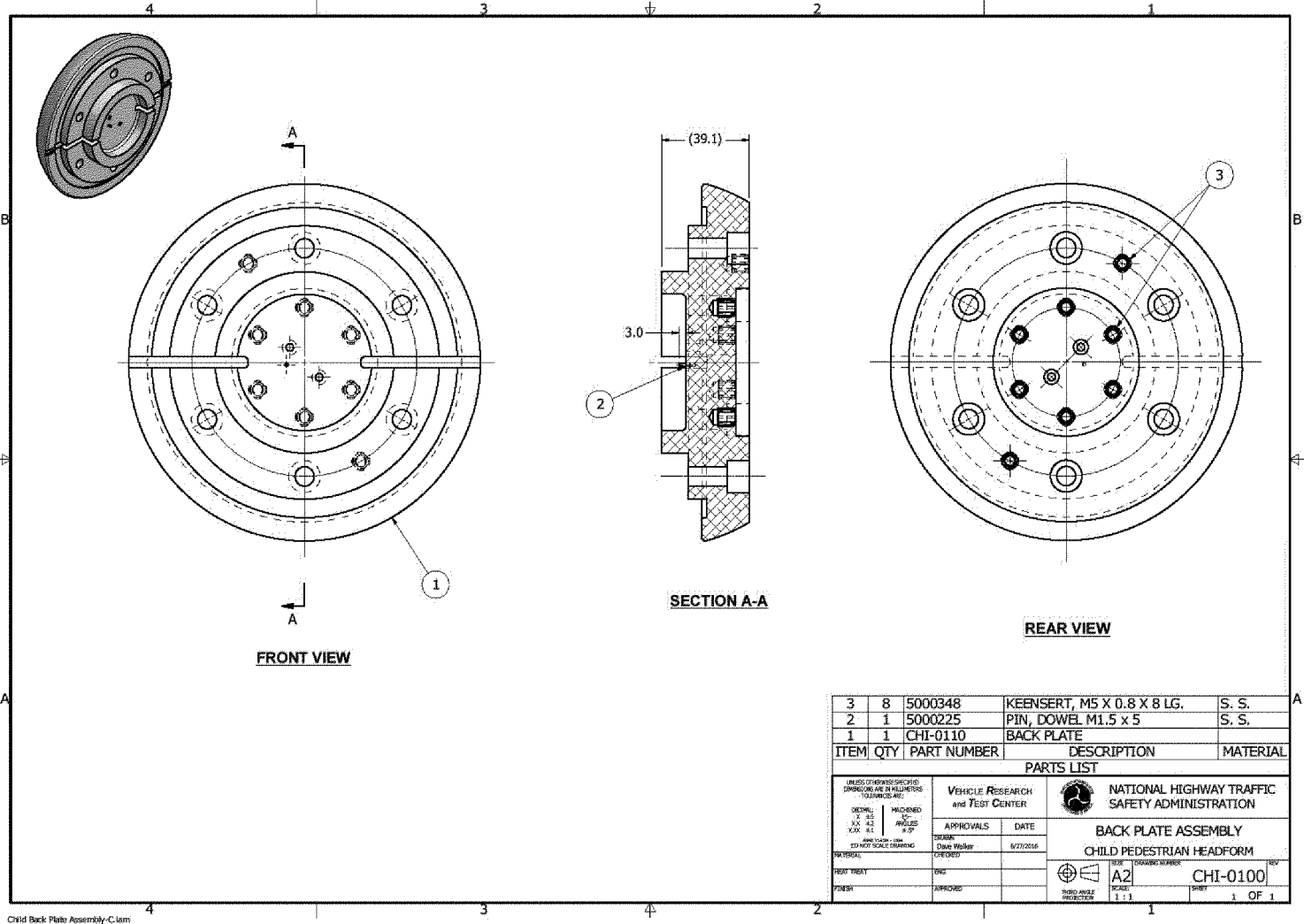

Figure 16 - Child Headform Drawing 4

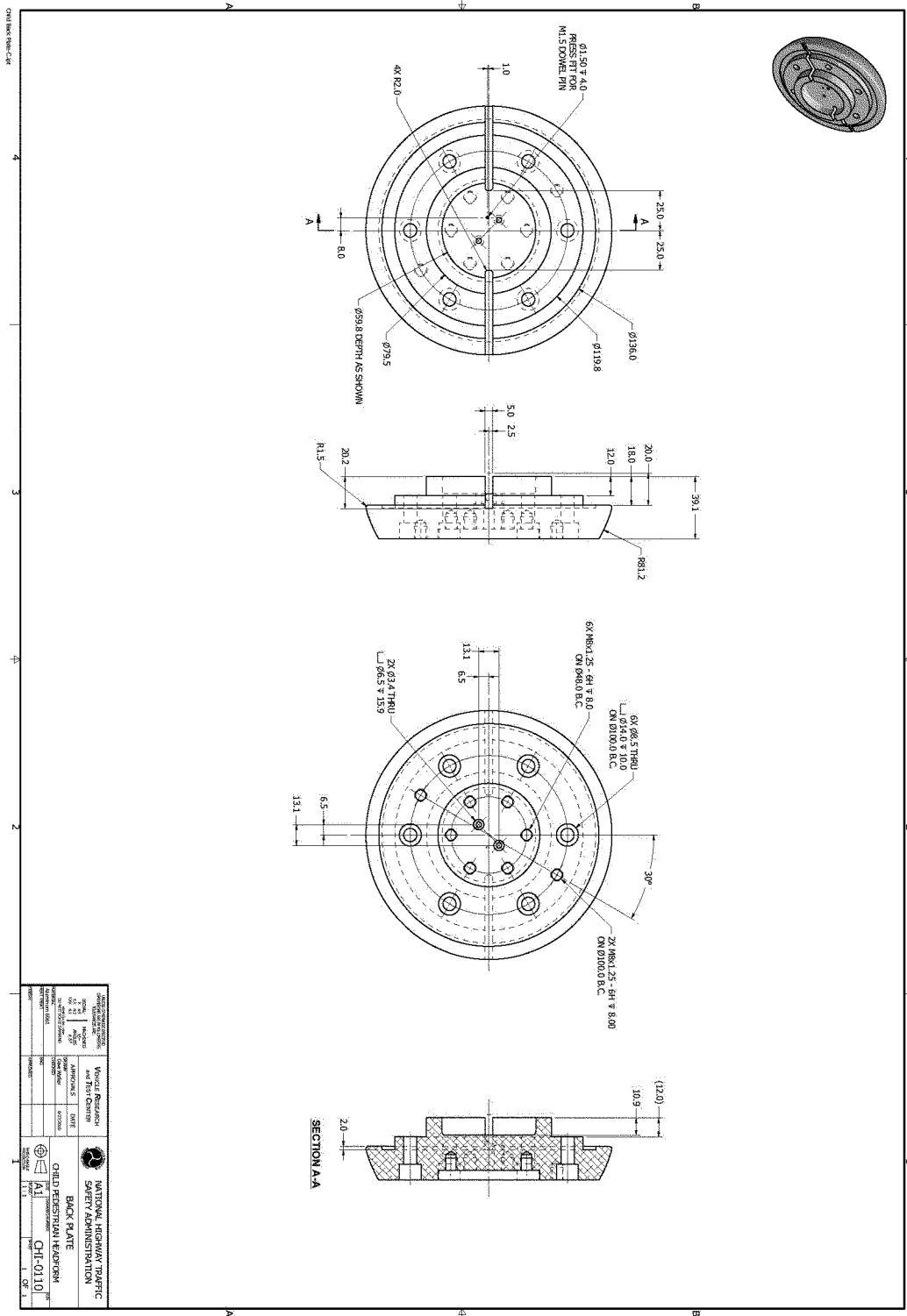
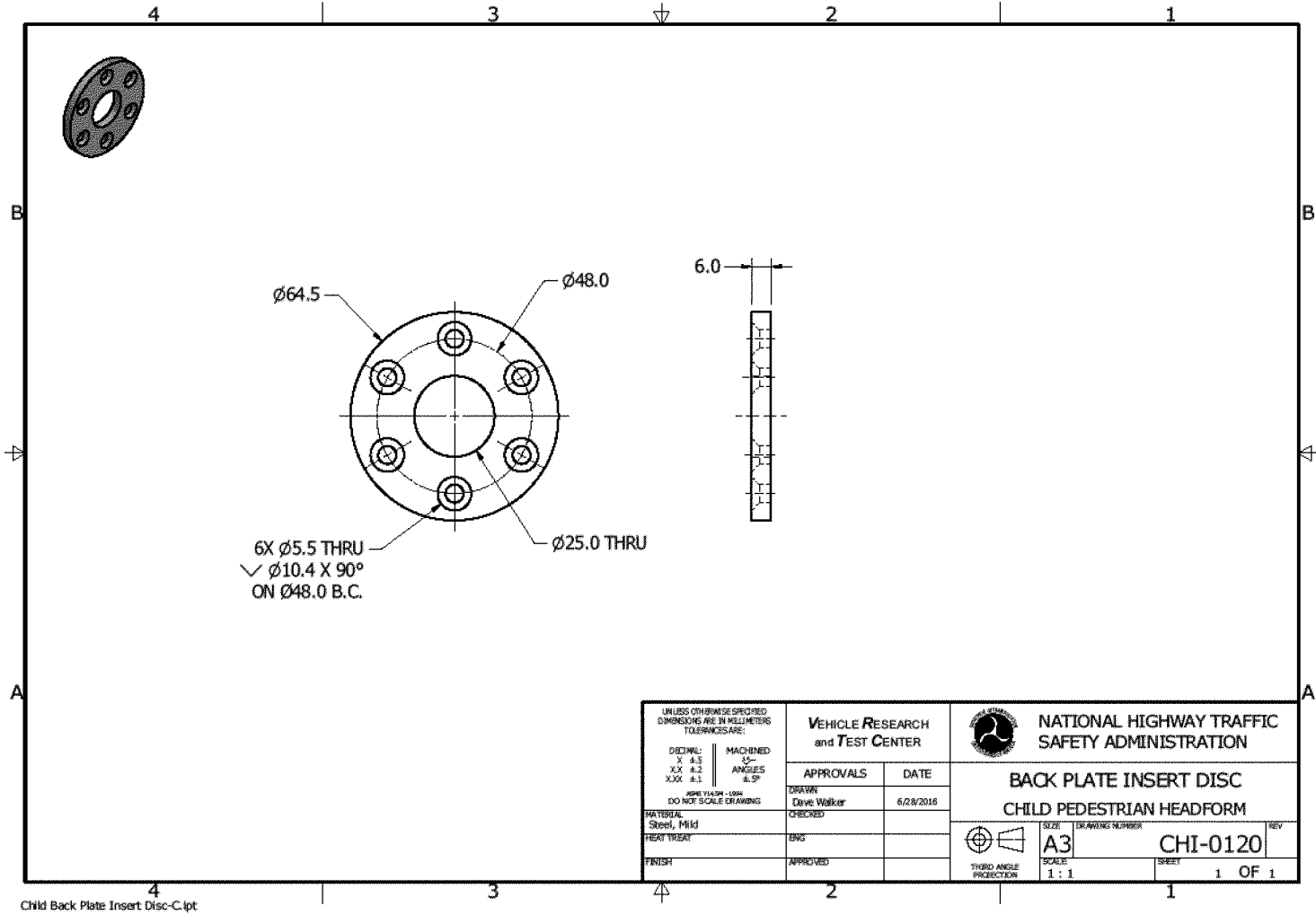

Figure 17 - Child Headform Drawing 5



<small>UNLESS OTHERWISE SPECIFIED DIMENSIONS ARE IN MILLIMETERS TOLERANCES ARE:</small> DECIMAL: X .1 MACHINED S- XX .2 ANGLES 4.5° XXX .1 <small>ASME Y14.5M - 1994 DO NOT SCALE DRAWINGS</small>	<b>VEHICLE RESEARCH and TEST CENTER</b>		 NATIONAL HIGHWAY TRAFFIC SAFETY ADMINISTRATION	
	APPROVALS	DATE		
	MATERIAL: Steel, Mild	DRAWN: Dave Walker	5/28/2016	BACK PLATE INSERT DISC CHILD PEDESTRIAN HEADFORM
	FINISH	APPROVED		
			SIZE: A3 SCALE: 1:1 DRAWING NUMBER: CHI-0120 SHEET: 1 OF 1	

Figure 18 - Child Headform Drawing 6



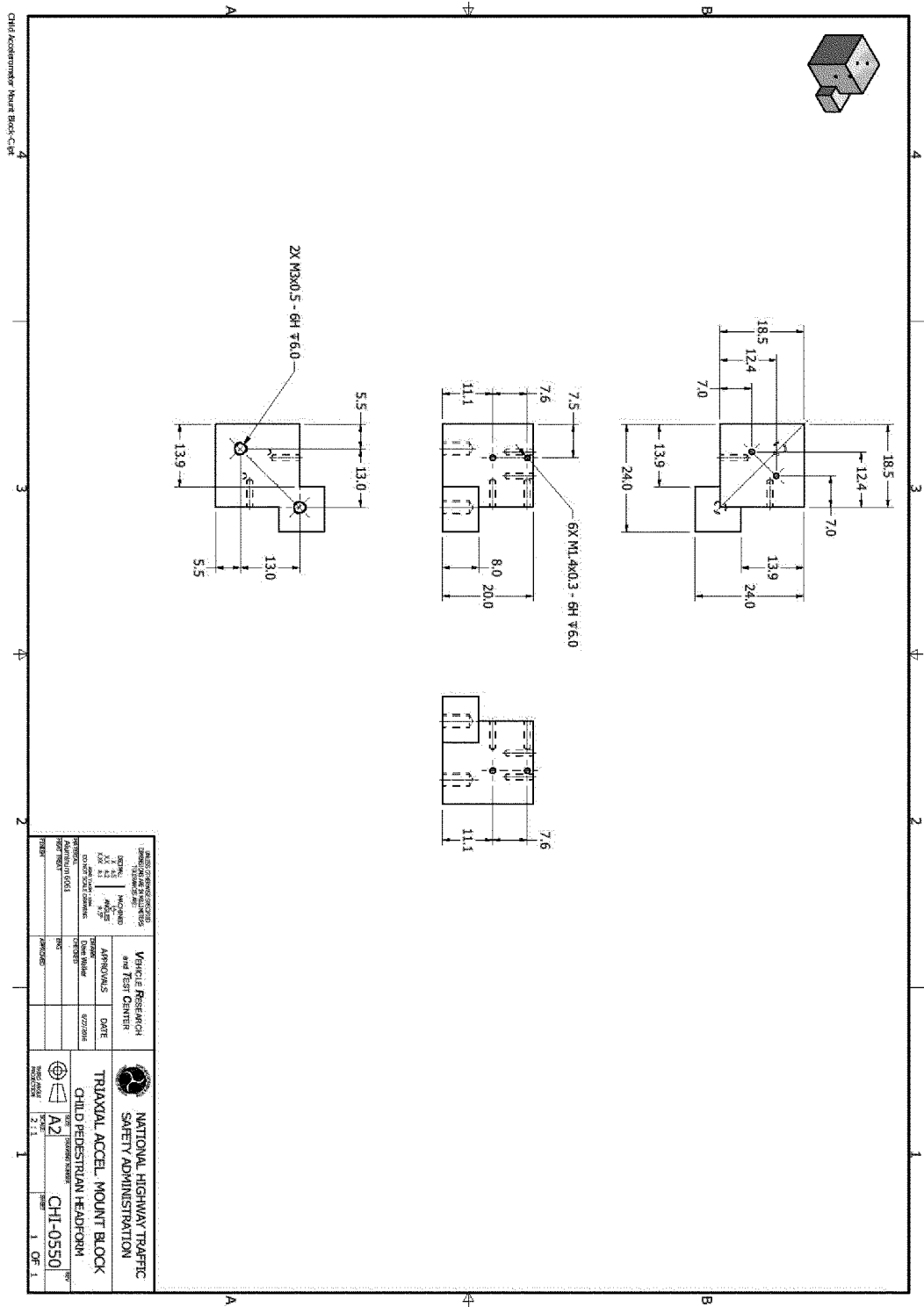
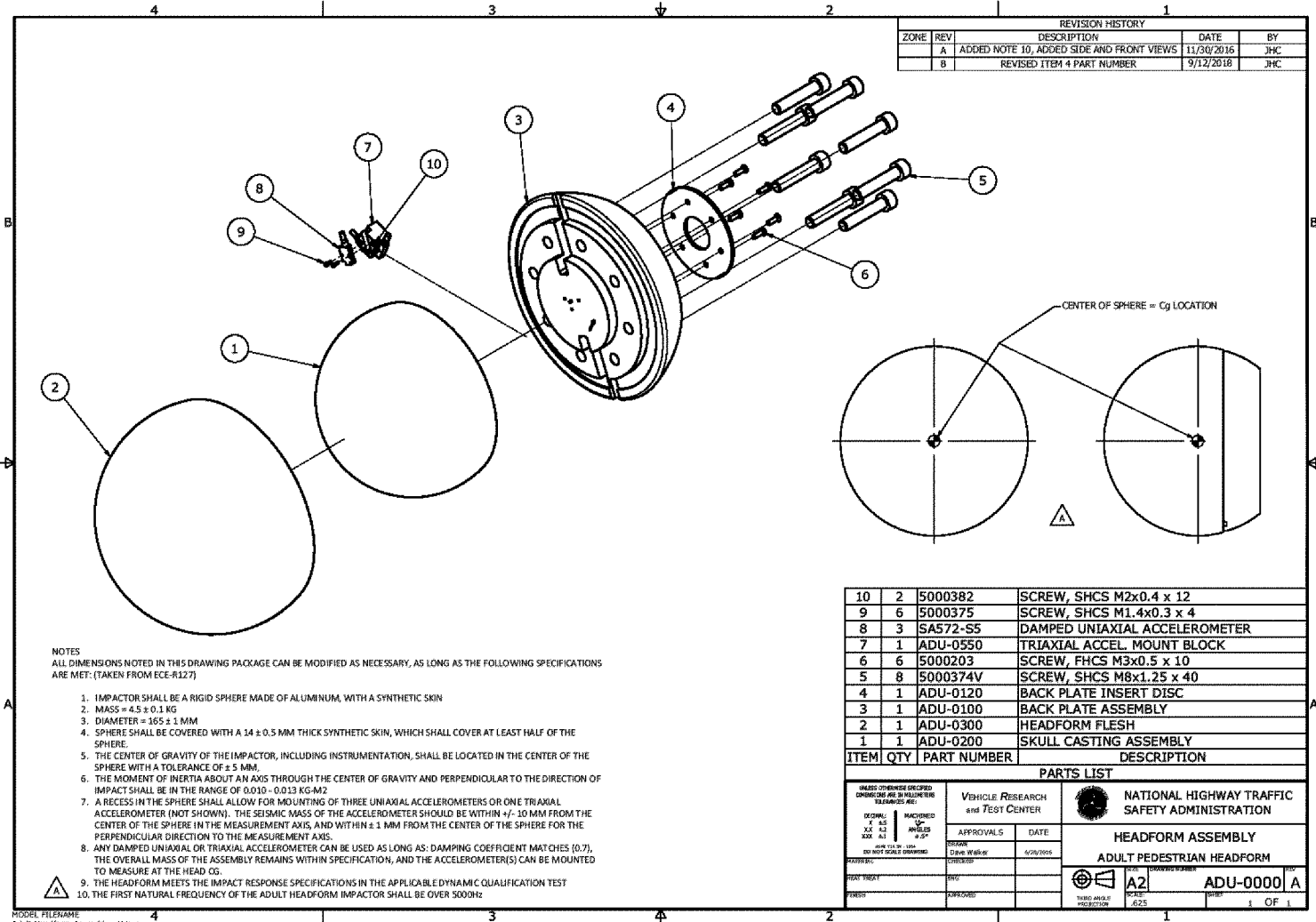

Figure 19 - Child Headform Drawing 7



REVISION HISTORY				
ZONE	REV	DESCRIPTION	DATE	BY
A		ADDED NOTE 10, ADDED SIDE AND FRONT VIEWS	11/30/2016	JHC
B		REVISED ITEM 4 PART NUMBER	9/12/2018	JHC

NOTES  
 ALL DIMENSIONS NOTED IN THIS DRAWING PACKAGE CAN BE MODIFIED AS NECESSARY, AS LONG AS THE FOLLOWING SPECIFICATIONS ARE MET: (TAKEN FROM ECE-R127)

- IMPACTOR SHALL BE A RIGID SPHERE MADE OF ALUMINUM, WITH A SYNTHETIC SKIN
- MASS =  $4.5 \pm 0.1$  KG
- DIAMETER =  $165 \pm 1$  MM
- SPHERE SHALL BE COVERED WITH A  $14 \pm 0.5$  MM THICK SYNTHETIC SKIN, WHICH SHALL COVER AT LEAST HALF OF THE SPHERE.
- THE CENTER OF GRAVITY OF THE IMPACTOR, INCLUDING INSTRUMENTATION, SHALL BE LOCATED IN THE CENTER OF THE SPHERE WITH A TOLERANCE OF  $\pm 5$  MM.
- THE MOMENT OF INERTIA ABOUT AN AXIS THROUGH THE CENTER OF GRAVITY AND PERPENDICULAR TO THE DIRECTION OF IMPACT SHALL BE IN THE RANGE OF 0.010 - 0.013 KG-M<sup>2</sup>
- A RECESS IN THE SPHERE SHALL ALLOW FOR MOUNTING OF THREE UNIAXIAL ACCELEROMETERS OR ONE TRIAXIAL ACCELEROMETER (NOT SHOWN). THE SEISMIC MASS OF THE ACCELEROMETER SHOULD BE WITHIN  $\pm 10$  MM FROM THE CENTER OF THE SPHERE IN THE MEASUREMENT AXIS, AND WITHIN  $\pm 1$  MM FROM THE CENTER OF THE SPHERE FOR THE PERPENDICULAR DIRECTION TO THE MEASUREMENT AXIS.
- ANY DAMPED UNIAXIAL OR TRIAXIAL ACCELEROMETER CAN BE USED AS LONG AS DAMPING COEFFICIENT MATCHES (0.7). THE OVERALL MASS OF THE ASSEMBLY REMAINS WITHIN SPECIFICATION, AND THE ACCELEROMETER(S) CAN BE MOUNTED TO MEASURE AT THE HEAD CG.
- THE HEADFORM MEETS THE IMPACT RESPONSE SPECIFICATIONS IN THE APPLICABLE DYNAMIC QUALIFICATION TEST
- THE FIRST NATURAL FREQUENCY OF THE ADULT HEADFORM IMPACTOR SHALL BE OVER 5000Hz

ITEM	QTY	PART NUMBER	DESCRIPTION
10	2	5000382	SCREW, SHCS M2x0.4 x 12
9	6	5000375	SCREW, SHCS M1.4x0.3 x 4
8	3	SA572-S5	DAMPED UNIAXIAL ACCELEROMETER
7	1	ADU-0550	TRIAxIAL ACCEL. MOUNT BLOCK
6	6	5000203	SCREW, FHCS M3x0.5 x 10
5	8	5000374V	SCREW, SHCS M8x1.25 x 40
4	1	ADU-0120	BACK PLATE INSERT DISC
3	1	ADU-0100	BACK PLATE ASSEMBLY
2	1	ADU-0300	HEADFORM FLESH
1	1	ADU-0200	SKULL CASTING ASSEMBLY

PARTS LIST		VEHICLE RESEARCH and TEST CENTER		NATIONAL HIGHWAY TRAFFIC SAFETY ADMINISTRATION	
UNLESS OTHERWISE SPECIFIED DIMENSIONS ARE IN MILLIMETERS TO NEAREST 0.01	DECIMALS	APPROVALS	DATE	HEADFORM ASSEMBLY	
1.00	1	DESIGN	DATE	ADULT PEDESTRIAN HEADFORM	
0.50	2	TEST	DATE	ADU-0000	
0.25	3	APPROVED	DATE	SCALE	1 OF 1
0.10	4	DATE	DATE	4:25	

Figure 20 - Adult Headform Assembly Drawing 1

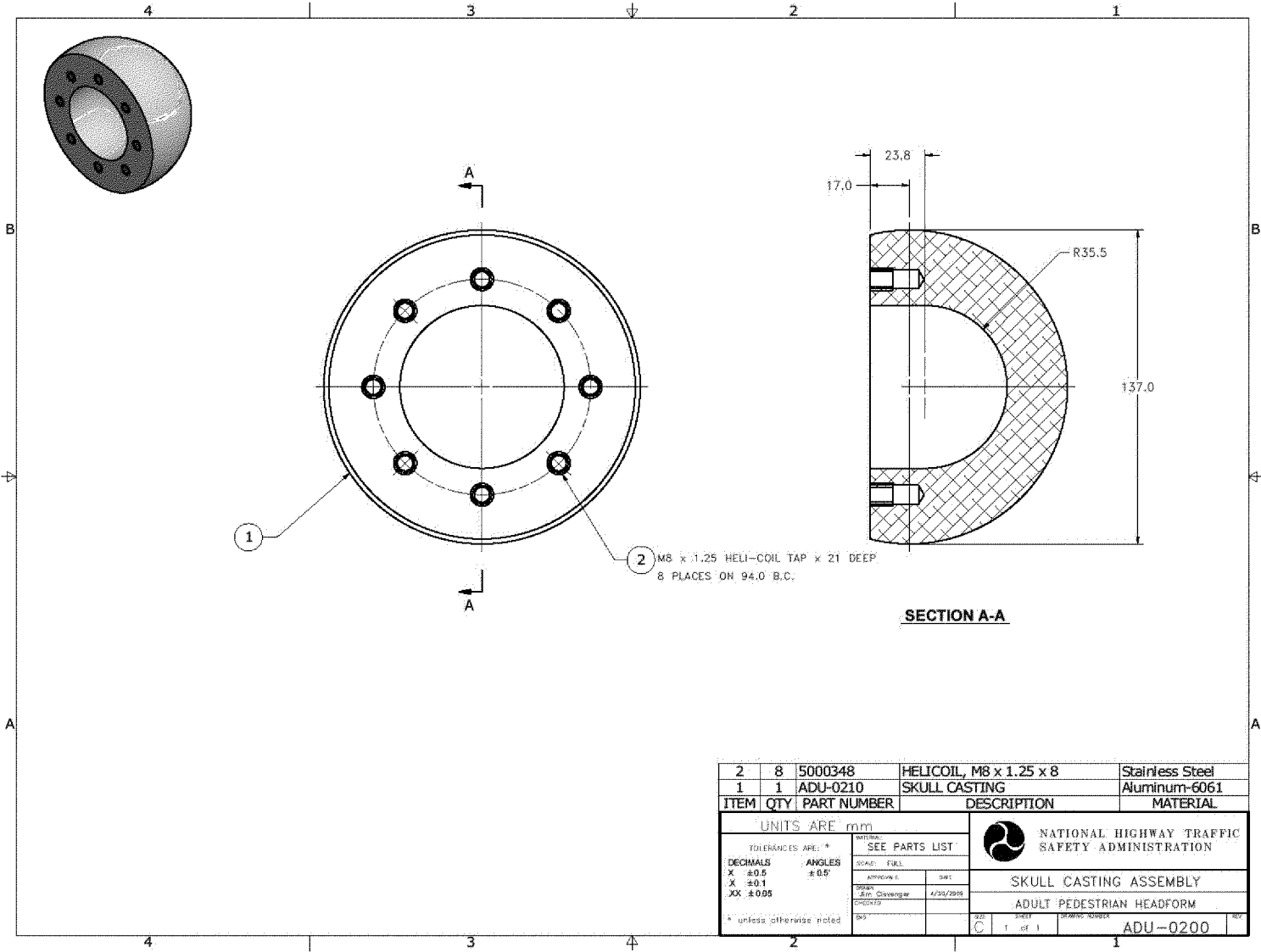

Figure 21 – Adult Headform Drawing 2

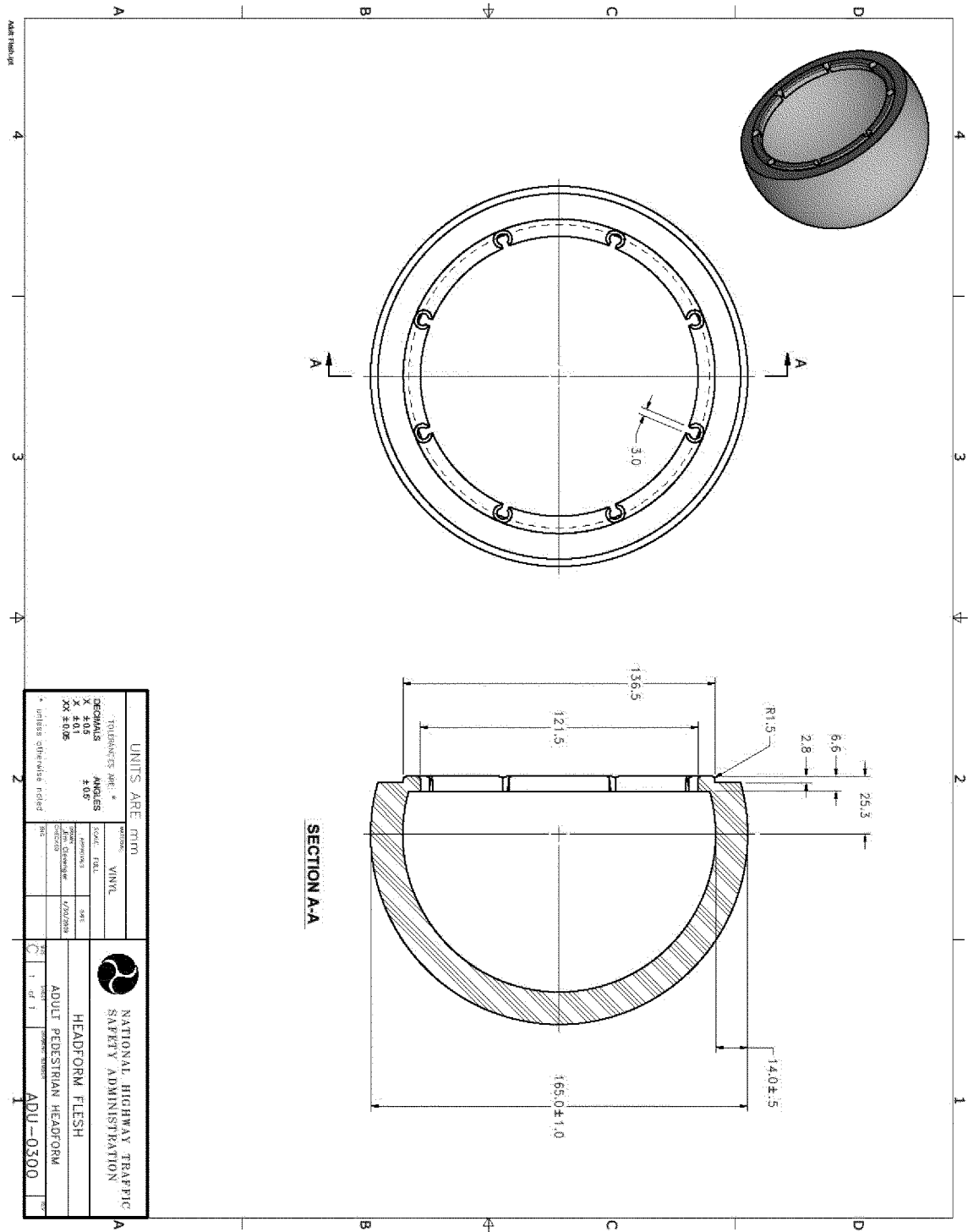

Figure 22 - Adult Headform Drawing 3

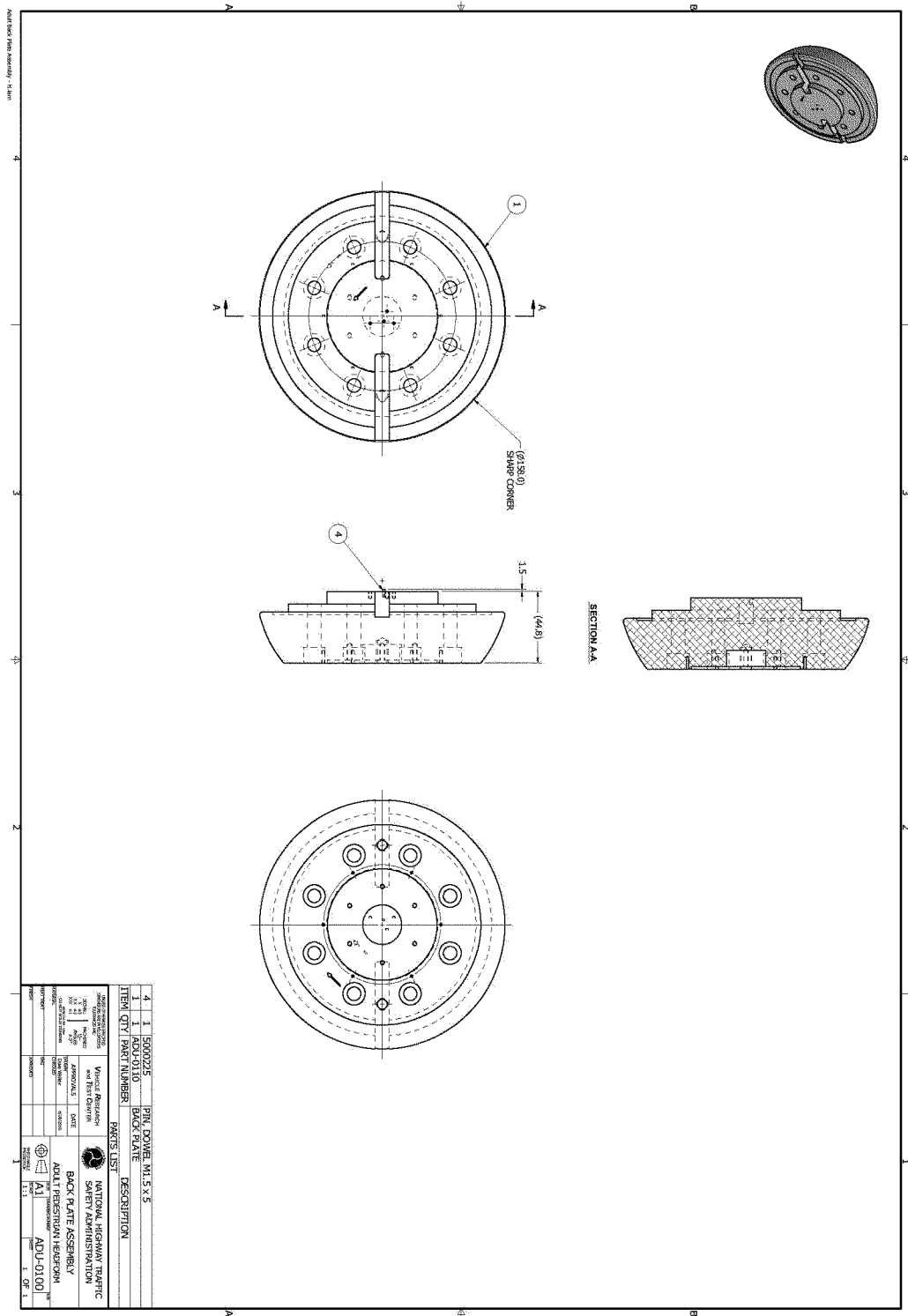

Figure 23 - Adult Headform Drawing 4

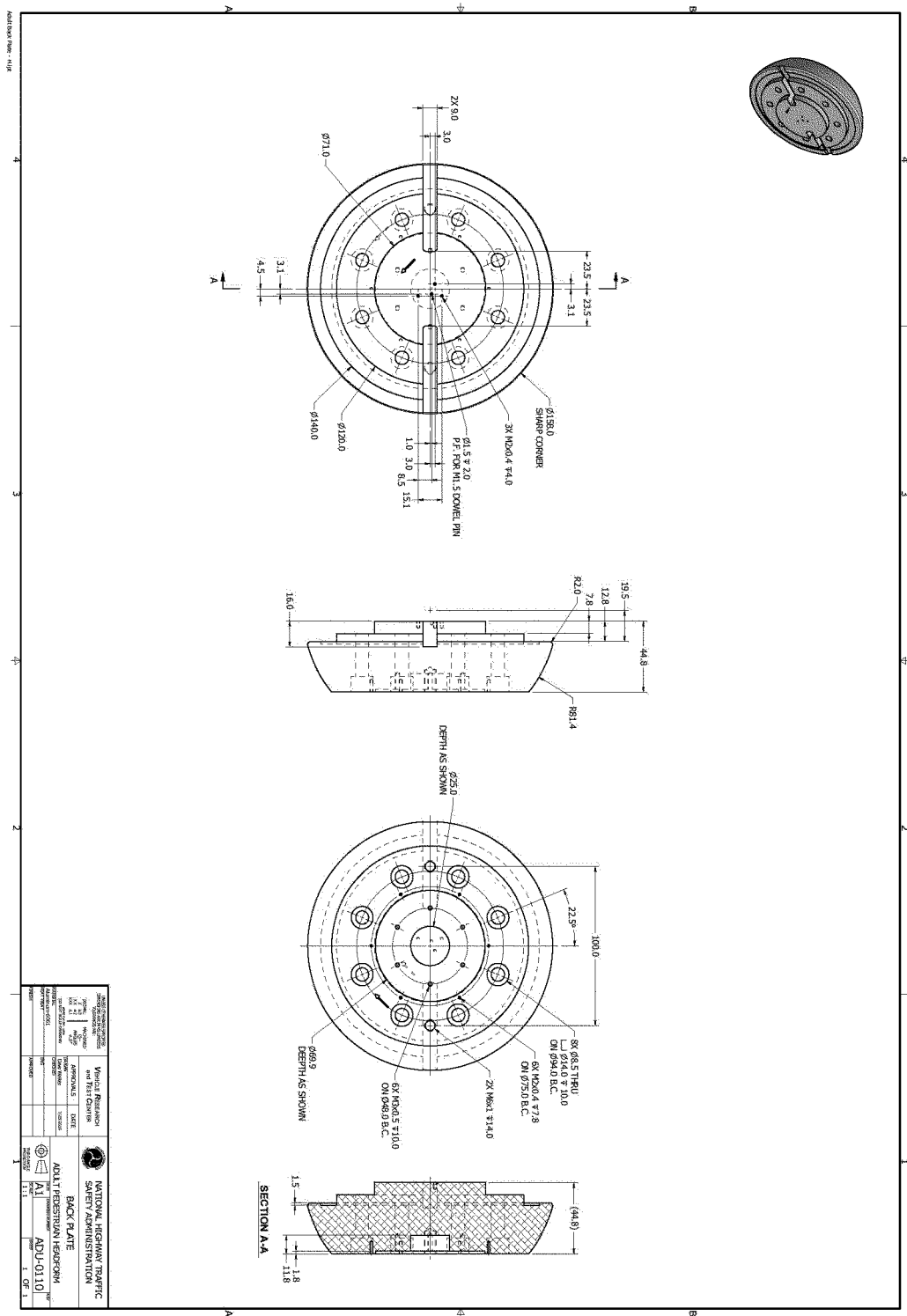

Figure 24 - Adult Headform Drawing 5

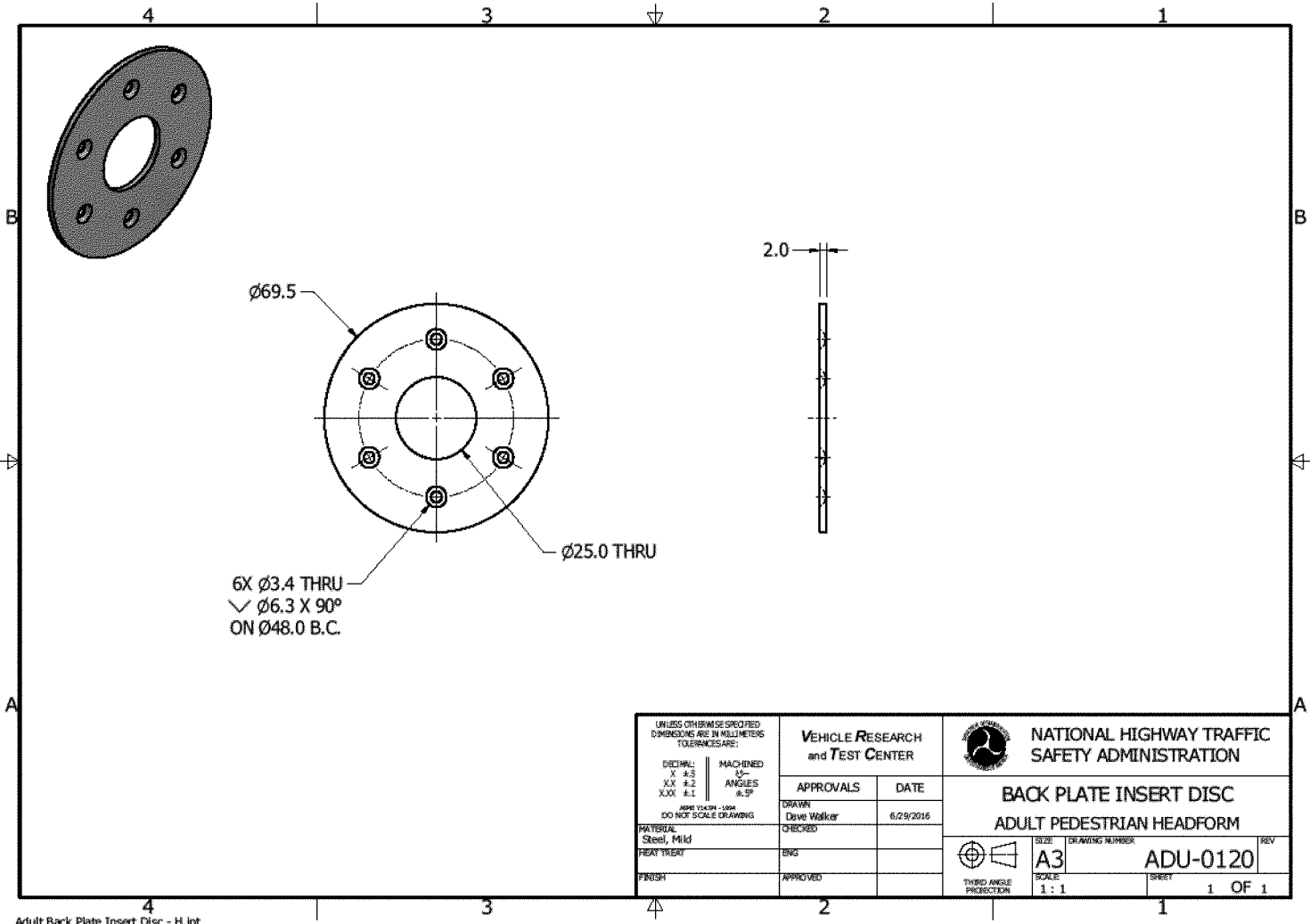

Figure 25 - Adult Headform Drawing 6

Adult Back Plate Insert Disc - H.lpt

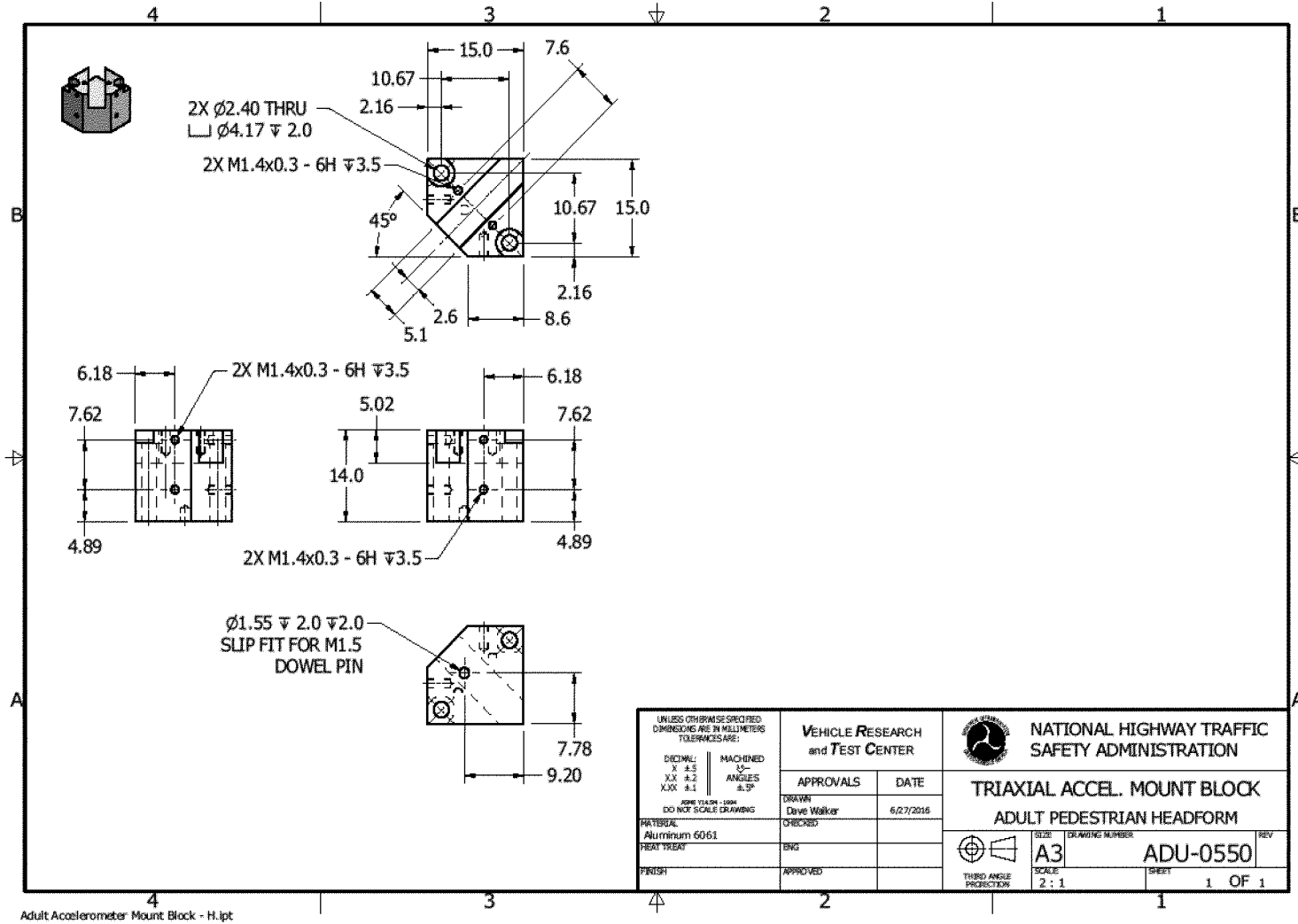

Figure 26 Adult Headform Drawing 7



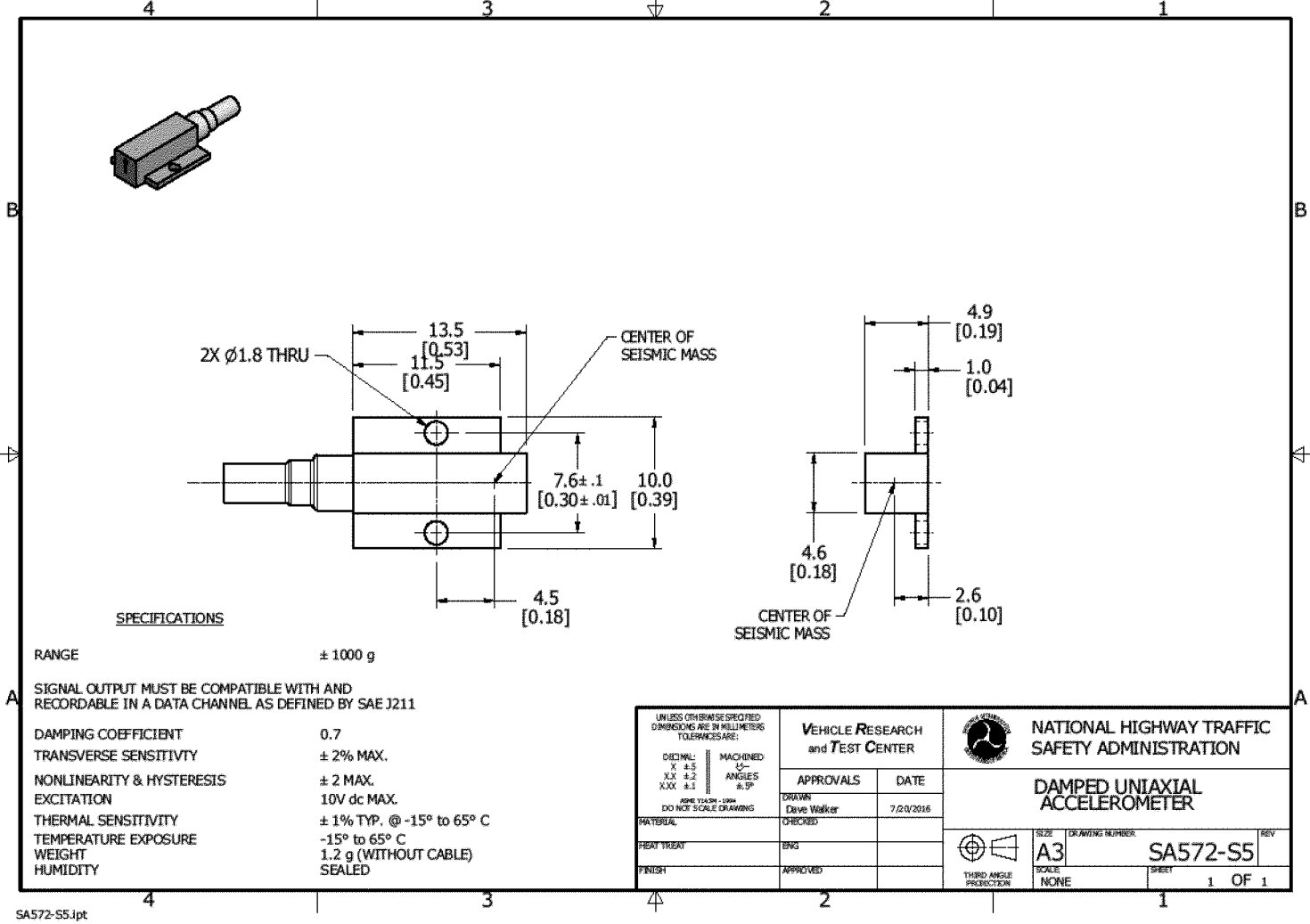

Figure 27. Uniaxial Accelerometer

Issued in Washington, DC, under authority delegated in 49 CFR 1.95 and 501.5.

**Sophie Shulman,**  
Deputy Administrator.

[FR Doc. 2024-20653 Filed 9-18-24; 8:45 am]

BILLING CODE 4910-59-C