

Proposed Rules

Federal Register

Vol. 89, No. 153

Thursday, August 8, 2024

This section of the FEDERAL REGISTER contains notices to the public of the proposed issuance of rules and regulations. The purpose of these notices is to give interested persons an opportunity to participate in the rule making prior to the adoption of the final rules.

DEPARTMENT OF TRANSPORTATION

Federal Aviation Administration

14 CFR Part 39

[Docket No. FAA-2024-2011; Project Identifier AD-2023-01121-R]

RIN 2120-AA64

Airworthiness Directives; MD Helicopters, LLC, Helicopters

AGENCY: Federal Aviation Administration (FAA), DOT.

ACTION: Notice of proposed rulemaking (NPRM).

SUMMARY: The FAA proposes to adopt a new airworthiness directive (AD) for certain MD Helicopters, LLC (MDHI), Model 369, 369A, 369D, 369E, 369F, 369FF, 369H, 369HE, 369HM, 369HS, 500N, and 600N helicopters. This proposed AD was prompted by a report of a seized and damaged roller bearing in the pilot interconnecting cyclic torque tube (torque tube) assembly. This proposed AD would require repetitively inspecting the torque tube assembly for corrosion and cracks and the roller bearings for corrosion and degradation. This proposed AD would also require repetitively inspecting the torque tube assembly for freedom-of-movement. Depending on the results, this proposed AD would require replacing parts or accomplishing additional inspections. The FAA is proposing this AD to address the unsafe condition on these products.

DATES: The FAA must receive comments on this proposed AD by September 23, 2024.

ADDRESSES: You may send comments, using the procedures found in 14 CFR 11.43 and 11.45, by any of the following methods:

- *Federal eRulemaking Portal:* Go to *regulations.gov*. Follow the instructions for submitting comments.
- *Fax:* (202) 493-2251.
- *Mail:* U.S. Department of Transportation, Docket Operations, M-

30, West Building Ground Floor, Room W12-140, 1200 New Jersey Avenue SE, Washington, DC 20590.

• *Hand Delivery:* Deliver to Mail address above between 9 a.m. and 5 p.m., Monday through Friday, except Federal holidays.

AD Docket: You may examine the AD docket at *regulations.gov* under Docket No. FAA-2024-2011; or in person at Docket Operations between 9 a.m. and 5 p.m., Monday through Friday, except Federal holidays. The AD docket contains this NPRM, any comments received, and other information. The street address for Docket Operations is listed above.

FOR FURTHER INFORMATION CONTACT:

Eduardo Orozco-Duran, Aviation Safety Engineer, FAA, 3960 Paramount Boulevard, Lakewood, CA 90712; phone: (562) 627-5264; email: eduardo.orozco-duran@faa.gov.

SUPPLEMENTARY INFORMATION:

Comments Invited

The FAA invites you to send any written relevant data, views, or arguments about this proposal. Send your comments to an address listed under **ADDRESSES**. Include "Docket No. FAA-2024-2011; Project Identifier AD-2023-01121-R" at the beginning of your comments. The most helpful comments reference a specific portion of the proposal, explain the reason for any recommended change, and include supporting data. The FAA will consider all comments received by the closing date and may amend this proposal because of those comments.

Except for Confidential Business Information (CBI) as described in the following paragraph, and other information as described in 14 CFR 11.35, the FAA will post all comments received, without change, to *regulations.gov*, including any personal information you provide. The agency will also post a report summarizing each substantive verbal contact received about this NPRM.

Confidential Business Information

CBI is commercial or financial information that is both customarily and actually treated as private by its owner. Under the Freedom of Information Act (FOIA) (5 U.S.C. 552), CBI is exempt from public disclosure. If your comments responsive to this NPRM contain commercial or financial

information that is customarily treated as private, that you actually treat as private, and that is relevant or responsive to this NPRM, it is important that you clearly designate the submitted comments as CBI. Please mark each page of your submission containing CBI as "PROPIN." The FAA will treat such marked submissions as confidential under the FOIA, and they will not be placed in the public docket of this NPRM. Submissions containing CBI should be sent to Eduardo Orozco-Duran, Aviation Safety Engineer, FAA, 3960 Paramount Boulevard, Lakewood, CA 90712; phone: (562) 627-5264; email: eduardo.orozco-duran@faa.gov. Any commentary that the FAA receives which is not specifically designated as CBI will be placed in the public docket for this rulemaking.

Background

The FAA received a report of a seized and damaged roller bearing assembly in the torque tube assembly of an MDHI Model MD369E helicopter. This damage did not allow the torque tube to rotate as designed, which initiated a crack and resulted in an emergency landing. The seized roller bearings were due to rust compounded with dried grease residue and an aggressive chemical environment. Because the seized roller bearings did not allow the torque tube to rotate freely, additional torsional stresses occurred on the torque tube, causing a crack to initiate and eventually propagate until the part failed and longitudinal control was lost. Since MDHI Model 369, 369A, 369D, 369F, 369FF, 369H, 369HE, 369HM, 369HS, 500N, and 600N helicopters have the same torque tube assembly installed, they are also affected by this unsafe condition.

Accordingly, this proposed AD would require repetitively visually inspecting the torque tube for corrosion and cracks, repetitively visually inspecting the roller bearings for corrosion and degradation, performing a repetitive freedom-of-movement inspection of the torque tube assembly for binding or ratcheting, and corrective or additional action as necessary. This condition, if not addressed, could result in reduced controllability and subsequent loss of control of the helicopter.

FAA's Determination

The FAA is issuing this NPRM after determining that the unsafe condition

described previously is likely to exist or develop on other products of the same type design.

Proposed AD Requirements in This NPRM

This proposed AD would require repetitive visual inspections of the torque tube assembly for cracks and corrosion and the roller bearings for corrosion and degradation. This proposed AD would also require repetitively inspecting the freedom of movement of the torque tube assembly for binding and ratcheting. Depending on the results, this proposed AD would require replacing parts or accomplishing additional inspections.

Costs of Compliance

The FAA estimates that this AD, if adopted as proposed, would affect 353 helicopters of U.S. registry. The FAA estimates the following costs to comply with this proposed AD. Labor costs are estimated at \$85 per work-hour.

Visually inspecting the torque tube and roller bearings would take approximately 1 work-hour for an estimated cost of \$85 per helicopter and \$30,005 for the U.S. fleet, per inspection cycle. Inspecting the torque tube assembly for freedom of movement would take approximately 0.75 work-hour for an estimated cost of \$64 per helicopter and \$22,595 for U.S. fleet cost, per inspection cycle. If required, a more in-depth inspection of the roller bearings would take approximately 0.25 work-hour for an estimated cost of \$21 per helicopter, per instance.

If required, replacing a torque tube would take approximately 6 work-hours and parts would cost approximately \$4,773 for an estimated cost of \$5,283 per torque tube replacement. Replacing a roller bearing would take approximately 6 work-hours and parts would cost approximately \$210 for an estimated cost of \$720 per roller bearing replacement.

Authority for This Rulemaking

Title 49 of the United States Code specifies the FAA's authority to issue rules on aviation safety. Subtitle I, section 106, describes the authority of the FAA Administrator. Subtitle VII: Aviation Programs, describes in more

detail the scope of the Agency's authority.

The FAA is issuing this rulemaking under the authority described in Subtitle VII, Part A, Subpart III, Section 44701: General requirements. Under that section, Congress charges the FAA with promoting safe flight of civil aircraft in air commerce by prescribing regulations for practices, methods, and procedures the Administrator finds necessary for safety in air commerce. This regulation is within the scope of that authority because it addresses an unsafe condition that is likely to exist or develop on products identified in this rulemaking action.

Regulatory Findings

The FAA determined that this proposed AD would not have federalism implications under Executive Order 13132. This proposed AD would not have a substantial direct effect on the States, on the relationship between the national government and the States, or on the distribution of power and responsibilities among the various levels of government.

For the reasons discussed above, I certify this proposed regulation:

- (1) Is not a "significant regulatory action" under Executive Order 12866,
- (2) Would not affect intrastate aviation in Alaska, and
- (3) Would not have a significant economic impact, positive or negative, on a substantial number of small entities under the criteria of the Regulatory Flexibility Act.

List of Subjects in 14 CFR Part 39

Air transportation, Aircraft, Aviation safety, Incorporation by reference, Safety.

The Proposed Amendment

Accordingly, under the authority delegated to me by the Administrator, the FAA proposes to amend 14 CFR part 39 as follows:

PART 39—AIRWORTHINESS DIRECTIVES

- 1. The authority citation for part 39 continues to read as follows:

Authority: 49 U.S.C. 106(g), 40113, 44701.

§ 39.13 [Amended]

- 2. The FAA amends § 39.13 by adding the following new airworthiness directive:

MD Helicopters, LLC: Docket No. FAA–2024–2011; Project Identifier AD–2023–01121–R.

(a) Comments Due Date

The FAA must receive comments on this airworthiness directive (AD) by September 23, 2024.

(b) Affected ADs

None.

(c) Applicability

This AD applies to MD Helicopters, LLC, Model 369, 369A, 369D, 369E, 369F, 369FF, 369H, 369HE, 369HM, 369HS, 500N, and 600N helicopters, certificated in any category, with a pilot interconnecting cyclic torque tube (torque tube) part number 369H7133–7 installed.

(d) Subject

Joint Aircraft System Component (JASC) Code 6700, Rotorcraft Flight Control.

(e) Unsafe Condition

This AD was prompted by a report of a seized and damaged roller bearing in the torque tube assembly. The FAA is issuing this AD to prevent failure of the torque tube assembly. The unsafe condition, if not addressed, could result in reduced controllability and subsequent loss of control of the helicopter.

(f) Compliance

Comply with this AD within the compliance times specified, unless already done.

(g) Required Actions

(1) Within 100 hours time-in-service (TIS) or within one year after the effective date of this AD, whichever occurs first, and thereafter at intervals not to exceed 100 hours TIS, accomplish the actions required by paragraphs (g)(1)(i) and (ii) of this AD.

(i) Using a flashlight and mirror, visually inspect the torque tube for corrosion and cracks. If there is any corrosion or a crack, before further flight, remove the torque tube from service and install an airworthy torque tube.

(ii) Visually inspect each roller bearing (number 5) as depicted in Figure 1 to paragraph (g)(1) of this AD for corrosion and degradation. If a roller bearing has any corrosion or degradation, before further flight, remove the roller bearing from service and install an airworthy roller bearing.

BILLING CODE 4910–13–P

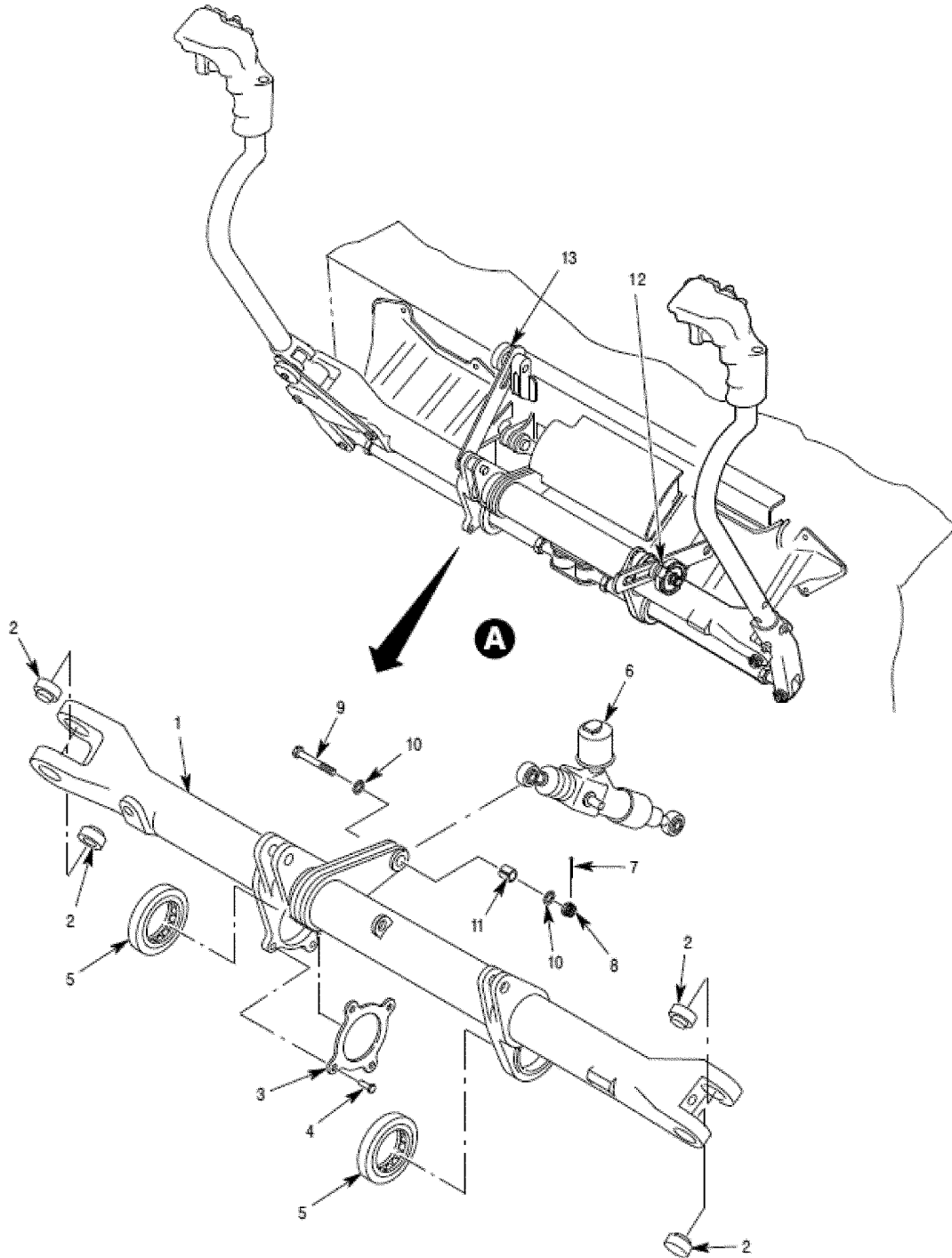
**BILLING CODE 4910-13-C**

(2) Before the helicopter accumulates 3,000 total hours TIS or within 100 hours TIS after the effective date of this AD, whichever occurs later, and thereafter at intervals not to exceed 100 hours TIS, perform a freedom-of movement inspection on the torque tube assembly by accomplishing the actions required by paragraphs (g)(2)(i) through (v) of this AD.

(i) Disconnect the one-way lock (number 6) of the torque tube by removing the cotter pin (number 7), nut (number 8), bolt (number 9), washers (number 10), and slotted bushing

(number 11) from the torque tube assembly as depicted in Figure 1 to paragraph (g)(1) of this AD.

(ii) Loosen the longitudinal cyclic friction knob (number 12 or 13) of the torque tube assembly as depicted in Figure 1 to paragraph (g)(1) of this AD.

(iii) While moving the cyclic control forward and aft to allow the torque tube assembly to rotate through its full range of motion, inspect the torque tube assembly for binding and ratcheting.

(A) If there is any binding or ratcheting as a result of the action required by paragraph

(g)(2)(iii) of this AD, before further flight, inspect each roller bearing (number 5) as depicted in Figure 1 to paragraph (g)(1) of this AD for damage. For the purposes of this inspection, damage may be indicated by corrosion, lack of lubrication (dry exterior surface), or material degradation.

(B) If any roller bearing (number 5) as depicted in Figure 1 to paragraph (g)(1) of this AD has any damage, before further flight, remove the roller bearing from service and install an airworthy roller bearing.

(iv) If there is not any binding or ratcheting as a result of the action required by

paragraph (g)(2)(iii) of this AD or after accomplishing the action required by paragraph (g)(2)(iii)(B) of this AD, as applicable, tighten the cyclic friction knob (number 12 or 13) as depicted in Figure 1 to paragraph (g)(1) of this AD.

(v) Connect the one-way lock (number 6) as depicted in Figure 1 to paragraph (g)(1) of this AD by accomplishing the actions required by paragraphs (g)(2)(v)(A) and (B).

(A) Install the slotted bushing (number 11), washers (number 10), bolt (number 9), nut (number 8), and new (zero total hours TIS) cotter pin (number 7) as depicted in Figure 1 to paragraph (g)(1) of this AD.

(B) Ensure the edge of the slotted bushing (number 11) protrudes 0.010 to 0.080 inch (0.25 to 2.03 mm) above the surface of the cyclic torque tube after the nut is tightened.

(h) Alternative Methods of Compliance (AMOCs)

(1) The Manager, West Certification Branch, FAA, has the authority to approve AMOCs for this AD, if requested using the procedures found in 14 CFR 39.19. In accordance with 14 CFR 39.19, send your request to your principal inspector or responsible Flight Standards Office, as appropriate. If sending information directly to the manager of the West Certification Branch, send it to the attention of the person identified in paragraph (i) of this AD. Information may be emailed to: AMOC@faa.gov.

(2) Before using any approved AMOC, notify your appropriate principal inspector, or lacking a principal inspector, the manager of the local flight standards district office/certificate holding district office.

(i) Additional Information

For more information about this AD, contact Eduardo Orozco-Duran, Aviation Safety Engineer, FAA, 3960 Paramount Boulevard, Lakewood, CA 90712; phone: (562) 627-5264; email: eduardo.orozco-duran@faa.gov.

(j) Material Incorporated by Reference

None.

Issued on July 31, 2024.

Victor Wicklund,

Deputy Director, Compliance & Airworthiness Division, Aircraft Certification Service.

[FR Doc. 2024-17339 Filed 8-7-24; 8:45 am]

BILLING CODE 4910-13-P

DEPARTMENT OF TRANSPORTATION

Federal Aviation Administration

14 CFR Part 39

[Docket No. FAA-2024-2012; Project Identifier MCAI-2023-01208-T]

RIN 2120-AA64

Airworthiness Directives; MHI RJ Aviation ULC (Type Certificate Previously Held by Bombardier, Inc.) Airplanes

AGENCY: Federal Aviation Administration (FAA), DOT.

ACTION: Notice of proposed rulemaking (NPRM).

SUMMARY: The FAA proposes to adopt a new airworthiness directive (AD) for all MHI RJ Aviation ULC Model CL-600-2B19 (Regional Jet Series 100 & 440) airplanes. This proposed AD was prompted by the discovery of ten ultrasonic inspections associated with airworthiness limitations (AWL) tasks and structural deviation inspection requirements (SDIR) tasks potentially not detecting cracks. This proposed AD would require repetitive ultrasonic inspections of certain structural areas for cracking as specified in a Transport Canada AD, which is proposed for incorporation by reference (IBR), and repair of cracking, as applicable. This proposed AD would also prohibit use of the previous revisions of certain procedures and mandate the use of the revised procedures when performing the inspections required by the associated AWL and SDIR tasks. The FAA is proposing this AD to address the unsafe condition on these products.

DATES: The FAA must receive comments on this proposed AD by September 23, 2024.

ADDRESSES: You may send comments, using the procedures found in 14 CFR 11.43 and 11.45, by any of the following methods:

- *Federal eRulemaking Portal:* Go to [regulations.gov](https://www.regulations.gov). Follow the instructions for submitting comments.

- *Fax:* 202-493-2251.

- *Mail:* U.S. Department of Transportation, Docket Operations, M-30, West Building Ground Floor, Room W12-140, 1200 New Jersey Avenue SE, Washington, DC 20590.

- *Hand Delivery:* Deliver to Mail address above between 9 a.m. and 5 p.m., Monday through Friday, except Federal holidays.

AD Docket: You may examine the AD docket at [regulations.gov](https://www.regulations.gov) under Docket No. FAA-2024-2012; or in person at Docket Operations between 9 a.m. and

5 p.m., Monday through Friday, except Federal holidays. The AD docket contains this NPRM, the mandatory continuing airworthiness information (MCAI), any comments received, and other information. The street address for Docket Operations is listed above.

Material Incorporated by Reference:

- For Transport Canada material in this proposed AD, contact Transport Canada, Transport Canada National Aircraft Certification, 159 Cleopatra Drive, Nepean, Ontario K1A 0N5, Canada; telephone 888-663-3639; email TC.AirworthinessDirectives-Consignesdenavigabilite.TC@tc.gc.ca. You may find this material on the Transport Canada website at tc.canada.ca/en/aviation. It is also available at [regulations.gov](https://www.regulations.gov) under Docket No. FAA-2024-2012.

- You may view this material at the FAA, Airworthiness Products Section, Operational Safety Branch, 2200 South 216th St., Des Moines, WA. For information on the availability of this material at the FAA, call 206-231-3195.

FOR FURTHER INFORMATION CONTACT: Yaser Osman, Aviation Safety Engineer, FAA, 1600 Stewart Avenue, Suite 410, Westbury, NY 11590; telephone (516) 228-7300; email: 9-avs-nyaco-cos@faa.gov.

SUPPLEMENTARY INFORMATION:

Comments Invited

The FAA invites you to send any written relevant data, views, or arguments about this proposal. Send your comments to an address listed under the **ADDRESSES** section. Include “Docket No. FAA-2024-2012; Project Identifier MCAI-2023-01208-T” at the beginning of your comments. The most helpful comments reference a specific portion of the proposal, explain the reason for any recommended change, and include supporting data. The FAA will consider all comments received by the closing date and may amend this proposal because of those comments.

Except for Confidential Business Information (CBI) as described in the following paragraph, and other information as described in 14 CFR 11.35, the FAA will post all comments received, without change, to [regulations.gov](https://www.regulations.gov), including any personal information you provide. The agency will also post a report summarizing each substantive verbal contact received about this NPRM.

Confidential Business Information

CBI is commercial or financial information that is both customarily and actually treated as private by its owner. Under the Freedom of Information Act