

DEPARTMENT OF ENERGY**10 CFR Parts 429, 430, and 431**

[EERE-2019-BT-TP-0032]

RIN 1904-AE77

Energy Conservation Program: Test Procedure for Consumer Water Heaters and Residential-Duty Commercial Water Heaters

AGENCY: Office of Energy Efficiency and Renewable Energy, Department of Energy.

ACTION: Final rule.

SUMMARY: This final rule incorporates by reference the latest version of the industry testing standard for consumer water heaters and residential-duty commercial water heaters and adopts relevant portions of those standards into the Federal test procedure. In this final rule, the U.S. Department of Energy (DOE) is also expanding the scope of coverage of the test procedure to apply to certain consumer water heater designs (including circulating water heaters and low-temperature water heaters), adding definitions for certain specialty water heaters, updating test conditions and tolerance requirements to reduce burden, clarifying test set-up and installation methods, addressing the test conduct for products which can store water at temperatures above the delivery setpoint, establishing an effective volume calculation, and extending untested provisions to electric instantaneous water heaters.

DATES: The effective date of this rule is July 21, 2023. The final rule changes will be mandatory for consumer water heater testing starting December 18, 2023 and for residential-duty commercial water heater testing starting June 17, 2024. The incorporation by reference of certain material listed in this rule is approved by the Director of the Federal Register on July 21, 2023.

ADDRESSES: The docket, which includes **Federal Register** notices, public meeting attendee lists and transcripts, comments, and other supporting documents/materials, is available for review at www.regulations.gov. All documents in the docket are listed in the www.regulations.gov index. However, not all documents listed in the index may be publicly available, such as those containing information that is exempt from public disclosure.

A link to the docket web page can be found at: www.regulations.gov/docket/EERE-2019-BT-TP-0032. The docket web page contains instructions on how to access all documents, including public comments, in the docket.

For further information on how to review the docket, contact the Appliance and Equipment Standards Program staff at (202) 287-1445 or by email: ApplianceStandardsQuestions@ee.doe.gov.

FOR FURTHER INFORMATION CONTACT:

Ms. Julia Hegarty, U.S. Department of Energy, Office of Energy Efficiency and Renewable Energy, Building Technologies Office, EE-5B, 1000 Independence Avenue SW, Washington, DC 20585-0121. Telephone: (202) 597-6737. Email: ApplianceStandardsQuestions@ee.doe.gov.

Mr. Eric Stas, U.S. Department of Energy, Office of the General Counsel, GC-33, 1000 Independence Avenue SW, Washington, DC 20585-0121. Telephone: (202) 586-5827. Email: Eric.Stas@hq.doe.gov.

SUPPLEMENTARY INFORMATION: DOE incorporates by reference the following industry standards into part 430:

ANSI/ASHRAE Standard 41.1-2020, “Standard Methods for Temperature Measurement,” ANSI-approved June 30, 2020 (“ASHRAE 41.1-2020”).

ANSI/ASHRAE Standard 41.6-2014, “Standard Method for Humidity Measurement,” ANSI-approved July 3, 2014 (“ASHRAE 41.6-2014”).

ANSI/ASHRAE Standard 118.2-2022, “Method of Testing for Rating Residential Water Heaters and Residential-Duty Commercial Water Heaters,” ANSI-approved March 1, 2022 (“ASHRAE 118.2-2022”).

Copies of ASHRAE 41.1-2020, ASHRAE 41.6-2014, and ASHRAE 118.2-2022 can be obtained from the American Society of Heating, Refrigerating, and Air-Conditioning Engineers, Inc., (ASHRAE), 180 Technology Parkway NW, Peachtree Corners, GA 30092, (800) 527-4723 or (404) 636-8400, or online at: www.ashrae.org.

ASTM D2156-09 (Reapproved 2018) “Standard Test Method for Smoke Density in Flue Gases from Burning Distillate Fuels,” approved October 1, 2018 (“ASTM D2156-09 (RA 2018)”).

ASTM E97-82 (Reapproved 1987) “Standard Test Methods for Directional Reflectance Factor, 45-Deg 0-Deg, of Opaque Specimens by Broad-Band Filter Reflectometry,” approved October 29, 1982 and withdrawn 1991 (“ASTM E97-1987 (W1991)”).

Copies of ASTM D2156-09 (RA 2018) can be obtained from ASTM International (ASTM), 100 Barr Harbor Drive, P.O. Box C700, West Conshohocken, PA 19428-2959 or online at: www.astm.org.

Copies of ASTM E97-1987 (W1991) are reasonably available from standards

resellers including GlobalSpec’s Engineering 360 (<https://standards.globalspec.com/std/3801495/astm-e97-82-1987>) and IHS Markit (https://global.ihs.com/doc_detail.cfm?document_name=ASTM%20E97&item_s_key=00020483).

See section IV.N of this document for a further discussion of these industry standards.

Table of Contents

- I. Authority and Background
 - A. Authority
 - B. Background
- II. Synopsis of the Final Rule
- III. Discussion
 - A. Scope of Applicability and Definitions
 - 1. Demand-Response Water Heaters
 - 2. Heat Pump Water Heaters
 - 3. Residential-Duty Commercial Water Heaters
 - 4. Specialty Water Heaters
 - B. Updates to Industry Standards
 - 1. ASHRAE 41.1-2020
 - 2. ASHRAE 118.2-2022
 - C. Test Conditions and Tolerances
 - 1. Supply Water Temperature Measurements
 - 2. Gas Pressure
 - 3. Input Rate
 - 4. Ambient Test Condition Tolerances
 - 5. Electrical Supply Voltage Tolerances
 - 6. Flow Rate Tolerances
 - 7. Optional Test Conditions for Heat Pump Water Heaters
 - D. Test Set-Up and Installation
 - 1. Split-System Heat Pump Water Heaters
 - 2. Mixing Valves
 - 3. Flow Meter Location
 - 4. Separate Storage Tanks
 - E. Test Conduct
 - 1. High Temperature Testing
 - 2. Very Small Draw Pattern Flow Rate
 - 3. Low-Temperature Water Heaters
 - 4. Delivery Temperature for Flow-Activated Water Heaters
 - 5. Heat Pump Water Heaters
 - 6. Draw Pattern for Commercial Applications
 - 7. Method for Determining Internal Tank Temperature for Certain Water Heaters
 - 8. Alternate Order 24-Hour Simulated-Use Test
 - F. Computations
 - 1. Mass Calculations
 - 2. Effective Storage Volume
 - G. Untested Provisions (Alternative Efficiency Determination Methods)
 - 1. Representations of First-Hour Ratings for Untested Basic Models
 - 2. Alternative Rating Method for Electric Instantaneous Water Heaters
 - H. Corrections and Clarifications
 - 1. Flow-Activated Terminology
 - 2. Second Identical 24-Hour Simulated-Use Test
 - 3. Connected Products
 - 4. Heating Value of Gas
 - I. Effective and Compliance Dates
 - J. Test Procedure Costs
 - 1. Separate Storage Tanks
 - 2. Method for Determining Internal Tank Temperature for Certain Water Heaters

3. High Temperature Testing
 4. Additional Amendments
- IV. Procedural Issues and Regulatory Review
- A. Review Under Executive Orders 12866, 13563, and 14094
 - B. Review Under the Regulatory Flexibility Act
 - C. Review Under the Paperwork Reduction Act of 1995
 - D. Review Under the National Environmental Policy Act of 1969
 - E. Review Under Executive Order 13132
 - F. Review Under Executive Order 12988
 - G. Review Under the Unfunded Mandates Reform Act of 1995
 - H. Review Under the Treasury and General Government Appropriations Act, 1999
 - I. Review Under Executive Order 12630
 - J. Review Under Treasury and General Government Appropriations Act, 2001
 - K. Review Under Executive Order 13211
 - L. Review Under Section 32 of the Federal Energy Administration Act of 1974
 - M. Congressional Notification
 - N. Description of Materials Incorporated by Reference
- V. Approval of the Office of the Secretary

I. Authority and Background

Consumer water heaters are included in the list of “covered products” for which DOE is authorized to establish and amend energy conservation standards and test procedures. (42 U.S.C. 6292(a)(4)) DOE’s energy conservation standards and test procedures for consumer water heaters are currently prescribed respectively at title 10 of the Code of Federal Regulations (CFR), part 430, section 32(d), and 10 CFR part 430, subpart B, appendix E ((appendix E), *Uniform Test Method for Measuring the Energy Consumption of Water Heaters*. Residential-duty commercial water heaters, for which DOE is also authorized to establish and amend energy conservation standards and test procedures (42 U.S.C. 6311(1)(K)), must also be tested according to appendix E. 10 CFR 431.106(b)(1) (*See* 42 U.S.C. 6295(e)(5)(H)). DOE’s energy conservation standards for residential-duty commercial water heaters are currently prescribed at 10 CFR 431.110(b)(1). The following sections discuss DOE’s authority to establish and amend test procedures for consumer water heaters and residential-duty commercial water heaters, as well as relevant background information regarding DOE’s consideration of test procedures for these products and equipment.

A. Authority

The Energy Policy and Conservation Act, as amended (EPCA),¹ authorizes

¹ All references to EPCA in this document refer to the statute as amended through the Energy Act of 2020, Public Law 116–260 (Dec. 27, 2020), which

DOE to regulate the energy efficiency of a number of consumer products and certain industrial equipment. (42 U.S.C. 6291–6317, as codified) Title III, Part B² of EPCA established the Energy Conservation Program for Consumer Products Other Than Automobiles, which sets forth a variety of provisions designed to improve energy efficiency. (42 U.S.C. 6291–6309, as codified) These products include consumer water heaters, one of the subjects of this document. (42 U.S.C. 6292(a)(4)) Title III, Part C³ of EPCA, added by Public Law 95–619, Title IV, section 441(a), established the Energy Conservation Program for Certain Industrial Equipment, which again sets forth a variety of provisions designed to improve energy efficiency. (42 U.S.C. 6311–6317, as codified) This equipment includes residential-duty commercial water heaters, which are also the subject of this document. (42 U.S.C. 6311(1)(K))

The energy conservation program under EPCA consists essentially of four parts: (1) testing, (2) labeling, (3) Federal energy conservation standards, and (4) certification and enforcement procedures. Relevant provisions of EPCA specifically include definitions (42 U.S.C. 6291; 42 U.S.C. 6311), test procedures (42 U.S.C. 6293; 42 U.S.C. 6314), labeling provisions (42 U.S.C. 6294; 42 U.S.C. 6315), energy conservation standards (42 U.S.C. 6295; 42 U.S.C. 6313), and the authority to require information and reports from manufacturers (42 U.S.C. 6296; 42 U.S.C. 6316).

The Federal testing requirements consist of test procedures that manufacturers of covered products and commercial equipment must use as the basis for: (1) certifying to DOE that their products/equipment comply with the applicable energy conservation standards adopted pursuant to EPCA (42 U.S.C. 6295(s); 42 U.S.C. 6296; 42 U.S.C. 6316(a)-(b)), and (2) making other representations about the efficiency of those products/equipment (42 U.S.C. 6293(c); 42 U.S.C. 6314(d)). Similarly, DOE must use these test procedures to determine whether the products comply with any relevant standards promulgated under EPCA. (42 U.S.C. 6295(s))

Federal energy efficiency requirements for covered products and equipment established under EPCA generally supersede State laws and regulations concerning energy

reflect the last statutory amendments that impact Parts A and A–1 of EPCA.

² For editorial reasons, upon codification in the U.S. Code, Part B was redesignated Part A.

³ For editorial reasons, upon codification in the U.S. Code, Part C was redesignated Part A–1.

conservation testing, labeling, and standards. (42 U.S.C. 6297(a)-(c); 42 U.S.C. 6316(a)-(b)) DOE may, however, grant waivers of Federal preemption in limited circumstances for particular State laws or regulations, in accordance with the procedures and other provisions of EPCA. (42 U.S.C. 6297(d); 42 U.S.C. 6316(a); 42 U.S.C. 6316(b)(2)(D))

Under 42 U.S.C. 6293, EPCA sets forth the criteria and procedures DOE must follow when prescribing or amending test procedures for covered products. Specifically, EPCA requires that any test procedures prescribed or amended shall be reasonably designed to produce test results which measure energy efficiency, energy use, or estimated annual operating cost of a covered product during a representative average use cycle or period of use and not be unduly burdensome to conduct. (42 U.S.C. 6293(b)(3)) Under 42 U.S.C. 6314, the statute sets forth the criteria and procedures DOE must follow when prescribing or amending test procedures for covered equipment, reciting similar requirements at 42 U.S.C. 6314(a)(2).

In addition, the Energy Independence and Security Act of 2007 amended EPCA to require that DOE amend its test procedures for all covered consumer products to integrate measures of standby mode and off mode energy consumption. (42 U.S.C. 6295(gg)(2)(A)) Standby mode and off mode energy consumption must be incorporated into the overall energy efficiency, energy consumption, or other energy descriptor for each covered product, unless the current test procedure already accounts for and incorporates the standby mode and off mode energy consumption, or if such integration is technically infeasible. (42 U.S.C. 6295(gg)(2)(A)(i)–(ii)) If an integrated test procedure is technically infeasible, DOE must prescribe separate standby mode and off mode energy use test procedures for the covered product, if a separate test is technically feasible. (42 U.S.C. 6295(gg)(2)(A)(ii)) Any such amendment must consider the most current versions of the International Electrotechnical Commission (IEC) Standard 62301⁴ and IEC Standard 62087,⁵ as applicable. (42 U.S.C. 6295(gg)(2)(A))

The American Energy Manufacturing Technical Corrections Act (AEMTCA), Public Law 112–210, further amended

⁴ IEC 62301, *Household electrical appliances—Measurement of standby power* (Edition 2.0, 2011–01).

⁵ IEC 62087, *Audio, video and related equipment—Methods of measurement for power consumption* (Edition 1.0, Parts 1–6: 2015, Part 7: 2018).

EPCA to require that DOE establish a uniform efficiency descriptor and accompanying test methods to replace the energy factor (EF) metric for covered consumer water heaters and the thermal efficiency (TE) and standby loss (SL) metrics for commercial water-heating equipment⁶ within one year of the enactment of AEMTCA. (42 U.S.C. 6295(e)(5)(B)–(C)) The uniform efficiency descriptor and accompanying test method were required to apply, to the maximum extent practicable, to all water-heating technologies in use at the time and to future water-heating technologies, but could exclude specific categories of covered water heaters that do not have residential uses, can be clearly described, and are effectively rated using the TE and SL descriptors. (42 U.S.C. 6295(e)(5)(F) and (H)) In addition, beginning one year after the date of publication of DOE’s final rule establishing the uniform descriptor, the efficiency standards for covered water heaters were required to be denominated according to the uniform efficiency descriptor established in the final rule (42 U.S.C. 6295(e)(5)(D)); and for affected covered water heaters tested prior to the effective date of the test procedure final rule, DOE was required to develop a mathematical factor for converting the measurement of their energy efficiency from the EF, TE, and SL metrics to the new uniform energy descriptor. (42 U.S.C. 6295(e)(5)(E)(i)–(ii))

EPCA also requires that, at least once every seven years, DOE evaluate test procedures for each type of covered product and covered equipment, including consumer water heaters and residential-duty commercial water heaters, to determine whether amended test procedures would more accurately or fully comply with the requirements for the test procedures to not be unduly burdensome to conduct and be

⁶ The initial thermal efficiency and standby loss test procedures for commercial water heating equipment (including residential-duty commercial water heaters) were added to EPCA by the Energy Policy Act of 1992 (EPACT 1992), Public Law 102–486, and corresponded to those referenced in the ASHRAE and Illuminating Engineering Society of North America (IESNA) Standard 90.1–1989 (*i.e.*, ASHRAE Standard 90.1–1989). (42 U.S.C. 6314(a)(4)(A)) DOE subsequently updated the commercial water heating equipment test procedures on two separate occasions—once in a direct final rule published on October 21, 2004, and again in a final rule published on May 16, 2012. These rules incorporated by reference certain sections of the latest versions of American National Standards Institute (ANSI) Standard Z21.10.3, *Gas Water Heaters, Volume III, Storage Water Heaters with Input Ratings Above 75,000 Btu Per Hour, Circulating and Instantaneous*, available at the time (*i.e.*, ANSI Z21.10.3–1998 and ANSI Z21.10.3–2011, respectively). 69 FR 61974, 61983 (Oct. 21, 2004) and 77 FR 28928, 28996 (May 16, 2012).

reasonably designed to produce test results that reflect energy efficiency, energy use, and estimated operating costs during a representative average use cycle (or additionally, period of use for consumer products). (42 U.S.C. 6293(b)(1)(A); 42 U.S.C. 6314(a)(1)(A))

If the Secretary determines, on her own behalf or in response to a petition by any interested person, that a test procedure should be prescribed or amended, the Secretary shall promptly publish in the **Federal Register** proposed test procedures and afford interested persons an opportunity to present oral and written data, views, and arguments with respect to such procedures. (42 U.S.C. 6293(b)(2); 42 U.S.C. 6314(b)) The comment period on a proposed rule to amend a test procedure shall be at least 60 days⁷ and may not exceed 270 days. (42 U.S.C. 6293(b)(2)) In prescribing or amending a test procedure, the Secretary shall take into account such information as the Secretary determines relevant to such procedure, including technological developments relating to energy use or energy efficiency of the type (or class) of covered products involved. (42 U.S.C. 6293(b)(2)) If DOE determines that test procedure revisions are not appropriate, DOE must publish in the **Federal Register** its determination not to amend the test procedures. (42 U.S.C. 6293(b)(1)(A)(ii); 42 U.S.C. 6314(a)(1)(A)(ii)) DOE is publishing this final rule in satisfaction of the 7-year review requirement specified in EPCA. (42 U.S.C. 6293(b)(1)(A) and 42 U.S.C. 6314(a)(1)(A))

B. Background

The following discussion provides a brief history of the current rulemaking, which considers potential amendments to the test procedure for consumer water heaters and residential-duty commercial water heaters.⁸ On April 16, 2020, DOE published in the **Federal Register** a request for information (April 2020 RFI) seeking comments on the existing DOE test procedure for consumer water heaters and residential-duty commercial water heaters. 85 FR 21104. The April 2020 RFI discussed a draft version of the

⁷ For covered equipment, if the Secretary determines that a test procedure amendment is warranted, the Secretary must publish proposed test procedures in the **Federal Register** and afford interested persons an opportunity (of not less than 45 days’ duration) to present oral and written data, views, and arguments on the proposed test procedure. (42 U.S.C. 6314(b))

⁸ For a more complete history of earlier rulemaking efforts to develop the energy conservation standards and test procedure for consumer water heaters and residential-duty commercial water heaters, please consult the January 11, 2022 NOPR. See 87 FR 1554, 1556–1558.

American National Standards Institute (ANSI)/American Society of Heating, Refrigeration, and Air Conditioning Engineers (ASHRAE) Standard 118.2, “Method of Testing for Rating Residential Water Heaters and Residential-Duty Commercial Water Heaters,” published in March 2019 (March 2019 ASHRAE Draft 118.2), which is very similar to the existing DOE test procedure for consumer water heaters and residential-duty commercial water heaters. 85 FR 21104, 21108–21110 (April 16, 2020).

In the April 2020 RFI, DOE requested comments, information, and data about a number of issues, including: (1) differences between the March 2019 ASHRAE Draft 118.2 and the existing DOE test procedure; (2) test tolerances for supply water temperature, ambient temperature, relative humidity, voltage, and gas pressure; (3) the location of the instrumentation that measures water volume or mass; and (4) how to test certain types of consumer water heaters that cannot be easily tested to the existing DOE test procedure (*i.e.*, recirculating gas-fired instantaneous water heaters, water heaters that cannot deliver water at 125 degrees Fahrenheit (°F) ±5 °F, and water heaters with storage volumes greater than 2 gallons that cannot have their internal tank temperatures measured). *Id.* at 85 FR 21109–21114.

DOE subsequently published in the **Federal Register** a notice of proposed rulemaking on January 11, 2022 (January 2022 NOPR) in which the Department proposed to update appendix E, and related sections of the CFR, as follows:

(1) Incorporate by reference current versions of industry standards referenced by the current and proposed DOE test procedures: ASHRAE Standard 41.1,⁹ ASHRAE Standard 41.6,¹⁰ the pending update to ASHRAE Standard 118.2¹¹ (contingent on it being substantively the same as the draft which was under review), ASTM International (ASTM) Standard D2156,¹² and ASTM Standard E97.¹³

⁹ ASHRAE Standard 41.1–2020, “Standard Methods for Temperature Measurement,” approved June 30, 2020.

¹⁰ ASHRAE Standard 41.6–2014, “Standard Method for Humidity Measurement,” ANSI approved July 3, 2014.

¹¹ ASHRAE Standard 118.2–2022, “Method of Testing for Rating Residential Water Heaters and Residential-Duty Commercial Water Heaters,” ANSI approved March 1, 2022.

¹² ASTM Standard D2156–09 (RA 2018), “Standard Test Method for Smoke Density in Flue Gases from Burning Distillate Fuels,” reapproved October 1, 2018.

¹³ ASTM Standard E97–1987 (W 1991), “Standard Test Methods for Directional Reflectance Factor, 45-

(2) Add definitions for “circulating water heater,” “low temperature water heater,” and “tabletop water heater.”

(3) Specify how a mixing valve should be installed when the water heater is designed to operate with one.

(4) Modify flow rate requirements during the first-hour rating (FHR) test for water heaters with a rated storage volume less than 20 gallons.

(5) Modify timing of the first measurement in each draw of the 24-hour simulated-use test.

(6) Clarify the determination of the first recovery period.

(7) Clarify the mass of water to be used to calculate recovery efficiency.

(8) Modify the terminology throughout appendix E to explicitly state “non-flow activated” and “flow-activated” water heater, where appropriate.

(9) Clarify the descriptions of defined measured values for the standby period measurements.

(10) Modify the test condition specifications and tolerances, including electric supply voltage tolerance, ambient temperature, ambient dry-bulb temperature, ambient relative humidity, standard temperature and pressure definition, gas supply pressure, and manifold pressure.

(11) Add provisions to address gas-fired water heaters with measured fuel input rates that deviate from the certified input rate.

(12) Clarify provisions for calculating the volume or mass delivered.

(13) Add specifications for testing for the newly defined “low temperature water heaters.”

(14) Clarify testing requirements for the heat pump part of a split-system heat pump water heater.

(15) Define the use of a separate unfired hot water storage tank for testing water heaters designed to operate with a separately sold hot water storage tank.

(16) Clarify that any connection to an external network or control be disconnected during testing.

(17) Add procedures for estimating internal stored water temperature for water heater designs in which the internal tank temperature cannot be directly measured.

(18) Modify the provisions for untested water heater basic models within 10 CFR 429.70(g) to include electric instantaneous water heaters. 87 FR 1554, 1558.¹⁴

DOE held a public meeting related to the January 2022 NOPR on January 27, 2022 (hereinafter, the NOPR public meeting).

On July 14, 2022, DOE published a supplemental notice of proposed rulemaking in the **Federal Register** (July 2022 SNOPR), that proposed to maintain the proposals from the January 2022 NOPR but with modifications discussed in the July 2022 SNOPR. 87 FR 42270. Specifically, the July 2022 SNOPR proposed to further update appendix E and related sections of the CFR by:

(1) Additionally requiring that, for water heaters with rated storage volume less than 2 gallons and a rated maximum gallons per minute (Max GPM or maximum GPM) of less than 1 gallon per minute, the flow rate tolerance shall be ±25 percent of the rated Max GPM.

(2) Allowing optional efficiency representations at alternative test conditions for heat pump water heaters.

(3) Adding a definition for “split-system heat pump water heaters” to distinguish these from circulating heat pump water heaters (*i.e.*, “heat pump-only” water heaters).

(4) Requiring gas-fired circulating water heaters to be tested using an unfired hot water storage tank (UFHWST) with a storage volume between 80 and 120 gallons and meets but does not exceed the minimum energy conservation standards (based on

R-value) required at 10 CFR 431.110(a), and that circulating heat pump water heaters be tested using a 40-gallon electric resistance water heater at the minimum UEF standard required at 10 CFR 430.32(d).

(5) Requiring that water heaters (with the exception of demand-response water heaters) with user-selectable modes to “overheat” the water stored in the tank to increase effective capacity be tested at the highest internal tank temperature that can be achieved while maintaining the outlet water temperature at 125 °F ±5 °F. (If no such overheated mode exists, the unit is to be tested in a default mode.)

(6) Defining “demand-response water heater” based on the U.S. Environmental Protection Agency (EPA) ENERGY STAR Product Specification for Residential Water Heaters Version 5.0 (ENERGY STAR Water Heaters Specification v5.0)¹⁵ definition for “connected water heating product,” with the additional requirement that demand-response water heaters cannot overheat as a result of user-initiated operation.

(7) Establishing a metric and method for determining the effective storage volume.

(8) Adopting a method of determining the internal storage tank temperature for certain water heaters which cannot be directly measured using draws at the beginning and end of the 24-hour simulated-use test. 87 FR 42270, 42273–42274 (July 14, 2022).

This final rule responds to comments received in response to the January 2022 NOPR that were not addressed in the July 2022 SNOPR and comments received in response to the July 2022 SNOPR. Table I.1 presents the list of commenters who provided written submissions and/or oral statements at the NOPR public meeting which are addressed in this final rule.

TABLE I.1—LIST OF COMMENTERS WITH WRITTEN SUBMISSIONS ADDRESSED IN THIS FINAL RULE

Commenter(s)	Reference in this final rule	Comment No. in the docket	Commenter type
A.O. Smith Corporation	A.O. Smith	NOPR No. 37; Transcript*; SNOPR No. 51*.	Manufacturer.
Air Conditioning, Heating, and Refrigeration Institute	AHRI	NOPR No. 40; Transcript; SNOPR No. 55.	Manufacturer Trade Association.
American Public Gas Association	APGA	NOPR No. 38	Utility Trade Association.
Appliance Standards Awareness Project	ASAP	Transcript	Efficiency Advocacy Organization.
Appliance Standards Awareness Project, American Council for an Energy-Efficient Economy, National Consumer Law Center (on behalf of its low-income clients).	ASAP, ACEEE, and NCLC	NOPR No. 34	Efficiency Advocacy Organizations.

Deg 0-Deg. of Opaque Specimens by Broad-Band Filter Reflectometry,” approved January 1987, withdrawn 1991. Referenced by ASTM Standard D2156–09 (RA 2018).

¹⁴ A correction was published in the **Federal Register** on January 19, 2022, to properly reflect the

date of the public meeting to discuss the January 2022 NOPR. 87 FR 2731.

¹⁵ EPA published the ENERGY STAR Water Heater Specification v5.0 on July 18, 2022. The ENERGY STAR Water Heater Specification v5.0 is available online at: www.energystar.gov/products/spec/residential_water_heaters_specification_version_5_0_pd (Last accessed on July 25, 2022).

TABLE I.1—LIST OF COMMENTERS WITH WRITTEN SUBMISSIONS ADDRESSED IN THIS FINAL RULE—Continued

Commenter(s)	Reference in this final rule	Comment No. in the docket	Commenter type
Appliance Standards Awareness Project, American Council for an Energy-Efficient Economy, Natural Resources Defense Council.	ASAP, ACEEE, and NRDC	SNOPR No. 54	Efficiency Advocacy Organizations.
Applied Energy Technology Company	AET	NOPR No. 29	Testing Laboratory.
Bradford White Corporation	BWC	NOPR No. 33; SNOPR No. 48	Manufacturer.
Edison Electric Institute	EI	Transcript	Utility Trade Association.
GE Appliances	GEA	SNOPR No. 53	Manufacturer.
Jim Lutz	Lutz	NOPR No. 35	Individual.
Nathan Dyson	Dyson	NOPR No. 28	Individual.
New York State Energy Research and Development Authority ..	NYSERDA	NOPR No. 32; SNOPR No. 50	State Agency.
Northwest Energy Efficiency Alliance	NEEA	NOPR No. 30; SNOPR No. 56	Efficiency Advocacy Organization.
Nyle Water Heating Systems, LLC	Nyle	SNOPR No. 57	Manufacturer.
Pacific Gas and Electric Company, San Diego Gas and Electric, and Southern California Edison, collectively referred to as the "California Investor-Owned Utilities".	CA IOUs	NOPR No. 36; SNOPR No. 52	Utilities.
Rheem Manufacturing Company	Rheem	NOPR No. 31; Transcript; SNOPR No. 47.	Manufacturer.
SEA Groups, Ltd	SEA	NOPR No. 24	Manufacturer.
Stone Mountain Technologies, Inc	SMTI	SNOPR No. 49	Manufacturer.

* Note: The January 27, 2022 TP NOPR Public Meeting Transcript can be found in the docket for this rulemaking at www.regulations.gov under entry number EERE-2019-BT-TP-0032-0027. Comments arising from the public meeting will be cited as follows: (Commenter name, Jan. 27, 2022 Public Meeting Transcript, No. 27 at p. X).

A parenthetical reference at the end of a comment quotation or paraphrase provides the location of the item in the public record.¹⁶ To the extent that interested parties have provided written comments that are substantively similar to any oral comments provided during the NOPR public meeting, DOE cites the written comments throughout this final rule. Any oral comments provided during the webinar that are substantively distinct from a submitter's written comments are summarized and cited separately throughout this final rule.

APGA commented that DOE should adopt changes to its rulemaking process as outlined in a report by National Academies of Sciences, Engineering, and Medicine (NASEM) for both test procedures and standards. (APGA, No. 38 at p. 2) In response, the Department notes that the rulemaking process for test procedures of covered products and equipment are outlined at appendix A to subpart C of 10 CFR part 430, and DOE periodically examines and revises these provisions in separate rulemaking proceedings.

Section II of this document provides a synopsis of this final rule, and section III of this document discusses each

amendment to the test procedure for consumer water heaters and residential-duty commercial water heaters in detail.

II. Synopsis of the Final Rule

In this final rule, DOE amends appendix E and related sections of the CFR. In summary, the final rule:

1. Incorporates by reference current versions of industry standards: ASHRAE 41.1, ASHRAE 41.6, ASHRAE 118.2, ASTM D2156, and ASTM E97.
2. Adds definitions for "circulating water heater, "tabletop water heater, and "low-temperature water heater.
3. Harmonizes various aspects of the DOE test procedure with industry test procedures ASHRAE 118.2-2022 and NEEA Advanced Water Heating Specification v8.0.
4. Modifies the test condition specifications and tolerances, including electric supply voltage tolerance, ambient conditions (ambient dry-bulb temperature and ambient relative humidity), standard temperature and pressure definition, gas supply pressure, manifold pressure, inlet water temperature, and flow rate tolerances, and adds optional test conditions for heat pump water heaters.
5. Specifies and clarifies methods for mixing valve installation for affected

water heaters, orifice modification, and calculation of volume or mass delivered.

6. Defines the use of a separate unfired hot water storage tank or separate electric storage water heater for testing water heaters designed to operate with a separately sold tank.

7. Adds procedures for estimating internal stored water temperature for water heater designs in which the internal tank temperature cannot be directly measured.

8. Clarifies test procedures for water heaters with network connection capabilities.

9. Clarifies test procedures for flow-activated water heaters and water heaters that are not flow-activated by aligning terminology.

10. Includes additional testing provisions for electric resistance water heaters undergoing optional high temperature testing.

11. Includes a calculation for determining the effective storage volume of a water heater.

The adopted amendments are summarized in Table II.1 compared to the test procedure provision prior to the amendment, as well as the reason for the adopted change.

TABLE II.1—SUMMARY OF CHANGES IN THE AMENDED TEST PROCEDURE

DOE test procedure prior to amendment	Amended test procedure	Attribution
References the 1986 (Reaffirmed 2006) version of ASHRAE 41.1 for methods for temperature measurement.	References the updated 2020 version of ASHRAE 41.1	Industry TP Update to ASHRAE 41.1.
The 1982 version of ASHRAE 41.6 for methods for humidity measurement is referenced within the 1986 version of ASHRAE 41.1.	References the 2014 version of ASHRAE 41.6, which is referenced by ASHRAE 41.1-2020.	Industry TP Update to ASHRAE 41.6.

¹⁶ The parenthetical reference provides a reference for information located in the docket of DOE's rulemaking to develop test procedures for

consumer water heaters and residential-duty commercial water heaters. (Docket No. EERE-2019-BT-TP-0032, which is maintained at

www.regulations.gov). The references are arranged as follows: (commenter name, comment docket ID number, page of that document).

TABLE II.1—SUMMARY OF CHANGES IN THE AMENDED TEST PROCEDURE—Continued

DOE test procedure prior to amendment	Amended test procedure	Attribution
References the 2009 version of ASTM D2156 for testing smoke density in flue gases from burning distillate fuels.	References the version of ASTM D2156 that was reaffirmed in 2018.	Industry TP Update to ASTM D2156.
The 1987 version of ASTM E97 for testing directional reflectance factor, 45-deg 0-deg, of opaque specimens by broad-band filter reflectometry is referenced within ASTM D2156–09.	References the 1987 version of ASTM E97, which is referenced by ASTM D2156–09 (RA 2018).	Industry TP Update to ASTM E97.
Does not define a “circulating water heater” as used in 10 CFR 430.2.	Adds a definition for “circulating water heater” to 10 CFR 430.2.	Allow for testing certain consumer water heaters.
Does not define a “tabletop water heater” as used as a product class distinction at 10 CFR 430.32(d).	Adds a definition for “tabletop water heater” to 10 CFR 430.2.	Reinstate definition inadvertently removed by previous final rule.
Interprets the upper limit for consumer electric heat pump water heaters to be 12 kW of input, with “commercial heat pump water heater” defined at 10 CFR 431.102 as having rated electric power input greater than 12 kW.	Corrects the upper limit for consumer electric heat pump water heaters to 24 amperes at 250 volts of input and amends the definition for “commercial heat pump water heater” accordingly.	Make consistent with statutory definition.
Does not address how to configure a water heater for test when a mixing valve is required for proper operation.	Specifies how a mixing valve should be installed when the water heater is designed to operate with one.	Method added by DOE to improve repeatability.
Requires the flow rate during the FHR test to be 1.0 ± 0.25 gpm (3.8 ± 0.95 L/min) for water heaters with a rated storage volume less than 20 gallons.	Requires the flow rate during the FHR test to be 1.5 ± 0.25 gpm (5.7 ± 0.95 L/min) for water heaters with a rated storage volume less than 20 gallons.	Harmonization with industry TP ASHRAE 118.2–2022.
Does not address the situation in which the first recovery ends during a draw when testing to the 24-hour simulated-use test.	Clarifies that the first recovery period will extend to the end of the draw in which the first recovery ended, and that if a second recovery initiates prior to the end of the draw, that the second recovery is part of the first recovery period as well.	Harmonization with industry TP ASHRAE 118.2–2022.
The recovery efficiency equation for storage-type water heaters refers to the mass of water removed from the start of the test to the end of the first recovery period.	Clarifies that, for the calculation of recovery efficiency, the mass of water removed during the first recovery period includes water removed during all draws from the start of the test until the end of the first recovery period.	Harmonization with industry TP ASHRAE 118.2–2022.
The procedures for the standby period after the last draw of the 24-hour simulated-use test allow for a recovery to occur at the end of the 8-hour standby period, which indicates that the power to the main burner, heating element, or compressor is not disabled.	Clarifies the alternate approach to determine the energy consumed during the 24-hour simulated use test if a standby period occurs after the final draw of the test.	Harmonization with industry TP ASHRAE 118.2–2022.
Appendix E uses the phrases “storage-type” and “instantaneous-type” to refer to “non-flow activated” and “flow-activated” water heaters, respectively.	Uses the terms “non-flow activated” and “flow-activated” water heater, where appropriate.	Clarification.
The descriptions for $Q_{su,0}$, $Q_{su,f}$, $\bar{T}_{su,0}$, $\bar{T}_{su,f}$, $t_{stby,1}$, $\bar{T}_{l,stby,1}$, and $\bar{T}_{a,stby,1}$ only address when the standby period occurs between draw clusters 1 and 2.	The descriptions for $Q_{su,0}$, $Q_{su,f}$, $\bar{T}_{su,0}$, $\bar{T}_{su,f}$, $t_{stby,1}$, $\bar{T}_{l,stby,1}$, and $\bar{T}_{a,stby,1}$ are generalized to refer to the section where the standby period is determined.	Clarification.
Specifies that the first required measurement for each draw of the 24-hour simulated-use test is 5 seconds after the draw is initiated.	Specifies that the first required measurement for each draw of the 24-hour simulated-use test is 15 seconds after the draw is initiated.	Method updated by DOE to reduce burden.
Requires the electric supply voltage to be within ± 1 percent of the rated voltage for the entire test.	Requires the electric supply voltage to be within ± 2 percent of the rated voltage beginning 5 seconds after the start of a recovery and ending 5 seconds before the end of a recovery.	Method updated by DOE to reduce burden.
Requires maintaining ambient temperature for non-heat pump water heaters within a range of $67.5 \text{ }^\circ\text{F} \pm 2.5 \text{ }^\circ\text{F}$.	Requires maintaining the ambient temperature for non-heat pump water heaters within a range of $67.5 \text{ }^\circ\text{F} \pm 5 \text{ }^\circ\text{F}$, and with an average of $67.5 \text{ }^\circ\text{F} \pm 2.5 \text{ }^\circ\text{F}$.	Method updated by DOE to reduce burden.
Requires maintaining the dry-bulb temperature for heat pump water heaters within a range of $67.5 \text{ }^\circ\text{F} \pm 1 \text{ }^\circ\text{F}$.	Requires maintaining the dry-bulb temperature for heat pump water heaters within a range of $67.5 \text{ }^\circ\text{F} \pm 5 \text{ }^\circ\text{F}$, and with an average of $67.5 \text{ }^\circ\text{F} \pm 1 \text{ }^\circ\text{F}$ during recoveries and an average of $67.5 \text{ }^\circ\text{F} \pm 2.5 \text{ }^\circ\text{F}$ when not recovering.	Method updated by DOE to reduce burden.
Requires maintaining the relative humidity for heat pump water heaters within a range of 50 percent ± 2 percent.	Requires maintaining the relative humidity for heat pump water heaters within a range of 50 percent ± 5 percent, and at an average of 50 percent ± 2 percent during recoveries.	Method updated by DOE to reduce burden.
Requires that the heating value be corrected to a standard temperature and pressure, but does not state what temperature and pressure is standard or how to correct the heating value to the standard temperature and pressure.	States that the standard temperature is $60 \text{ }^\circ\text{F}$ ($15.6 \text{ }^\circ\text{C}$) and the standard pressure is 30 inches of mercury column (101.6 kPa). Provides a method for converting heating value from the measured to the standard conditions via incorporation by reference of ASHRAE 118.2–2022.	Harmonization with industry TP ASHRAE 118.2–2022.
Requires that the manifold pressure be within ± 10 percent of the manufacturer recommended value.	Clarifies that the manifold pressure tolerance applies only to water heaters with a pressure regulator that can be adjusted. Requires that the manifold pressure be within the greater of ± 10 percent of the manufacturer recommended value or ± 0.2 inches water column.	Method updated by DOE to reduce burden.
Does not specify the input rate at which the gas supply pressure tolerance is determined.	Specifies that the gas supply pressure tolerance is to be maintained when operating at the maximum input rate.	Method added by DOE to clarify enforcement test procedure.
Does not contain procedures for modifying the orifice of a water heater that is not operating at the manufacturer specified input rate.	Adds provisions regarding the modification of the orifice	Method added by DOE to clarify enforcement test procedure.
Does not specify how to calculate the mass removed from the water heater when mass is calculated indirectly using density and volume measurements.	Specifies how to calculate the mass of water indirectly using density and volume measurements.	Method added by DOE to improve repeatability.
Does not accommodate testing of “low-temperature water heaters” in appendix E.	Adds a definition of “low-temperature water heater” in 10 CFR 430.2 and requires low temperature water heaters to be tested to their maximum possible delivery temperature in appendix E.	Allow for testing certain consumer water heaters.

TABLE II.1—SUMMARY OF CHANGES IN THE AMENDED TEST PROCEDURE—Continued

DOE test procedure prior to amendment	Amended test procedure	Attribution
Does not explicitly define the test conditions required for each part of a split-system heat pump water heater.	Explicitly states that the heat pump part of a split-system heat pump water heater is tested at the dry-bulb temperature and relative humidity conditions required for heat pump water heaters, and that the storage tank is tested at the ambient temperature and relative humidity conditions required for non-heat pump water heaters.	Method added by DOE to improve representativeness and repeatability.
Does not accommodate testing of water heaters that require a separately-sold hot water storage tank to properly operate.	Requires that gas-fired circulating water heaters be tested using a UFHWST with a storage volume between 80 and 120 gallons and that meets but does not exceed the minimum energy conservation standards required according to 10 CFR 431.110(a), and that heat pump circulating water heaters be tested using a 40-gallon electric storage water heater at the minimum UEF standard required at 10 CFR 430.32(d).	Allow for testing certain consumer water heaters.
Does not address water heaters with network connection capabilities.	Explicitly states that any connection to an external network or control be disconnected during testing.	Clarification.
Does not accommodate certain water heaters for which the mean tank temperature cannot be directly measured.	Establishes a method of determining the internal storage tank temperature using draws at the beginning and end of the 24-hour simulated use test.	Allow for testing certain consumer water heaters.
10 CFR 429.70(g) does not allow untested electric instantaneous water heaters to be certified, but does allow untested electric storage water heaters to be certified.	Extends the untested provisions within 10 CFR 429.70(g) to include electric instantaneous water heaters.	AEDM allowed by DOE to reduce burden.
Does not specify flow rate tolerance for water heaters with rated storage volume less than 2 gallons.	Specifies that flow rates for all water heaters with rated storage volume less than 2 gallons must be maintained within a tolerance of ±0.25 gallons per minute. Additionally proposes that for water heaters with rated storage volume less than 2 gallons and a rated Max GPM of less than 1 gallon per minute, the flow rate tolerance shall be ±25 percent of the rated Max GPM.	Method added by DOE to improve repeatability and reproducibility.
Does not include optional efficiency representations at alternative test conditions for heat pump water heaters.	Allows for optional efficiency representations at alternative test conditions for heat pump water heaters.	Harmonization with industry TP NEEA Advanced Water Heating Specification v8.0.
Does not include a definition for “split-system heat pump water heater.”	Adds a definition for “split-system heat pump water heater” to distinguish these from heat pump-only water heaters.	Harmonization with industry TP NEEA Advanced Water Heating Specification v8.0.
Specifies that water heaters with multiple modes of operation be tested in the “default” or other similarly named mode.	Provides a test method for electric resistance water heaters subject to high temperature testing (setting the water heater to the highest storage tank temperature and using a mixing valve to temper the delivery water to be within 125 ± 5 °F). Does not require the use of this type of testing for any water heaters, however, until compliance with amended standards is required.	Method added by DOE to improve representativeness.
Does not include any method to determine effective storage volume of storage-type water heaters or circulating water heaters.	Establishes a metric and method for determining the effective storage volume of storage-type water heaters and circulating water heaters.	Method added by DOE which adopts a metric for additional consumer information.
Does not include a definition for “thermal break.”	Adopts a definition for “thermal break” but does not mandate the use of this component in test set-up.	Harmonization with industry TP ASHRAE 118.2–2022.

DOE has determined that the amendments described in section III and adopted in this document will not alter the measured efficiency of consumer water heaters and residential-duty commercial water heaters, or require retesting or recertification solely as a result of DOE’s adoption of the amendments to the test procedures. Discussion of DOE’s actions are addressed in detail in section III of this document.

The effective date for the amended test procedures adopted in this final rule is 30 days after publication of this document in the **Federal Register**. Representations of energy use or energy efficiency must be based on testing in accordance with the amended test procedures beginning 180 days after the publication of this final rule for consumer water heaters and 360 after the publication of this final rule for residential-duty commercial water heaters.

III. Discussion

A. Scope of Applicability and Definitions

This document covers those products that meet the definition of consumer “water heaters,” as defined in the statute at 42 U.S.C. 6291(27), as codified at 10 CFR 430.2. This document also covers commercial water heating equipment with residential applications (*i.e.*, those water heaters which meet the definition of “residential-duty commercial water heater” at 10 CFR 431.102).

In the context of covered consumer products, EPCA defines “water heater” as a product which utilizes oil, gas, or electricity to heat potable water for use outside the heater upon demand, including—

(a) Storage type units which heat and store water at a thermostatically controlled temperature, including gas storage water heaters with an input of

75,000 Btu per hour or less, oil storage water heaters with an input of 105,000 Btu per hour or less, and electric storage water heaters with an input of 12 kilowatts or less;

(b) Instantaneous type units which heat water but contain no more than one gallon of water per 4,000 Btu per hour of input, including gas instantaneous water heaters with an input of 200,000 Btu per hour or less, oil instantaneous water heaters with an input of 210,000 Btu per hour or less, and electric instantaneous water heaters with an input of 12 kilowatts or less; and

(c) Heat pump type units, with a maximum current rating of 24 amperes at a voltage no greater than 250 volts, which are products designed to transfer thermal energy from one temperature level to a higher temperature level for the purpose of heating water, including all ancillary equipment such as fans, storage tanks, pumps, or controls

necessary for the device to perform its function.

(42 U.S.C. 6291(27); 10 CFR 430.2)

In addition, at 10 CFR 430.2, DOE defines several specific categories of consumer water heaters, as follows:

(1) “Electric instantaneous water heater” means a water heater that uses electricity as the energy source, has a nameplate input rating of 12 kW or less, and contains no more than one gallon of water per 4,000 Btu per hour of input.

(2) “Electric storage water heater” means a water heater that uses electricity as the energy source, has a nameplate input rating of 12 kW or less, and contains more than one gallon of water per 4,000 Btu per hour of input.

(3) “Gas-fired instantaneous water heater” means a water heater that uses gas as the main energy source, has a nameplate input rating less than 200,000 Btu/h, and contains no more than one gallon of water per 4,000 Btu per hour of input.

(4) “Gas-fired storage water heater” means a water heater that uses gas as the main energy source, has a nameplate input rating of 75,000 Btu/h or less, and contains more than one gallon of water per 4,000 Btu per hour of input.

(5) “Grid-enabled water heater” means an electric resistance water heater that—

(a) Has a rated storage tank volume of more than 75 gallons;

(b) Is manufactured on or after April 16, 2015;

(c) Is equipped at the point of manufacture with an activation lock and;

(d) Bears a permanent label applied by the manufacturer that—

(i) Is made of material not adversely affected by water;

(ii) Is attached by means of non-water-soluble adhesive; and

(iii) Advises purchasers and end-users of the intended and appropriate use of the product with the following notice printed in 16.5 point Arial Narrow Bold font: “IMPORTANT INFORMATION: This water heater is intended only for use as part of an electric thermal storage or demand response program. It will not provide adequate hot water unless enrolled in such a program and activated by your utility company or another program operator. Confirm the availability of a program in your local area before purchasing or installing this product.”

(6) “Oil-fired instantaneous water heater” means a water heater that uses oil as the main energy source, has a nameplate input rating of 210,000 Btu/h or less, and contains no more than one gallon of water per 4,000 Btu per hour of input.

(7) “Oil-fired storage water heater” means a water heater that uses oil as the main energy source, has a nameplate input rating of 105,000 Btu/h or less, and contains more than one gallon of water per 4,000 Btu per hour of input.

The definition for “grid-enabled water heater” includes the term “activation lock,” which is defined to mean a control mechanism (either by a physical device directly on the water heater or a control system integrated into the water heater) that is locked by default and contains a physical, software, or digital communication that must be activated with an activation key to enable the product to operate at its designed

specifications and capabilities and without which the activation of the product will provide not greater than 50 percent of the rated first-hour delivery of hot water certified by the manufacturer. 10 CFR 430.2. As specified in this definition, the control mechanism must be physically incorporated into the water heater or, if a control system, integrated into the water heater to qualify as an activation lock. DOE is aware of certain State programs that encourage water heaters to be equipped with communication ports that allow for demand-response communication between the water heater and the utility.¹⁷ DOE notes that presence of such a communication port, in and of itself, would not qualify as an activation lock for the purpose of classifying a water heater as a grid-enabled water heater. Demand-response water heaters are discussed separately in section III.A.1 of this final rule.

Additionally, as discussed further in section III.A.3 of this document, the appendix E test procedure also applies to residential-duty commercial water heaters. (See 10 CFR 431.106(b)(1)) DOE defines these equipment categories at 10 CFR 431.102 as any gas-fired storage, oil-fired storage, or electric instantaneous commercial water heater that meets the following conditions:

(1) For models requiring electricity, uses single-phase external power supply;

(2) Is not designed to provide outlet hot water at temperatures greater than 180 °F; and

(3) Does not meet any of the following criteria:

Water heater type	Indicator of non-residential application
Gas-fired Storage	Rated input >105 kBtu/h; Rated storage volume >120 gallons.
Oil-fired Storage	Rated input >140 kBtu/h; Rated storage volume >120 gallons.
Electric Instantaneous	Rated input >58.6 kW; Rated storage volume >2 gallons.

In the January 2022 NOPR, DOE discussed definitions and the scope of appendix E for heat pump water heaters (electric as well as gas-fired), gas-fired instantaneous water heaters (specifically circulating gas-fired water heaters), tabletop water heaters, and residential-duty commercial water heaters. 87 FR

1554, 1560–1567 (Jan. 11, 2022). Additionally, DOE proposed a new definition for “demand-response water heater” in the July 2022 SNOFR. 87 FR 42270, 42280 (July 14, 2022).

BWC generally agreed with DOE’s determinations regarding product and equipment definitions and

classifications. (BWC, No. 33 at p. 1) AET generally commented that DOE’s test procedures should be appropriate for all consumer water heaters within the scope of standards, especially for electric instantaneous water heaters. (AET, No. 29 at pp. 11–12)

¹⁷ On May 7, 2019, the State of Washington signed House Bill 1444 which amended the Revised Code of Washington (RCW) (*i.e.*, the statutory code in the State of Washington), Title 19, Chapter 19.260 (RCW 19.260). On January 6, 2020, the State of Washington amended the Washington Administrative Code (WAC) (*i.e.*, the regulatory code in the State of Washington), Title 194, Chapter 194–24 (WAC 194–24) (Washington January 2020 Amendment) to align with RCW 19.260. Similarly, the State of Oregon published a final rule (Oregon

August 2020 final rule) on August 8, 2020, which amended the Oregon Administrative Rules (OAR), Chapter 330, Division 92 (OAR–330–092). The Washington House Bill 1444 and the Oregon August 2020 final rule established a definition for electric storage water heater (RCW 19.260.020(14); OAR–330–092–0010(10)), an effective date of January 1, 2021 in Washington and January 1, 2022 in Oregon (RCW 19.260.080(1); OAR–330–092–0015(17)), a requirement that electric storage water heaters must have a modular demand response communications

port compliant with the March 2018 version of the ANSI/CTA–2045–A communication interface standard, or a standard determined to be equivalent (RCW 19.260.080(1)(a)–(b); OAR–330–092–0020(17)), and, in Oregon, must bear a label or marking on the products stating either “DR-ready: CTA–2045–A” or “DR-ready: CTA–2045–A and [equivalent DR system protocol]” (OAR–330–092–0045(17)).

As discussed throughout this rulemaking, it is DOE's intention to ensure that the appendix E test procedure amended by this final rule is appropriate and applicable to all consumer water heaters and residential-duty commercial water heaters. Sections III.A.1 through III.A.4 of this document address specific issues related to scope and definitions that either DOE requested comment on in the January 2022 NOPR or July 2022 SNO PR, or that were identified by commenters in response to those documents.

1. Demand-Response Water Heaters

Storage-type water heaters that have "connected" capability, often referred to as "demand-response" water heaters, can be remotely activated and/or deactivated by signals from a utility company or another program operator, and are able to serve as a thermal energy storage device. DOE considered whether specific testing requirements would be appropriate for demand-response water heaters (such as requiring measurement of the energy consumed by connected features, or providing a method for calculating the amount of thermal energy storage available); however, DOE had tentatively determined that additional test procedure provisions (such as the calculation of a thermal energy storage metric) are premature and unnecessary to specify at this time as the market continues to develop and evolve. DOE proposed only that a provision be added to the test procedure to require that if a water heater can connect to an external network or controller, that communication shall be disabled during testing. 87 FR 1554, 1585–1586 (Jan. 11, 2022). Several stakeholders provided input on this tentative determination.

NEEA encouraged DOE to adopt definitions and test methods for "connectable" water heaters in the test procedure. The commenter pointed to the following existing and emerging standards as references: Consumer Technology Association (CTA) Standard 2045 (ANSI/CTA–2045)/EcoPort,¹⁸ U.S. Environmental Protection Agency (EPA) ENERGY STAR connected device requirements, and AHRI 1430, *Standard for Demand Response for Electric Water Heaters*.¹⁹ NEEA stated that definitions

¹⁸ Available online at: shop.cta.tech/products/https-cdn-cta-tech-cta-media-media-ansi-cta-2045-b-final-2022-pdf (Last accessed on Sept. 17, 2022).

¹⁹ AHRI Standard 1430, "Standard for Demand Response for Electric Water Heaters," was published in December 2022. It is an industry consensus standard developed by an AHRI Consensus Standards Project Committee that includes definitions, test requirements, operating and physical requirements, minimum data requirements for published ratings, marking and

of connectivity have already been adopted by the States of Washington, Oregon, and California as part of their water heating appliance standards. (NEEA, No. 30 at pp. 2–3) The CA IOUs recommended the adoption of a definition for the communication capability for grid-enabled water heaters that is consistent with the Connected Product Criteria in the ENERGY STAR Product Specification for Residential Water Heaters.²⁰ The CA IOUs also recommended that DOE incorporate the associated ENERGY STAR connected products test procedure into the appendix E test procedure. (CA IOUs, No. 36 at pp. 2–3)

In response, DOE considered these comments and also assessed the operation of demand-response water heaters as grid thermal energy storage devices using specific communication protocols in order to determine how to distinguish these products from other water heaters capable of storage tank overheating. On July 18, 2022, EPA published an ENERGY STAR Version 5.0 Residential Water Heater Specification, which included definitions for "connected water heater product" and "demand response." These definitions included references to Consumer Technology Association (CTA) Standard 2045 (ANSI/CTA–2045),²¹ a design standard for a communications module that allows a water heater to receive signals from a utility company (e.g., a curtailment request). As indicated by NEEA and the CA IOUs, the presence of a CTA–2045 port uniquely enables a water heater to be able to participate in any demand-response program, and DOE has additionally determined that products

nameplate, and data and conformance conditions for demand-response electric water heaters. For more information, see www.ahrinet.org/search-standards/ahri-1430-demand-flexible-electric-storage-water-heaters (Last accessed on Feb. 17, 2023).

²⁰ According to version 5.0 of the ENERGY STAR Program Requirements for Residential Water Heaters Eligibility Criteria, a "connected water heater product (CWHP)" includes the ENERGY STAR certified water heater, integrated or separate communications hardware, and additional hardware and software required to enable connected functionality. "Demand Response" is also defined by that source to mean changes in electric or gas usage by end-use customers from their normal consumption patterns in response to changes in the price of electricity or gas over time, or to incentive payments designed to induce lower electricity or gas use at times of high wholesale market prices or when system reliability is jeopardized. Version 5.0 of the ENERGY STAR specification is available online at: www.energystar.gov/products/spec/residential_water_heaters_specification_version_5_0_pd (Last accessed on July 25, 2022).

²¹ See section 4.D.a of the ENERGY STAR Version 5.0 specification.

with these features are increasing in number.

In the July 2022 SNO PR, DOE noted that certain new water heaters were available on the market that are shipped from the point of manufacture with a mixing valve installed and intentionally "overheat"²² the water to a stored temperature that is higher than the delivery temperature setpoint to provide additional capacity.²³ 87 FR 42270, 42279–42280 (July 14, 2022). DOE proposed specific test requirements for such products (see section III.E.1 of this document for discussion). DOE also noted that water heaters with demand-response capabilities may undergo utility-initiated overheating during certain periods to store additional energy in the water heater during peak demand periods, and tentatively determined that the test provisions proposed for water heaters that overheat may not be appropriate for demand-response water heaters that overheat. *Id.* To distinguish demand-response water heaters from other types capable of overheating, DOE proposed to define a "demand-response water heater" as follows:

Demand-response water heater means a storage-type water heater that—

1. Has integrated communications hardware and additional hardware and software required to enable connected functionality with a utility or third party, that dispatches signals with demand response instructions and/or price signals to the product and receives messages from the demand-response water heater;

2. Meets the communication and equipment standards for Consumer Technology Association (CTA) Standard 2045–B (ANSI/CTA–2045–B);²⁴

3. Automatically heats the stored water above the delivery temperature setpoint only in response to instructions received from a utility or third party. 87 FR 42270, 42280 (July 14, 2022). DOE sought comment on this proposed definition. *Id.*

²² The term "overheating" refers to raising the tank temperature above the outlet water setpoint and does not denote performance outside of the normal operating range of the water heater.

²³ While typical water heaters do not store water warmer than the outlet temperature setpoint (which is, on average, 125 ± 5 °F), water heaters designed to increase energy storage capacity may overheat the tank to temperatures such as 140–150 °F and use a mixing valve to temper the outlet water down to the setpoint condition. The energy storage capacity is proportional to both the size of the tank and the temperature of the water within.

²⁴ ANSI/CTA–2045–B, "Modular Communications Interface for Energy Management," published February 2021. (Available at: shop.cta.tech/products/https-cdn-cta-tech-cta-media-media-ansi-cta-2045-b-final-2022-pdf) (Last accessed Sept. 17, 2022).

In response to the July 2022 SNOPR, AHRI, A.O. Smith, BWC, and Rheem recommended that DOE change its definition of “demand-response water heater” to be consistent with ENERGY STAR and AHRI Standard 1430.²⁵ (AHRI, No. 55 at p. 7; A.O. Smith, No. 51 at pp. 6–7; BWC, No. 48 at p. 2; Rheem, No. 47 at p. 6) Specifically, AHRI and A.O. Smith requested that DOE define “demand-flexible water heater” as “an electric resistance storage water heater or heat pump water heater with the capability to reduce, shed, shift, load up, and modulate energy consumption in response to a command or instructions received from a utility or third party.” (AHRI, No. 55 at p. 7; A.O. Smith, No. 51 at pp. 6–7) BWC requested that DOE use the ENERGY STAR and AHRI Standard 1430 definitions of “demand-response” to avoid manufacturer burden and allow for easier future development of these products. (BWC, No. 48 at p. 2) Rheem further recommended that DOE seek direct feedback from EPA’s ENERGY STAR program. (Rheem, No. 47 at p. 6)

NYSERDA pointed out that DOE’s proposed definition for “demand-response water heater,” which states that it cannot overheat as a result of user-initiated operation, is an additional requirement beyond ENERGY STAR’s definitions. Accordingly, NYSERDA urged DOE to define “overheating test exempt water heaters” so as to avoid creating market confusion, and the commenter recommended that DOE consider the power usage for connectedness as included in the ENERGY STAR water heater specification, as it would allow utilities to plan more effectively, encourage the additional load to be minimal, and inform consumers regarding anticipated operating costs. (NYSERDA, No. 50 at p. 2)

NEEA indicated support for DOE’s proposed definition of “demand-response water heater” and the proposal for demand-response water heaters to meet the communication and equipment standards for ANSI/CTA–2045. (NEEA, No. 56 at pp. 2–3) AHRI, however, indicated that DOE’s definition would require compliance with the demand-response program the water heater is enrolled in, whereas other, non-DOE definitions allow consumers to opt out. (AHRI, No. 55 at p. 7) BWC and Rheem requested that DOE remove the requirement to comply with CTA–2045.

(BWC, No. 48 at pp. 1–2, Rheem, No. 47 at p. 6) BWC stated that requiring compliance with CTA–2045 may prevent manufacturers from designing their products around separate and future protocols. (BWC, No. 48 at pp. 1–2)

Rheem recommended that DOE’s definition acknowledge the fact that many water heaters with demand-response capability are currently shipped without all necessary hardware to participate in a demand-response program. Rheem also suggested that DOE’s definition does not cover most demand-response water heaters because it excludes water heaters without the ability to heat water above the setpoint. (Rheem, No. 47 at p. 6)

After reviewing these comments from stakeholders, DOE understands that, for the purpose of demand-response programs, utilities and manufacturers would benefit from a standardized definition of “demand-response water heater,” specifically one that requires certain communications protocols to be present in order to be compatible with the demand-response signals from the utility or third-party. Stakeholders have indicated that, in order to be deemed a “demand-response water heater,” a product must demonstrate that it is capable of executing the commands from the demand-response signals (*i.e.*, pass the verification tests in the ENERGY STAR Test Method to Validate Demand Response or in AHRI Standard 1430). However, DOE proposed a more limited definition for “demand-response water heater” in the July 2022 SNOPR, seeking only to describe the types of water heaters that could temporarily increase the storage tank temperature as a means to perform a load up²⁶ such that this particular operation would not be considered “overheating” in the appendix E test procedure (*see* 87 FR 42270, 42280 (July 14, 2022)). This led DOE to revisit its proposed definition and to reassess its planned approach.

As a result, in this final rule, DOE has decided not to establish a definition for “demand-response water heater.” DOE has considered the various requirements which stakeholders suggested should be criteria for a product to be called a “demand-response water heater” and has determined that, while

standardization of these requirements may be beneficial to utilities and industry, it is unnecessary at this time because DOE can instead describe the types of water heaters that can temporarily increase the storage tank temperature only in response to instructions from a utility or third-party demand response program without defining “demand-response water heater”. Additionally, as discussed in section III.E.1.b of this document, this final rule only amends the test procedure to provide a means for testing water heaters in the highest tank temperature setting, and DOE is adopting it as a voluntary measure in this test procedure for certain electric storage water heaters. As such, it is no longer necessary to establish a definition for “demand-response water heater” in this test procedure rulemaking.

2. Heat Pump Water Heaters

As discussed in section III.A of this document, EPCA defines “water heater” to include, in relevant part, (A) storage type units which heat and store water at a thermostatically controlled temperature, including . . . electric storage water heaters with an input of 12 kilowatts or less; (B) instantaneous type units which heat water but contain no more than one gallon of water per 4,000 Btu per hour of input, including . . . electric instantaneous water heaters with an input of 12 kilowatts or less; and (C) heat pump type units, with a maximum current rating of 24 amperes at a voltage no greater than 250 volts, which are products designed to transfer thermal energy from one temperature level to a higher temperature level for the purpose of heating water, including all ancillary equipment such as fans, storage tanks, pumps, or controls necessary for the device to perform its function. (42 U.S.C. 6291(27))

Because the maximum current and voltage ratings for consumer heat pump type units are 24 amperes at no more than 250 volts, the maximum electrical input for this type of product is determined to be 6 kilowatts.²⁷ In this final rule, DOE is providing clarifications on how these definitions apply to electric and gas-fired heat pump storage water heaters.

a. Electric Heat Pump Storage Water Heaters

EPCA is not explicit as to whether heat pump type units are considered a subcategory of storage type units and

²⁵ AHRI Standard 1430–2022 (I–P), “2022 Standard for Demand Flexible Water Heaters,” published December 2022. (Available at: <https://www.ahrinet.org/search-standards/ahri-1430-demand-flexible-electric-storage-water-heaters>.) (Last accessed Feb. 17, 2023)

²⁶ According to the ENERGY STAR Test Method to Validate Demand Response v1.2, a connected water heating product is required to use and/or store additional thermal energy that the device otherwise would not have used/stored under normal operation in response to a load up request. This allows the stored thermal energy to increase within the safety parameters determined by the manufacturer, and, for installations with a mixing valve, the device may exceed the user set point temperature.

²⁷ Power equals current times voltage, so the definition of consumer heat pump type unit corresponds to a maximum power rating of 6,000 W, or 6 kW (*i.e.*, 24 A times 250 V equals 6,000 W).

instantaneous type units. “Storage type units” and “instantaneous type units” are not exclusive of “heat pump type units.” Based on the statute’s “water heater” definition, an electric heat pump type unit could be covered under the “water heater” definition’s description of storage type units (if it heats and stores water at a thermostatically controlled temperature with an input of 12 kilowatts or less) or instantaneous type unit (if it heats water and contains no more than one gallon of water per 4,000 Btu per hour of input and has an input of 12 kilowatts or less).

On November 10, 2016, DOE published a final rule in the **Federal Register** (the November 2016 Final Rule) that treated heat pump-type units as a subcategory of the other two types of units listed in the definition of water heater. Specifically, DOE stated in the November 2016 final rule that a heat pump water heater with a total rated input of less than 12 kilowatts would be a consumer water heater because EPCA classifies electric water heaters with less than 12 kilowatts rated electrical input as consumer water heaters. 81 FR 79261, 79301–79302. In the January 2022 NOPR, DOE responded to comments requesting clarification on whether electric heat pump water heaters between 6 kilowatts and 12 kilowatts of input should be classified as consumer water heaters or commercial water heaters. 87 FR 1554, 1561–1563 (Jan. 11, 2022). Upon further review of EPCA and the water heater market, DOE initially determined in the January 2022 NOPR that the interpretation presented in the November 2016 Final Rule was not the best reading of EPCA. *Id.*

In the January 2022 NOPR, DOE explained that the structure of the statutory definition of “water heater” in the Energy Conservation Program for Consumer Products in Part A of EPCA lists each type of water heater at equal subparagraph designations. Therefore, when defining “water heater” for the purpose of determining whether a water heater is a consumer water heater, the energy use criteria specified for heat pump-type units is to be applied separately and distinctly from the criteria specified for the categorizations of storage-type units and instantaneous-type units. Therefore, DOE had tentatively determined that heat pump water heaters, which operate with a maximum current rating greater than 24 amperes or at a voltage greater than 250 volts, are more appropriately covered as commercial water heaters than consumer water heaters. 87 FR 1554, 1561–1562 (Jan. 11, 2022).

As explained in the January 2022 NOPR, there are three other reasons why

DOE tentatively concluded that the revised interpretation would be more applicable to the residential water heater market.

First, heat pump technology is capable of providing heat output which exceeds the energy input. A heat pump type unit with an input rate of 12 kilowatts could have a heating capacity (*i.e.*, output capacity) of approximately 42 kilowatts, which is 3.6 times the output heating capacity provided by the largest possible consumer electric storage type water heater (*i.e.*, 11.8 kilowatts).²⁸ While a heat pump-type unit with a 12 kilowatt input capacity could theoretically be designed and installed in a residential application, its water heating capacity (*i.e.*, output capacity) would far exceed the water heating demand of any residential installation. 87 FR 1554, 1562 (Jan. 11, 2022).

Second, the DOE test procedure for consumer water heaters at the time of the November 2016 Final Rule only covered heat pump water heaters which have “a maximum current rating of 24 amperes (including the compressor and all auxiliary equipment such as fans, pumps, controls, and, if on the same circuit, any resistive elements) for an input voltage of 250 volts or less,” and, therefore, electric heat pump water heaters with greater than 24 amperes at 250 volts were not considered at the time when the current energy conservation standards for consumer water heaters were established (April 2010). As a result, these current standards do not reflect energy usage for heat pump water heaters between 6 kilowatts and 12 kilowatts, and such products are more appropriately rated to the commercial water heater test procedure (10 CFR 431.106) and evaluated against the maximum standby loss standards for this equipment (10 CFR 431.110(a)). 87 FR 1554, 1562 (Jan. 11, 2022).

Third, based on its review of the market, DOE is aware of integrated heat pump water heaters, split-system heat pump water heaters, and heat pump-only water heaters (*i.e.*, circulating heat pump water heaters) which are designed for use in residential applications, and all such products are rated at or below 24 A/250 V of input. Integrated heat

pump water heaters, which consist of an air-source heat pump in one assembly with a storage tank, typically operate with 240-volt input. Although integrated heat pump water heaters usually have backup 4.5-kilowatt electric resistance heating elements, the elements do not operate simultaneously, which ensures that these products do not surpass 6 kilowatts of input or 24 A/250 V at any given time. Some integrated heat pump water heaters are designed to operate at only 120 volts of input (*i.e.*, “retrofit-ready,” “plug-in,” or “120-volt” heat pump water heaters). Split-system heat pump water heaters, which consist of a separate heat pump and storage tank that are sold together (where the heat pump components are usually situated outdoors), are also covered by the currently applicable appendix E test procedure and have electrical input ratings which do not exceed 24 A/250 V. Circulating heat pump water heaters (or “heat pump-only” water heaters), which consist of only a heat pump module and must be installed with a separate storage tank, similarly do not exceed this limit, and there are models of circulating heat pump water heaters which are intended to operate on 120 volts of input.

Alternative source heat pump water heaters (*e.g.*, ground-source or water-source), were not considered in this rulemaking due to their predominant use as commercial products. 87 FR 1554, 1563 (Jan. 11, 2022).

In this final rule, DOE maintains the revised interpretation as discussed in the January 2022 NOPR. To clarify this interpretation in the regulatory definitions, DOE is amending the definition of “commercial heat pump water heater” at 10 CFR 431.102 to reflect this revised interpretation. The revised definition reads: “*Commercial heat pump water heater (CHPWH)* means a water heater (including all ancillary equipment such as fans, blowers, pumps, storage tanks, piping, and controls, as applicable) that uses a refrigeration cycle, such as vapor compression, to transfer heat from a low-temperature source to a higher-temperature sink for the purpose of heating potable water, and operates with a current rating greater than 24 amperes or a voltage greater than 250 volts. Such equipment includes, but is not limited to, air-source heat pump water heaters, water-source heat pump water heaters, and direct geo-exchange heat pump water heaters.”

In the April 2020 RFI, DOE requested feedback on the need for creating a separate definition for “electric heat pump storage water heater,” similar to the definition in the March 2019

²⁸ A 12-kW electric resistance water heater with an assumed recovery efficiency of 98 percent would have an output heating capacity of 11.8 kW (12 kW × 0.98 = 11.8 kW). An electric heat pump-type water heater with a 12-kW input capacity, with an assumed recovery efficiency of 350 percent, would have an output heating capacity of 42 kW (12 kW × 3.5 = 42 kW), which is 3.6 times greater than the 11.8 kW output heating capacity of an electric resistance water heater with equivalent input capacity.

ASHRAE Draft 118.2, or whether the current DOE definitions in 10 CFR 430.2 for “electric storage water heater” and “water heater,” which include “heat pump type units,” would adequately cover such products for the purpose of performing the DOE test procedure. 85 FR 21104, 21110 (April 16, 2020). The Department’s tentative determination in the January 2022 NOPR was that a separate definition would not be needed because the current definitions were sufficient to describe these products. 87 FR 1554, 1563–1564 (Jan. 11, 2022). In response to the January 2022 NOPR, Rheem requested that the product class-specific definitions include or refer to the “heat pump type” requirements in EPCA. (Rheem, No. 31 at p. 2) BWC agreed with DOE’s assessment that consumer heat pump water heaters operate at no greater than 24 amperes at 250 volts. (BWC, No. 33 at pp. 1–2)

Additionally, DOE received several comments on the January 2022 NOPR regarding definitions for specific types of heat pump water heaters used in residential applications.

The CA IOUs recommended that DOE should supplement its test procedure definitions to address heat pump water heaters rated to operate at 120 volts of input. More specifically, the CA IOUs recommended that DOE develop a separate definition for 120-volt heat pump water heaters in the test procedure and consider any distinguishing characteristics that might require changes to the test procedure to represent their real-world performance accurately. These commenters argued that a separate definition would allow for the possibility of separate energy conservation standards for these products. The CA IOUs stated that they expect the first 120-volt heat pump water heaters to appear on the retail market in 2022 and noted that the California Energy Commission recently adopted a goal to install six million heat pumps (for space and water heating) by 2030, many of which they anticipate will be 120-volt heat pump water heaters. (CA IOUs, No. 36 at p. 4)

AET expressed support for the inclusion of heat pump-only water heaters within the scope of the DOE test procedure but suggested revising the terminology so as to differentiate a “heat pump water heater without a tank” from a “heat pump water heater with a tank.” (AET, No. 29 at p. 2) On this point, DOE notes that there is not yet a particular term for these products defined at 10 CFR 430.2 or in appendix E. These products may be referred to using any of the terms mentioned by AET, but the clearest description of these products is “circulating heat pump water heaters.”

Circulating water heaters are discussed further in section III.A.4.a of this document. DOE is adopting a definition for “circulating water heater” in this final rule, which will include these products.

Rheem recommended that DOE include split-system heat pump water heaters in the “water heaters requiring a storage tank” definition proposed in the January 2022 NOPR and that DOE define “integrated heat pump water heater” to distinguish them from split-system water heaters. (Rheem, No. 47 at p. 4) AHRI stated that a definition of “split-system water heater” is not required if DOE does not include the proposed optional additional test conditions in this rulemaking. (AHRI, No. 55 at p. 5)

In response to Rheem’s comments, a split-system water heater is not necessarily a “water heater requiring a storage tank,” as proposed in the January 2022 NOPR, because for a water heater to meet the proposed definition of “water heater requiring a storage tank” would mean there is no storage tank specified or supplied by the manufacturer but that it requires one for testing and operation. A split-system water heater, however, may have a manufacturer supplied or specified tank and, as such, would not necessarily fall under the definition of a “water heater requiring a storage tank.” When the tank is specified or supplied by the manufacturer, that tank should be used for testing, rather than a water heater or storage tank that meets the default conditions that were proposed to be added in section 4.10 of appendix E. Additionally, in response to the suggestion that DOE define “integrated heat pump water heater,” DOE notes that, as discussed later in this section, it is modifying the definition of a “split-system water heater” based on comments to mean a heat pump-type water heater in which at least the compressor, which may be installed outdoors, is separate from the storage tank. Therefore, heat pump water heaters that do not fall under the definition of “split-system water heater” adopted in this final rule would be integrated heat pump water heaters, as the refrigeration components would be integrated with the tank. Thus, it is unnecessary to separately define “integrated heat pump water heaters,” and the term would not be used in the test method. Creating additional definitions for this configuration may lead to confusion. In response to AHRI’s comment, as discussed and for the reasons explained in section III.C.7 of this document, DOE has decided to include the proposed optional

additional test conditions in this rulemaking, and, thus, the Department has defined the term “split-system water heater.”

A.O. Smith requested that DOE clearly define “heat pump-only water heater” and elucidate how appendix E applies to them. (A.O. Smith, No. 51 at p. 5) BWC requested that DOE clarify in its definitions the difference between split-system and heat pump-only water heaters. (BWC, No. 48 at p. 1)

In response, a heat pump-only water heater is considered a circulating water heater, which is a type of heat pump water heater, falls under the circulating water heater product classes, and is covered under the associated provisions of appendix E. Such distinctions were previously discussed in the January 2022 NOPR. 87 FR 1554, 1565 (Jan. 11, 2022). These units have an input greater than or equal to 4,000 Btu per hour per gallon, and accordingly, they are considered instantaneous water heaters. In contrast, split-system heat pump water heaters (which, unlike heat pump-only units, are distributed with a storage tank) are considered storage water heaters.

After considering these comments, DOE has decided to affirm coverage in this test procedure final rule for all of the aforementioned types of consumer heat pump water heaters. In particular, DOE has determined that the current definitions of “heat pump-type” and “electric storage water heater” adequately cover the electric heat pump water heaters on the market that are representative of residential use (including, but not limited to, integrated 240-volt and 120-volt heat pump water heaters, split-system heat pump water heaters, and circulating heat pump water heaters), and that a separate definition for “electric heat pump water heaters” is not needed in order to appropriately characterize the test procedure for consumer water heaters and residential-duty commercial water heaters.

At the time of this final rule, DOE is only aware of a small number of 120-volt integrated heat pump water heaters and circulating heat pump water heaters on the market. Therefore, DOE has limited information to determine whether there are any distinguishing characteristics of these products which would necessitate tailored test procedure requirements in order to produce ratings that are representative, reproducible, and repeatable. One manufacturer has publicly certified

ratings²⁹ for 120-volt electric storage heat pump models using the currently applicable appendix E test procedure (without the use of a test procedure waiver), so DOE, therefore, concludes that the appendix E test procedure is appropriate and representative for these models. DOE is aware, however, that default mode operation of 120-volt electric storage heat pump water heaters may require raising the tank temperature above the delivery setpoint in order to meet consumer expectations of first hour rating (FHR), and further discussion of potential impacts of storage tank overheating on ratings for 120-volt electric storage heat pump water heaters as a result of this final rule's action can be found in section III.E.1 and III.J.3 of this document.

In response to the July 2022 SNOPR, which proposed optional ambient test conditions and new definitions for “split-system water heaters,” AHRI and A.O. Smith requested that DOE change its definition of “split-system water heater” to the definition used by ENERGY STAR, which specifies that the compressor, evaporator, and/or condenser are separated from a storage tank that is specified by the manufacturer and rated as a single system. (AHRI, No. 55 at p. 5; A.O. Smith, No. 51 at p. 4) A.O. Smith offered an alternative definition to DOE's earlier definition of “split-system heat pump water heater” which specified the heat pump as being an outdoor component. (A.O. Smith, No. 51 at pp. 4–5)

A.O. Smith, NEEA, and the CA IOUs stated that it is unnecessary for the definition of “split-system water heater” to specify the location of specific components and requested that DOE eliminate the distinction between indoor and outdoor components. (A.O. Smith, No. 51 at p. 5; CA IOUs, No. 52 at pp. 4–5; NEEA, No. 56 at p. 2) The CA IOUs stated that the compressor should be specified as the component separate from the storage tank, rather than the heat pump, to more generally reflect split-system water heaters. (CA IOUs, No. 52 at pp. 4–5)

NEEA additionally recommended that DOE should not include references to “indoor” or “outdoor” in its proposed definition of “split-system heat pump water heater,” as outdoor installation of the heat pump component does not necessarily follow the splitting of heating and storage functions into separate components, and an all-indoor

split-system HPWH has the potential to provide significant benefits to consumers. NEEA added that adopting a split-system definition that excludes such products could hinder manufacturers in bringing them to market. (NEEA, No. 56 at p. 2) Similarly, Nyle commented that the proposed definition is problematic because not all split-system heat pump water heaters contain an outdoor component, noting that it manufactures a 120-volt heat pump water heater for indoor use only. Nyle suggested revising the definition to indicate that a split-system heat pump water heater means a heat pump-type water heater where the storage unit and heat pump components are independent from one another but must be connected to operate (*i.e.*, through refrigerant lines, water piping, or via a thermal storage device). (Nyle, No. 57 at p. 1)

In order to address the need for separate test conditions for split-system water heaters (see section III.C.7 of this document for a discussion on optional test conditions, which simulate different indoor and outdoor air conditions for the different components of a split-system water heater), DOE is adopting a definition for this subset of heat pump water heaters at 10 CFR part 430, subpart B, appendix E, section 1.14.

In response to these comments, DOE acknowledges that it is not necessary to specify the location of the components and/or the storage tank in the definition of “split-system heat pump water heater” as long as they are separate. Therefore, DOE has changed the definition of “split-system heat pump water heater” to mean a heat pump-type water heater in which at least the compressor, which may be installed outdoors, is separate from the storage tank. This definition still reflects that which is used in NEEA's Advanced Water Heating Specification (AWHS) version 8.0 (AWHS v8.0),³⁰ with minor modifications.

Additionally, a new definition for “circulating water heater” is being established in this final rule at 10 CFR 430.2, as discussed in section III.A.4.a of this document. This product category includes heat pump-only water heaters,

which is also discussed in section III.A.4.a of this document. Specific testing provisions for circulating water heaters are being newly established in this final rule, as discussed in section III.D.4 of this document.

b. Gas-Fired Heat Pump Storage Water Heaters

The statutory definition for a “heat pump type” water heater (*see* 42 U.S.C. 6291(27)(C)) is not specific to electric heat pump type water heaters. Gas-fired heat pump storage water heaters typically use an absorption or adsorption refrigeration cycle, driven by a gas burner, to transfer heat from the surrounding air to the water inside the water heater.

In the July 2014 Final Rule, DOE codified a definition for “gas-fired heat pump water heater” as follows:

Gas-fired heat pump water heater means a water heater that uses gas as the main energy source, has a nameplate input rating of 75,000 Btu/h (79 MJ/h) or less, has a maximum current rating of 24 amperes (including all auxiliary equipment such as fans, pumps, controls, and, if on the same circuit, any resistive elements) at an input voltage of no greater than 250 volts, has a rated storage volume not more than 120 gallons (450 liters), and is designed to transfer thermal energy from one temperature level to a higher temperature level to deliver water at a thermostatically controlled temperature less than or equal to 180 °F (82 °C). 79 FR 40542, 40567 (July 11, 2014).

Then, in the November 2016 Final Rule, DOE reasoned that even though gas-fired heat pump water heaters were covered by the existing test procedure, this definition was extraneous because it is not specifically referenced in any part of DOE's test procedures or energy conservation standards for consumer water heaters. 81 FR 79261, 79261, 79287 (Nov. 10, 2016). The definition for “gas-fired heat pump water heater” was deleted, and the current definition for “gas-fired storage water heater” was added instead. *Id.* at 81 FR 79320–79321.

Since the deletion of the definition in the November 2016 Final Rule, ASHRAE published an updated version of the test standard 118.2, “Method of Testing for Rating Residential Water Heaters and Residential-Duty Commercial Water Heaters,” in January 2022 (ASHRAE 118.2–2022) (*see* section III.B.2 for further discussion of this standard). The January 2022 NOPR issued prior to publication of ASHRAE 118.2–2022 and assessed public review drafts of ASHRAE 118.2–2022—all of which still included a definition for

²⁹ DOE reviewed public certification data in its Compliance Certification Management System (CCMS) database, found online at www.regulations.doe.gov/certification-data/#q=Product_Group_s%3A.

³⁰ AWHS v8.0 was published by NEEA on March 1, 2022. Although early editions of the AWHS focused primarily on providing more representative performance metrics for heat pump water heaters in cold climates, the latest editions are now more broadly focused on providing representative performance metrics for heat pump water heaters across all climates. AWHS v8.0 includes separate test condition requirements for integrated and split-system heat pump water heaters. These test conditions are discussed further in detail in section III.C.1 of this final rule. (Available at: nea.org/resources/advanced-water-heating-specification-v8.0) (Last accessed on Sept. 19, 2022).

“gas-fired heat pump storage water heater.” The definition for “gas-fired heat pump storage water heaters” in the public review drafts of ASHRAE 118.2–2022 was adopted in section 2.4 of the final published version, which defines the term as follows:

- (a) Use gas as the main energy source,
- (b) Have a nameplate input rating of 20,000 Btu/h (26.4 MJ/h) or less,
- (c) Have a maximum current rating of 24 amp (including all auxiliary equipment, such as fans, pumps, controls, and, if on the same circuit, any resistive elements) at an input voltage of no greater than 250 V,
- (d) Have a rated storage volume not more than 120 gal (450 L), and
- (e) Are designed to transfer thermal energy from one temperature level to a higher temperature level to deliver water at a thermostatically controlled temperature less than or equal to 180 °F (82 °C).

In the January 2022 NOPR, DOE stated that, currently, a water heater that uses gas as the main energy source, has a nameplate input rating of 75,000 Btu/h or less, and contains more than one gallon of water per 4,000 Btu per hour of input is a gas-fired storage water heater. (10 CFR 430.2) If the gas-fired storage water heater also has a heat pump with a maximum current rating of 24 amperes at a voltage no greater than 250 volts, is designed to transfer thermal energy from one temperature level to a higher temperature level for the purpose of heating water, including all ancillary equipment such as fans, storage tanks, pumps, or controls necessary for the device to perform its function, it would be a heat pump type unit (see 10 CFR 430.2). 87 FR 1554, 1564 (Jan. 11, 2022).

DOE also noted in the January 2022 NOPR that this industry definition establishes the scope of coverage for these products more narrowly than the current definitions for “gas-fired storage water heater” and “heat pump type” water heater together. Specifically, the ASHRAE 118.2–2022 definition limits the input rate at 20,000 Btu/h—presumably because the input rates of models currently in development for residential applications are less than 20,000 Btu/h—whereas the current definitions at 10 CFR 430.2 accommodate potential future products up to 75,000 Btu/h. In recognition of the developing market for gas-fired heat pump water heaters, DOE had tentatively determined not to limit scope of coverage to only 20,000 Btu/h. 87 FR 1554, 1564 (Jan. 11, 2022).

In response to the January 2022 NOPR, BWC suggested DOE re-evaluate whether current consumer water heater definitions adequately cover gas-fired

heat pump water heaters (as defined by ASHRAE) in light of questions as to whether features related to these products depart from the current consumer water heater definitions. (BWC, No. 33 at p. 2) However, the commenter did not provide further details.

DOE did not receive any additional comments elucidating which features may be of concern, and as a result, DOE is not able to identify reasons to justify redefining gas-fired heat pump storage water heaters in a way that departs from the current definitions. At the time of this final rule, such products are still mostly in the field trial stage in the United States, and, thus, they are not mass-produced, nor are they widely distributed in the commercial market. However, DOE is aware that products currently under development consist of a modulating gas-fired burner that powers an absorption cycle using a design which would meet the definition for a “split-system heat pump water heater” (discussed in section III.A.2.a of this document). Nonetheless, because the current definitions for “gas-fired storage water heater” and “heat pump type” water heater are sufficiently broad, such products would remain appropriately encompassed within the current scope of coverage. Should more designs of gas-fired heat pump water heaters (either storage type or instantaneous type) emerge into the water heaters market, DOE would evaluate the definitions and appropriateness of its test methods for gas-fired and heat pump products as they would apply to this novel technology.

Moreover, while ASHRAE 118.2–2022 does define gas-fired heat pump storage water heaters, there are no unique test methods for these products outlined in the industry test standards. Similar to the determination in the November 2016 Final Rule, DOE has concluded that the definition in ASHRAE 118.2–2022 is extraneous. Furthermore, given that no concrete concerns regarding the applicability of the current methods to gas-fired heat pump water heaters have been identified, DOE has determined not to adopt any specific provisions for these in its amended appendix E test procedure at this time.

3. Residential-Duty Commercial Water Heaters

In this rulemaking, DOE has sought comment on the definition for “residential-duty commercial water heater,” which defines a category of commercial water heaters that are subject to the appendix E test procedure

due to their residential applications. 85 FR 21104, 21108 (April 16, 2020).

In the January 2022 NOPR, DOE acknowledged that some water heaters intended for commercial use are covered by the residential-duty commercial water heater definition and tested and rated to the appendix E test procedure and residential-duty commercial water heater energy conservation standards in terms of UEF. DOE explained that these water heaters have characteristics that are similar to water heaters with residential applications and, as such, under 42 U.S.C. 6295(e)(5)(F), cannot be excluded from being tested and rated using the consumer water heaters test procedure and residential-duty commercial water heater energy conservation standards. Thus, DOE did not propose amendments to this definition. 87 FR 1554, 1566 (Jan. 11, 2022).

DOE has determined that whether a product is marketed as commercial or residential may not always be indicative of the intended installation location. The January 2022 NOPR provided the example of water heaters that are intended for residential use but sometimes marketed as “commercial-grade” as a means to convey an expectation of reliability. 87 FR 1554, 1566–1567 (Jan. 11, 2022).

In commenting on the January 2022 NOPR, with regards to residential-duty commercial water heaters, AET commented that the method used to evaluate consumer electric instantaneous and residential-duty commercial electric instantaneous water heaters in the December 2016 Conversion Factor Final Rule was not approved for these products, and the energy conservation standards DOE issued for consumer water heaters could not be met by them. AET argued that the energy conservation standards for residential-duty commercial electric instantaneous water heaters were based on performance for fossil fuel-fired commercial tankless water heaters as opposed to actual product testing, and, therefore, the commenter asserted that the minimum efficiency requirements for residential-duty commercial electric instantaneous water heaters are too low and should be updated. (AET, No. 29 at pp. 14–15)

DOE understands that the commenter’s discussion of the “method used to evaluate consumer electric instantaneous and residential-duty commercial electric instantaneous water heaters” refers to the analytical approach in 2016 that was used to predict the UEF values of these water heaters from existing representations of maximum GPM (see 81 FR 96204,

92616–92617 (Dec. 29, 2016)) and thermal efficiency (*see* 81 FR 96204, 96218 (Dec. 29, 2016)). At this time, however, the current appendix E test procedure does provide a method to test and rate these water heaters.³¹ DOE notes that there are currently consumer and residential-duty commercial electric instantaneous water heaters certified to meet the applicable energy conservation standards.

Otherwise, DOE did not receive any comments specifically pertaining to the definition for residential-duty commercial water heaters. Therefore, DOE is not amending the definition for “residential-duty commercial water heater” in this final rule for the reasons previously discussed. DOE may consider potential amended standards for residential-duty commercial electric instantaneous water heaters in a separate rulemaking addressing the energy conservation standards for commercial water heaters.³²

4. Specialty Water Heaters

As first proposed in the January 2022 NOPR, this final rule expands the scope of coverage of the appendix E test procedure to include low-temperature water heaters and circulating water heaters, which both fall under the statutory definition of consumer “water heater” but did not previously have test methods appropriate for their unique operation. DOE is also re-instating an inadvertently omitted definition for “tabletop water heater” at 10 CFR 430.2. In addition, DOE has considered whether to address solar water heaters in the consumer water heaters test procedure, but the Department has determined not to expand the scope of coverage of the appendix E to these products at this time. DOE may further consider solar water heaters in a separate rulemaking in the future. Each of these categories of water heaters is discussed in the following subsections.

Dyson generally commented that indirect circulation systems especially have an extraordinarily flexible use case and can be implemented in both warm and cool regions. (Dyson, No. 28 at p. 1) DOE understands this comment to refer to systems which use a separate boiler to provide the heat source for domestic water heating. However,

³¹ Section 5.3.2 of appendix E details the Max GPM rating test for flow-activated water heaters, Table II in section 5.4.1 of appendix E details how to select draw pattern based on Max GPM rating, and sections 5.4.2 and 5.4.3 of appendix E detail the test sequence.

³² DOE is concurrently evaluating energy conservation standards for commercial water heaters in Docket No. EERE–2021–BT–STD–0027.

consumer boilers are not within the scope of this rulemaking.

a. Circulating Water Heaters

As discussed in section III.A of this document, a gas-fired instantaneous water heater is a water heater that uses gas as the main energy source, has a nameplate input rating less than 200,000 Btu per hour, and contains no more than one gallon of water per 4,000 Btu per hour of input. 10 CFR 430.2.

In the April 2020 RFI, DOE requested feedback on the typical application of a specific configuration of gas-fired instantaneous water heaters, commonly referred to as “circulating gas-fired instantaneous water heaters.” 85 FR 21104, 21113 (April 16, 2020). As explained in the April 2020 RFI, DOE has found that several manufacturers produce consumer gas-fired instantaneous water heaters that are designed to be used with a volume of stored water (usually in a tank, but sometimes in a recirculating hot water system of sufficient volume, such as a hydronic space heating or designated hot water system) in which the water heater does not provide hot water directly to fixtures, such as a faucet or shower head, but rather replenishes heat lost from the tank or system through hot water draws or standby losses by circulating water to and from the tank or other system. These circulating gas-fired instantaneous water heaters are typically activated by an aquastat³³ installed in a storage tank that is sold separately or by an inlet water temperature sensor. DOE further stated that while the products identified by DOE are within the statutory and regulatory definition of a consumer “water heater” and, therefore, a covered product, the design and application of circulating gas-fired instantaneous water heaters make testing to the currently applicable Federal test procedure for consumer water heaters difficult, if not impossible, as these products are not capable of delivering water at the temperatures and flow rates specified in the UEF test method contained therein. *Id.* As a result, the currently applicable appendix E test procedure does not sufficiently cover circulating water heaters.

DOE received several comments on the April 2020 RFI recommending generally that DOE amend the regulatory definitions of gas-fired instantaneous water heaters to exclude models designed exclusively for commercial use even though they have

³³ An “aquastat” is a temperature measuring device typically used to control the water temperature in a separate hot water storage tank.

input rates below the consumer water heater input rate limit (*i.e.*, $\leq 200,000$ Btu/h). AHRI and individual manufacturers commented that these products are used in commercial applications even though they may in certain cases meet the statutory definition for a consumer water heater, and that the residential draw pattern profiles may not be applicable. These comments are discussed in detail in the January 2022 NOPR. 87 FR 1554, 1565 (Jan. 11, 2022).

In the January 2022 NOPR, DOE noted that 42 U.S.C. 6291(1) states that a “consumer product” means any article of a type which, to any significant extent, is distributed in commerce for personal use or consumption by individuals. DOE also stated that its examination of product literature has found that circulating water heaters are predominately marketed for commercial applications. However, the input rates of many of the available models are below the maximum input rate of a consumer water heater and can, therefore, be suitable for residential applications. DOE noted that there exist circulating heat pump water heaters (heat pump-only water heaters) which operate in the same manner as gas-fired circulating water heaters but are clearly marketed for residential applications. Consequently, it is foreseeable that there could be the potential for product substitution into the consumer market. For these reasons, DOE tentatively determined that circulating water heaters are covered “consumer products.” 87 FR 1554, 1565 (Jan. 11, 2022).

In the January 2022 NOPR, DOE proposed to include the following definition at 10 CFR 430.2: “*Circulating water heater* means an instantaneous or heat pump-type water heater that does not have an operational scheme in which the burner, heating element, or compressor initiates and/or terminates heating based on sensing flow; has a water temperature sensor located at the inlet of the water heater or in a separate storage tank that is the primary means of initiating and terminating heating; and must be used in combination with a recirculating pump and either a separate storage tank or water circulation loop in order to achieve the water flow and temperature conditions recommended in the manufacturer’s installation and operation instructions.” 87 FR 1554, 1565 (Jan. 11, 2022).

Commenters had varying viewpoints on this topic. AET expressed general agreement with DOE’s proposal to add a new definition and product category for circulating water heaters. (AET, No. 29 at p. 1)

Rheem supported the addition of a definition for “circulating water heater” to 10 CFR 430.2 and accompanying test procedures within appendix E for such products that have residential applications, but the commenter emphasized that the division between consumer and commercial water heaters should be appropriately set. Rheem argued that because a “circulating water heater” must use a separate storage tank, circulating water heater product classes should be defined using the storage-type unit input rate criteria (e.g., a gas-fired circulating water heater with an input rate at or below 75,000 Btu/h is a consumer water heater and greater than 75,000 Btu/h is a commercial water heater). Rheem also recommended further investigation as to whether certain capacities of storage-type water heaters could be covered by the “circulating water heater” definition. Rheem added that the “circulating water heater” definition should be amended to allow a water temperature sensor at the outlet of the water heater. (Rheem, No. 31 at p. 2)

BWC generally disagreed with DOE’s proposal that circulating water heaters should be covered as consumer products, arguing that these products are exclusively installed in commercial applications as either part of a recirculation loop or coupled to an unfired hot water storage tank. BWC also noted that circulating water heaters heat water to higher temperatures than consumer instantaneous water heaters do. BWC argued that classifying circulating water heaters as consumer products would provide little to no benefit to consumers, place additional burden on manufacturers, and cause market confusion as to how these products are specified and designed for field applications. (BWC, No. 33 at pp. 1–2)

AHRI expressed concerns about including circulating water heaters in a residential water heaters test procedure because they are mostly used in commercial applications, even with input rates below 200,000 Btu/h. In lieu of a solution in the test procedure, AHRI requested that DOE reinstate the enforcement policy on circulating water heaters.³⁴ (AHRI, No. 40 at p. 5) A.O. Smith provided similar comments, suggesting that DOE should reissue the September 5, 2019 enforcement policy for gas-fired circulating water heaters, or alternatively identify them in the test procedure as “historically regulated as commercial water heating equipment”

that “can be tested via the thermal efficiency energy metrics; and . . . therefore should not be subjected to UEF requirements.” (A.O. Smith, No. 37 at pp. 2–3) Like AHRI and A.O. Smith, BWC recommended reinstating the September 2019 enforcement policy to allow industry to determine the proper test procedure. (BWC, No. 33 at pp. 1–2)

EI requested more information on the size of the existing stock and current sales volumes of circulating water heaters. (EI, Jan. 27, 2022 Public Meeting Transcript, No. 27 at pp. 46–47)

In response, the Department reiterates that EPCA directed DOE to develop a test procedure that applies, to the maximum extent practicable, to all water heating technologies in use and to future water heating technologies. (42 U.S.C. 6295(e)(5)(H)) As a circulating water heater could be designed to operate in a similar manner to other consumer water heaters (i.e., “heat pump-only” water heaters) and at conditions appropriate for residential applications, DOE is required to address these products in appendix E with other classes of consumer water heaters. Furthermore, the definition for “consumer product” states that it is an article “of a type” that is distributed for personal use or consumption by individuals “without regard to whether such article of such type is in fact distributed in commerce for personal use or consumption by an individual.” (42 U.S.C. 6291(1))

In response to Rheem’s comment, circulating water heaters have high input rate to storage volume ratios, which classify these products as instantaneous-type water heaters (see 10 CFR 430.2 and 42 U.S.C. 6291(27)(B)). As such, the statutory definition of a storage-type water heater (found at 42 U.S.C. 6291(27)(A)) does not cover circulating water heaters because circulating water heaters have no more than one gallon of water per 4,000 Btu/h of input. As a result, the 75,000 Btu/h upper limit on the input rate for gas-fired storage-type water heaters would not apply and will not be included in the scope of the definition of “circulating water heater.”

In response to BWC’s comments, DOE notes that hot water delivery temperature is not related to the statutory definition of coverage. Rather, EPCA defines whether a water heater is covered as a consumer product primarily according to its input rating, without regard to its maximum hot water delivery temperature. DOE also concludes that classifying circulating water heaters (that meet the input rating requirements) as consumer products

would provide a benefit to consumers by allowing them to compare circulating water heaters alongside other consumer water heaters with a UEF rating. Under 42 U.S.C. 6293(b), EPCA requires that DOE test procedure not place undue burden on manufacturers. In this instance, although test burden would increase for manufacturers of circulating water heaters, it would not be considered an undue burden, because these water heaters are consumer products (by definition) and, therefore, should be subject to consumer water heater test procedures. Contrary to BWC’s assertion, DOE concludes that covering circulating water heaters as consumer products would reduce or resolve market confusion surrounding these products; since they can be used in residential applications, they should be rated accordingly.

In response to A.O. Smith’s comment requesting DOE to consider circulating gas-fired water heaters as historically regulated as commercial water heaters and sufficiently described by the commercial water heater metrics, DOE is not expanding the scope to products which are “historically regulated as commercial water heating equipment” because DOE is only considering circulating gas-fired water heaters with input rates less than or equal to 200,000 Btu/h, which meet the existing statutory definition for consumer water heaters (and, thus, do not meet the definition for gas-fired instantaneous commercial water heaters). Furthermore, DOE clarifies that the Department is not considering these gas-fired circulating water heaters (ones which meet the existing statutory definition for consumer water heaters) to be residential-duty commercial water heaters.

In response to the July 2022 SNOPIR, BWC and AHRI once again reiterated their understanding that circulating water heaters are used almost exclusively in commercial applications. (BWC, No. 48 at p.4; AHRI, No. 55 at p. 5) BWC requested that DOE exercise authority granted under the American Manufacturing Technical Corrections Act (AEMTCA) (42 U.S.C. 6295(e)(5)(F)) to regulate circulating water heaters as commercial products even though they meet residential definitions, or clearly demonstrate residential use. (BWC, No. 48 at p. 4) AHRI suggested that addressing circulating water heaters in a consumer rulemaking would cause confusion because their efficiency metric is different from conventional consumer water heaters. (AHRI, No. 55 at p. 5)

In response, EPCA allows DOE to provide an exclusion from the uniform

³⁴ DOE had issued an enforcement policy for circulating water heaters that expired on December 31, 2021.

efficiency descriptor for specific categories of otherwise covered water heaters that do not have residential uses, that can be clearly described, and that are effectively rated using the current thermal efficiency and standby loss descriptors. (42 U.S.C. 6295(e)(5)(F)(i))³⁵ However, DOE reads this statutory provision as only permitting exclusion of water heaters that were categories of covered *commercial* water heaters under section 342(a)(5) of EPCA [42 U.S.C. 6313(a)(5)]. It does not grant DOE authority to exclude consumer water heaters from the ambit of the uniform test procedure, nor to somehow convert consumer water heaters to commercial water heaters and to subject them to energy conservation standards applicable to commercial water heaters. In the present case, it is clear that the circulating water heaters in question are consumer water heaters, given that they have input rates below 200,000 Btu/h, and they otherwise meet the definitional criteria of the statute for an instantaneous-type water heater (*see* 42 U.S.C. 6291(27)(B)). Moreover, circulating water heaters have the demonstrated ability to perform tank loading or recirculating loop operation, as would indicate that these products do have clearly described residential uses. Consequently, in response to these comments, DOE notes that because both heat pump-only and gas-fired circulating water heaters meet the requirements to be classified as consumer products under EPCA, the statute requires that such water heaters must be tested according to DOE test procedure at appendix E.

This final rule establishes a test method to determine the UEF of consumer circulating water heaters. Effective and compliance dates are discussed further in section III.I of this document.

In development of this final rule, DOE was not able to discern rates of shipments and amount of stock for consumer circulating water heaters as EEI had requested. However, DOE did identify circulating water heater models currently on the market that are consumer water heaters. DOE has determined that circulating water heaters may have a water temperature

sensor at the inlet or at the outlet of the water heater—as suggested by Rheem—and, therefore, the Department agrees with Rheem and is adopting the following definition for “circulating water heater” at 10 CFR 430.2:

Circulating water heater means an instantaneous or heat pump-type water heater that does not have an operational scheme in which the burner, heating element, or compressor initiates and/or terminates heating based on sensing flow; has a water temperature sensor located at the inlet or at the outlet of the water heater or in a separate storage tank that is the primary means of initiating and terminating heating; and must be used in combination with a recirculating pump and either a separate storage tank or water circulation loop in order to achieve the water flow and temperature conditions recommended in the manufacturer’s installation and operation instructions.

b. Low-Temperature Water Heaters

DOE has identified certain flow-activated water heaters that are designed to deliver water at temperatures below the set point temperature of 125 °F ±5 °F (51.7 °C ±2.8 °C) that is required by section 2.5 of the currently applicable appendix E (hereinafter referred to as “low-temperature” water heaters). These low-temperature water heaters (often referred to as “handwashing” or “point-of-use” water heaters in marketing literature) typically have low heating rates, which requires the testing agency to reduce the flow rate in order to be able to achieve the outlet temperature within the set point temperature range. However, these units also have a minimum activation flow rate below which the unit shuts off. To the extent that a unit would stop heating water when the flow rate is too low, there may be no flow rate at which the unit would operate and deliver water at the outlet temperature required under section 2.5 of appendix E. Further, the definition of water heater or electric instantaneous water heater does not include a minimum water delivery temperature. To the extent that a low-temperature water heater uses electricity as the energy source, has a nameplate input rating of 12 kilowatts or less, and contains no more than one gallon of water per 4,000 Btu per hour of input, it would be an electric instantaneous water heater. 10 CFR 430.2. Therefore, because such products are within the scope of consumer water heater coverage under EPCA, the appendix E test procedure should address them; however, the currently applicable appendix E does not address them.

DOE requested information in the April 2020 RFI on testing these products at a lower set point temperature and other potential changes which may be necessary to accommodate these types of models. 85 FR 21104, 21113 (April 16, 2020). Several commenters on the April 2020 RFI recommended that the test procedure be modified to indicate a lower set point temperature for testing, such as the maximum water temperature delivery that the model is capable of delivering (see NOPR discussion for complete details). 87 FR 1554, 1582 (Jan. 11, 2022).

In the January 2022 NOPR, DOE proposed to define a “low-temperature water heater” as an electric instantaneous water heater that is not a circulating water heater and cannot deliver water at a temperature greater than or equal to the set point temperature specified in section 2.5 of appendix E to subpart B of this part when supplied with water at the supply water temperature specified in section 2.3 of appendix E to subpart B of this part. DOE also tentatively determined that lowering the set point temperature for low-temperature water heaters to their maximum possible delivery temperature would allow these water heaters to be tested appropriately and in a representative manner. As such, DOE proposed to require low-temperature water heaters to be tested to their maximum possible delivery temperature. 87 FR 1554, 1583 (Jan. 11, 2022).

AET agreed with DOE’s proposal to add a new definition and product category for low-temperature water heaters. (AET, No. 29 at p. 2) EEI requested more information on the size of the existing stock, as well as the current sales volumes of low-temperature water heaters. (EEI, Jan. 27, 2022 Public Meeting Transcript, No. 27 at pp. 46–47) As with circulating water heaters, DOE does not currently have this information available but will continue to gather this data to the extent possible.

Rheem commented that the proposed definition for “low-temperature water heater” should include water heaters with less than 10 gallons of storage and clarify how it is different from other electric water heaters. Rheem suggested that the installation and operation (I&O) manual could be referenced to determine delivery temperature limits, but alternatively, manufacturers could certify supplemental testing instructions to DOE (*i.e.*, when testing an electric instantaneous water heater set according to the I&O manual and cannot meet the required delivery temperature, the unit should be tested according to the

³⁵ DOE acted in accordance with EPCA provisions as specified at 6295(e)(5)(F)(i) when establishing product classes for residential-duty commercial water heaters. In a July 2014 Final Rule establishing the UEF test procedure, DOE determined that covered commercial water heating equipment that did not meet the definition of a “residential-duty commercial water heater” met the criteria in EPCA for exclusion from the uniform efficiency descriptor. 79 FR 40542, 40545–40547 (July 11, 2014).

maximum delivery temperature). (Rheem, No. 31 at p. 3)

In response to the comments from Rheem, DOE notes that the inability to deliver water at the specified outlet water temperatures in appendix E is independent of the storage volume of the water heater. Hence, restricting this product type definition to only those water heaters that have less than 10 gallons of storage volume may unintentionally leave larger low-temperature water heaters without adequate test provisions in appendix E. This inability to deliver water at 125 °F ±5 °F—*specifically at the appendix E flow rate*—serves as the key distinguishing factor between low-temperature water heaters and other electric instantaneous water heaters. While the maximum delivery temperatures may be noted in an I&O manual, as Rheem suggested, this must be verified under the test conditions (most notably the supply water temperatures) specified in appendix E. Section 5.2.2 of the amended appendix E includes instructions for setting the outlet discharge temperature. Should the flow rate need to be reduced in order to meet the outlet temperature requirements, then the product would meet the criterion for a low-temperature water heater.

In this final rule, DOE is adopting a slightly modified definition for “low-temperature water heater,” taking into account the comments provided by Rheem. Accordingly, DOE is defining “low-temperature water heater” as an electric instantaneous water heater that is not a circulating water heater and cannot deliver water at a temperature greater than or equal to the set point temperature specified in section 2.5 of appendix E when supplied with water at the supply water temperature specified in section 2.3 of appendix E at the flow rate specified in section 5.2.2.1 of appendix E. (DOE is including language which specifies that the delivery temperature is that which results from the appendix E flow rate.)

c. Tabletop Water Heaters

As discussed in the January 2022 NOPR, the definition for “tabletop water heater” was removed from appendix E as part of the July 2014 Final Rule but was inadvertently not added to 10 CFR 430.2 (79 FR 40542, 40567–40568 (July 14, 2014)). 87 FR 1554, 1566 (Jan. 11, 2022). Up until then, “tabletop water heater” was defined as a water heater in a rectangular box enclosure designed to slide into a kitchen countertop space with typical dimensions of 36 inches high, 25 inches deep, and 24 inches wide. 66 FR 4474, 4497 (Jan. 17, 2001).

In the January 2022 NOPR, after considering comments on the April 2020 RFI, DOE proposed to add the definition of tabletop water heater 10 CFR 430.2, as it read prior to being removed from appendix E. 87 FR 1554, 1556.

In response to the January 2022 NOPR, AET agreed with re-instating the definition for tabletop water heater at 10 CFR 430.2. (AET, No. 29 at p. 2)

DOE did not receive any other comment relating to this proposal, so the Department is re-instating the definition for “tabletop water heater” at 10 CFR 430.2, as proposed.

d. Solar Water Heaters

In response to an RFI published on May 21, 2020 (May 2020 RFI), regarding the energy conservation standards for consumer water heaters (85 FR 30853), the Solar Rating & Certification Corporation (SRCC) recommended that solar water heating technologies be considered for inclusion in the energy conservation standards and test procedures for consumer water heaters. SRCC stated that without the involvement of DOE, the industry metrics struggle to gain acceptance with policymakers and consumers. SRCC also stated that DOE rulemakings to include solar-equipped water heaters in regulations would serve to establish a single performance metric and signal the legitimacy of solar water heating technologies. (Docket: EERE–2017–BT–STD–0019, SRCC, No. 11 at pp. 3–4)

Subsequently, on October 7, 2020, SRCC published a draft test procedure titled, “Solar Uniform Energy Factor Procedure for Solar Water Heating Systems” (SUEF test method).³⁶ The draft SRCC test procedure addresses methods to test different types of solar water heaters.

In the January 2022 NOPR, DOE responded to SRCC’s comment on the May 2020 RFI, by noting that on April 8, 2015, DOE published an energy conservation standards NOPR (the April 2015 NOPR) addressing definitions for consumer water heaters (80 FR 18784). 87 FR 1554, 1585 (Jan. 11, 2022). DOE further noted that the April 2015 NOPR proposed definitions for “solar-assisted fossil fuel storage water heater” and “solar-assisted electric storage water heater” and clarified that water heaters meeting these definitions are not subject to the amended energy conservation standards for consumer water heaters

³⁶ SRCC’s draft Solar Uniform Energy Factor Procedure for Solar Water Heating Systems is available at: www.iccsafe.org/wp-content/uploads/is_stsc/Solar-UEF-Specification-for-Rating-Solar-Water-Heating-Systems-20201012.pdf (Last accessed on July 13, 2022).

established by the April 2010 final rule. *Id.* DOE stated its intention to address solar water heaters in a separate rulemaking. *Id.* In response to the January 2022 NOPR, SEA commented that DOE should account for solar water heaters in its test procedure and energy conservation standards. (SEA, No. 24 at p. 1)

In response, DOE notes that “solar water heater,” as defined in section 5.1 of SRCC’s SUEF test method, include a solar collector or module that is directly exposed to solar radiation outdoors and is often separated from a storage tank and/or back-up water heater located indoors. Therefore, appendix E does not currently accommodate these products, and an in-depth evaluation of the modifications to appendix E necessary to accommodate the testing of these products is required. Given the lack of available test data utilizing the SUEF test method, DOE is not amending the scope of the appendix E test procedure in this rulemaking to explicitly include solar water heaters at this time. However, DOE will continue to consider these solar water heater products further, and depending upon the conclusions reached, the Department may address them in a separate future rulemaking, as appropriate.

B. Updates to Industry Standards

Prior to the effective date of this final rule, the applicable DOE test procedure in appendix E referenced the following industry standards:

- ASHRAE 41.1–1986 (Reaffirmed 2006), Standard Method for Temperature Measurement (ASHRAE 41.1–1986 (RA 2006)); and
- ASTM D2156–09, (ASTM D2156–09), Standard Test Method for Smoke Density in Flue Gases from Burning Distillate Fuels.

ASHRAE 41.1–1986 (RA 2006) was superseded by ASHRAE 41.1–2013 on January 30, 2013 (ASHRAE 41.1–2013). ASHRAE 41.1–2013 was superseded by ASHRAE 41.1–2020 on June 30, 2020. Updates to ASHRAE 41.1 are discussed in section III.B.1 of this document.

ASTM D2156–09 was reapproved without modification in 2018 (ASTM D2156–09 (RA 2018)). In the January 2022 NOPR, DOE proposed to update appendix E to reference the most recent version of ASTM D2156 (*i.e.*, ASTM D2156–09 (RA 2018)). 87 FR 1554, 1567 (Jan. 11, 2022). DOE did not receive any comments in response to its proposal. Therefore, DOE is updating the reference of ASTM D2156–09 to the most recent industry standard (*i.e.*, ASTM D2156–09 (RA 2018)). DOE is also incorporating by reference ASTM E97–1987 (W1991) because it is

necessary to perform procedures within ASTM D2156–09 and ASTM D2156–09 (RA 2018).³⁷

As discussed previously in this document, ASHRAE maintains a water heater test procedure, ANSI/ASHRAE Standard 118.2, “Method of Testing for Rating Residential Water Heaters.” The test procedure specified in ANSI/ASHRAE 118.2–2006 (RA 2015) is similar to the DOE test procedure that was in effect prior to the July 2014 final rule, although neither the previous DOE consumer water heater test procedure nor the version in place prior to this final rule reference ANSI/ASHRAE Standard 118.2–2006 (RA 2015). In March 2019, ASHRAE published the March 2019 ASHRAE Draft 118.2, the second public review draft of Board of Standards Review (BSR) ANSI/ASHRAE Standard 118.2–2006R, “Method of Testing for Rating Residential Water Heaters and Residential-Duty Commercial Water Heaters,” which DOE referenced in the April 2020 RFI. 85 FR 21104, 21109–21111 (April 16, 2020). In April 2021, ASHRAE published substantive changes to a previous public review draft³⁸ of BSR ANSI/ASHRAE Standard 118.2–2006R, “Method of Testing for Rating Residential Water Heaters and Residential-Duty Commercial Water Heaters” (April 2021 ASHRAE Draft 118.2). The January 2022 NOPR examined these public review drafts and discussed the differences between them and the DOE test procedure. 87 FR 1554, 1567 (Jan. 11, 2022).

On January 24, 2022, ASHRAE published a revised edition of the 118.2 standard, “Method of Testing for Rating Residential Water Heaters and Residential-Duty Commercial Water Heaters,” ASHRAE 118.2–2022. The published edition finalized revisions shown in the March 2019 and April 2021 public review drafts.

In comments responding to the January 2022 NOPR, Lutz encouraged DOE to incorporate by reference the industry test standard ASHRAE 118.2–2022. Lutz also recommended DOE review the test procedures in use in

Europe and Japan. (Lutz, No. 35 at p. 1) BWC supported DOE’s proposal to incorporate by reference the latest industry test standards. (BWC, No. 33 at p. 2)

As discussed previously in this document, DOE will adopt industry test standards as DOE test procedures for covered products and equipment, unless such methodology would be unduly burdensome to conduct or would not produce test results that reflect the energy efficiency, energy use, water use (as specified in EPCA) or estimated operating costs of that equipment during a representative average use cycle. (10 CFR part 430, subpart C, appendix A, section 8(c)) In this final rule, DOE is harmonizing provisions in appendix E to align with certain updates in ASHRAE 118.2–2022 rather than incorporate the entire industry test standard. DOE has concluded that certain updates in ASHRAE 118.2–2022 do not meet the EPCA criteria outlined in this paragraph and has, thus, determined that those updates should not be incorporated into the DOE test procedure at appendix E. DOE’s assessment of ASHRAE 118.2–2022 is laid out in detail in section III.B.2 of this document.

Finally, as discussed in the July 2022 SNOPIR, DOE has reviewed NEEA’s Advanced Water Heating Specifications in order to assess optional rating conditions and methods for heat pump water heaters. This test procedure was identified by stakeholders in response to the January 2022 NOPR as becoming a widely used methodology to provide alternate ratings for heat pump water heaters at different climate conditions. 87 FR 42270, 42275–42276 (July 14, 2022). In the January 2022 NOPR, DOE discussed comments previously received on the April 2020 RFI suggesting that DOE explore the usage of NEEA’s Advanced Water Heating Specification—which was at version 7.0 at the time—for voluntary climate-specific efficiency representations of heat pump water heaters. 87 FR 1554, 1580 (Jan. 11, 2022). In response to those comments, DOE stated that it did not have data to indicate what conditions would be representative for regional representations, and, thus, DOE tentatively determined not to allow optional representations of additional efficiency ratings at test conditions other than those found in the DOE test procedure (which are representative of the Nation as a whole), such as those made in accordance with NEEA’s Advanced Water Heating Specification. *Id.* However, as discussed in the July 2022 SNOPIR, DOE has re-evaluated the benefits to consumers provided by

optional representations. 87 FR 42270, 42275–42277 (July 14, 2022). In this final rule, DOE is including optional test conditions for heat pump water heaters aligning with version 8.0 (the latest version) of NEEA’s Advanced Water Heating Specification. This matter is discussed in further detail in section III.C.7 of this document.

1. ASHRAE 41.1–2020

As stated previously, ASHRAE 41.1–1986 (RA 2006) was superseded by ASHRAE 41.1–2013, and ASHRAE 41.1–2013 was superseded by ASHRAE 41.1–2020. ASHRAE 41.1–2013 removed the aspirated wet-bulb psychrometer descriptions and stated they would be included in the next revision to ASHRAE 41.6, “Standard Method for Humidity Measurement.” ASHRAE 41.6 was updated on July 3, 2014, and included the aspirated wet-bulb psychrometer descriptions that were removed in ASHRAE 41.1–2013. ASHRAE 41.1–2013 also added uncertainty analysis for temperature measurements, information for thermistor-type devices, descriptions for thermopiles, and reorganized the standard to be consistent with other ASHRAE standards. ASHRAE 41.1–2020 added conditional steady-state test criteria and further updated the standard to meet ASHRAE’s mandatory language requirements.

As discussed in the January 2022 NOPR, section 3.2.1 of appendix E requires that temperature measurements be made in accordance with ASHRAE 41.1–1986 (RA 2006), and section 3.2.2 of appendix E provides accuracy and precision requirements for air dry-bulb, air wet-bulb, inlet and outlet water, and storage tank temperatures. Sections 5.2.2.1 and 5.3.2 of appendix E effectively require steady-state operation in which the flow-activated water heater is operating at the maximum input rate, is supplied with water at a temperature of 58 °F ± 2 °F, and delivers water at a temperature of 125 °F ± 5 °F. 87 FR 1554, 1567 (Jan. 11, 2022).

In the development of this final rule, DOE reviewed ASHRAE 41.1–1986 (RA 2006), ASHRAE 41.1–2013, and ASHRAE 41.1–2020 and found that the sections most relevant to appendix E are the temperature measurement sections (*i.e.*, sections 5 through 11 of ASHRAE 41.1–1986 (RA 2006), section 7 of ASHRAE 41.1–2013, and section 7 of ASHRAE 41.1–2020)³⁹ and the steady-state test criteria added in ASHRAE 41.1–2020. The information in the

³⁷ Certain methods provided as part of ASTM E97–1987 (W1991) are directly referenced by ASTM D2156–09 and ASTM D2156–09 (RA 2018). Copies of ASTM E97–1987 (W1991) are readily available from ASTM International, 100 Barr Harbor Drive, P.O. Box C700, West Conshohocken, PA 19428–2959 or online at: www.astm.org. (Last accessed on Sept. 20, 2022.)

³⁸ The April 2021 ASHRAE Draft 118.2 shows only the proposed substantive changes to the March 2019 ASHRAE Draft 118.2. All sections not included in the April 2021 ASHRAE Draft 118.2 are as proposed in the March 2019 ASHRAE Draft 118.2 or have not been changed in a way that their content affects the results of the test procedure proposed in the March 2019 ASHRAE Draft 118.2.

³⁹ Sections 5 through 11 of ASHRAE 41.1–1986 (RA 2006) were combined into section 7 of ASHRAE 41.1–2013.

temperature measurement sections of the examined three versions of ASHRAE 41.1 does not vary significantly. The additional steady-state test criteria of ASHRAE 41.1–2020 varies significantly from and is more stringent than⁴⁰ the criteria specified in sections 5.2.2.1 and 5.3.2 of appendix E; however, the appendix E criteria supersede those in ASHRAE 41.1–2020.

In the January 2022 NOPR, DOE tentatively determined that updating the reference of ASHRAE 41.1–1986 (RA 2006) to the most recent version of the industry standard (*i.e.*, ASHRAE 41.1–2020) would not have a significant effect on the test results, as the content of the relevant sections of the ASHRAE 41.1 standards have not changed significantly and the new content published in ASHRAE 41.1–2020 is superseded by appendix E. As such, DOE proposed to update the reference of ASHRAE 41.1–1986 (RA 2006) to ASHRAE 41.1–2020. ASHRAE 41.1–2020 references ASHRAE 41.6–2014 and requires its use when measuring the wet-bulb temperature. The wet-bulb temperature is required when testing heat pump water heaters to appendix E, and, therefore, DOE also proposed to incorporate by reference ASHRAE 41.6–2014. 87 FR 1554, 1567–1568 (Jan. 11, 2022).

DOE did not receive any comments in response to its proposals to incorporate by reference ASHRAE 41.1–2020 and ASHRAE 41.6–2014; therefore, DOE is incorporating by reference both standards in this final rule for the reasons previously stated.

2. ASHRAE 118.2–2022

ASHRAE 118.2–2022, published on January 24, 2022 and approved by ANSI on March 1, 2022, supersedes ASHRAE 118.2–2006. The foreword to ASHRAE 118.2–2022 states that it was derived from the DOE appendix E test procedure but also has several substantive changes. Specifically, it notes that a major change was to move the conditions of the test (air temperature, humidity, inlet and outlet water temperatures) and draw patterns to an Informative Appendix A, “U.S. Values for Test Variables,” indicating that this test standard has been revised such that it can easily be applied with other test conditions and draw patterns. Additionally, the

⁴⁰ Section 5.5.3 of ASHRAE 41.1–2020 would be used to determine steady-state operation within sections 5.2.2.1 and 5.3.2 of appendix E. Using this criteria, a flow-activated water heater delivering water between 120 °F and 121 °F, which is within the current delivery temperature range of 125 °F ± 5 °F, would not be considered in steady-state due to the difference in temperature between the average of the sample and the set point temperature.

foreword states that other changes include clarifying the timing of the standby period, clarifying the end of the recovery period, specifying that the density of water used in calculations be measured at the outlet, and adjusting the FHR flow rate for smaller tanks and defining a draw time limit if the water heater can keep up with the FHR flow rate. The following subsections of this final rule discuss the substantial differences between the updated ASHRAE 118.2–2022 test standard and DOE’s existing appendix E test procedure. Based on a review of its own test data and stakeholder feedback, the Department is not adopting every update in ASHRAE 118.2–2022 into the amended appendix E test procedure promulgated by this final rule. DOE has provided discussion of the amendments being made to harmonize with ASHRAE 118.2–2022 in section III.B.2.b of this document, whereas other updates in ASHRAE 118.2–2022 not being adopted are discussed in section III.B.2.c of this document.

AET generally supported DOE’s proposal to adopt most aspects of ASHRAE 118.2 but noted that the definition of “UEF” in ASHRAE 118.2 is different from the definition of that term used by DOE. AET noted that a UEF rating per ASHRAE Standard 118.2 would not be comparable to a UEF rating per DOE’s test procedure due to differences in test conditions. (AET, No. 29 at pp. 6–7) DOE agrees that there could be differences between the UEF test result from ASHRAE 118.2–2022 and the amended appendix E test procedure from this final rule. Where differences between these test procedures exist, the requirements at 10 CFR 430.23 and appendix E control. As such, manufacturers must ensure that any representations of “UEF” are made in accordance with the applicable version of the DOE test procedure.

a. Scope

Section 2 of ASHRAE 118.2–2022 states that the industry test standard applies to water heaters designed to be capable of providing outlet water at a controlled temperature of at least the nominal outlet water temperature under the conditions specified in the standard. As discussed in section III.A.4.b of this final rule, the January 2022 NOPR proposed to expand the scope of the DOE test procedure to include low-temperature water heaters. 87 FR 1554, 1582–1583 (Jan. 11, 2022). As such, the scope of ASHRAE 118.2–2022 is narrower than the test procedure proposed in DOE’s January 2022 NOPR and July 2022 SNOPIR because it explicitly excludes low-temperature

water heaters. In order to include low-temperature water heaters within the scope of the amended appendix E test procedure, DOE is including testing provisions which are not in ASHRAE 118.2–2022 to allow for the testing of low-temperature water heaters. These test methods are discussed in section III.E.3 of this final rule.

Additionally, the scope of ASHRAE 118.2–2022 differs significantly from the scope of products covered under the EPCA definition for consumer “water heater” and DOE’s definition for “residential-duty commercial water heater.” For example, section 2 of ASHRAE 118.2–2022 limits the storage volume for storage-type water heaters to 120 gallons or less and limits the maximum delivery temperature to 180 °F (82 °C), whereas EPCA does not place limits on storage volume or maximum delivery temperature for consumer water heaters. (42 U.S.C. 6291(27); 42 U.S.C. 6311(12)(A)–(B)) The scope of electric instantaneous water heaters covered by ASHRAE 118.2–2022 equates to the limit for residential-duty commercial electric instantaneous water heaters; however, section 2.2 of ASHRAE 118.2–2022 does not specify any limits on storage volume, and as a result, it covers certain commercial electric instantaneous water heaters—whereas the currently applicable appendix E test procedure does not. Section 2.1 of ASHRAE 118.2–2022 has a definition for “electric heat-pump storage water heater” which explicitly limits the nameplate input rating to 12 kilowatts or less, which, as discussed in section III.A.2.a of this final rule, does not correspond to the statutory limit for heat pump-type units and would include commercial heat pump water heaters (which are outside of the scope of the appendix E test procedure). Finally, section 2.4 of ASHRAE 118.2–2022 limits gas-fired heat pump storage water heaters to nameplate input ratings no greater than 20,000 Btu/h, which is significantly lower than the statutory limit of 75,000 Btu/h (*see* 42 U.S.C. 6291(27)(A) and the discussion in section III.A.2.b of this document).

In the January 2022 NOPR, DOE evaluated feedback from commenters indicating that most aspects of the test methods in ASHRAE 118.2–2022⁴¹ were still applicable outside of its formal scope of coverage. 87 FR 1554, 1568 (Jan. 11, 2022). In the January 2022

⁴¹ ASHRAE 118.2–2022 was published on January 24, 2022, which was after the January 2022 NOPR was published in the *Federal Register* on January 11, 2022; thus, the NOPR only discusses public review drafts of ASHRAE 118.2–2022 which were available at the time.

NOPR, DOE stated that it has found through testing that models with rated storage volumes above 120 gallons or that can deliver water above 180 °F can be tested to DOE's appendix E test procedure, and, given the similarities between the currently applicable DOE test procedure and ASHRAE 118.2–2022, DOE tentatively determined that such models could also be tested using the methods in the ASHRAE test standard. *Id.* DOE did not receive any comments in response to this tentative conclusion in the January 2022 NOPR. Therefore, in evaluating the provisions within ASHRAE 118.2–2022, DOE has determined that its test methods remain applicable to all consumer water heaters and residential-duty commercial water heaters within the scope of appendix E (with the exception of low-temperature water heaters). As proposed in the January 2022 NOPR, this final rule makes several amendments to appendix E to harmonize with new provisions in ASHRAE 118.2–2022. Additionally, DOE determined that methods specified in annex B of ASHRAE 118.2 were applicable to the associated test procedures of this rulemaking, and, therefore, the Department has incorporated by reference ASHRAE 118.2–2022 for use in appendix E, with annex B being the directly applicable provision.

b. Provisions in ASHRAE 118.2–2022 Being Addressed by DOE

Thermal Break

ASHRAE 118.2–2022 specifies the use of a “thermal break” in the test set-ups shown for free-standing water heaters and water heaters supplied with a countertop enclosure (*see* Figures 1, 2, 3, 6, 7, 8, and 9 of ASHRAE 118.2–2022). A thermal break is optional in the ASHRAE 118.2–2022 test set-ups shown for wall-mounted water heaters (*see* Figures 4 and 5 of ASHRAE 118.2–2022).

ASHRAE 118.2–2022 defines a “thermal break” in section 3 as a nipple made of material that has thermal insulation properties (*e.g.* plastics) to insulate the bypass loop from the inlet piping. It should be able to withstand a pressure of 150 psi (1.034 MPa), and a temperature greater than the maximum temperature the water heater is designed to produce. A thermal break is added to the test set-up to prevent heat from traveling up the inlet piping into a bypass line, if one is utilized. (ASHRAE 118.2–2022 requires a bypass line to be installed, whereas the existing appendix E test procedure does not.) When purging the inlet piping before a draw, any heat that is transferred from the

water heater through the inlet piping to the bypass line section would be lost, as the bypass line is replenished with cold supply water. The thermal break helps to prevent this heat loss.

In this rulemaking, DOE has sought feedback from stakeholders in the April 2020 RFI as to whether a thermal break should be required in the DOE test procedure regardless of whether a bypass line is used, and additionally, whether DOE should adopt a definition for this set-up component. 85 FR 21104, 21110 (April 16, 2020). The January 2022 NOPR discussed the mixed comments received on this topic. In summary, three commenters stated that a thermal break should be included in the test set-up regardless of whether there is a bypass or purge line; however, three others (including a testing standards organization, CSA Group) stated that a thermal break is not needed if no bypass or purge loop is present. Several commenters indicated that a standardized definition for a “thermal break” would be beneficial for repeatability of the test procedure. 87 FR 1554, 1569 (Jan. 11, 2022).

In the January 2022 NOPR, DOE explained that a bypass line is a method that test laboratories use to ensure inlet water temperatures are within the bounds of the test procedure (*i.e.*, within 58 °F ±2 °F by the first measurement of the draw), but its inclusion in the test set-up can create a condition whereby a constant low temperature can remove energy from the water heater at a higher rate than would be removed in the field. Because a bypass line is not the only approach to maintaining inlet conditions, DOE had tentatively determined that requiring a thermal break (and providing a definition for this component) would not be necessary. *Id.*

BWC responded by indicating that it is not aware of any manufacturer or test laboratory omitting the use of a thermal break, and, therefore, DOE should adopt a definition for “thermal break” to ensure consistent results from laboratory to laboratory. The commenter recommended that a thermal break should be defined as “a plastic and thermally non-conductive material that can withstand a minimum temperature of 150 °F.” BWC also stated that its testing indicated that when a bypass line (also known as a “purge loop”) is used, all temperatures more consistently met the tolerance criteria in appendix E; furthermore, test results were more often out of tolerance when a bypass line was not used. BWC argued that as a result, use of a bypass line will remain common practice, and as such, thermal

breaks will also continue to be used. (BWC, No. 33 at p. 3)

DOE has considered the comments received on this topic throughout this rulemaking, and, although DOE maintains that a thermal break would not be needed in all set-up cases, the Department has concluded that there is overwhelming support for establishing a standardized definition for “thermal break.” In order to address concerns regarding the repeatability of the test procedure (*i.e.*, various facilities maintaining a consistent set-up approach), DOE is adopting a definition for this component consistent with that in section 3 of ASHRAE 118.2–2022, but with minor modification. Specifically, DOE is defining “thermal break” as “a thermally non-conductive material that can withstand a pressure of 150 psi (1.034 MPa) at a temperature greater than the maximum temperature the water heater is designed to produce and is utilized to insulate a bypass loop, if one is used in the test set-up, from the inlet piping.” However, DOE is not requiring the use of a bypass loop or a thermal break in this final rule. DOE reasons that providing a definition for a thermal break will improve consistency in test set-ups when the testing agency opts to use a bypass loop with a thermal break.

FHR Test Flow Rates

Section 7.3.3.1 of ASHRAE 118.2–2022 indicates that the flow rate for non-flow-activated water heaters with rated storage volumes less than 20 gallons would be 1.5 ± 0.25 gallons per minute (gpm) (5.7 ± 0.95 liters (L)/minute (min)) when conducting the FHR test. Section 5.3.3, “First-Hour Rating Test,” of appendix E requires that water heaters with a storage volume less than 20 gallons be tested at 1.0 ± 0.25 gpm (3.8 ± 0.95 L/min). These flow rates are lower than the 3.0 ± 0.25 gpm (11.4 ± 0.95 L/min) required for water heaters with rated storage volumes greater than or equal to 20 gallons. Water heaters with low rated storage volumes (less than 20 gallons) and high input rates can potentially operate indefinitely (*i.e.*, instantaneously) at even the 3.0 ± 0.25 gpm (11.4 ± 0.95 L/min) flow rate. Therefore, when such products are tested as currently required by appendix E, the measured FHR is near the maximum possible value of 60 gallons (227 L)⁴² and, as a result, these

⁴² At 1.0 ± 0.25 gallons per minute during the 60-minute first-hour rating test, the maximum possible delivery capacity is 1.0 gallon per minute × 60 minutes = 60 gallons. At 1.5 ± 0.25 gallons per minute during the 60-minute first-hour rating test, the maximum possible delivery capacity is 1.5 gallon per minute × 60 minutes = 90 gallons.

products would be required to use the medium draw pattern according to Table I of appendix E. However, as discussed in the January 2022 NOPR, these models could be used in applications similar to water heaters that are required to test using the high draw pattern, and the existing method of testing these products may not best represent how they are used in the field. Instead, DOE finds that a flow rate of 1.5 ± 0.25 gpm (5.7 ± 0.95 L/min)—as introduced in ASHRAE 118.2–2022—would be sufficient to allow these products to be tested and rated in the high draw pattern. 87 FR 1554, 1569–1570 (Jan. 11, 2022).

In this rulemaking, DOE has sought information from commenters regarding the flow rate for the FHR test of non-flow-activated water heaters with rated storage volumes less than 20 gallons. DOE has also participated in the public review of ASHRAE 118.2 prior to the 2022 edition being released, leading up to the establishment of the 1.5 ± 0.25 gpm (5.7 ± 0.95 L/min) flow rate criteria for these products during the FHR test. DOE also performed testing on three electric storage water heaters less than 20 gallons to both the then currently applicable appendix E and ASHRAE 118.2–2022 flow rates and provided these test data in the January 2022 NOPR. The results indicated that changing the flow rate during the FHR test for water heaters with a rated storage volume less than 20 gallons from 1.0 ± 0.25 gpm (3.8 ± 0.95L/min) to 1.5

± 0.25 gpm (5.7 ± 0.95 L/min) would have a relatively minimal impact on the FHR for water heaters with low input rates. For models with high input rates, the change in flow rate could significantly increase the FHR and result in some models being tested and rated for UEF using a higher draw pattern, which would provide ratings that are more representative of their actual use. Therefore, DOE proposed to adopt the higher flow rate of 1.5 ± 0.25 gpm (5.7 ± 0.95 L/min) for the FHR test of non-flow-activated water heaters with rated storage volumes less than 20 gallons. 87 FR 1554, 1570 (Jan. 11, 2022).

In response, AHRI indicated that the revised flow rate of 1.5 gpm may not be appropriate for models as small as 2 gallons, for which the proposed change could yield unrepresentative results for FHR. (AHRI, No. 40 at p. 4) AHRI also raised concerns about the accuracy of flow rates for smaller capacity water heaters. (AHRI, Jan. 27, 2022 Public Meeting Transcript, No. 27 at p. 41) Rheem generally supported DOE’s proposal to align with ASHRAE 118.2–2022 on this issue. However, Rheem pointed out that the test data provided in the NOPR reflected consumer water heaters in only the very small draw pattern, so Rheem requested DOE to provide further test data and also to conduct testing on products near the division between the very small and low draw patterns. Rheem stated that a change in draw pattern will affect the

UEF rating and will need to be taken into account. (Rheem, No. 31 at p. 2)

In response to the concerns raised by AHRI, DOE notes that its test data presented in the January 2022 NOPR were taken from samples in the very small draw pattern (see 87 FR 1554, 1570 (Jan. 11, 2022)). DOE has additionally provided the storage volumes of the products which were tested in Table III.1 of this final rule. The samples were all approximately 2 gallons in storage volume, and the 1.5 gpm flow rate was found to be sufficiently representative for these products (the absolute value of the largest percent difference was less than 5 percent). Additionally, as stated in the January 2022 NOPR, the increase in flow rate did not cause any of these products to move from the very small draw pattern to the low draw pattern, which resolves a chief concern regarding the representativeness of the FHR results. *Id.* In response to Rheem’s requests for additional data, DOE was not able to identify non-flow-activated water heaters less than 20 gallons closer to 18 gallons of FHR—the division between the very small and low draw patterns—in order to perform testing on such products. However, while the net average change may approximately be a 2-percent increase in FHR rating, DOE has determined that the increased flow rate will allow products to be rated in more representative draw patterns, as discussed earlier in this section.

TABLE III.1—AVERAGE FIRST-HOUR RATING BASED ON A FLOW RATE OF 1.0 GPM AND 1.5 GPM

Unit No.	Measured storage volume, gallons	Average FHR* at 1.0 gpm (3.8 L/min), gallons	Average FHR* at 1.5 gpm (5.7 L/min), gallons	Change %
1	2.4	7.3 (Very Small)	7.5 (Very Small)	+3.4
2	2.4	6.4 (Very Small)	6.2 (Very Small)	-2.2
3	1.8	6.9 (Very Small)	7.2 (Very Small)	+4.7
Net Average	+2.0.	

* FHR results are rounded to the nearest 0.1 gallon and reflect the arithmetic mean of four trials per water heater.

In this final rule, DOE is amending section 5.3.3.1 of the appendix E test procedure to require a flow rate of 1.5 ± 0.25 gpm (5.7 ± 0.95 L/min) when conducting the FHR test on non-flow-activated water heaters with rated storage volumes less than 20 gallons. 24-Hour Simulated-Use Test First Recovery Period

The first recovery period of the 24-hour simulated-use test is used in section 8.3.2 of ASHRAE 118.2–2022 and section 6.3.2 of appendix E to calculate recovery efficiency. Section 8.3.2 of ASHRAE 118.2–2022 specifies

that, when the first recovery of the 24-hour simulated-use test ends during a draw, the first recovery period extends until the end of that draw, whereas DOE’s test procedure does not explicitly address how to calculate recovery efficiency if the first recovery period ends during a draw.

A “recovery period” is defined in section 1 of appendix E as “the time when the main burner of a storage water heater is raising the temperature of the stored water.” Each of the parameters in the current recovery efficiency equation in section 6.3.2 of appendix E is

recorded from the “beginning of the test to the end of the first recovery period following the first draw.” The currently applicable appendix E test procedure does not explicitly state whether values are recorded at the end of the recovery period that ends after the initiation of the first draw, or at the end of a recovery period that occurs after the end of the first draw.

In the January 2022 NOPR, DOE noted that the situation in which a recovery ends during a draw likely occurs during draws with a low enough flow rate that the water heater can heat water more

quickly than the draw is removing. 87 FR 1554, 1574 (Jan. 11, 2022). DOE also explained that the energy used for the recovery efficiency calculation includes energy used to heat water and auxiliary energy; therefore, the energy associated with the first recovery period should represent the entire draw to capture all energy use. *Id.*

On January 31, 2020, DOE published in the **Federal Register** a Notice of Decision and Order⁴³ (Decision and Order) by which a test procedure waiver for certain basic models was granted to address the issue of a second recovery initiating during the draw during which the first recovery ended. 85 FR 5648. The Decision and Order prescribes an alternate test procedure that extends the first recovery period to include both the first and second recoveries. *Id.* at 85 FR 5652. In the context of the Decision and Order, DOE determined that the consideration of delivered water mass and inlet and outlet temperatures until the end of the draw is appropriately representative, and, therefore, the entire energy used from both recoveries is included. *Id.* at 85 FR 5651–5652.

In the January 2022 NOPR, after considering comments received in response to the April 2020 RFI, DOE proposed to establish a new provision that states that when the first recovery ends during a draw, the first recovery period is extended to the end of the draw and the mean tank temperature measured immediately after cut-out is used as the maximum mean tank temperature value in the recovery efficiency calculation. 87 FR 1554, 1574 (Jan. 11, 2022). In addition, DOE proposed to update the recovery efficiency equation to specify accounting for the mass of water drawn for all draws initiated during the recovery period. DOE noted that such a change would be consistent with the published Notice of Decision and Order and was supported by commenters. *Id.*

In response, BWC stated the proposed updates to the overall test procedure provide a more accurate calculation of recovery efficiency and eliminate situations where products would be disadvantaged for completing their recovery in the middle of a draw, thereby providing a more representative measurement of a product's overall energy efficiency. (BWC, No. 33 at pp. 5–6)

DOE did not receive any other comments in response to these proposals. As such, DOE is amending

appendix E to adopt the proposals from the January 2022 NOPR, which are consistent with the alternate test procedure in the Decision and Order and in ASHRAE 118.2–2022.

24-Hour Simulated-Use Test Final Hour

Although not stated explicitly in section 5.4.2 of the currently applicable appendix E, in the case that the standby period is between the first and second draw clusters, power to the main burner, heating element, or compressor is disabled during the last hour of the 24-hour simulated-use test. In the case that the standby period is after the last draw of the 24-hour simulated-use test, power to the main burner, heating element, or compressor is not disabled. Section 5.4.2 of the currently applicable appendix E states that during the last hour of the 24-hour simulated-use test, power to the main burner, heating element, or compressor shall be disabled; at 24 hours, record the reading given by the gas meter, oil meter, and/or the electrical energy meter as appropriate; and determine the fossil fuel and/or electrical energy consumed during the entire 24-hour simulated-use test and designate the quantity as Q. Section 5.4.2 of the currently applicable appendix E also provides that in the case that the standby period is after the last draw of the 24-hour simulated-use test, an 8-hour standby period is required, and this period may extend past hour 24. The procedures for the standby period after the last draw of the 24-hour simulated-use test allow for a recovery to occur at the end of the 8-hour standby period, which indicates that the power to the main burner, heating element, or compressor is not disabled. DOE's procedure, as described, may result in some confusion. Further, the method of determining the total energy use during the 24-hour simulated-use test, Q, and total test time are not explicitly stated for when a standby period occurs after the last draw of the 24-hour simulated-use test. As discussed in the following paragraphs, DOE is amending the procedures for the last hour of the 24-hour simulated-use test, consistent with its proposals in the January 2022 NOPR, to explain how to end the test for both standby period scenarios, and this amendment aligns with the updated approach in ASHRAE 118.2–2022.

In ASHRAE 118.2–2022, power is not disabled when the standby period occurs after the last draw of the test. However, if a recovery occurs between an elapsed time of 23 hours following the start of the test (hour 23) and 24 hours following the start of the test (hour 24), the following alternate

approach is applied to determine the energy consumed during the 24-hour simulated-use test: The time, total energy used, and mean tank temperature are recorded at 1 minute prior to the start of the recovery occurring between hour 23 and hour 24, along with the average ambient temperature from 1 minute prior to the start of the recovery occurring between hour 23 and hour 24 to hour 24 of the 24-hour simulated-use test. These values are used to determine the total energy used by the water heater during the 24-hour simulated-use test. This alternate calculation combines the total energy used 1 minute prior to the start of the recovery occurring between hours 23 and 24 and the standby loss experienced by the tank during the time between the minute prior to the recovery start and hour 24. This provision in section 7.4.3.2 of ASHRAE 118.2–2022 does not require the water heater to be de-energized during the standby period. Disabling power to the water heater is typically a manual operation that requires the presence of a technician. In cases where the technician does not disable power at the correct time, a retest of the 24-hour simulated-use test may be necessary. To the extent this provision would eliminate the need to ensure that a unit is switched off for the last hour of the 24-hour simulated-use test, it could reduce test burden.

In the January 2022 NOPR, after considering comments on the April 2020 RFI, DOE tentatively concluded that further evaluation of the alternate procedure presented in the March 2019 ASHRAE Draft 118.2 and April 2021 ASHRAE Draft 118.2 should be conducted before a determination is made on whether DOE should adopt such changes. However, DOE also tentatively determined that the procedure for the last hour of the 24-hour simulated-use test would benefit from further, more explicit instruction, and, thus, DOE proposed to explicitly state how to end the test depending on whether the standby period is between draw clusters 1 and 2 or after the last draw of the test. 87 FR 1554, 1575 (Jan. 11, 2022).

No comments or data were received on this topic in response to the January 2022 NOPR or July 2022 SNOPR.

As such and for the reasons previously stated, DOE is finalizing its proposal from the January 2022 NOPR to clarify how to end the test depending on when the standby period occurs. DOE will continue to evaluate the impacts of fully adopting the ASHRAE 118.2–2022 method and may consider that in a future test procedure rulemaking for the subject water heaters.

⁴³ Notice of Decision and Order in response to BWC petition for waiver is available at: www.regulations.gov/document?D=EERE-2019-BT-WAV-0020-0008.

As discussed in section III.E.4 of this document, DOE is dividing section 5.4.2 of appendix E into two sections: section 5.4.2.1, “Water Heaters that Can Have Internal Storage Tank Temperature Measured Directly,” and section 5.4.2.2, “Water Heaters that Cannot Have Internal Storage Tank Temperature Measured Directly.” The new section 5.4.2.1 of appendix E provides specific direction on the measurements to be taken if the standby period occurs at the end of the first recovery period after the last draw of the 24-hour simulated-use test. These revised instructions for the final hour of the 24-hour simulated-use test also no longer require disabling the water heater for the standby mode, a change which harmonizes with the procedure in ASHRAE 118.2–2022. DOE has determined that these provisions are appropriate only for water heaters that can have internal storage tank temperatures measured directly, because these steps require recording the mean tank temperature at various points during the final hour. For water heaters that cannot have internal storage tank temperatures measured directly, DOE is adopting an alternative method entirely (discussed in section III.E.7 of this document) which requires a standby period after the final draw and temperature measurements made via estimation.

c. Other Updates

Inlet Water Temperature Measurement Location

In its review of the ASHRAE 118.2–2022 set-up figures, DOE determined that the placement of the inlet water temperature measurement probe differs between ASHRAE 118.2–2022 and the currently applicable appendix E. In ASHRAE 118.2–2022, the inlet water temperature is always measured on the upstream side of the heat trap formed by the U-bend in the required piping, whereas the figures in appendix E vary this location (*i.e.*, either on the upstream side or on the downstream side of the U-bend) depending on the type of water heater being tested.

DOE requested information about the potential impact of this measurement location on energy efficiency results in the January 2022 NOPR. 87 FR 1554, 1569 (Jan. 11, 2022).

On this topic, BWC stated there are inconsistencies in the placement of inlet thermocouples in the set-up figures currently shown in appendix E. BWC suggested adopting the figures in ASHRAE Standard 118.2, as they are representative of most set-ups and illustrate placement of the inlet thermocouples on the upstream side of

the U-bend in all instances. BWC also more generally urged DOE to adopt the water heater test set-up figures adopted in ASHRAE 118.2–2022, stating that it is not aware of any testing laboratory that does not utilize the set-ups depicted in these figures. (BWC, No. 33 at pp. 2–3) (DOE understands the “inconsistencies” mentioned by BWC as referring to the differences in temperature probe placement for different types of water heaters, as mentioned at the beginning of this subsection.)

AET indicated that there may be problems with the location and orientation of the bypass (purge) line connection in the ASHRAE 118.2–2022 test set-ups when testing small water heaters (*i.e.*, electric instantaneous water heaters). The commenter claimed that without a bypass line installed at the water inlet, it is not possible to meet the test conditions and tolerances for the inlet water temperature during test draws when the measurement location is as specified in the current appendix E test procedure. AET explained that the location of the bypass line combined with the rest of the piping configuration for measuring inlet water temperature can induce a small amount of flow in the piping near the inlet to the water heater, even when a draw is not being conducted and there is no flow through the water heater. According to AET, flow-activated water heaters with especially sensitive flow sensors could initiate heating upon sensing this “false flow,” and this would in turn cause the energy consumption under test to increase in an unrepresentative manner. AET provided a detailed description of this phenomenon in its public comment and stated that its claims were substantiated by review of recent test data, though these data were not provided to DOE. AET suggested that one potential solution to the identified problem could be to move the connection point of the purge line and the inlet measurement location further from the water heater. In addition, AET suggested adjusting the various pipe T-junctions and their orientations such that the momentum of a cold-water purge will be directed horizontally away from the pipe direction going to the water heater and not induce a false flow, with the commenter opining that this change could be implemented for all types of water heaters. (AET, No. 29 at pp. 6–9)

As discussed in the January 2022 NOPR, maintaining the same inlet water temperature measurement location for all water heater types (*i.e.*, harmonizing with ASHRAE 118.2–2022) would simplify the test set-up as compared to

the requirements of the currently applicable appendix E. However, DOE did not have sufficient information at the time to propose such harmonization. 87 FR 1554, 1568–1569 (Jan. 11, 2022).

In the January 2022 NOPR, DOE noted that use of a bypass loop is not the only possible test set-up for meeting the test conditions within appendix E. 87 FR 1554, 1569 (Jan. 11, 2022). However, based on the comment from BWC, DOE understands that many test facilities do use a bypass loop as a solution to having to stabilize the inlet water conditions. After considering the comments from AET and BWC, DOE has determined that laboratories are likely to continue to use bypass lines regardless of the placement of the inlet water temperature measurement, because a bypass line is simple to install and relatively low-cost. If this occurs, then there is a risk that UEF ratings for certain flow-activated water heaters with highly sensitive sensors may be lower due to the additional energy consumption of the water heater when a false flow is sensed. DOE is not incorporating the updates found in the ASHRAE 118.2–2022 figures. Instead, DOE is maintaining the current set-up directions for inlet water temperature measurement in appendix E and, which will allow for the continued use of a bypass line when necessary and appropriate. Regarding AET’s concerns about the location of the bypass loop for certain electric instantaneous water heaters, DOE notes that it has not observed the issue in any of its testing. Further, DOE is not adopting the figures in ASHRAE 118.2–2022, so, therefore, the Department is not specifying the location of the bypass loop in its test set-up. Accordingly, during testing, there will be sufficient flexibility to locate the bypass line, when necessary, in a location that results in representative operation and performance of the unit under test.

FHR Test Initiation Criteria

ASHRAE 118.2–2022 includes additional criteria defining the start of the FHR test as compared to DOE’s test procedure at appendix E. These differences are briefly explained in the following paragraphs.

Section 5.3.3.3 of the currently applicable appendix E states that prior to the start of the FHR test, if the water heater is not operating (*i.e.*, heating water), initiate a draw until cut-in⁴⁴

⁴⁴ “Cut-in” is defined in section 1 of appendix E as “the time when or water temperature at which a water heater control or thermostat acts to increase the energy or fuel input to the heating elements, compressor, or burner.”

(i.e., when the water heater begins heating water). The draw is then terminated any time after cut-in, and the water heater is operated until cut-out.⁴⁵ Once the maximum mean tank temperature is observed after cut-out, the initial draw of the FHR test begins.

Section 7.3.3.3 of ASHRAE 118.2–2022 specifies that the draw preceding the initial draw of the FHR test must proceed until the outlet temperature drops 15 °F below the maximum outlet temperature observed, or until a draw time limit⁴⁶ is reached. If the draw time limit is reached before the outlet temperature drops 15 °F below the maximum outlet temperature observed, then the main heating source of the water heater is shut off, and the draw is continued until the outlet temperature has dropped 15 °F below the maximum outlet temperature. Requiring the outlet temperature to drop 15 °F below the maximum outlet temperature may provide a more consistent starting condition for the FHR test compared to the pre-conditioning method specified in the currently applicable DOE test procedure because draws of varying lengths can create different internal tank temperature profiles.

Thus, in the January 2022 NOPR, DOE tentatively determined that the additional requirement to tie the length of the initial draw to a specific outlet temperature (which in some cases would extend the draw length as compared to the currently applicable DOE test procedure) could increase the repeatability of the FHR test. 87 FR 1554, 1570–1571 (Jan. 11, 2022). However, DOE also argued that, with both the ASHRAE 118.2–2022 and appendix E initiation criteria, the water heater can be considered “fully heated” and to have similar internal energy content before beginning the FHR test, although differences may be present due to the internal water temperature gradient throughout the tank. DOE did not propose an amendment to include pre-FHR test conditioning, because it was unclear how these differences in internal tank temperature would affect the test results. 87 FR 1554, 1571 (Jan. 11, 2022).

In response, A.O. Smith stated that the 15 °F initiation criterion and the additional specificity on draw

termination in ASHRAE 118.2 would improve consistency and repeatability and would not conflict with the currently applicable DOE test procedure, and, therefore, those provisions should be adopted. (A.O. Smith, No. 37 at pp. 6–7) BWC also urged DOE to consider adopting the pre-FHR pre-conditioning requirements specified in ASHRAE 118.2. BWC stated that the specifications in ASHRAE 118.2 only add parameters to achieve better testing consistency, and that the currently applicable test procedure may frequently yield inconsistencies from short pre-draws prior to the initiation of the FHR test, thereby causing storage water heaters to be unable to meet the test procedure’s 125 °F ± 5 °F requirement. BWC stated that changes to the pre-FHR pre-conditioning requirements were agreed to by manufacturers during the development of ASHRAE 118.2, and that manufacturers are prepared to undertake the burden of any re-testing in favor of a more robust test method. (BWC, No. 33 at pp. 4–5)

In response, DOE notes that commenters did not indicate the impact of this change on rated values of products nor did they provide any data in that regard. Additionally, DOE is not aware of storage water heaters which are not able to meet the 125 °F ± 5 °F outlet temperature requirement, but if this is demonstrated to be a problem, the Department would address the impacted products in a future rulemaking once more data are collected. Although the Department acknowledges the potential benefits to consistency and repeatability that may accompany a pre-FHR pre-conditioning requirement, without a clear understanding of the associated impact on ratings, DOE is not adopting this change to the Federal test procedure at this time.

Additionally, DOE notes that the draw time limit in section 7.3.3.3 of ASHRAE 118.2–2022 is a function of the “nominal” capacity of the water heater (in gallons or liters). Nominal capacity is typically not equal to the rated storage volume, and there is no standardized methodology in appendix E or in ASHRAE 118.2–2022 to determine nominal capacity; hence, there is a concern that the draw time limits could be different for two identical water heaters labeled at two different nominal capacities. If DOE were to adopt the essence of the initiation criteria in ASHRAE 118.2–2022, DOE would consider substituting “nominal capacity” for “rated storage volume” (because rated storage volume is a standardized metric with a test method associated with it in section 5.2.1 of

appendix E). This deviation could cause additional testing costs for manufacturers.

For these reasons, DOE is maintaining the FHR test initiation criteria currently found in appendix E, which provide that the preconditioning draw can be terminated any time after cut-in, and the water heater is operated until cut-out. Once the maximum mean tank temperature is observed after cut-out, the initial draw of the FHR test begins.

24-Hour Simulated-Use Test Initiation Criteria

Similar to the initiation criteria discussed in the previous section for the FHR test, section 7.4.2 of ASHRAE 118.2–2022 includes criteria for a pre-24-hour simulated-use test draw, which ends after either the outlet temperature drops by 15 °F or the draw time limit is reached. Section 5.4.2 of the currently applicable appendix E requires that the water heater sit idle for 1 hour prior to the start of the 24-hour simulated-use test, during which time no water is drawn from the unit and no energy is input to the main heating elements, heat pump compressor, and/or burners. Appendix E provides no instruction on how to condition the tank prior to this one hour. However, as discussed in the previous section, it remains unclear how the outlet temperature drop criteria and the draw time limit will affect the internal tank temperature at the start of the 24-hour simulated-use test and how this difference in internal tank temperatures will affect the test results.

In the January 2022 NOPR, DOE did not propose to amend appendix E to include the April 2021 ASHRAE Draft 118.2 24-hour simulated-use test initiation criteria (which was substantially the same as the 24-hour simulated-use test initiation criteria included in ASHRAE 118.2–2022) and invited comment and data that provide information on the impact of this update on UEF results. 87 FR 1554, 1573 (Jan. 11, 2022).

On this topic, BWC argued that the initiation criteria in ASHRAE Standard 118.2 should also be adopted for the 24-hour simulated-use test so as to improve the repeatability and reproducibility of the test procedure. (BWC, No. 33 at pp. 4–5) DOE considered this comment, as well as those received regarding the FHR test initiation criteria, and has determined that it still lacks the necessary data that would provide a clear understanding of the impact that this update would have on ratings. Accordingly, for the same reasons stated in the previous section, DOE is not adopting this change in this final rule.

⁴⁵ “Cut-out” is defined in section 1 of appendix E as “the time when or water temperature at which a water heater control or thermostat acts to reduce to a minimum the energy or fuel input to the heating elements, compressor, or burner.”

⁴⁶ The draw time limit is the rated storage capacity divided by the flow rate times 1.2 (i.e., for a 75-gallon water heater the draw time limit would be 30 minutes, or 75 gallons divided by 3 gpm times 1.2).

FHR Test Termination Temperature

Section 7.3.3.4 of ASHRAE 118.2–2022 includes additional criteria regarding water draws during the FHR test, as compared to the current DOE test procedure. The FHR test required in section 5.3.3 of appendix E specifies a series of water draws over the course of one hour. After each water draw is initiated, the draw is terminated when the outlet water temperature decreases 15 °F from the maximum outlet water temperature measured during the draw. For example, if after initiating a water draw, the outlet water temperature reaches a maximum temperature of 125 °F, the water draw would continue until the outlet water temperature drops to 110 °F, at which time the water draw would be terminated. Similar to the public review drafts of ASHRAE 118.2, section 7.3.3.4 of ASHRAE 118.2–2022 specifies that water draws during the FHR test terminate if either: (1) The outlet water temperature decreases by the quantity of nominal delivery temperature minus 110 °F from the maximum outlet water temperature⁴⁷ or (2) the outlet water temperature decreases to 105 °F, regardless of the maximum outlet water temperature measured during the draw. Setting a minimum temperature threshold of 105 °F would reflect that, in practice, consumers would likely stop drawing water when it gets below 105 °F, as the water would no longer be considered “hot.”

A temperature of 105 °F would be the FHR test termination temperature if the maximum outlet temperature were 120 °F (a 15 °F difference) as per the current DOE test procedure. 120 °F is the lower end of the outlet temperature tolerance band specified in section 5.2.2.2 of appendix E (*i.e.*, 125 °F ± 5 °F). However, as discussed in section III.A.4.b of this document, there exist low-temperature water heaters that are not capable of maintaining these temperatures when tested to the flow rates required in section 5.2.2.2 of appendix E, and this raises the question of whether a criterion for ending a draw when the outlet temperature reaches 105 °F would be representative for all consumer water heaters and residential-duty commercial water heaters.

In this rulemaking, DOE sought information and feedback from stakeholders on the potential impacts and implications of setting an FHR test

termination temperature such as 105 °F. In particular, DOE was interested in data which would determine the representativeness of a 105 °F minimum temperature based on consumer use and expectations. 85 FR 21104, 21109 (April 16, 2020). While several stakeholders generally supported the use of a termination temperature, two manufacturers indicated that more testing and investigation are necessary prior to adopting this. 87 FR 1554, 1571, 1572 (Jan. 11, 2022). In commenting on the April 2020 RFI, Rheem suggested 100 °F instead to account for low-temperature water heaters. (Rheem, No. 14 at p. 3) In the January 2022 NOPR, DOE tentatively determined that, based on a review of existing test data, the 105 °F termination temperature criterion would affect only a small number of tests, if any. Additionally, DOE noted that Rheem’s suggested 100 °F termination temperature would most likely not be representative for all types of consumer water heaters and residential-duty commercial water heaters. Given the need for further evaluation of the specific termination temperature and its potential impacts, DOE did not propose to adopt a termination temperature for the FHR test in the January 2022 NOPR. 87 FR 1554, 1572 (Jan. 11, 2022).

In response to the January 2022 NOPR, BWC reiterated that DOE should include the 105 °F termination temperature established in ASHRAE Standard 118.2 to provide additional clarity and reflect representative usage. (BWC, No. 33 at p. 4) However, commenters did not provide additional data or consumer usage information to indicate whether 105 °F is representative of the minimum delivery temperature consumers generally expect. DOE was likewise unable to obtain widespread field use data on its own initiative.

As of this final rule, there remains significant uncertainty regarding what the value of the termination temperature should be. As noted previously, Rheem indicated 100 °F should be used to account for low-temperature water heaters. Section 7.3.3.4 of ASHRAE 118.2–2022 uses a 105 °F minimum termination temperature, which was recommended by several stakeholders. DOE did not receive, nor has DOE found, any additional data regarding the minimum delivery temperature consumers would generally expect. However, should the water heater provide a maximum delivery temperature during the test which is lower than 120 °F (which may potentially occur even if the unit’s controls are adjusted properly according

to section 5.2.2 of appendix E), a 15 °F temperature drop would result in termination below 105 °F. DOE expects this would impact a relatively small number of units, but at this time, there is inadequate test data to indicate how frequently this may occur, which types of products would be affected, and how they would be affected by a specific termination temperature.

Given these considerations, DOE is not adopting a minimum termination temperature for the FHR test in this rulemaking.

FHR Test Final Draw Volume

Section 5.3.3.3 of appendix E includes a provision for the FHR test requiring that if the final draw is not initiated prior to one hour from the start of the test, then a final draw is imposed at the elapsed time of one hour. In this situation, calculations presented in section 6.1 of appendix E are used to determine the volume drawn during the final draw for purposes of calculating FHR. The volume of the final draw is “scaled” based on the temperature of the water delivered during the final draw as compared to the temperature of the water delivered during the previous draw to account for the water removed in the final draw being at a lower temperature than previous draws. The scaled final draw volume is added to the total volume drawn during the prior draws to determine the FHR. ASHRAE 118.2–2022 does not include a final draw volume scaling calculation for the case in which a draw is not in progress at one hour from the start of the test and a final draw is imposed at the elapsed time of one hour. Instead, the ASHRAE 118.2–2022 method calculates FHR as the sum of the volume of hot water delivered giving full credit to the final draw.

The methodology for conducting the FHR test, and in particular the issue of whether to scale the final draw, was considered by DOE in a final rule that was published in the **Federal Register** on May 11, 1998 (the May 1998 Final Rule). 63 FR 25996. In the May 1998 Final Rule, DOE determined that scaling the final draw volume based on the outlet water temperature was appropriate and was included to adjust the volume of the last draw to account for the lower heat content of the last draw compared to the earlier draws with fully heated water. *Id.* at 63 FR 25996, 26004–26005.

In the January 2022 NOPR, after considering comments on the April 2020 RFI, DOE proposed not to update the final draw volume provisions in the FHR test because DOE tentatively determined that scaling the final draw

⁴⁷ The nominal delivery temperature in section 2.4 of the appendix E test procedure is 125 °F, and 125 °F – 110 °F = 15 °F. Thus, for a nominal delivery temperature of 125 °F, ASHRAE 118.2–2022 and the DOE test procedure both use a 15 °F drop to indicate when the draw must be terminated.

volume based on outlet temperature is more representative of the actual use in the field. 87 FR 1554, 1573 (Jan. 11, 2022). As discussed in the January 2022 NOPR, AHRI and individual manufacturers recommended that DOE remove the scaling calculations to harmonize with ASHRAE 118.2–2022, indicating that this change would have minimal impact on ratings. *Id.* at 87 FR 1572. CSA, however, raised concerns with that approach, because water is usually tempered by the end user, and the commenter argued that a water heater that delivers a volume of water at a higher temperature should not be credited the same as one that delivers roughly the same volume at a lower temperature. CSA also noted that removing the scaling of the final draw volume could possibly move water heaters to a higher draw pattern. *Id.*

After considering these comments, DOE noted in the January 2022 NOPR that the scaling of the final draw accounts for the possible lower heat content of the last draw as compared to earlier draws. DOE further explained that the test procedure specifies a constant flow rate throughout testing, and, as water is drawn from a typical non-flow-activated water heater, the water temperature decreases. As the temperature of the water delivered by the water heater decreases, mixing valves at the point of use will reduce the amount of cold water being mixed with the hot water in order to maintain the same delivery temperature to the consumer. If the water from the water heater is at a lower temperature, more of this hot water will be required to reach the correct temperature at the fixture. Thus, DOE tentatively determined that scaling the final draw volume based on outlet temperature is more representative of the actual use in the field. 87 FR 1554, 1572–1573 (Jan. 11, 2022). Furthermore, DOE also noted that if the scaling calculation were removed, many water heaters would have a different FHR than under the currently applicable appendix E, and some would change draw pattern bins, which would require retesting for UEF and thereby increase manufacturer burden. *Id.*

In response, BWC strongly disagreed with DOE's position that scaling the final draw based on outlet temperature is representative of field use. BWC reiterated its earlier comments that scaling should not be necessary and would potentially lead to unrepeatable test results depending on the timing of the last draw (*e.g.*, creating the possibility of two different FHR ratings for the same product). BWC instead recommended the procedure in

ASHRAE Standard 118.2, where the sum of the volume of hot water delivered is used without scaling the final draw. BWC argued that this approach would more fairly account for water heated by the product. (BWC, No. 33 at pp. 4–5)

After considering BWC's comment, DOE maintains that when the final draw is imposed at the end of the FHR test, scaling the volume of water drawn by temperature is representative and appropriate. Scaling the final draw allows FHR to capture the difference in hot water delivery capacity between water heaters that provide roughly the same amount of hot water in the final draw, but where one water heater provides water at a higher temperature than the other. This is appropriate because, as noted, the water temperature is usually tempered at the fixture to provide the end user with water at the target outlet temperature. If the hot water is at a lower temperature, more water is required to provide the user with water at the target temperature, while less water would be needed if the water is at a higher temperature. Therefore, DOE has concluded that it is appropriate for FHR to reflect this difference in capacity, which would not be accounted for if the scaling calculation is removed. DOE also notes that, at this time, there is limited information available to assess the potential impacts of removing the scaling calculation on UEF and FHR ratings, and as a result DOE is not amending the appendix E test procedure to include the full volume of the final draw.

24-Hour Simulated-Use Test Standby Period Duration

Appendix E includes a standby⁴⁸ loss measurement period between the first and second draw clusters⁴⁹ of the 24-hour simulated use test. During this time, temperature data is recorded and used to calculate the standby heat loss coefficient. *See* section 5.4.2 of appendix E. Sections 7.4.3.1 and 7.4.3.2 of ASHRAE 118.2–2022 add a condition that the standby period data can be recorded between the first and second draw clusters only if the time between the observed maximum mean tank temperatures after cut-out following the

first draw cluster to the start of the second draw cluster is greater than or equal to 6 hours. Otherwise, the standby period data would be recorded after the last draw of the test. This condition would provide a sufficiently long standby period to determine standby loss, which might make this calculation more repeatable and the results more representative of standby losses experienced in an average period of use. However, this might also cause the test to extend beyond a 24-hour duration.

The currently applicable DOE test procedure does not have a 6-hour minimum for a standby period between the first and second draw clusters of the 24-hour simulated use test. However, section 5.4.2 of appendix E states, “In the event that the recovery period continues from the end of the last draw of the first draw cluster until the subsequent draw, the standby period will start after the end of the first recovery period after the last draw of the simulated-use test, when the temperature reaches the maximum average tank temperature, though no sooner than five minutes after the end of this recovery period. The standby period shall last eight hours, so testing will extend beyond the 24-hour duration of the simulated-use test.” As such, DOE does currently have a minimum standby period duration, but only under the particular case that there is no opportunity to observe standby operation between the first draw cluster and the second draw cluster.

In the April 2020 RFI, the Department requested comments on potentially adding a minimum standby period length of 6 hours and the associated data collection and calculations. 85 FR 21104, 21110 (April 16, 2020). Commenters were split on the appropriateness of this amendment, with some stakeholders noting a key concern would be the extension of the total test period time to over 24 hours in many cases. 87 FR 1554, 1574 (Jan. 11, 2022).

The standby heat loss coefficient (*i.e.*, UA) is the main result calculated from the data recorded during the standby period. DOE reviewed its available test data and found that, generally, the standby period duration has little effect on the UA value, and the UA value in turn has very little effect on UEF. As discussed in the January 2022 NOPR, UA is used only to adjust the daily water heating energy consumption to the nominal ambient temperature of 67.5 °F (19.7 °C); given that the ambient temperature range is relatively narrow (*i.e.*, 65 °F to 70 °F (18.3 °C to 21.1 °C)), the adjustment has only a minimal impact on the daily water heating

⁴⁸ “Standby” is defined in section 1.12 of appendix E as “the time, in hours, during which water is not being withdrawn from the water heater.”

⁴⁹ A “draw cluster” is defined in section 1 of appendix E as “a collection of water draws initiated during the 24-hour simulated-use test during which no successive draws are separated by more than 2 hours.” There are two draw clusters in the very small draw pattern and three draw clusters in the low, medium, and high draw patterns.

energy consumption. 87 FR 1554, 1574 (Jan. 11, 2022).

In commenting on the January 2022 NOPR, BWC generally disagreed with DOE's tentative determination that including a 6-hour standby period minimum would not significantly impact UEF ratings. BWC also mentioned that it has experienced difficulty having adequate time to calculate the standby loss coefficient after the first draw cluster. Thus, BWC reiterated its support for the methodology in ASHRAE 118.2–2022 but stated that the company would like time to examine this matter before commenting further. (BWC, No. 33 at p. 6) BWC did not provide further comments or data on this topic in response to the July 2022 SNO PR.

Considering that DOE did not receive further comments demonstrating a quantifiable impact of the standby period length on the UEF, DOE concludes, as initially presented in the January 2022 NOPR, that based on its test data, the duration of the standby period does not significantly impact the UEF result. Therefore, in order to minimize burden (*i.e.*, total test duration) on manufacturers and laboratories while still allowing results to be representative, repeatable, and reproducible, DOE is not amending the appendix E test procedure to require the standby period to be a minimum of 6 hours in duration.

C. Test Conditions and Tolerances

In the January 2022 NOPR, DOE made a number of proposals to the test conditions and tolerances that were intended to improve representativeness, reduce testing burden, and/or harmonize with industry test methods. 87 FR 1554, 1558–1559 (Jan. 11, 2022). These proposals included changes to the electric supply voltage tolerance, ambient condition tolerances, gas supply pressure and manifold pressure tolerances, and flow rate tolerances for certain water heaters. *Id.* In addition, in the July 2022 SNO PR, DOE made supplemental proposals regarding the tolerance on flow rate during the UEF test for models with rated storage volumes less than 2 gallons and max GPM less than 1 gallon, and regarding optional test conditions for heat pump water heaters. 87 FR 42270, 42273 (July 14, 2022). These proposals were intended to improve repeatability and reproducibility and harmonize with industry testing practices, respectively. *Id.*

In response to the January 2022 NOPR proposals, APGA provided general comments stressing the importance of ensuring accuracy, repeatability, and

reproducibility in a test procedure that is not unduly burdensome to conduct. (APGA, No. 38 at pp. 1–2) AHRI indicated its support of DOE's proposals to reduce test burden; specifically, AHRI supported increasing test tolerances for ambient temperature and relative humidity, and extending untested provisions to include electric instantaneous water heaters. (AHRI, Jan. 27, 2022 Public Meeting Transcript, No. 27 at p. 40)

As previously discussed in section I.A of this final rule, DOE's efforts are aligned with EPCA requirements to create test procedures that are representative of average use without being unduly burdensome to conduct. (42 U.S.C. 6293(b)(3)) Each of the proposed changes to test conditions and tolerances, along with specific stakeholder comments received and DOE's responses, are discussed further in the subsections that immediately follow.

1. Supply Water Temperature Measurements

Section 2.3 of the currently applicable appendix E specifies maintaining the supply water temperature at $58^{\circ}\text{F} \pm 2^{\circ}\text{F}$ ($14.4^{\circ}\text{C} \pm 1.1^{\circ}\text{C}$). During the 24-hour simulated-use test, maintaining the supply water temperature within this range can be difficult at the immediate start of a draw due to the short time between draw initiation and the first measurement at 5 seconds (with subsequent measurements every 3 seconds thereafter), as required by sections 5.4.2 and 5.4.3 of appendix E. In some test configurations, particularly during the lower flow rate water draws, the inlet water and piping may retain heat from a previous draw, causing the water entering the unit during the initial measurements to be slightly outside of tolerance. Any supply water temperature reading outside of the test tolerances would invalidate a test. However, due to the small percentage of total water use that would be affected, supply water temperatures that are slightly out of tolerance for the first one or two data points would have a negligible effect on the overall test result.⁵⁰ This issue is less evident during the FHR test, which specifies an initial temperature measurement 15 seconds after the start of the water draw. This is not an issue during the Max

GPM test due to the system being in steady state during the entire test.

In the April 2020 RFI, DOE requested feedback on whether one or two supply water temperature data points outside of the test tolerance at the beginning of a draw would have a measurable effect on the results of the test. 85 FR 21104, 21111 (April 16, 2020). DOE further requested feedback on whether it should consider relaxing the requirement for supply water temperature tolerances at the start of a draw, and if so, which methods are most appropriate for doing so while maintaining accuracy and repeatability. *Id.* at 85 FR 21111–21112. DOE received comments regarding these tolerances from stakeholders including AHRI, A.O. Smith, NEEA, Rheem, BWC, CSA, Rinnai, and SMTI. These comments are summarized and discussed in section III.C.3.a of the January 2022 NOPR. 87 FR 1554, 1576–1577 (Jan. 11, 2022).

In response to comments made on the April 2020 RFI, DOE proposed in the January 2022 NOPR to increase the time between initiating the draw and first measurement of supply water temperature from 5 seconds to 15 seconds in sections 5.4.2 and 5.4.3 of appendix E, as recommended by the commenters. 87 FR 1554, 1577 (Jan. 11, 2022). DOE reasoned that the proposed change may, if adopted, reduce test burden by reducing the occurrence of a test being invalidated (which would require re-testing) due to the first one or two water temperature readings exceeding the defined temperature tolerance. Further, this proposed change would eliminate the need to amend the supply water temperature tolerances which, outside of the time period at the start of a draw, are relatively easy to maintain. *Id.*

In response to the January 2022 NOPR, A.O. Smith reiterated its previous comment that there would be no measurable effect on test results by allowing one or two supply water temperature data points outside of the current test tolerance at the beginning of a draw. The commenter suggested that DOE should adopt the test set-up described in ASHRAE 118.2–2022, which includes a purge line designed by third-party laboratories to help achieve tolerances on supply water temperature. A.O. Smith also commented that widening tolerances in certain cases may ultimately cause variations in test results. (A.O. Smith, No. 37 at p. 5) In contrast, BWC supported DOE's proposal to increase the span between the first draw initiation and the first temperature measurement from 5 seconds to 15 seconds because it would reduce testing burden; the 5-second

⁵⁰For example, the first two temperature readings would reflect 8 seconds of water flow, in comparison to total water draw durations ranging from 1 minute to over 8 minutes, according to the water draw patterns defined in Tables III.1, III.2, III.3, and III.4 of appendix E.

time interval requires significant and frequent purging which, if not conducted, may invalidate tests. (BWC, No. 33 at p. 7) In response to A.O. Smith, DOE reiterates its position, as previously stated in the January 2022 NOPR, that although one or two measurements outside the current tolerance may not have an effect on test results, DOE has chosen to alleviate the issue of potential test invalidation by instead increasing the time between initiating the draw and first measurement of supply water temperature. *Id.*

After considering these comments, DOE has decided to adopt the proposal from the January 2022 NOPR to increase the time between initiating the draw and first measurement from 5 seconds to 15 seconds in sections 5.4.2 and 5.4.3 of appendix E. In response to A.O. Smith's suggestion that DOE adopt the test set-up in ASHRAE 118.2–2022, as discussed in detail in section III.B.2.c of this document, DOE is maintaining the current set-up directions for inlet water temperature measurement in appendix E and not incorporating the updates found in the ASHRAE 118.2–2022 figures because the addition of a bypass line and thermal break was determined to be optional. However, increasing the time of first recordation of the supply water temperature measurement after the start of a draw from being taken at 5 seconds to being taken at 15 seconds will allow units to reach a supply temperature within tolerance without need for modifications to the test set-up.

2. Gas Pressure

For gas-fired water heaters, sections 2.7.2 and 2.7.3 of the currently applicable appendix E require maintaining the gas supply pressure in accordance with the manufacturer's specifications; or if the supply pressure is not specified, maintaining a supply pressure of 7 to 10 inches of water column (1.7 to 2.5 kPa) for natural gas and 11 to 13 inches of water column (2.7 to 3.2 kPa) for propane gas. In addition, for gas-fired water heaters with a pressure regulator, sections 2.7.2 and 2.7.3 of the currently applicable appendix E require the regulator outlet pressure to be within ± 10 percent of the manufacturer's specified manifold pressure.

In the January 2022 NOPR, DOE noted that from a review of product literature, DOE found that many gas-fired water heaters with modulating input rate burners have a factory preset manifold pressure that is computer-controlled and cannot be adjusted directly. Further, the manufacturer-specified manifold pressure typically refers to

when the water heater is operating at the maximum firing rate. As a result, and after considering comments on the April 2020 RFI, DOE proposed to remove the ± 10 percent manifold pressure tolerance for certain gas-fired water heaters, recognizing that some of these products do not provide the capability to adjust the manifold pressure. 87 FR 1554, 1578–1579 (Jan. 11, 2022). DOE also proposed the addition of an absolute manifold pressure tolerance of ± 0.2 inches water column, which would be used for gas-fired water heaters with a zero-governor valve for which the ± 10 percent tolerance would be overly restrictive. *Id.* For example, applying the ± 10 percent to a manufacturer recommended gas pressure of 0.1 inches water column would result in a tolerance of ± 0.01 inches of water column, which is less than both the accuracy and precision tolerances required for gas pressure instrumentation within section 3.1 of the currently applicable appendix E. Further, DOE proposed that the required gas pressures within appendix E apply when operating at the manufacturer's specified input rate or, for modulating input rate water heaters, the maximum input rate. *Id.*

DOE did not receive comments in response to the previously discussed amendments to sections 2.7.2 and 2.7.3 of appendix E proposed in the January 2022 NOPR concerning manifold pressure tolerance for gas-fired water heaters. Accordingly, DOE is adopting these amendments in this final rule for the reasons previously stated.

3. Input Rate

In addition to the gas pressure requirements, section 5.2.3 of the currently applicable appendix E test procedure requires maintaining an hourly Btu rating (*i.e.*, input rate) that is within ± 2 percent of the value specified by the manufacturer (*i.e.*, the nameplate value). DOE has observed during testing that an input rate cannot be achieved that is within ± 2 percent of the nameplate value while maintaining the gas supply pressure and manifold pressure within the required ranges for some gas-fired water heaters. In such instances, it is common practice for the testing laboratory to modify the size of the orifice that is shipped with the water heater; for example, the testing laboratory may enlarge the orifice to allow enough gas flow to achieve the nameplate input rating within the specified tolerance, if the input rate is too low with the orifice as supplied. For commercial water heating equipment, DOE addressed this issue by specifying in the product-specific enforcement

provisions that, if the fuel input rate is still not within ± 2 percent of the rated input after adjusting the manifold and supply pressures to their specified limits, DOE will attempt to modify the gas inlet orifice. 10 CFR 429.134(n)(ii).

In the April 2020 RFI, DOE requested comment on whether provisions should be added to the test procedure at appendix E to address water heaters that cannot operate within ± 2 percent of the nameplate rated input as shipped from the factory and how this issue should be addressed. 85 FR 21104, 21112 (April 16, 2020). On this topic, DOE received comments from manufacturers and their representatives, including AHRI, Rheem, Rinnai, BWC, and CEC, suggesting various methods to achieve the ± 2 percent tolerance. These comments are summarized and discussed in the January 2022 NOPR. 87 FR 1554, 1579 (Jan. 11, 2022).

After considering these comments, DOE proposed in the January 2022 NOPR to add provisions to appendix E to provide further direction for achieving an input rate that is ± 2 percent of the nameplate value specified by the manufacturer. 87 FR 1554, 1579 (Jan. 11, 2022). Specifically, DOE proposed to modify section 5.2.3 of appendix E to require that the following steps be taken to achieve an input rate that is ± 2 percent of the nameplate value specified by the manufacturer:

(1) Attempt to increase or decrease the gas outlet pressure within ± 10 percent of the value specified on the nameplate to achieve the nameplate input (within ± 2 percent).

(2) If the fuel input rate is still not within ± 2 percent of the nameplate input, increase or decrease the gas supply pressure within the range specified on the nameplate.

(3) If the measured fuel input rate is still not within ± 2 percent of the certified rated input, modify the gas inlet orifice as required to achieve a fuel input rate that is ± 2 percent of the nameplate input rate.

Id.

Regarding commenters' suggestion to check for leaks as an additional step in the process, DOE noted that gas leak detection should be part of a test laboratory's normal operating procedures, and, therefore, detection does not require specification within DOE's test procedures. 87 FR 1554, 1579 (Jan. 11, 2022). DOE also explained that the purpose of adjusting the orifice during testing is to ensure that the performance of the water heater is representative of performance at the Btu rating specified by the manufacturer on the product's nameplate, which informs

the field installation conditions. Allowing for adjustment of the orifice reduces test burden and improves repeatability by providing test laboratories with a last resort to maintain the hourly Btu rating as specified by the manufacturer. Further, DOE noted that the proposal that the orifice be modified would occur only after other options have been exhausted. Lastly, DOE proposed that should a unit fail to achieve an input within the 2 percent tolerance, DOE would continue testing with the measured input value as opposed to the rated value (*i.e.*, the fuel input rate found via testing would be used for the purpose of determining compliance). 87 FR 1554, 1579–1580 (Jan. 11, 2022).

In response to DOE's proposals on this topic in the January 2022 NOPR, AHRI agreed with the Department's proposal to first adjust the manifold pressure and then modify the orifice if an input rate within 2 percent of the nameplate input rating is not achieved. (AHRI, No. 40 at pp. 1–2)

Rheem, AHRI, and BWC commented that if the unit cannot reach input rates within ± 2 percent of the nameplate rate, the unit is likely faulty, and the test results should not be accepted. (Rheem, No. 31 at pp. 2–3; AHRI, No. 40 at pp. 1–2; BWC, No. 33 at p. 8) AHRI suggested that if this occurs, the manufacturer should be contacted. AHRI also stated that laboratory testing should only be performed by qualified laboratory personnel, adding that the architecture of oil-fired water heaters also introduces additional complexity for these products. (AHRI, No. 40 at p. 2) BWC also commented that last-resort orifice adjustments should only be performed by qualified laboratory personnel, and indicated that DOE may wish to reference language in Section A1.3.2.1.10 of the AHRI Residential Water Heater Operations Manual.⁵¹ (BWC, No. 33 at p. 7)

In response to these comments, DOE agrees with commenters that testing should generally be performed at

⁵¹ AHRI maintains an Operations Manual for Residential Water Heater Certification Program (AHRI Residential Water Heaters Operations Manual), which addresses how testing will be done in the AHRI certification program. Section A1.3.2.1.10 of the January 2022 edition of the AHRI Operations Manual for its Residential Water Heaters states: "If adjusting the manifold pressure does not achieve the rated input, the operator shall re-orifice the unit using an alternate orifice supplied by the manufacturer. [Note: Manufacturers are to supply test facility with a selection of orifices for use at the test facility. When a test unit is re-orificed, the test facility will notify the manufacturer of the alternate orifice used, and the manufacturer shall re-supply the test facility with a replacement orifice." See: www.ahrinet.org/Portals/OM/RWH_OM.pdf. (Last accessed July 21, 2022.)

accredited laboratory institutions by qualified personnel. In response to BWC's suggestion that DOE reference section A1.3.2.1.10 of the AHRI Residential Water Heater Operations Manual, DOE notes that the amendments to section 5.2.3 of appendix E are consistent with the instructions in the AHRI Residential Water Heater Operations Manual in that they both require a modification to the orifice, with the AHRI Operations Manual requiring the testing laboratory to "re-orifice" the unit and the language DOE is adopting requiring the test agency to "modify" the orifice. The finalized amendment would provide a more flexible approach than the language of section A1.3.2.1.10 of the AHRI Residential Water Heater Operations Manual by not requiring involvement by the water heater manufacturer in any modifications to the orifice. DOE notes that a unit not achieving the nameplate input rate within ± 2 percent could represent a malfunctioning unit or a broader issue in the design of the model. Under the proposed test approach, such models would be tested and evaluated for compliance based on its actual performance.

With regards to oil-fired water heaters, the amended section 5.2.3 provisions to appendix E reference the fuel oil supply requirements in section 2.7.4 of appendix E, which provide adequate direction for the adjustment.

After evaluating these comments, DOE is adopting modifications to appendix E and 10 CFR 429.134 concerning input rate provisions as proposed in the January 2022 NOPR and for the reasons previously stated.

4. Ambient Test Condition Tolerances

Section 2.2 of appendix E specifies maintaining the ambient air temperature between 65.0 °F and 70.0 °F (18.3 °C and 21.1 °C) on a continuous basis for all types of consumer water heaters (and residential-duty commercial water heaters) other than heat pump water heaters. For heat pump water heaters, the dry-bulb (ambient air) temperature must be maintained between 67.5 °F ± 1 °F (19.7 °C ± 0.6 °C), and the relative humidity must be maintained at 50 percent ± 2 percent throughout the test. Appendix E does not specify a relative humidity tolerance for non-heat pump water heaters. Similar to the supply water temperature discussed previously, a brief measurement of air temperature or relative humidity that is only minimally outside of the test tolerance would invalidate a test, but likely would have a negligible effect on the results of the test, as the total time out of tolerance

would be insignificant compared to the total time of the test. In the April 2020 RFI, DOE requested feedback on whether the tolerances for ambient air temperature and relative humidity are difficult to maintain at the start of a draw, and if so, whether DOE should consider relaxing these requirements at the start of a draw and to what extent. 85 FR 21104, 21112 (April 16, 2020).

After considering comments received on the April 2020 RFI, DOE proposed in the January 2022 NOPR to change the ambient temperature requirement for non-heat pump water heaters to an average of 67.5 °F ± 2.5 °F, with a maximum deviation of 67.5 °F ± 5 °F, as opposed to only a maximum deviation of 67.5 °F ± 2.5 °F as currently specified in the test procedure. 87 FR 1554, 1578 (Jan. 11, 2022). DOE reasoned that such a change could, if adopted, reduce the need to re-run tests in instances in which the results of the invalid test and the valid test would not differ significantly, and, therefore, reduce test burden. *Id.* DOE also noted that through a review of its available test data, DOE found that short fluctuations in ambient temperature have little to no effect on the test results of non-heat pump water heaters. *Id.*

For heat pump water heaters, DOE proposed in the January 2022 NOPR to change the dry-bulb temperature requirement for heat pump water heaters to an average of 67.5 °F ± 1 °F during recoveries and an average of 67.5 °F ± 2.5 °F when not recovering, with a maximum deviation of 67.5 °F ± 5 °F, as opposed to only a maximum deviation of 67.5 °F ± 1 °F as currently specified in the test procedure. *Id.* DOE reasoned that this proposed change would maintain the stringency of the dry-bulb temperature requirement while allowing for short deviations from the targeted dry-bulb temperature range, which would reduce the need to re-run tests in instances in which the results of the invalid test and the valid test would not differ significantly, and, therefore, reduce test burden. *Id.*

For heat pump water heaters, DOE also proposed in the January 2022 NOPR to increase the absolute relative humidity tolerance from ± 2 percent to ± 5 percent across the entire test, with the average relative humidity between 50 percent ± 2 percent during recoveries. 87 FR 1554, 1578 (Jan. 11, 2022). DOE reasoned that this change, if adopted, would reduce test burden by reducing the need to re-run tests in instances in which the results of the invalid test and the valid test would not differ significantly. *Id.*

As noted, the currently applicable appendix E does not specify a relative

humidity tolerance for non-heat pump water heaters. In the January 2022 NOPR, DOE explained that (as initially described in the April 2020 RFI), DOE conducted exploratory testing to investigate the effect of relative humidity on the measured UEF values of two consumer gas-fired instantaneous water heaters that are flow-activated and have less than 2 gallons of storage volume, one using non-condensing technology and the other using condensing technology. 87 FR 1554, 1578 (Jan. 11, 2022). For each model, testing was performed at a relative humidity of 50 percent and at a relative humidity of 80 percent, and DOE found that increasing relative humidity from 50 percent to 80 percent resulted in a maximum change in UEF for the non-condensing and condensing models of 0.011 and 0.015, respectively. DOE noted that UEF is reported to the nearest 0.01 (see 10 CFR 429.17(b)(2)), and, thus, a change in UEF on the order of 0.01 to 0.02 as suggested by DOE's test results could be considered as substantively impacting the test results. However, DOE did not propose to adopt a tolerance on relative humidity in the January 2022 NOPR, noting that it was still examining this issue. DOE requested further comment and test data on whether a relative humidity requirement should be added to appendix E for non-heat pump water heaters. *Id.*

In response to the proposals made in the January 2022 NOPR concerning ambient air temperature and relative humidity tolerances, AHRI indicated its support of DOE's proposals to reduce test burden; specifically, AHRI supported increasing test tolerances for ambient temperature and relative humidity. (AHRI, Jan. 27, 2022 Public Meeting Transcript, No. 27 at p. 40) NEEA and CA IOUs suggested that DOE should specify a relative humidity level of 50 percent \pm 5 percent for all water heater types as was proposed for heat pump water heaters in the January 2022 NOPR, which the commenters argued would reduce test burden and ensure that results are comparable, repeatable, and representative across all products and technologies. (NEEA, No. 30 at pp. 1–2; CA IOUs, No. 36 at pp. 3–4)

BWC, however, anticipated difficulty maintaining even the proposed \pm 5 percent tolerance during compressor cycling for electric heat pump water heaters. BWC also argued that establishing a relative humidity tolerance when testing water heaters other than heat pump water heaters is unnecessary after observing low impact on UEF rating during its testing of a gas instantaneous water heater at both 20

percent relative humidity and 100 percent relative humidity. (BWC, No. 33 at p. 7) In response to BWC's comments, DOE notes that BWC has not provided, nor is DOE aware of, any data suggesting that a \pm 5 percent relative humidity tolerance would be difficult to maintain for heat pump water heaters.

After considering comments on the January 2022 NOPR, DOE is adopting the changes to ambient air temperature and relative humidity tolerances as proposed. Regarding the recommendation that DOE specify a relative humidity level of 50 percent \pm 5 percent for all water heater types, DOE finds that it does not have adequate test data to make such a change at this time, but DOE will continue to further investigate this issue.

5. Electrical Supply Voltage Tolerances

For all water heaters, section 2.7.1 of the currently applicable appendix E specifies maintaining the electrical supply voltage within \pm 1 percent of the center of the voltage range specified by the manufacturer. In the April 2020 RFI, DOE requested feedback on whether the tolerances for electrical supply voltage are difficult to maintain at the start of a draw, and if so, whether DOE should consider relaxing these requirements at the start of a draw and to what extent. 85 FR 21104, 21112 (April 16, 2020).

In the January 2022 NOPR, after considering comments received in response to the April 2020 RFI, DOE proposed to increase the electrical supply voltage tolerance from \pm 1 percent on a continuous basis to \pm 2 percent on a continuous basis. 87 FR 1554, 1577 (Jan. 11, 2022). DOE also proposed to add clarification that this tolerance is only applicable beginning 5 seconds after the start of a recovery to 5 seconds before the end of a recovery (*i.e.*, only when the water heater is undergoing a recovery). *Id.* DOE reasoned that these proposed changes could reduce test burden by reducing the need to re-run tests while maintaining the representativeness of the test procedure. *Id.*

In response to these proposed changes, DOE received comment from BWC supporting the proposal to increase the tolerance for electric supply voltage. (BWC, No. 33 at p. 7)

DOE has thus determined that the proposed changes to sections 2.7.1 and 3.7 of appendix E concerning electric supply voltage tolerance are appropriate and is adopting them in this final rule for the reasons previously stated.

6. Flow Rate Tolerances

Section 5.4.2 of appendix E, *Test Sequence for Water Heaters with Rated*

Storage Volumes Greater Than or Equal to 2 Gallons, provides that all draws during the 24-hour simulated-use test must be made at the flow rates specified in the applicable draw pattern table in section 5.5 of this appendix, within a tolerance of \pm 0.25 gallons per minute (\pm 0.9 liters per minute). Section 5.4.3 of appendix E, *Test Sequence for Water Heaters with Rated Storage Volume Less Than 2 Gallons*, currently does not provide explicit instruction for the tolerance on the flow rate.

Within the proposed amendments to the regulatory text provided in the January 2022 NOPR, DOE included a proposed amendment to section 5.4.3 of appendix E to specify that flow rates for water heaters with rated storage volume less than 2 gallons must be maintained within a tolerance of \pm 0.25 gallons per minute (\pm 0.9 liters per minute). 87 FR 1554, 1603 (Jan. 11, 2022). Because this proposed change was not addressed explicitly in the preamble to the January 2022 NOPR, DOE raised this issue again in the July 2022 SNOPR. 87 FR 42270, 42274 (July 14, 2022).

However, as discussed in the July 2022 SNOPR, there are models with Max GPM delivery capacities at or below 1.0 gallon per minute, and for these products, the flow rate used during draws must be the Max GPM flow rate. A flow rate tolerance of \pm 0.25 gallons per minute would be too wide for products with Max GPM flow rates as low as 0.20 gallons per minute. Because the flow rate tolerance represents 25 percent of the flow rate at 1.0 gallon per minute, DOE proposed another amendment to section 5.4.3 of appendix E in the July 2022 SNOPR to specify that for water heaters with a rated Max GPM of less than 1 gallon per minute, the flow rate tolerance shall be \pm 25 percent of the rated Max GPM. DOE reasoned that for such products, a flow rate tolerance \pm 25 percent of the rated Max GPM would represent the same level of variation (on a percentage basis) as for products rated at 1.0 gallon per minute and subject to a tolerance of \pm 0.25 gallon per minute. DOE noted that third-party laboratories are currently technically capable of implementing this methodology based on DOE's own test data. 87 FR 42270, 42274 (July 14, 2022).

In response to the July 2022 SNOPR, ASAP, ACEEE, and NRDC expressed support for DOE's proposal to specify the flow rate tolerance requirements for water heaters with a rated storage volume under 2 gallons. (ASAP, ACEEE, and NRDC, No. 54 at p. 1) BWC expressed they had not had adequate time to conduct testing in order to determine the impact of DOE's proposed

establishment of a ± 25 percent of maximum GPM threshold, and as a result, the company had no further comments on that proposal. (BWC, No. 48 at p. 2)

AHRI, A.O. Smith, and Rheem offered a few potential revisions to the proposal. AHRI requested that DOE set a minimum tolerance of ± 0.1 gpm for the 24-hour simulated-use test for models with maximum flow rates less than 1 gpm because the proposed ± 25 percent tolerance may be difficult to meet for some models. (AHRI, No. 55 at p. 2) A.O. Smith stated that the proposed flow rate tolerances for the 24-hour simulated-use test for water heaters with a rated storage volume less than 2 gallons would require manufacturers to invest in more precise equipment and may also easily invalidate results for units with low Max GPM values. Accordingly, A.O. Smith requested that DOE adopt the proposed flow rate tolerance from the NOPR, rather than the SNOPR. (A.O. Smith, No. 51 at pp. 2–3) Rheem indicated that the proposed flow rate tolerance of 25 percent of Max GPM may be too low for water heaters with very low max GPM and recommended that DOE change the tolerance to the maximum between that value and ± 0.1 gpm. Rheem also recommended that all flow rate tolerances be calculated based on the average of the flow rate over the entire draw, so as to help reduce the number of invalid tests. (Rheem, No. 47 at p. 2)

As discussed previously, the lowest Max GPM certified to DOE is currently 0.2 gpm, and DOE's amended test procedure must provide a reproducible and repeatable method for testing products with such low flow rates. DOE has determined that a tolerance of ± 0.1 gpm could offer too much variability in test results for products rated with such low flow rates. Specifically, a tolerance this wide would represent ± 50 percent of the flow rate of this kind of water heater, and because the temperature rise through the water heater is inversely related to the flow rate when the water heater is constantly firing at its maximum input rate, this variation in flow rate can cause the temperature rise to potentially double. As stated, DOE is aware that third-party laboratories are equipped with instrumentation to measure flow rates within the tolerance level proposed in the July 2022 SNOPR.

DOE did not receive any test data in response to the July 2022 SNOPR indicating that manufacturers or third party test laboratories would not be able to meet the tolerances proposed in the July 2022 SNOPR. Furthermore, DOE has concluded that a 0.1 gpm tolerance

is too large for the lowest flow rate models currently on the market (0.2 gpm) and would be even more problematic if models with flow rates below 0.2 gpm are introduced in the future. As such, in this final rule, DOE is adopting the flow rate tolerance amendments to sections 5.4.2 and 5.4.3 of appendix E, as proposed in the July 2022 SNOPR.

7. Optional Test Conditions for Heat Pump Water Heaters

In the course of this rulemaking, DOE has received numerous comments from stakeholders requesting that DOE consider allowing manufacturers to optionally rate heat pump water heaters to test conditions other than those currently specified in appendix E, which are intended to be representative of national average water and air temperatures. Commenters noted that heat pump operation is dependent upon the surrounding ambient air temperatures,⁵² and that there would be significant value to providing consumers, installers, and utilities with efficiency representations that are closer to the conditions for particular climates. See 87 FR 1554, 1580 (Jan. 11, 2022) and 87 FR 42270, 42275–42276 (July 14, 2022).

For example, Lutz commented that a single inlet water temperature may not be representative for all cases because this may vary by geographical location, and, furthermore, that taking this into account is even more important for split-system heat pump water heaters with an outdoor unit. (Lutz, No. 35 at p. 1) NEEA argued that, because heat pump water heater performance can be affected by variations in ambient conditions, DOE should clarify what manufacturers can report about a unit's performance at conditions other than those required by the test procedure. NEEA added that information regarding delivery capacity and sizing guidance would be important for installers. (NEEA, No. 30 at p. 3)

In the January 2022 NOPR, DOE did not propose to allow for optional (voluntary) representations of heat pump water heater efficiencies at non-standard temperatures because there

⁵² Because heat pumps “transfer thermal energy from one temperature level to a higher temperature level” (see 42 U.S.C. 6291(27)(C) and 10 CFR 430.2), the energy efficiency is dependent upon the difference between temperatures that must be overcome by the heat pump cycle. As discussed in section III.A.2 of this document, heat pump water heaters are typically air-source, *i.e.*, these products source heat from surrounding air and transfer it to domestic hot water. Therefore, lower ambient air temperatures, such as those experienced in colder climates or due to seasonal differences, would result in lower efficiencies.

was not enough information at the time to identify the most representative alternate test conditions (*e.g.*, regional conditions). 87 FR 1554, 1580 (Jan. 11, 2022). However, commenters on the July 2022 SNOPR identified the NEEA Advanced Water Heating Specification (currently at version 8.0, AWHS v8.0) provides multiple conditions which manufacturers are providing ratings at. 87 FR 42270, 42275–42276 (July 14, 2022). Consequentially, DOE revisited the NEEA Advanced Water Heating Specification to determine how the test conditions specified in that document might be applied for optional representations in the DOE test procedure.

Section 2.2 of appendix E currently specifies that the ambient air temperature shall be maintained between 65.0 °F and 70.0 °F (18.3 °C and 21.1 °C) on a continuous basis during the test. Additionally, for heat pump water heaters, that test procedure provision provides that the dry-bulb temperature shall be maintained at 67.5 °F ± 1 °F (19.7 °C ± 0.6 °C) and that the relative humidity shall be maintained at 50 percent ± 2 percent throughout the test. EPCA requires that the DOE test procedure must be reasonably designed to produce test results which measure energy efficiency during a representative average use cycle or period of use. (42 U.S.C. 6293(b)(3)) While the test conditions in the current appendix E test procedure must remain representative for the nation as a whole, in the July 2022 SNOPR, DOE tentatively determined that comments from interested parties have demonstrated that allowing additional representations of efficiency at alternative ambient conditions could provide consumers with additional information about the expected performance of heat pump water heaters at conditions that are representative of their specific installation circumstances. For other types of covered products and equipment, DOE has adopted optional metrics for voluntary representations where it was determined that the primary efficiency metric would not be representative for certain installation conditions common for the product or equipment.⁵³ As discussed in the July

⁵³ For example, on July 27, 2022, DOE published a final rule in the **Federal Register** pertaining to test procedures for direct-expansion dedicated outdoor air systems, including provisions for optional representations of energy efficiency when the equipment is installed in applications where inlet water conditions are expected to deviate substantially from standard conditions. See 10 CFR part 431, subpart F, appendix B, section 2.2.3(d) as established by that final rule. 87 FR 45164, 45201 (July 27, 2022).

2022 SNOPI, depending on the installation location (*e.g.*, whether the water heater is installed in an unconditioned space such as a garage or attic), the ambient conditions may vary significantly from the conditions in the DOE test method, thereby resulting in significantly different performance for heat pump water heater products. Thus, DOE reversed its position and tentatively determined to allow for certain optional representations for additional ambient conditions. 87 FR 42270, 42275–42276 (July 14, 2022).

AWHS v8.0 was published by NEEA on March 1, 2022. Though early editions of the AWHS focused primarily on providing more representative performance metrics for heat pump water heaters in cold climates, the latest editions are now more broadly focused on providing representative performance metrics for heat pump water heaters across all climates. Performance metrics in the AWHS are generally calculated by measuring energy efficiency at multiple (two or more) ambient test conditions, linearly interpolating between the test results, and finally calculating an ambient temperature-weighted efficiency metric using temperature bin data. The metric is a cold climate efficiency (CCE) rating for integrated heat pump water heaters installed in semi-conditioned spaces (*i.e.*, garage, basement) and a seasonal coefficient of performance (SCOP) for split-system heat pump water heaters (where the heat pump is separated from the storage tank and located outdoors). DOE tentatively determined in the July 2022 SNOPI that adopting the test conditions in AWHS v8.0 would not significantly increase test burden for manufacturers who choose to provide these ratings, because manufacturers are already providing representations of CCE and SCOP to NEEA's Qualified Products List.⁵⁴ The test conditions in AWHS v8.0 differ from the standard conditions in appendix E in terms of inlet water temperature, ambient dry-bulb temperatures, and ambient relative humidity. A detailed discussion of these conditions was provided in the July 2022 SNOPI. 87 FR 42270, 42276 (July 14, 2022).

In the July 2022 SNOPI, DOE proposed to allow voluntary representations of a new metric, E_x , analogous to UEF, at optional test conditions for heat pump water heaters. The subscript “X” would be used to denote the set of conditions being used, and these voluntary representations of

E_x would not be integrated together to form a seasonal efficiency metric—in contrast to the methodology in AWHS v8.0. DOE's proposal intended to eliminate any reduction in representativeness caused by assumptions in climate weighting factors. Without substantial additional data, DOE tentatively determined that it would not be able to evaluate whether or not the weighting factors in AWHS v8.0 (used to create a weighted average of the results at various test conditions together into one metric, CCE or SCOP) are representative of climates in the United States, and, thus, DOE proposed to allow for the use of standalone E_x representations only in a way that it is clear to a consumer what test conditions were used in determining the rating. 87 FR 42270, 42276–42277 (July 14, 2022).

In response to the July 2022 SNOPI, ASAP, ACEEE, and NRDC expressed support for DOE's proposal to adopt optional test conditions needed for calculating climate-specific efficiencies. (ASAP, ACEEE, and NRDC, No. 54 at p. 2) A.O. Smith acknowledged that optional efficiency ratings may have consumer utility and stated that additional measures of efficiency may assist with increasing market adoption of heat pump water heaters. (A.O. Smith, No. 51 at pp. 3–4) The CA IOUs supported DOE's tentative determination to allow optional efficiency representations at multiple test conditions for heat pump water heaters, stating that this change will help consumers choose the heat pump water heater that best suits their needs and will aid in the maturation and expansion of the heat pump water heater market. (CA IOUs, No. 52 at pp. 1–2)

NEEA also supported DOE's proposal to allow for optional efficiency representations at alternative ambient conditions for heat pump water heaters but encouraged DOE not to limit condition representations based on the specific type of heat pump. NEEA stated that both split-system water heaters and heat pump-only water heaters can be designed for any combination of indoor, outdoor, and semi-conditioned space operation of the heat pump component. Therefore, NEEA suggested that DOE should not specify which metrics may be reported on the basis of heat pump type, as these additional representations would not add any burden to manufacturers because they are optional. (NEEA, No. 56 at pp. 1–2)

A.O. Smith requested that DOE clarify whether manufacturers may represent optional metrics as consistent with appendix E. (A.O. Smith, No. 51 at pp. 3–4)

In response to NEEA's comment, DOE acknowledges that split-system and heat pump-only water heaters may be installed in a variety of configurations which can vary the location of components. For example, a heat pump module (comprised of the compressor, evaporator, and expansion devices) could be installed either outdoors or in a separate room indoors. Therefore, DOE has updated the table of optional test conditions in section 2.8 of appendix E to reflect this fact by allowing split-system and heat pump-only water heaters to be tested at the conditions specified for any E_x . In response to NEEA and A.O. Smith, DOE notes that manufacturers will be able to represent optional metrics as specified in the amended appendix E.

Rheem stated that the Code of Federal Regulations only allows voluntary ratings for distribution transformers and commercial pre-rinse spray valves. Rheem also stated that the 24-hour simulated-use test for water heaters is more complex and very different from those specified for these other types of equipment which, according to Rheem, have test procedures that easily handle testing at alternate conditions. (Rheem, No. 47 at pp. 2–3)

In response to Rheem's comment, DOE notes that optional additional test conditions are being adopted in appendix E because industry has already demonstrated its desire for them through testing at specific conditions in compliance with NEEA Advanced Water Heating Specification v8.0. By amending appendix E to include these conditions, DOE is simply standardizing current industry practices. Because ratings at such conditions are voluntary, DOE anticipates that there would be no undue burden associated with adoption of such provisions in this final rule.

DOE also notes that water heaters are used in a variety of conditions and are expected to operate at all times despite them. This sets water heaters apart as compared to what is expected of other products (*e.g.*, air conditioners), which are only active and operate in response to specific conditions. Test procedures for these products already include a range of conditions, and, therefore, they do not require optional representations of performance. For these other types of products, the range of conditions experienced would be narrower and more predictable than the range of conditions experienced by heat pump water heaters,⁵⁵ and, therefore, it is not

⁵⁴ Available at: [needa.org/img/documents/residential-unitary-HPWH-qualified-products-list.pdf](https://www.needa.org/img/documents/residential-unitary-HPWH-qualified-products-list.pdf) (Last accessed on May 11, 2022).

⁵⁵ For example, Table 11 in section 3.6.1 of appendix M1 to subpart B of 10 CFR part 430 provides the heating mode test conditions for central (space-conditioning) heat pumps having a

unduly burdensome to require testing at multiple conditions for these other types of products. The narrower range of air conditions also ensures that the results of testing are highly representative of the product's average performance. This is not the case for heat pump water heaters because of the many different installation configurations which are applicable to heat pump water heaters—for instance, some are located indoors, and some are located outdoors. Allowing testing at these conditions to be optional avoids burdening manufacturers with test conditions that may not apply to their products. Using a different metric (E_x) for these conditions also ensures that these representations are not read as being valid for all consumer applications; instead, the representation is specific to the condition at which the water heater is being tested.

AHRI, BWC, and Rheem suggested that allowing optional ambient test conditions may increase manufacturer burden, arguing that they may eventually be driven by the market to conduct such testing. (AHRI, No. 55 at p. 3; BWC, No. 48 at p. 2; Rheem, No. 47 at p. 3) BWC also stated that not all manufacturers are currently conducting testing per NEEA Advanced Water Heating Specification v8.0, and that DOE allowing optional testing based on its test conditions would cause significant burden. (BWC, No. 48 at p. 2) Rheem requested that DOE either adopt the position from the last test procedure rulemaking that requiring additional testing at alternate conditions is unduly burdensome or provide justification for why it is not. (Rheem, No. 47 at p. 3) AHRI indicated that third-party laboratories may not be equipped to perform the optional tests at additional ambient conditions because of how the test set-up differs from that used in the standard test and that large capital burdens would need to be incurred in order to comply. AHRI also expressed concern that DOE did not adequately solicit manufacturer and laboratory feedback on increased test burden due to the proposed optional additional ambient test conditions. (AHRI, No. 55 at p. 4) Rheem also stated that optional tests currently performed by manufacturers are not necessarily

single-speed compressor and a fixed-speed indoor blower. The range of temperatures at which the outdoor evaporator coil can be tested is from 5 °F at the lowest to 47 °F at the highest. Because a heat pump water heater would also be active during the summer months, DOE has determined that the representative range of outdoor ambient temperatures for a split-system heat pump water heater's outdoor evaporator coil could be from 5 °F at the lowest to 95 °F at the highest.

done to be in accordance with AWHs and that NEEA, an entity which is not a manufacturer, distributor, retailer, or private labeler, was not restricted from making representations of products based on testing which did not use the DOE test procedure. (Rheem, No. 47 at pp. 2–3)

In response to these comments, DOE disagrees that optional testing will increase manufacturer burden for a number of reasons. First, as previously discussed in the July 2022 SNOPR, DOE is currently aware of 17 water heater brands represented in the Qualified Products List for AWHs v8.0. Participation in NEEA's program using Advanced Water Heating Specification v8.0 requires manufacturers to submit their own test results at the prescribed test conditions; NEEA does not appear to perform testing on behalf of manufacturers, per its own documentation.⁵⁶ Most importantly, DOE reiterates that this testing is ultimately optional, so a manufacturer may decline to undertake any additional testing. Consequently, DOE has concluded that allowing optional additional testing conditions will not increase burden for manufacturers.

BWC claimed that DOE is not authorized under EPCA to allow manufacturers to have additional optional representations of performance and requested that DOE clarify its statutory authority. (BWC, No. 48 at p. 2) Rheem claimed that justifications for other products allowing optional additional ratings do not apply to consumer water heaters and stated that EPCA⁵⁷ can be interpreted as prohibiting optional additional test conditions that are not in the test procedure.

In response to these comments, DOE finds BWC's and Rheem's interpretations of 42 U.S.C. 6293(c) to be misguided. The statute requires appliance efficiency testing and representations to be done in accordance with the DOE test procedure. DOE routinely incorporates by reference private sector testing methods into Federal test procedures, and nothing in the statute would prohibit adoption of optional test conditions as these commenters suggest.

⁵⁶ Steps in the process flow for NEEA's AWHs Qualified Products List can be found online at: www.neea.org/img/documents/qualified-products-process-flow.pdf (Last accessed on Sept. 10, 2022).

⁵⁷ The commenter cited 42 U.S.C. 6293(c), "Restriction on Certain Representations," of which subsection (1) prohibits representations not made in accordance with the currently applicable test procedure and subsection (2) prohibits representations not made in accordance with a new or amended test procedure 180 days after the adoption of that test procedure.

DOE notes that the optional conditions at which manufacturers may choose to test their products are specified as part of the AWHs v8.0 test procedure and are not left up to manufacturers to determine individually. Precisely by including these optional conditions and metrics in the appendix E test procedure, DOE is permitting manufacturers and other parties to make such representations to the public in the manner which the statute contemplates. EPCA requires that a uniform efficiency metric (*i.e.*, UEF) be used to rate all water heaters; however, the addition of optional representations does not prevent manufacturers from making its mandatory UEF rating under the required conditions. By virtue of the new heat pump water heater testing and metric being optional, DOE would not enforce the required energy conservation standard based upon results of testing at optional test conditions. Permitting testing under the specified optional conditions may also serve another purpose. In a future rulemaking considering further amendments to the appendix E test procedure, DOE may consider adopting multiple ambient test conditions for certain types of water heaters, if data from testing at these additional conditions proves that this methodology yields results more representative of energy consumption over an average use cycle. Hence, allowing manufacturers to test and rate these optional conditions would allow more data to be collected for potential future amendments.

AHRI requested that DOE provide any data justifying the proposal to include optional ambient test conditions to stakeholders. (AHRI, No. 55 at pp. 2–3) BWC requested that DOE readopt its position that there is insufficient data to support optional additional ambient test conditions and to provide the data that caused DOE to make this proposal in the SNOPR. (BWC, No. 48 at p. 2)

In response, DOE notes that NEEA's Qualified Products List⁵⁸ indicates the climate-weighted average performance of heat pump water heaters as tested by manufacturers to the various conditions in AWHs v8.0. (This performance metric, "cool climate efficiency," is a result of testing under the optional conditions which DOE is adopting in this final rule.) From the data points in NEEA's Qualified Products List, manufacturers demonstrate that heat pump water heaters are less energy-efficient at these additional conditions. For example, Tier 4 products, which

⁵⁸ Available at: www.neea.org/img/documents/residential-unitary-HPWH-qualified-products-list.pdf (Last accessed on Sept. 18, 2022).

range in UEF from 3.45 to 4.02 at DOE's required test conditions, have cool climate efficiencies ranging from 3.1 to 3.5. These ratings have been provided to NEEA by manufacturers conducting their own testing. While DOE is not adopting the cool climate efficiency metric (because it requires testing at *all* of the additional ambient conditions, and that would significantly increase burden for a manufacturer wanting to provide consumers with additional ratings), these cool climate efficiency ratings are an objective indication of how performance can be impacted by varying climatic conditions. By adopting E_x optional ratings in appendix E, DOE expects to facilitate manufacturer testing and the generation of relevant data related to water heater performance at these additional conditions. Again, the standardized voluntary ratings could be considered in a future rulemaking to determine the representativeness of the current mandatory ambient conditions in appendix E.

AHRI also stated that DOE has not provided evidence that NEEA's AWHs test conditions ensure repeatability and reproducibility and suggested that these requirements still apply even if the procedure is optional. (AHRI, No. 55 at p. 4)

Repeatability refers to the quality of a test method which allows a laboratory to achieve the same results when a product is tested on more than one occasion. Reproducibility refers to the quality of a test method which allows one laboratory to reproduce the results obtained by another laboratory. Test tolerances and set-up requirements are essential to these parameters. As proposed in the July 2022 SNO PR and adopted in this final rule, the optional test conditions would be tested per the same tolerances and set-up requirements as the current UEF test procedure—simply at different temperatures. Utilization of this Federal testing framework makes it possible for DOE to ensure that the voluntary ratings of E_x are repeatable and reproducible.

AHRI stated that DOE has not provided references to other occasions when it has adopted optional metrics for voluntary representations for other products or equipment. (AHRI, No. 55 at p. 4) AHRI requested that DOE remove the proposal concerning optional additional ambient test conditions from this rulemaking and instead address it in a subsequent rulemaking for these products. (AHRI, No. 55 at p. 4)

In response and as discussed earlier in this section, DOE has previously adopted optional metrics for voluntary representations where there was a clear

industry precedent for these metrics and a consumer utility for having the additional performance information. Most recently, this was done for dedicated outdoor air systems (DOASes). For heat pump water heaters, there is a clear indication that industry wishes to provide consumers with these additional ratings because numerous product representations have been submitted by several manufacturers to NEEA for its Qualified Products List. DOE's amendment to officially adopt these supplemental test conditions into the appendix E test procedure ensures that when these representations are provided, they are done so based on a consistent test method.

Rheem stated that it has not had enough time to evaluate DOE's proposal to allow optional additional test conditions. (Rheem, No. 47 at p. 2) Rheem requested that DOE clarify the sampling, certification, and enforcement provisions for heat pump water heaters with alternate representations. (Rheem, No. 47 at p. 3)

In response, DOE notes that it provided a three-week comment period on the limited set of issues presented in the July 2022 SNO PR, and other commenters were able to assess DOE's latest proposal and provide substantive comments during the time allotted. By virtue of E_x being an optional metric for voluntary representations, DOE will not require certification of E_x representations. Manufacturers who opt to determine E_x must apply the sampling requirements for determining UEF in order to ensure consistency in values provided to consumers.

Rheem recommended that DOE fully evaluate the alternate conditions specified in AWHs before adopting them. (Rheem, No. 47 at p. 4) Rheem stated that it has not had time to fully evaluate the alternate test conditions and questions whether they adequately represent the entire Nation, or only represent the Northwest, as these test conditions were developed by NEEA. (Rheem, No. 47 at p. 4)

To clarify, by allowing manufacturers to make separate E_x representations for each set of test conditions, the voluntary representations, individually, are not designed to be representative of the entire United States. To do so would require these test conditions to be averaged together based on prevalence of climate conditions at a given location, and this aspect of NEEA's AWHs v8.0 is not being used in the appendix E optional representations. Instead, it is DOE's mandatory testing scenario—the determination of UEF through the standard rating conditions—that is intended to reflect average conditions

for the Nation as a whole. DOE has evaluated the full set of test conditions NEEA specifies in AWHs v8.0 and has determined that these conditions are meant to cover the full range of operating conditions (temperature and humidity) possible across the United States. They are not meant to only represent the range of conditions possible in the Northwestern United States. The purpose of E_x representations, as employed by DOE at appendix E, is to indicate performance at individual rating points, which, along with UEF, will provide additional information to consumers. Manufacturers will be permitted to make voluntary representations at any of the optional test conditions specified in appendix E.

BWC stated that DOE's proposal to allow optional additional test conditions would confuse consumers and installers because they may not have the means to sufficiently assess environmental conditions where they live. (BWC, No. 48 at p. 3) In addition, BWC commented that allowing optional additional test conditions may cause scarcity of testing resources, thereby significantly increasing manufacturer burden. (BWC, No. 48 at p. 3)

DOE disagrees with BWC's presumption that consumers and installers cannot assess environmental conditions. These parties may easily access a variety of sources of freely available weather data, such as information generated by the National Oceanic and Atmospheric Administration (NOAA) and the National Weather Service (NWS).^{59 60} In addition, installers of central air conditioning, central heat pump, and cool-climate heat pump units already have sufficient access to local environmental data required to install them. These data are the same data required for the installation of water heaters. Although DOE understands BWC's concern regarding limited testing resources, DOE once again reiterates that this testing is ultimately optional; manufacturers are not obligated to make capital investments or dedicate testing resources if it is not feasible. To the extent that optional testing would

⁵⁹The National Weather Service (NWS) maintains a Climate page on their website which provides past weather records and climate information for regions of the United States and its territories. This page is available at: www.weather.gov/wrh/climate. (Last accessed Sept. 28, 2022)

⁶⁰The National Centers for Environmental Information (NCEI) maintains a Past Weather page with past weather data from weather stations around the world. This data is available for download in various file formats. This page is available at: www.ncei.noaa.gov/access/past-weather/. (Last accessed Sept. 28, 2022)

utilize resources that would otherwise be used for mandatory testing, DOE notes that manufacturers would have the option of foregoing or delaying optional testing to accommodate mandatory testing since DOE is not requiring use of any of the optional test conditions. Furthermore, as manufacturers have already provided ratings to NEEA at these alternate conditions, DOE does not believe that officially adopting these test conditions would change overall available laboratory capacity, especially as manufacturers may opt to test these optional conditions in-house.

ASAP, ACEEE, and NRDC requested that DOE clarify which optional test conditions would apply to split-system water heaters with an indoor heat pump component. (ASAP, ACEEE, and NRDC, No. 54 at p. 2) In response, DOE notes that the included optional test conditions are intended to be used at the discretion of the manufacturer. Manufacturers are free to use the conditions specified by the test points they believe are most similar to what their product may experience during operation. For example, a manufacturer of a split-system heat pump water heater whose compressor and storage tank are located outdoors and indoors, respectively, may decide it would be beneficial to evaluate the product's performance at an outdoor ambient temperature of 34.0 °F. In this case, the manufacturer would test the product using the conditions specified by the E_{34} metric: outdoor dry-bulb temperature and relative humidity of 34.0 °F and 72 percent, respectively, indoor dry-bulb temperature and relative humidity of 67.5 °F and 50 percent, respectively, and supply water temperature of 47.0 °F.

Rheem requested that DOE evaluate wider tolerance ranges for the alternate test conditions. Rheem also asked that DOE clarify whether relative humidity control is required for storage tanks during split-system water heater tests, in which case, the commenter argued that two psychrometric chambers would be required. (Rheem, No. 47 at pp. 3–4)

In response, DOE notes that the amendments being adopted for ambient condition tolerances during UEF testing would also apply to E_x testing, hence allowing a similarly wider tolerance range to apply at all conditions. When testing a split-system heat pump water heater or heat pump water heater requiring a separate storage tank, the heat pump portion of the system shall be tested at the relative humidity conditions specified, and the storage tank can be tested at either the same conditions or the conditions specified in section 2.2.1 of appendix E. Thus, the

relative humidity control is not required for the storage tank during split-system water heater tests. This is discussed further in section III.D.1 of this document.

Rheem requested that DOE remove “heat pump only” from the table of alternate test conditions because they are the same as the outdoor portion of a split-system water heater. (Rheem, No. 47 at p. 4)

In response, DOE wishes to make clear that circulating heat pump water heaters (heat pump-only water heaters) and split-system water heaters are not identical. Circulating heat pump water heaters are instantaneous-type units, whereas split-system heat pump water heaters have a storage tank and are, overall, storage-type units. Both types of products may have the heat pump module located remotely from the storage tank, but still indoors. In light of this comment, DOE has modified the table of alternate test conditions to explicitly allow split-system and circulating heat pump water heaters to be tested at any of the conditions specified.

D. Test Set-Up and Installation

1. Split-System Heat Pump Water Heaters

In section III.A.2 of this document, DOE discussed a new definition for this subset of heat pump water heaters. As established by this final rule, a “split-system heat pump water heater” means a heat pump-type water heater with an indoor storage tank and outdoor heat pump component. In considering such products, DOE had found that in a split-system heat pump, the heat pump part of the system is typically installed outdoors and, as a result, does not use the indoor ambient air for water heating directly. In the current appendix E test procedure, different ambient conditions are specified in appendix E for heat pump water heaters and non-heat pump water heaters, but there are no specific conditions for split-system heat pump water heaters.

In the January 2022 NOPR, DOE proposed to specify that the heat pump part of the system shall be tested using the heat pump water heater dry-bulb temperature and relative humidity requirements, while the storage tank part of the system shall be tested using the non-heat pump water heater ambient temperature and relative humidity requirements. DOE noted that the required non-heat pump water heater ambient conditions can be met by keeping the entire system within the dry-bulb temperature and relative humidity requirements for heat pump

water heaters (*i.e.*, both parts of the system can be tested in the same psychrometric chamber). 87 FR 1554, 1583 (Jan. 11, 2022).

On this topic, AHRI requested that DOE clarify whether the proposed testing requirements for split-system heat pump water heaters would mean testing would have to be carried out with the heat pump and storage tank in separate rooms. (AHRI, Jan. 27, 2022 Public Meeting Transcript, No. 27 at p. 42) NYSERDA indicated that DOE should collaborate with manufacturers to ensure that test conditions and set-up for split-system heat pump water heaters are consistent, repeatable, and not burdensome. (NYSERDA, No. 32 at p. 4) BWC suggested that DOE should permit manufacturers and testing laboratories as much flexibility as possible when determining the testing locations of separate system components and not prevent test set-ups that can meet the specified conditions for both systems in the same room or area, if a manufacturer or test laboratory so chooses. (BWC, No. 33 at p. 9) Rheem requested clarification that the storage tank can be tested at the heat pump test conditions and still meet the requirements of appendix E. (Rheem, No. 31 at p. 3)

To reiterate DOE's explanation in the January 2022 NOPR, if a single room, chamber, or area is capable of meeting the dry-bulb temperature and relative humidity requirements for heat pump water heaters, then, like integrated heat pump water heaters, split-system heat pump water heaters can be tested with both indoor and outdoor components in the same space. In response to NYSERDA, by adopting this approach, DOE is aligning with the methodology used already by industry when testing heat pump water heater products for other representations (such as the Qualified Products List for NEEA's AWHs v8.0), so consequently, DOE expects the results generated to be consistent, repeatable, and not unduly burdensome.

2. Mixing Valves

As discussed in section III.E.1 of this final rule, there are certain water heater designs which raise the temperature of water stored in the tank significantly above the outlet water temperature, and these products are meant to be used with a mixing valve (which may or may not be provided with or built-in to the unit) so that the hot stored water can be tempered down to a more typical delivery temperature. The January 2022 NOPR noted that the installation instructions in section 4 of appendix E do not address cases when a separate

mixing valve should be installed. 87 FR 1554, 1580 (Jan. 11, 2022).

The January 2022 NOPR proposed to incorporate instructions for separate mixing valve installations based on those found in the ENERGY STAR Test Method to Validate Demand Response for Connected Residential Water Heaters (ENERGY STAR Connected Test Method) (published on April 5, 2021). This set-up requires installing the mixing valve in accordance with the water heater and mixing valve manufacturer's instructions. Absent instruction from the water heater or mixing valve manufacturer, the mixing valve is to be installed in the outlet water line, upstream of the outlet water temperature measurement location, with the cold water supplied from a tee installed in the inlet water line, downstream of the inlet water temperature measurement location (*i.e.*, the mixing valve and cold water tee are installed within the inlet and outlet water temperature measurement locations). Section 4.1 of the ENERGY STAR Connected Test Method further clarifies that if the liquid flow rate and/or mass measuring instrumentation is installed on the outlet side of the water heater, that it shall be installed after the mixing valve. 87 FR 1554, 1580 (Jan. 11, 2022).

On July 18, 2022, EPA published the ENERGY STAR Connected Residential Water Heaters Test Method to Validate Demand Response, Version 1.2.⁶¹ The updated test method retains the same instructions for setting up mixing valves in section 4.1.

In response to the January 2022 NOPR, ASAP, ACEEE, and NCLC; AET; A.O. Smith; and the CA IOUs supported DOE's proposal to include instructions for the installation of a mixing valve. (ASAP, ACEEE, and NCLC, No. 34 at pp. 1–2; AET, No. 29 at p. 2; A.O. Smith, No. 37 at p. 4; CA IOUs, No. 36 at p. 4) A.O. Smith also commented that, depending on the design, there may be additional steps that are required (*e.g.*, independently adjusting the tank thermostat and the mixing valve settings to remain in default mode per the manufacturer's instructions), and, therefore, DOE should clarify the details of this procedure. (A.O. Smith, No. 37 at p. 4)

In this final rule, DOE is adopting the proposed installation instructions for mixing valves as discussed in the January 2022 NOPR. To the extent that there may be additional steps required to maintain normal operation with the

mixing valve installed per the manufacturer's specifications, these instructions would be heeded in accordance with section 4.3 of the amended appendix E test procedure. As described in section III.E.1 of this document, DOE is also providing an optional test method for high storage tank temperature operation, and this test method involves the installation of mixing valves for products which do not come so equipped.

3. Flow Meter Location

The current test procedure does not specify where in the flow path the flow volume and density of water must be measured, and this allows for laboratory test set-ups to perform these measurements either on the cold/inlet side of the water heater or on the hot/outlet side. As discussed in this rulemaking, water mass calculations can account for the difference in the density of water at the inlet vs. the outlet (colder water at the inlet has a higher density); however, there could be cases when a measurement based on the inlet location could result in inaccurate mass calculations. Specifically, some of the mass of inlet water could, after being heated, expand out of the water heater into the expansion tank and be purged prior to a draw. Any "expanded" volume of water that is lost through the bypass (purge) line could be included in a volume measurement taken at the inlet, but not be included in a volume measurement taken at the outlet. 87 FR 1554, 1581 (Jan. 11, 2022). The Department requested information and data regarding the issue of flow meter location (inlet vs. outlet) in the April 2020 RFI and the January 2022 NOPR. 85 FR 21104, 21113 (April 16, 2020); 87 FR 1554, 1581 (Jan. 11, 2022).

In response to the April 2020 RFI, four commenters either disagreed with requiring the flow meter to be located at the outlet or requested that DOE continue to allow facilities to choose the location, whereas two commenters stated that the flow rate should be measured at the outlet of the water heater, expressing concern that measuring at the inlet may be inaccurate. 87 FR 1554, 1581 (Jan. 11, 2022). The January 2022 NOPR presented DOE's exploratory test data evaluating the effect of flow meter location on the water mass measurement (see Table III.2 of the January 2022 NOPR). DOE's testing using Coriolis flow meters on both the inlet and outlet water lines indicated that more accurate measurements of the mass of water delivered are obtained when the flow meter is located in the outlet water line than when located on

the inlet line, when both results were compared to a mass scale.⁶² In particular, the error in the UEF resulting from a mass measurement from a flow meter at the outlet ranged between 0.002 and 0.016, whereas the error in the UEF resulting from a mass measurement from a flow meter at the inlet ranged between 0.023 and 0.029, depending on the type of water heater (with DOE testing both gas-fired storage and gas-fired instantaneous water heaters). DOE also acknowledged that third party laboratories typically install a flow meter on the inlet side. However, DOE did not propose a change based on this limited set of test results, which only included one gas-fired storage water heater sample and one gas-fired instantaneous water heater sample, and stated that more test data are required. *Id.* at 87 FR1581–1582.

In response to the NOPR's request for information on this issue, AHRI stated that having the flow meter at the inlet of the water heater avoids having debris damage the flow meters (*e.g.*, Teflon tape debris from the test rig can end up in the flow meter and cause damage). In addition, AHRI commented that placing the flow meter at the outlet may cause water mass calculation problems, because the temperature variation is greater at the outlet, and flow meters may not be designed to withstand these higher outlet water temperatures. Therefore, AHRI indicated it would support the option of installing a flow meter at the inlet. (AHRI, No. 40 at p. 2) Rheem once again noted that major third-party testing laboratories have flow meters installed at the inlet of the water heater and that it is likely that all certified models have been tested with such a set-up. (Rheem, No. 31 at pp. 4–5) BWC commented that manufacturers should still have the option to install flow meters at the inlet to ensure accurate results and longevity of testing equipment, as well as to avoid manufacturer burden. Specifically, BWC indicated that manufacturers may have sophisticated set-ups with flow meters installed at the inlet, and there could be substantial burden with overhauling these set-ups. (BWC, No. 33 at p. 8)

Based on these comments, DOE has determined that a requirement for flow meters to be installed at the outlet may not only require re-testing a large number of basic models but also

⁶² Mass of water drawn from the water heater can either be directly measured using a mass scale, or it can be calculated by using a flow meter to measure the volume of water moved (and converted to mass using the density of the water). The mass scale approach represents the actual value of the mass of water drawn, against which the flow meter results can be compared.

⁶¹ Available at: www.energystar.gov/products/spec/residential_water_heaters_specification_version_5_0_pd (Last accessed on July 25, 2022).

potentially degrade the reliability of the testing rig due to debris flowing downstream. Because there is a generally consensus among stakeholders who commented on this issue that it is necessary to retain the ability to install the flow meter at the inlet side, DOE is not amending appendix E to require measurement at the outlet side. Instead, DOE is maintaining its current provisions in sections 3 and 4 of appendix E, which allow for the flow meter to be installed on either the inlet or outlet side.

4. Separate Storage Tanks

Some water heaters on the market require a volume of water, typically contained in either a storage tank (or tanks) or in a piping distribution system of sufficient volume, to operate. These products operate by circulating water stored either in the piping system or from a separate tank (or multiple separate tanks) to the water heater to be heated then back to the piping system or tank until hot water is needed. As discussed in section III.A.4.a of this document, DOE is adopting a definition for these products, which are termed “circulating water heaters.” In the January 2022 NOPR, DOE identified two types of circulating water heater products that require a volume of water to operate—heat pump-only water heaters that require installation with a separate storage tank and circulating gas-fired instantaneous water heaters that require installation with a separate storage tank or a piping system of sufficient volume. 87 FR 1554, 1583–1585 (Jan. 11, 2022). Circulating gas-fired instantaneous water heaters are distinct from other types of gas-fired instantaneous water heaters in that they are not designed to operate independent of a storage tank or hot water system, as other gas-fired instantaneous water heaters are. This applies generally to circulating water heaters; however, DOE has determined that there are no electric resistance or oil-fired circulating water heaters on the market today.

The currently applicable appendix E test procedure does not have procedures in place to appropriately test circulating water heaters. In the January 2022 NOPR, DOE proposed to require that circulating water heaters be tested using an 80 gallon (± 1 gallon) unfired hot water storage tank (UFHWST) that meets the energy conservation standards for an unfired hot water storage tank at 10 CFR 431.110(a). 87 FR 1554, 1583–1585 (Jan. 11, 2022).

In response to the January 2022 NOPR, DOE received a number of comments regarding the separate storage tank requirements, primarily related to

the ± 1 gallon tolerance, the representativeness of an 80-gallon unfired hot water storage tank, and the lack of a specification of an upper bound on thermal insulation for the unfired hot water storage tank. These comments were discussed in detail and addressed in the July 2022 SNO PR. Some commenters specifically recommended that DOE specify electric storage water heaters to be paired with heat pump-only water heaters. Commenters also raised questions as to whether or not the separate tanks to be used during testing may have back-up heating. For gas-fired circulating water heaters, commenters urged DOE to consider allowing multiple tank sizes to be used for testing rather than just the 80-gallon tank proposed in the January 2022 NOPR. 87 FR 42270, 42281–42283 (July 14, 2022).

After considering the issues raised by commenters responding to the January 2022 NOPR, in the July 2022 SNO PR, DOE proposed several updates to its earlier proposals (in section 4.10 of appendix E) for testing circulating water heaters as initially presented in the January 2022 NOPR. 87 FR 42270, 42282–42283 (July 14, 2022). These proposed modifications to DOE’s initial proposal are set forth in the paragraphs that follow.

After re-evaluating the market for heat-pump-only water heaters, DOE tentatively determined that testing such products with a conventional electric storage water (*i.e.*, an electric water heater that uses only electric resistance heating elements) would be more representative than testing with an UFHWST. Therefore, DOE proposed that heat-pump-only water heaters be tested in the medium draw pattern using a 40-gallon traditional electric storage tank (*i.e.*, that provides heat only with electric resistance heating elements) that has a UEF rating at the minimum required at 10 CFR 430.32(d). DOE chose a 40-gallon tank in the medium draw pattern because that size and draw pattern combination has the highest number of models currently available on the market.⁶³ DOE also proposed that, for heat pump-only water heaters, the test be carried out using a tank that does not “over-heat” the stored water (*i.e.*, $T_{\max,1}$ (maximum measured mean tank temperature after cut-out following the first draw of the 24-hour simulated-use test) must be less than or equal to $T_{\text{del},2}$ (average outlet water temperature during the 2nd draw

of the 24-hour simulated-use test); see section III.E.1 of this document for more discussion of water heater “over-heating”). This would ensure that the electric storage tanks are not overheating during the test, thereby ensuring consistency across tests. 87 FR 42270, 42282 (July 14, 2022).

By contrast, DOE maintained its earlier proposal that a UFHWST be used for testing of circulating gas-fired water heaters, as those products are more likely to be installed with a UFHWST in the field. Therefore, DOE tentatively concluded that testing with an UFHWST would be representative for such units. 87 FR 42270, 42282 (July 14, 2022).

In response to the January 2022 NOPR, some commenters suggested that DOE allow manufacturers to specify the storage tank used for testing. DOE noted that this approach could lead to additional test burden for third-party testing laboratories, which may need to acquire more than one storage tank if they are performing tests for multiple manufacturers, each of whom may specify a different storage tank for testing. In order to avoid creating the potential for additional test burden, DOE tentatively determined not to allow manufacturers to specify the electric storage water heater or unfired hot water storage tank used respectively for testing the heat pump-only or gas-fired instantaneous circulating water heaters. Additionally, DOE stated it would consider relevant amendments to certification and reporting requirements in a separate rulemaking. 87 FR 42270, 42282 (July 14, 2022).

After considering the comments regarding the tolerance on the storage tank initially proposed in the January 2022 NOPR, DOE tentatively determined in the July 2022 SNO PR that a wider tolerance would reduce potential testing burden while still providing representative and reproducible results. Specifically, DOE tentatively concluded that a 10-percent tolerance would increase flexibility for manufacturers by increasing the number of tanks that could be used for testing, while not materially impacting the UEF test results. Therefore, consistent with the recommendations provided by commenters, DOE proposed to adopt a 10 percent tolerance (± 10 percent, allowing products with rated storage volumes between 36 gallons and 44 gallons) for the electric storage water heater used for testing heat-pump-only water heaters. 87 FR 42270, 42282 (July 14, 2022).

Additionally, after further review of the market for circulating gas-fired instantaneous water heaters and unfired

⁶³ See Figure 3A.2.8 of the Preliminary Analysis Technical Support Document for consumer water heaters (Docket No. EERE-2017-BT-STD-0019-0018).

hot water storage tanks, DOE proposed in the July 2022 SNOPR to allow testing with a tank at any storage volume between 80- and 120-gallons. Based on further analysis, DOE tentatively determined that variations in the tank size should not significantly impact the result of the test. During a water draw, the internal tank temperature decreases as hot water exits the tank and is replenished by colder water entering the tank. Generally, different tank sizes will result in different rates of internal temperature decrease during a water draw (e.g., during a specified water draw, a smaller tank will generally experience a faster decrease in temperature compared to a larger tank). During a test, any potential differences in the tank water temperature due to the use of different size tanks would be accompanied by a corresponding proportional difference in burner on-time, such that the impact on measured efficiency (i.e., the ratio of energy output to energy input) would be negligible. DOE noted its recognition that a larger tank would likely have more standby losses than a smaller tank; however, DOE tentatively determined that the impact this would have on measure efficiency would also not be significant. 87 FR 42270, 42282–42283 (July 14, 2022).

DOE noted that providing a range of allowable tank volumes would reduce potential burden by providing manufacturers with more tank options, thereby allowing them to pair their circulating gas-fired instantaneous water heaters with an existing UFHWST model. This approach is also likely to be more representative of how the units would be installed in the field as opposed to testing with a custom-made tank for testing or a competitor's tank that meets a specific volume requirement. 87 FR 42270, 42283 (July 14, 2022).

In addition, after considering comments in response to the January 2022 NOPR, DOE tentatively determined in the July 2022 SNOPR that the lack of an upper bound on the thermal insulation value for the UFHWST could lead to differences in measured efficiency that reflect differences in tank performance, rather than reflecting differences in water heater performance. Therefore, DOE tentatively determined that more specific constraints on tank performance are warranted to ensure more comparable test results across the subject water heater models. DOE proposed to require that UFHWSTs used for testing circulating gas-fired instantaneous water heaters exactly meet the baseline energy conservation

standard for UFHWSTs.⁶⁴ 87 FR 42270, 42283 (July 14, 2022). However, DOE did not include commenters' suggested specifications for other tank characteristics (such as the inlet and outlet connection locations, internal tank baffling, and inlet tube designs) for the UFHWST because, as explained in the July 2022 SNOPR, DOE tentatively determined that over-specifying the design of the UFHWST—given the impacts on the UEF rating are minimal—could result in a very narrow range of UFHWST models which could be used for testing circulating water heaters, thereby potentially introducing significant barriers to testing these products at third-party laboratories. In addition, DOE tentatively concluded that it lacked sufficient information regarding these specifications to do so. 87 FR 42270, 42283 (July 14, 2022).

Similarly, DOE proposed that the electric storage water heater used for testing heat-pump-only water heaters have a rated UEF corresponding to the minimum standard found at 10 CFR 430.32(d), thereby helping to ensure more comparable results.

In summary, in the July 2022 SNOPR, DOE proposed to further amend the separate storage tank requirements proposed in the January 2022 NOPR for heat pump-only and gas-fired circulating water heaters. DOE proposed that heat pump-only water heaters be tested with a 40-gallon (± 4 gallons) electric storage water heater that has a UEF value corresponding to the minimum standard for such products and that does not “over-heat”; and that gas-fired circulating water heaters be tested with an 80-gallon to 120-gallon unfired hot water storage tank that is rated equal to the energy conservation standard for such equipment.

In response to the July 2022 SNOPR, NEEA indicated support for DOE's revisions to the proposed test procedure for circulating water heaters. (NEEA, No. 56 at p. 2) A.O. Smith and the CA IOUs supported DOE's proposal requiring gas-fired circulating water heaters to be tested using a UFHWST with a storage volume between 80 and 120 gallons and an R-value exactly at the minimum R-value required at 10 CFR 431.110(a). (A.O. Smith, No. 51 at p. 8; CA IOUs, No. 52 at p. 6) The CA IOUs also indicated support for the revision to require heat pump circulating water heaters to use a 40-gallon electric resistance water heater meeting the minimum UEF requirements. (CA IOUs, No. 52 at p. 6)

⁶⁴ Currently, baseline energy conservation standards for UFHWSTs require a thermal insulation of R-12.5. 10 CFR 431.110(a).

AHRI stated that allowing manufacturers to specify the storage tank used for testing circulating water heaters would not increase test burden for third-party laboratories because manufacturers would provide both the water heater and the storage tank it was designed to be used with to the laboratories. (AHRI, No. 55 at pp. 5–6) BWC suggested that the capacity range of 80 to 120 gallons for UFHWSTs used to test circulating water heaters is too wide to ensure consistent results, so, therefore, the commenter requested that DOE complete further testing to validate it. (BWC, No. 48 at p. 4)

After considering these comments, DOE has concluded that providing a range of allowable tank volumes for use with circulating gas-fired instantaneous water heaters as described in the July 2022 SNOPR would reduce potential burden by providing manufacturers with more tank options, thereby allowing them to pair their circulating gas-fired instantaneous water heaters with an existing UFHWST model. This approach balances manufacturer burden (by allowing flexibility in the tank size) with ensuring reproducibility of test results (by limiting the options to a fixed range of sizes). In response to AHRI's comments, DOE notes that it is not adopting changes to the certification requirements in this final rule, and whether or not manufacturers may specify a specific model of UFHWST is an issue out of the scope of this test procedure rulemaking and will be addressed in a future rulemaking addressing certification requirements for consumer water heaters.

As such, in this final rule, DOE is adopting the separate storage tank requirements for circulating gas-fired instantaneous water heaters as proposed in the July 2022 SNOPR. In response to BWC's comment, DOE understands that the choice of tank size may result in slightly different ratings for these products, and BWC seeks to determine how much variability in results there would be if testing were to be conducted with an 80-gallon UFHWST versus a 120-gallon UFHWST. However, the Department's approach is instead to permit manufacturers some flexibility in testing options so as to be able to tailor the tank pairing to the design or application intent of the circulating water heater, and to then subsequently account for the variation in ratings when setting amended standards for circulating water heaters by having the required UEF be a function of the effective volume. As discussed in section III.I of this document, compliance with the separate storage tank test method will not be required

until compliance with amended energy conservation standards is mandatory, if such standards are adopted.

Additionally, section III.F.2.b of this document describes the use of the effective storage volume metric to be able to associate efficiency ratings to the storage tank size for circulating water heaters. This matter is discussed further in this section in response to other comments. In taking these steps, DOE can, in the ongoing standards rulemaking for consumer water heaters, propose and request comment on new energy conservation standards for circulating water heaters that are functions of the effective storage volume.

SMTI requested that DOE widen the accepted volume range for electric storage tanks used to test separate heat pump-only water heaters based on the performance requirements of each product instead of requiring that all products be tested with a 40-gallon tank. (SMTI, No. 49 at p. 1) SMTI suggested that heat pump-only water heaters be tested with manufacturer-specified storage tanks, which the manufacturer would provide to third-party laboratories, and that a 40-gallon tank be used if a specific storage tank is not specified. (SMTI, No. 49 at p. 2) A.O. Smith stated that there is insufficient data to conclude that the 40-gallon electric resistance water heater should be used for testing heat-pump-only or split-system water heaters and that a 50-gallon electric resistance water heater may be more representative based on manufacturer data. (A.O. Smith, No. 51 at p. 9) However, A.O. Smith did not provide any manufacturer data to support its claim that a 50-gallon electric resistance water heater would be more representative.

As described in the July 2022 SNOPR, DOE selected a 40-gallon tank in the medium draw pattern because that size and draw pattern combination has the highest number of models currently available on the market as observed in models currently certified to DOE's Compliance Certification Database (see Figure 3A.2.8 of Preliminary Analysis TSD). 87 FR 42270, 42282 (July 14, 2022). This finding has not changed since the publication of the July 2022 SNOPR, and on this basis (because additional data were not provided by stakeholders), DOE has concluded that this tank size and draw pattern are the most representative choice to be paired with a heat pump-only water heater. In response to SMTI's request to widen the volume range, DOE has determined to adopt a volume tolerance of ± 5 gallons, as opposed to $\pm 10\%$ (4 gallons) which was proposed in the July 2022 SNOPR.

This change is based on further inspection of the rated storage volumes of electric storage water heaters which have a nominal capacity of "40 gallons" as observed in models certified to DOE's Compliance Certification Database. As such, DOE does not expect the difference to be substantial in impacting energy efficiency results for circulating heat pump water heaters because the volume range covers products of the same nominal volume. As previously stated in response to a comment made by AHRI, DOE is allowing manufacturers to specify an effective storage volume for the tank rather than a specific model because any characteristics of the tank that would affect the efficiency rating of the circulating water heater during a test are accounted for in the volume and efficiency rating (in this case, UEF) of the tank.

AHRI and BWC indicated that DOE's primary TSD for energy conservation standards for consumer water heaters suggests that the 40-gallon electric resistance water heaters used to test heat-pump-only water heaters may be phased out by future DOE regulations. (AHRI, No. 55 at p. 5; BWC, No. 48 at pp. 4–5) Rheem supported AHRI's comment on this issue. (Rheem, No. 47 at p. 5)

In response, DOE notes that the current energy conservation standards rulemaking for consumer water heaters is still ongoing, and any preliminary results published as part of that rulemaking are neither final nor binding in any way. Consequently, it is not confirmed that electric resistance storage water heaters will be phased out. Nevertheless, to ensure there will be no confusion in the event such regulatory changes were to occur, DOE is removing the requirement that the storage tank use only electric resistance heating elements. Accordingly, the associated portion of section 4.10 of appendix E has been updated to read as follows:

"When testing a heat pump circulating water heater, the tank to be used for testing shall be an electric storage water heater that has a measured volume of 40 gallons (± 5 gallons), has a First-Hour Rating greater than or equal to 51 gallons and less than 75 gallons resulting in classification under the medium draw pattern, and has a rated UEF equal to the minimum UEF standard specified at 10 CFR 430.32(d), rounded to the nearest 0.01. The operational mode of the heat pump circulating water heater and storage water heater paired system shall be set in accordance with section 5.1.1 of this appendix."

In its comments on the July 2022 SNOPR, A.O. Smith supported ensuring that non-unitary heat pump water heaters⁶⁵ intended for use in a single-family home or an individual dwelling unit that need to be paired with a separate storage tank are tested and certified to the Department consistent with appendix E. (A.O. Smith, No. 51 at pp. 8–9) A.O. Smith also requested that DOE clearly define the test apparatus for heat pump circulating water heaters. (A.O. Smith, No. 51 at p. 9)

In response to concern from certain stakeholders, DOE will allow manufacturers of gas-fired circulating water heaters to represent thermal efficiency test results measured according to the commercial water heaters test procedure outlined at 10 CFR part 431, subpart G, in addition to the required UEF test results. DOE also notes that this final rule clearly defines the test apparatus for circulating heat pump water heaters in section 4.10 of the amended appendix E.

Rheem reiterated its request for clarification as to whether a system (*i.e.*, a heat pump and storage tank designed to be used together) can be certified independent of the proposed method to use a specific storage tank or electric resistance water heater. (Rheem, No. 47 at p. 5) Rheem also requested that DOE address whether a split-system water heater, designed to be used with an 80-gallon tank, can have a storage tank with electric resistance elements and whether a replacement tank can be sold. (Rheem, No. 47 at p. 5)

In response to Rheem, DOE would clarify that a product which consists of a heat pump and a storage tank designed to be used together and are sold together would constitute a "split-system heat pump water heater." Such a system would be certified altogether as an electric storage water heater, and there would be no need to use the test procedure provisions for a separate storage tank. If the heat pump module were sold separately and independent of the tank, then it would constitute a "circulating heat pump water heater," and the test procedure provisions for a 40-gallon ± 5 gallon separate storage water heater would then apply. In Rheem's example of a product with an 80-gallon storage tank, that configuration would constitute a "split-

⁶⁵ DOE understands "non-unitary heat pump water heaters" to refer to products which consist of a heat pump system to heat water but are not packaged with the rest of the components used in domestic hot water production (*i.e.*, a hot water storage tank). These products are considered circulating heat pump water heaters in this rulemaking.

system heat pump water heater”—an electric storage water heater with a storage volume of 80 gallons. The separate storage tank provisions do not apply to such a product. The 80-gallon storage tank component of the split-system heat pump water heater may have electric resistance back-up elements. Replacement storage tanks sold on a separate basis—essentially an electric resistance water heater with a storage volume of 80-gallons—would not be permitted, because electric resistance heating elements would not be able to achieve the UEF energy conservation standard levels mandatory for electric storage water heaters greater than 55 gallons for which compliance is currently required (*see* 10 CFR 430.32(d)).

In response to the January 2022 NOPR, A.O. Smith also commented that the energy from a circulating pump should be used in the UEF calculations and that the flow rates between the circulating heat pump water heater and the storage tank should be specified by the manufacturer. (A.O. Smith, No. 37 at p. 3) DOE agrees that including the energy use of the circulating pump is appropriate and consistent with the currently applicable appendix E test procedure, which requires measurement of power consumption of auxiliary electricity-using components. In this final rule, for water heaters which require separate storage tanks, the power consumption of the circulating pump shall be directly metered if the pump is integrated into the water heater. Section 4.10 of the amended appendix E test procedure will require that if the water heater is supplied with a separate, non-integrated circulating pump, it is to be installed as per the manufacturer's installation instructions, and its power consumption will similarly be accounted for in the energy measurements to determine UEF.

In conclusion, after considering comments received in response to the January 2022 NOPR and the July 2022 SNOPR, DOE is adopting the requirements for separate storage tanks as discussed in this final rule.

DOE's previous proposals involving the use of separate storage tanks did not specify a test procedure by which the storage volume of unfired hot water storage tanks paired with circulating water heaters to determine efficiency is to be measured. It is important to obtain a precise measurement of the storage volume of the UFHWST because its physical size affects the measured efficiency of the water heater due to standby losses of heat from the stored water to the air surrounding the storage

tank; these standby losses increase as the size of the tank increases.

To ensure the accuracy and repeatability of test results, DOE is amending sections 4.10 and 5.2.1 of appendix E so that the method for determining storage tank volume specified in section 5.2.1 must also be conducted to verify the volume of unfired hot water storage tanks used to test circulating water heaters. In this method, storage volume is determined in gallons by subtracting the tare weight, measured while the tank is dry and empty, from the weight of the system when filled with water and dividing the resulting net weight of water by the density of water at the measured water temperature. This method is consistent with how the volume of unfired hot water storage tanks is currently rated. It is also the method specified for storage-type and storage-type instantaneous commercial water heaters under subpart G to 10 CFR part 431.

Additionally, as discussed in section III.F.2.b of this document, DOE is establishing that the effective storage volume of a circulating water heater is equivalent to the measured storage volume of the separate storage tank which was used during testing of the circulating water heater. This alleviates the manufacturers' concerns by ensuring that the standby losses reflected in the UEF rating of the circulating water heater can be mapped to the volume of the separate storage tank which was used during testing without having to specify a particular model of tank, for example. DOE would consider this tank volume in the development of energy conservation standards for circulating water heaters.

E. Test Conduct

As discussed throughout this rulemaking, EPCA requires that any test procedures prescribed or amended under this section shall be reasonably designed to produce test results which measure energy efficiency, energy use, or estimated annual operating cost of a covered product during a representative average use cycle (as determined by the Secretary) or period of use and shall not be unduly burdensome to conduct. (42 U.S.C. 6293(b)(3)) The proposed changes to test conduct, along with specific stakeholder comments received and DOE's responses, are discussed further in the subsections that immediately follow.

1. High Temperature Testing

Certain electric storage water heaters on the market are capable of raising the temperature of the stored water significantly above the outlet water

temperature requirements specified in section 2.4 of appendix E, while still delivering water at a lower temperature that is at or near the temperature specified in appendix E. The storage tank is heated to a temperature which is still within the normal operating range of the water heater, but a mixing valve is typically installed with these products (either integrated into the water heater by the manufacturer at the factory, or added to the water heater in the field by the installer) to temper the outlet water to a more typical delivery temperature. (Set-up requirements for mixing valves that are to be used during testing are discussed in section III.D.2 of this final rule.) When the outlet water is tempered like this, a smaller amount of the hot water from the tank is required to meet demand (because the water in the tank is hotter than desired). Because less water needs to be removed from the tank, the effect of a mixing valve is to increase the amount of hot water that can be delivered overall by the water heater. In addition to determining the set-up considerations to test these products in a representative manner, DOE must consider the impact of raising the storage tank temperature significantly above the setpoint outlet temperature (*i.e.*, “storage tank overheating”) on the efficiency of a water heater since this represents how the water heater will be used in the field.

As discussed in the July 2022 SNOPR, storage tank overheating increases the amount of hot water that a given size water heater can deliver. 87 FR 42270, 42277–42278 (July 14, 2022).

Historically, it has not been uncommon for water heaters to come with the capability to adjust the settings to increase the temperature of the water being stored in the tank, although, it is DOE's understanding that in the past, consumers rarely modified the preconfigured settings on their storage tanks. However, DOE has recently become aware of products that are being marketed to consumers with “capacity boosting” capabilities so as to avoid the need to install a larger storage-type water heater. The products (that DOE addressed in the July 2022 SNOPR) are equipped with user-operable modes which set the water heater to boost the storage tank temperature and use a built-in mixing valve (or one installed at the point of manufacture) to automatically maintain the delivery temperature. For example, one manufacturer produces 30-, 40-, and 50-gallon water heaters with an “X-High Setting” claiming to provide the same amount of hot water (“Effective Capacity,” as the manufacturer refers to

it) as significantly larger water heaters with a more typical storage tank temperature of 125 °F—such as an 80-gallon capacity for the 50-gallon model, 64-gallon capacity for the 40-gallon model, and 48-gallon capacity for the 30-gallon model.⁶⁶ DOE notes that the 40-gallon model and the 50-gallon model are capable of providing effective capacities greater than 55 gallons, which, based on effective capacity, would put these models into a different product class. (see 10 CFR 430.32(d)). Another manufacturer produces a 55-gallon water heater with a variety of settings allowing the user to get “performance equivalency” of a 65-, 80-, or 100-gallon tank, stating that the tank raises the temperature safely up to 170 °F.⁶⁷ Again, these increased capacities would put this model into a different product class.

As stated in the July 2022 SNO PR, consumers would be expected to use the over-heated mode as part of the regular operation of their water heater. Accordingly, for such products, DOE expects that a representative average use cycle would include some portion of time in over-heated mode. 87 FR 42270, 42279 (July 14, 2022). For these water heaters, DOE believes that a representative average use cycle in the test procedure must encompass the “capacity boosting” capability, as this is the mode that DOE believes the consumer will likely be using once installed in the field, because such purchases are likely predicated on this capacity-boosting capability.

The operational mode selection instructions in section 5.1 of appendix E do not specifically address the situation when a water heater has this type of operational mode that boosts the capacity. In response to the January 2022 NOPR, several commenters requested that DOE consider amendments to the appendix E test procedure to provide more representative efficiency results (including ways to account for the increased effective capacity) for these products that “overheat” the stored water beyond the delivery temperature. After considering these comments in the July 2022 SNO PR, DOE proposed to establish additional requirements for the testing of water heaters which have these operational modes. 87 FR 42270, 42278 (July 14, 2022).

In order to further examine the potential impacts of storing water at temperatures higher than the delivery temperature, DOE performed testing on one 50-gallon electric resistance storage water heater that includes a built-in mixing valve and multiple user-selectable modes to boost the delivery capacity through storage tank overheating. As described in the July 2022 SNO PR, DOE collected data at three different storage tank temperatures, each of which provided an outlet water temperature at 125 °F ±5 °F through the use of the built-in mixing valve. DOE compared the maximum measured mean tank temperature after cut-out following the first draw of the 24-hour simulated-use test ($\bar{T}_{\max,1}$) to the average outlet water temperature during the second draw ($\bar{T}_{\text{del},2}$) as an indicator of the degree of “overheating.” DOE’s test data is provided in Table III.3 of the July 2022 SNO PR. 87 FR 42270, 42278–42279 (July 14, 2022).

The test results indicated that storage tank overheating clearly leads to an increase in the measured FHR value. The test configuration corresponding to the current DOE test procedure produced an FHR value of 77 gallons. The overheated configurations with mean tank temperatures of 144.5 and 159.6 produced FHR values of 81 and 95 gallons, respectively. DOE notes that an FHR of 95 gallons is comparable to that of a 100-gallon electric storage water heater.⁶⁸ However, increasing the temperature of the stored water can reduce energy efficiency because the hotter tank undergoes substantially higher standby energy losses. As shown in Table III.3 of the July 2022 SNO PR, DOE’s test data show that at a tank temperature of 124.3 °F, the measured UEF is 0.94, which is compliant with the current standards. When the temperature is increased to 144.5 °F, the UEF decreases to 0.90. Further increasing the temperature to 159.6 °F decreases the UEF to 0.88. 87 FR 42270, 42279 (July 14, 2022).

All of the tested temperatures correspond to normal operational modes for the water heater, and a review of publicly-available product literature indicates that products that utilize storage tank overheating generally offer user-selectable operational modes that result in stored water temperatures ranging from 100 °F to 170 °F.

Consumers who choose to use a high-capacity (*i.e.*, “overheated”) mode will experience the water heater performing

significantly worse in terms of its energy efficiency rating than if the rating were determined based on testing without storage tank overheating. In other words, the rated efficiency at the rated delivery capacity would not be representative of an average use cycle or period of use when operated in a high-capacity mode. 87 FR 42270, 42279 (July 14, 2022).

In the July 2022 SNO PR, DOE surmised that consumers who purchase a water heater that provides overheating capability would do so with the intent to use such capability; as such, these consumers would be expected to use the over-heated mode some portion of the time, ranging from occasional use (*e.g.*, switching between the normal mode and the overheated mode depending on the hot water capacity needed at any particular time) to regular use. Accordingly, for such products, DOE expects that a representative average use cycle would include some portion of time in overheated mode. For this reason, DOE tentatively determined that testing storage-type water heaters that offer user-selectable overheated modes in the overheated mode would provide a more representative result than testing in the default mode. Therefore, DOE proposed to amend section 5.1 of appendix E to require that for water heaters that offer a user-selected operational mode(s) in which the storage tank is maintained at a temperature higher than the delivery temperature, the operational mode shall be that which results in the highest mean tank temperature while maintaining an outlet temperature of 125 °F ±5 °F. Because this amendment would change the measured energy efficiency, DOE proposed that compliance with this requirement would not be necessary until the compliance date for amended energy conservation standards. 87 FR 42270, 42279 (July 14, 2022).

As explained in the July 2022 SNO PR, demand-response water heaters with the capability to undergo utility-initiated overheating would not be expected to increase the capacity of the water heater over a typical average use cycle in the same way that a water heater with user-initiated overheating would, so DOE had tentatively concluded that testing demand-response water heaters in the default/normal would be the most representative method for those products. Therefore, DOE proposed to define “demand-response water heater” (see section III.A.1 of this document) and exclude such products from the requirement to test in the operational mode that results in the highest mean tank temperature while maintaining an

⁶⁶ See, for example: www.geappliances.com/appliance/GE-Smart-50-Gallon-Electric-Water-Heater-with-Flexible-Capacity-GE50S10BMM (Last accessed April 14, 2023).

⁶⁷ For example, DOE’s Compliance Certification Database includes a 107-gallon electric storage water heater with an FHR of 94 gallons.

⁶⁸ For example, DOE’s Compliance Certification Database includes a 107-gallon electric storage water heater with an FHR of 94 gallons.

outlet temperature of 125 °F ±5 °F, even if they are capable of overheating the stored water. 87 FR 42270, 42280 (July 14, 2022).

In response to the July 2022 SNO PR, BWC stated that the phrase “storage tank overheating” may be confusing to consumers and suggested that DOE find an alternate phrase to describe this concept (*i.e.*, “water heaters with high heat modes”). (BWC, No. 48 at p. 3) GEA also disagreed with DOE’s use of the term “over-heating” to refer to water heaters that can deliver water at lower temperature than that at which it is stored, suggesting “delivery-control” as an alternative, given that these products heat in the manner intended. (GEA, No. 53 at p. 2) In response to these comments and acknowledging the sensitivity around the potentially negative connotation of the term “overheating,” as noted earlier in this document, DOE’s use of the term “overheating” does not denote performance outside of the normal operating range of the water heater, but rather refers to raising the tank temperature above the outlet water setpoint. To avoid any potential confusion, DOE will hereinafter refer to water heaters with overheating capability as water heaters with “high heat modes.”

The following subsections summarize the remaining comments received in response to the provisions proposed in the July 2022 SNO PR for water heaters with high heat modes and include DOE’s additional assessments of the impact on UEF ratings, representativeness of the test method, and implications for compliance with standards associated with high temperature testing.⁶⁹ As discussed in the following subsections, DOE has concluded that including test conduct provisions for determining the ratings of water heaters tested using the high temperature testing method would be justified. Therefore, in this final rule, DOE is establishing the methodology for determining ratings for electric resistance storage water heater using high temperature testing in appendix E, but DOE is allowing voluntary representations at this point. Specifically, manufacturers may opt to use the high temperature test method in addition to the regular temperature

⁶⁹ DOE is establishing a method for testing water heaters at an elevated tank temperature, including water heaters without “high heat modes.” Therefore, DOE refers to water heaters with a built-in mixing valve and operational mode for overheating the water in the tank as water heaters with “high heat modes” but refers to the testing of water heaters at elevated storage water temperatures as “high temperature testing.”

setting test method if they desire to make voluntary representations of the efficiency when tested in high temperature mode. DOE will consider establishing requirements for which electric resistance storage water heaters must be tested and represented according to the method for high temperature testing in its ongoing energy conservation standards rulemaking for consumer water heaters. Until such time, the regular test method is mandatory for compliance with the current Federal energy conservation standards.

a. Impact on UEF Ratings

In response to the July 2022 SNO PR, ASAP, ACEEE, and NRDC expressed support for DOE’s proposal for addressing storage-type water heaters that heat the stored water beyond the delivery temperature. (ASAP, ACEEE, and NRDC, No. 54 at p. 2)

NEEA supported DOE’s proposal to test water heaters in a user-selectable “overheat” mode when such a mode is available, as well as DOE’s proposed methodology for identifying “overheat” modes. NEEA also indicated that it had performed testing on two 120-volt heat pump water heater models which had these modes available, and its test results showed a significant reduction in efficiency when the water heater was set to store water at an elevated temperature of 140 °F.⁷⁰ Thus, NEEA stated that requiring testing in the “overheat” mode would help realize the energy and cost savings intended with efficiency standards. (NEEA, No. 56 at p. 2)

BWC disagreed that water heaters with high heat modes should have separate testing requirements and expressed concern that tests to examine the potential effects of heating stored water above the delivery temperature setpoint were conducted on a single 50-gallon electric resistance storage water heater. BWC urged DOE to conduct further testing before finalizing this proposal. (BWC, No. 48 at p. 3) In response, DOE notes that the UEF ratings of products which store water at higher temperatures will be lower due to the higher standby losses incurred as a result of this high temperature storage. DOE did, however, conduct additional testing (see section III.F.2 of this document) to determine that the method of determining effective storage volume from the high temperature testing will only affect products which significantly

⁷⁰ An August 30, 2022 report by NEEA containing test data for these water heaters can be found online at: [needa.org/resources/plug-in-heat-pump-water-heaters-an-early-look-to-120-volt-products](https://www.needa.org/resources/plug-in-heat-pump-water-heaters-an-early-look-to-120-volt-products) (Last accessed on Nov. 22, 2022).

increase capacity by increasing storage temperature.

Additionally, DOE reviewed the heat pump water heater test data referenced in NEEA’s comment. NEEA tested two 50-gallon 120-volt heat pump water heaters at two storage setpoint temperatures (*i.e.*, 125 °F and 140 °F), with mixing valves installed to temper the delivery to 120 °F. NEEA’s report concludes that the recovery efficiency can decrease by a factor of 3 to 8 percent when the setpoint temperature is increased from 125 °F to 140 °F. The higher setpoint temperature resulted in an increase in FHR of approximately 13 gallons. NEEA’s report also states that at 67.5 °F ambient air, an increase in the setpoint temperature could increase standby losses by 25 percent, although NEEA stated that standby losses contribute less to the overall energy consumption of a heat pump water heater compared to recovery periods. DOE notes that NEEA did not conduct standby loss testing or present the UEF results of these water heaters in each mode. DOE expects that the standby loss from having a higher setpoint temperature would have a more significant impact on electric resistance water heaters because the recovery efficiency of electric resistance heating is not affected by the water temperature.⁷¹ However, in conjunction with DOE’s own test data (which was obtained through full 24-hour simulated use test measurements of an electric resistance storage water heater), DOE has determined that high temperature testing would result in significantly lower UEF results compared to setting the tank temperature close to the delivery setpoint of 125 °F.

Given the significant difference in UEF performance that have been observed based on the temperature of the water stored in the tank, DOE has concluded it is appropriate to provide a method to conduct high temperature testing. Section III.E.1.d of this document describes how DOE is establishing the requirements for high temperature testing. Due to the expected impacts of high temperature testing on UEF, DOE will not require compliance with this test method until compliance with amended energy conservation standards accounting for such water heaters is also required.

⁷¹ Section 6.3.2 of the currently applicable appendix E test procedure (which will be re-located to section 6.3.3 upon the effective date of this final rule) states that the recovery efficiency for electric water heaters with immersed heating elements, not including heat pump water heaters with immersed heating elements, is assumed to be 98 percent.

b. Demand-Response Water Heaters

As discussed previously, in the July 2022 SNO PR, DOE proposed to define “demand-response water heater” and exclude such products from the proposed requirement to test in the operational mode that results in the highest mean tank temperature while maintaining an outlet temperature of 125 °F ±5 °F, even if they are capable of heating the stored water above the delivery temperature. 87 FR 42270, 42280 (July 14, 2022).

In response to the July 2022 SNO PR, NYSERDA indicated that water heaters with demand-response functionality should be excluded from testing at the highest tank temperature available. (NYSERDA, No. 50 at p. 3) A.O. Smith agreed with DOE’s assessment that demand-response water heaters need the operational capability to “over-heat” the stored water in the tank above the intended outlet water temperature in response to a signal or command from a utility or third-party aggregator. The commenter stated that these load-up events are typically short in duration and do not keep the stored water in an over-heated state continuously or permanently. However, A.O. Smith raised concerns about the impact of this proposed amendment on the availability of the high heat mode feature on non-demand-response products. A.O. Smith urged DOE to continue to allow non-demand-response heat pump water heaters with selectable high heat modes to retain this functionality for customer utility. (A.O. Smith, No. 51 at pp. 5–6)

In contrast, the CA IOUs suggested that demand-response capable water heaters should be subject to the same test procedure as other water heaters capable of operating in high heat modes. (CA IOUs, No. 52 at p. 6)

As noted in section III.A.1 of this document, DOE is not establishing a definition for “demand-response water heater” in this final rule in order to prevent potential industry confusion from arising due to any differences in the features requirements specified in such definition. However, DOE has found it appropriate to still consider factors which would help to determine whether it is most representative to require demand-response water heaters to test at the highest tank temperature setting.

As described in the July 2022 SNO PR and discussed in section III.A.1 of this document, high-temperature water storage occurring in demand-response water heaters and initiated by the electric utility serves an important purpose for energy storage and grid flexibility. 87 FR 44270, 42279–42280

(July 14, 2022). Additionally, DOE noted that demand-response water heaters do not perform this action to increase the overall daily capacity of the water heater. Instead, the capacity is only temporarily boosted to counteract the deactivation of the heating elements for extended periods of time when demand curtailment is occurring. As such, demand-response water heaters with the capability to undergo only utility-initiated high heat modes would not be expected to increase the capacity of the water heater over a typical average use cycle in the same way that a water heater with the ability to have the user increase the storage tank temperature would. *Id.*

To reiterate, EPCA requires that any test procedures prescribed or amended shall be reasonably designed to product test results which measure energy efficiency, energy use, or estimated annual operating cost of a covered product or equipment during a representative average use cycle or period of use and not be unduly burdensome to conduct. (42 U.S.C. 6293(b)(3); 42 U.S.C. 6314(a)(2)). Thus, DOE must determine whether testing at the highest tank temperature setting during the delivery capacity test and the 24-hour simulated-use test is representative of an average use cycle for a demand-response water heater. Based on information collected during this rulemaking, including the comment from NYSERDA, demand-response water heaters do not typically remain in a high-temperature storage state for the entirety of a 24-hour average use cycle. The additional energy used and stored when this type of water heater increases the tank temperature is offset by significant periods of low energy usage such that, over a 24-hour average use cycle, the total energy stored and consumed by the water heater is similar to that for a product which maintains a normal storage tank temperature throughout the day.

In response to A.O. Smith’s concern about non-demand-response water heaters, as discussed in further detail in sections III.E.1.c and III.E.1.d of this document, DOE notes that the provisions finalized in this rulemaking do not require high temperature testing for any water heaters in particular at this time and, therefore, would not preclude the possibility of non-demand-response heat pump water heaters having user-selectable high heat modes. DOE will consider these concerns further at such time as it proposes to require high temperature testing for certain types of water heaters in a future rulemaking.

c. Representativeness of Field Use

AHRI indicated that additional operational modes to heat water above 125 °F are not meant to be the primary mode of operation and should not be used continuously. AHRI stated that the proposal in the July 2022 SNO PR to test water heaters with these modes at the settings providing the highest internal tank temperature does not reflect the purpose of these modes, and that proposal would require more test data than provided in the NOPR to understand its consequences. For these reasons, AHRI requested that DOE retract this proposal from the current rulemaking and address it at a later time. (AHRI, No. 55 at p. 6) Similarly, Rheem requested that DOE not consider water heaters with a temporary, non-default high heat mode as being water heaters with high heat modes and that DOE not include any changes related to high heat modes in the final rule. (Rheem, No. 47 at p. 6)

GEA argued that the essential function of “delivery-control” water heaters is no different than a consumer who sets their standard storage water heater to a higher temperature and regulates water temperature at the tap by mixing in cold water. GEA added that “delivery-control” water heaters provide practical energy savings benefits not captured by the consumer water heater test procedure, and that these energy savings benefits mitigate against requiring testing at the maximum tank storage temperature. Specifically, GEA described a use case where a consumer may use a “delivery-control” water heater in a high heat mode on occasion when more guests are in the home, which they suggested would, on balance, use less energy as compared to full time use of a water heater with an oversized storage capacity. (GEA, No. 53 at p. 3)

GEA suggested that many consumers already set their storage water heater to temperatures above 140 °F and that “delivery-control” water heaters simply allow consumers to do so in a safer way by premixing to a lower temperature, adding that such water heaters should not be penalized through efficiency ratings for providing a safety feature to prevent scalding. (GEA, No. 53 at p. 3)

GEA stated that DOE has provided no evidence that setting “delivery-control” water heaters at their maximum storage temperature is a “representative average use cycle or period of use” as required by EPCA at 42 U.S.C. 6293(b)(3). GEA also noted that many other products regulated under EPCA have modes that allow for increased or decreased energy consumption relative to their default

setting but that these modes are not included in their respective DOE test procedures because they have not been deemed representative of an average use cycle. (GEA, No. 53 at p. 4)

NYSERDA recommended that all water heaters with the option to elevate the tank temperature, except those with demand-response functionality, should be tested at the highest tank temperature available, as thermostatic mixing valves are regularly installed in the field. (NYSERDA, No. 50 at p. 3) The CA IOUs also commented that external mixing valves are readily available to consumers, and in at least one State (Vermont), they are required for all residential water heater installations. Therefore, the CA IOUs urged DOE to consider changes to its regulations that would further incentivize installers and consumers to minimize installation costs at the expense of energy efficiency. (CA IOUs, No. 52 at p. 5) GEA stated that thermostatic mixing valves can be integrated into a product at the factory or added as an accessory at a consumer's home and suggested that if manufacturers are required to make "inaccurate" representations of energy consumption for mixing valves integrated at factories, more mixing valves will be sold as accessories, because consumer demand for flexibility and safety will not change. (GEA, No. 53 at p. 4)

As previously discussed in the July 2022 SNOPR and in response to the comments of AHRI and Rheem, DOE expects that consumers who purchase a water heater with high heat modes intend to use it in order to meet hot water demands; therefore, testing these water heaters using only the default operational mode would not be representative of the product's energy consumption over an average use cycle. 87 FR 42270, 42279 (July 14, 2022). From its review of product literature, DOE has found that manufacturers of water heaters with high heat modes market these products as smaller storage water heaters which provide the delivery capacities of larger storage water heaters, and consumers may opt to install a smaller water heater with high heat mode in lieu of a larger water heater as a result (e.g., if a larger water heater does not fit in the installation space). As such, in order to yield efficiency results that would be most representative of the product's enhanced delivery capabilities, DOE has concluded that it would be necessary to include a high temperature testing method.

In light of these comments, DOE has determined that the ability to operate with an elevated tank temperature is not

limited to products with built-in mixing valves and user-selectable capacity boosting settings. DOE agrees with commenters that a product with a field-installed mixing valve and the storage tank manually set to a higher temperature could operate in much the same way, and that this practice may be prevalent given how readily available separate mixing valves are to consumers. As a result of these considerations, DOE concludes that it is possible such testing could be appropriate for models capable of heating and storing water above the delivery temperature specified in the test method while still delivering water at the setpoint temperature of 125 ± 5 °F. Thus, DOE is not limiting the high temperature testing method only to products with a specific capacity boosting mode. In other words, manufacturers may optionally apply the high temperature test method to electric resistance storage water heaters with the capability to heat and store water above the delivery setpoint temperature of 125 ± 5 °F, including products that would require a field-installed mixing valve to do so.

The provisions for high temperature testing adopted by this final rule complement the existing operational mode selection requirements, which, generally, would require water heaters to be set to a "normal" storage tank temperature close to the delivery setpoint of 125 °F (see section 5.2.1 of the currently applicable appendix E test procedure). Specifically, the high temperature testing provisions require setting the water heater to the highest storage tank temperature and installing a separate mixing valve to temper the delivery water to the outlet water requirements for products that do not already have a mixing valve installed. If the product is equipped with a built-in mixing valve, then the water heater's storage tank temperature shall be set to the highest temperature which allows the built-in mixing valve to deliver water in accordance with the outlet water requirements.

d. Use of High Temperature Testing

In response to the July 2022 SNOPR, NEEA agreed with DOE's proposal to implement this testing requirement only upon adoption of new standards. (NEEA, No. 56 at p. 2) A.O. Smith supported the Department's position that the effective date of the proposed changes to the test procedure covering user-selectable over-heat modes for non-demand-response water heaters should coincide with the compliance date of any amendments to the energy conservation standards for consumer

water heaters. (A.O. Smith, No. 51 at p. 6)

Rheem stated that DOE's proposal to delay testing until amended standards are required may not align with EPCA at 42 U.S.C 6293(c)(2)⁷² and requested clarification on DOE's interpretation of this statutory provision. (Rheem, No. 47 at p. 5) Rheem also requested DOE's interpretation of the 42 U.S.C. 6293(e)(2) requirement to "amend the applicable energy conservation standard during the rulemaking carried out with respect to such test procedure" with respect to water heaters with high heat modes because the amended test procedure will alter their measured efficiency. (Rheem, No. 47 at p. 5)

In response to Rheem's questions regarding the relevant statutory provisions at 42 U.S.C. 6293(c)(2) and (e)(2), DOE has concluded that the Department's approach comports with both of these EPCA provisions. To recap, as discussed in section III.I of this document, DOE is not requiring compliance with the high temperature testing provisions until compliance with amended energy conservation standards that address water heaters with such capabilities, if finalized, because DOE has determined that this change to the test procedure will impact the measured efficiency of such water heaters. Under 42 U.S.C. 6293(c)(2), effective 180 days after an amended or new test procedure is prescribed or established for a covered product, no regulated party (i.e., manufacturer, distributor, retailer, or private labeler) may make any representations about the energy use or efficiency of such product unless it has been tested according to the new or amended test procedure and such representations fairly disclose the results of such testing. In the present case, DOE is making clear that its test procedure provisions related to high temperature testing are not required to be used until the compliance date of any amended standards that address such water heaters.

Under 42 U.S.C. 6293(e)(1), DOE must determine whether any test procedure amendments would alter the measured energy efficiency, energy use, or

⁷² Under 42 U.S.C. 6293(c)(2), the statute provides that effective 180 days after an amended or new test procedure applicable to a covered product is prescribed or established under paragraph (b) of this section, no manufacturer, distributor, retailer, or private labeler may make any representation— (A) in writing (including a representation on a label); or (B) in any broadcast advertisement, with respect to energy use or efficiency or, in the case of showerheads, faucets, water closets, and urinals, water use of such product or cost of energy consumed by such product, unless such product has been tested in accordance with such amended or new test procedure and such representation fairly discloses the results of such testing.

measured water use of any covered products as determined under the existing test procedure. As explained elsewhere, DOE has determined that the provisions for high temperature testing would alter measured efficiency, so this statutory provision is likewise satisfied.

Finally, under 42 U.S.C. 6293(e)(2), if DOE determines that its amended test procedure will alter the measured energy efficiency or energy use of a covered product, the Department shall amend the applicable energy conservation standard during the rulemaking carried out with respect to such test procedure. This provision applies to the currently applicable energy conservation standard. As noted previously, the high temperature testing provisions that would alter the measured energy efficiency of certain water heaters are not required for determining compliance with the currently applicable standard. These provisions would only be required on the compliance date of any amended standards that address such water heaters. As such, there is no need to amend the current standards under 42 U.S.C. 6293(e)(2).

DOE has determined that the high temperature test method should apply to electric resistance storage water heaters for the reasons discussed in section III.E.1 of this document. Specifically, based on information from stakeholders regarding the operation of demand-response water heaters (see section III.E.1.b of this document) and the Department's own testing and calculations (see section III.F.2.a of this document), DOE has determined that the high temperature test method would apply to electric resistance storage water heaters that are capable of raising their internal tank temperature significantly above their delivery temperature, without utility initiation, to boost hot water delivery capacity in order to meet daily household needs. Products which raise the internal tank temperature only as part of demand-response operation should not use this method.

In this rulemaking, commenters have urged DOE to provide better clarity and specificity regarding which water heaters may be "exempt" from high temperature testing (for example, see NYSEDA's comments discussed in section III.A.1 of this document). In the concurrent energy conservation standards rulemaking, DOE may consider and propose additional criteria to further specify the subset of water heaters which would have to comply with potential amended standards using the high temperature test method. This is because there could be specific cases when a water heater would reach a

higher storage tank temperature in a way that does not necessarily increase the delivery capacity over the course of an average use cycle. For example, a user may choose to use an elevated setpoint for storage temperature, but with a delivery temperature equal to this setpoint. In such a case where a higher delivery temperature is actually desired, because no cold water mixing is occurring at the outlet, there is no increase in the volume of hot water that can be provided to the home. Therefore, in its accompanying energy conservation standards rulemaking for consumer water heaters, DOE will consider specifying what user-controllable tank temperature settings might actually constitute "delivery capacity boosting." Additionally, DOE will also consider the length of time these settings may be in use to determine which types of temperature settings would result in capacity boosting over an average daily use cycle.

Once again, because high temperature testing may cause ratings for certain electric resistance storage water heaters to decrease, DOE is not requiring the use of these test provisions until the compliance date of any new energy conservation standards addressing such water heaters (*i.e.*, as part of the separate rulemakings for consumer water heaters). After the effective date of this final rule and before the compliance date of an amended standards final rule, manufacturers of certain electric resistance storage water heaters will be allowed to use the high temperature test method voluntarily to make additional representations of performance in high-temperature mode.

2. Very Small Draw Pattern Flow Rate

Section 5.4.1 of appendix E states that if the Max GPM is less than 1.7 gpm (6.4 L/min), then the very small draw pattern must be used during the 24-hour simulated-use test. Section 5.5 of appendix E states that, for the very small draw pattern, if the water heater has a Max GPM rating less than 1 gpm (3.8 L/min), then all draws shall be implemented at a flow rate equal to the rated Max GPM.

As discussed in the January 2022 NOPR, DOE has identified flow-activated water heaters that are designed to deliver water at the set point temperature of 125 °F ±5 °F (51.7 °C ±2.8 °C) that is required by section 2.5 of appendix E at a flow rate well below 1 gpm (3.8 L/min). For these products, the second draw of the very small draw pattern requires 1 gallon to be removed at the rated Max GPM, and the pattern requires the third draw to start five minutes after the initiation of the

second draw. However, any rated Max GPM less than or equal to 0.2 gpm (0.76 L/min) will result in the second draw lasting more than five minutes and past the start time of the third draw. To clarify the appropriate method of testing these products, DOE proposed to amend the very small draw pattern description to state that when a draw extends beyond the start time of a subsequent draw, that the subsequent draw will start after the required volume of the previous draw has been delivered. 87 FR 1554, 1582 (Jan. 11, 2022).

DOE did not receive any comments in response to this proposal, so, therefore, in this final rule, DOE is adopting the amendment to appendix E as proposed in the January 2022 NOPR for the reasons previously stated.

3. Low-Temperature Water Heaters

Low-temperature water heaters (discussed further in section III.A.4.b of this document) are flow-activated products that do not deliver temperatures within the required set point temperature range of 125 °F ±5 °F when tested according to the supply water temperature and flow rate requirements of appendix E. These products are typically suited for point-of-use (POU) applications where the outlet water is minimally tempered prior to delivery through the faucet (typically marketed as "handwashing" or "POU water heaters"). However, because these products cannot meet the outlet temperature requirements in appendix E, DOE is establishing new provisions to address these products.

One primary concern identified in this rulemaking is that these units typically have low heating rates, which currently requires the testing agency to reduce the flow rate in order to be able to achieve the outlet temperature within the set point temperature range. However, these units have a minimum activation flow rate below which the unit shuts off. To the extent that a unit would stop heating water when the flow rate is too low, there may be no flow rate at which the unit would operate and deliver water at the outlet temperature required under section 2.5 of appendix E. In response to the April 2020 RFI, commenters generally indicated that DOE should adopt provisions to use a lower setpoint temperature for low-temperature water heaters. 87 FR 1554, 1582 (Jan. 11, 2022).

For the reasons explained in further detail in the January 2022 NOPR, DOE proposed that low-temperature water heaters be tested at the maximum delivery temperature when using the flow rate requirements already

established in appendix E. Specifically, lowering the flow rate in order to establish a delivery temperature of 125 °F may not be feasible for these products because the flow rate may be so low that the water heater does not activate. DOE tentatively determined that lowering the set point temperature for low-temperature water heaters to their maximum possible delivery temperature would permit these water heaters to be tested appropriately and in a manner that would produce representative test results. 87 FR 1554, 1582–1583 (Jan. 11, 2022).

In commenting on this issue, BWC requested that DOE further assess differences in testing and ratings between electric instantaneous water heaters and low-temperature water heaters. (BWC, No. 33 at p. 8)

In response, DOE will continue to assess the impact of the test procedure provision in section 5.2.2 of appendix E on ratings for low-temperature water heaters as more of these products enter the market and are certified, but at this time, DOE is adopting these provisions in order to set forth a repeatable, representative approach to testing such products. Currently, there is no appendix E test method to test low-temperature water heaters, and, therefore, ratings for low-temperature water heaters are not possible until the effective date of this final rule. DOE is distinguishing low-temperature water heaters from other electric instantaneous water heaters mainly on the inability to reach the standardized outlet water temperatures under the appendix E test procedure. DOE will consider potential impacts on UEF ratings in its concurrent energy conservation standards rulemaking (*see* Docket No. EERE–2017–BT–STD–0019).

4. Delivery Temperature for Flow-Activated Water Heaters

In providing comments in response to the January 2022 NOPR, AET introduced a new topic for DOE to consider when amending the test procedure for consumer water heaters and residential-duty commercial water heaters. AET indicated that the test procedure needs to further clarify the process for setting the delivery temperature for flow-activated water heaters. The commenter argued that such clarification is necessary because the DOE test procedure simply says to initiate normal operation of the water heater at the design power rating. AET stated that, when operating flow-activated water heaters at their maximum heating rate, outlet temperature can be controlled two different ways: (1) adjust some

thermostat, and/or (2) adjust flow rate; since the instructions do not specify a flow rate at which to set the thermostat, it is theoretically possible to set the thermostat to a very high temperature, and then adjust the flow rate so that the unit only delivers the desired 125 °F outlet temperature. AET claimed that this would allow the water heater to deliver much hotter temperatures when the flow rate is less than the flow rate needed to deliver 125 °F when operating at maximum heating rate. AET recommended to amend the test procedure so as to provide instructions that the flow rate for draws should be 90 percent of the theoretically calculated maximum flow rate that could be achieved when operating at a full heating rate and delivering the required 125 °F outlet temperature in order to ensure that this temperature is consistent. (AET, No. 29 at p. 11)

On this issue, DOE notes that section 5.2.2.1 of appendix E, “*Flow-Activated Water Heaters, including certain instantaneous water heaters and certain storage-type water heaters*,” instructs the test agency to first initiate normal operation of the water heater at the full input rating for electric water heaters and at the maximum firing rate specified by the manufacturer for gas or oil water heaters. Section 5.2.2.1 then states that the test agency must monitor the discharge water temperature and set to a value of 125 °F \pm 5 °F (51.7 °C \pm 2.8 °C) in accordance with the manufacturer’s instructions. If the water heater is not capable of providing this discharge temperature when the flow rate is 1.7 gallons \pm 0.25 gallons per minute (6.4 liters \pm 0.95 liters per minute), then the flow rate is adjusted as necessary to achieve the specified discharge water temperature. Once the proper temperature control setting is achieved, the setting must remain fixed for the duration of the maximum GPM test and the simulated-use test.

In response to AET’s comment, DOE notes that the current appendix E test instructions specify that the flow rate for setting the discharge water temperature is 1.7 gallons \pm 0.25 gallons per minute (6.4 liters \pm 0.95 liters per minute). If a discharge temperature of 125 °F \pm 5 °F is not possible at that flow rate, the test method allows for the flow rate to be varied only to the extent necessary to achieve a discharge temperature of 125 °F \pm 5 °F. Therefore, DOE has determined that the current instruction is explicit enough for the delivery temperature setting to be conducted in a repeatable and reproducible manner.

5. Heat Pump Water Heaters

In this rulemaking, DOE has sought to address multiple test procedure provisions related to heat pump water heaters. In section III.A.2 of this final rule, DOE discusses the scope of applicability of the appendix E test procedure to heat pump water heaters designed for residential applications. Section III.C.7 of this document describes the new optional test conditions being allowed for heat pump water heaters for voluntary representations of E_x based on NEEA’s Advanced Water Heating Specification. Additionally, DOE is amending ambient air condition tolerances for heat pump water heater testing because air-source heat pumps exchange latent and sensible heat⁷³ with the surrounding air, and, thus, the water heater’s normal operation will have a tangible impact on air temperature and moisture content (*see* section III.C.4 of this document). Furthermore, there are other requirements being established for the test set-up and installation of split-system heat pump water heaters and circulating heat pump water heaters (*see* sections III.D.1 and III.D.4 of this document).

In addition to these topics, DOE has evaluated the draw patterns for conducting the 24-hour simulated-use test on heat pump water heaters with back-up electric resistance heating elements. In the present market, consumer heat pump water heaters are typically “integrated,” with the air-source heat pump and storage tank built together into one assembly. This “typical” consumer heat pump water heater uses electricity and has back-up electric resistance elements within the storage tank. Heating water with the heat pump components is more efficient than heating water with the back-up resistance elements. Therefore, water heaters with controls that prioritize heat pump water heating over resistance element water heating will operate more efficiently than water heaters that do not prioritize heat pump water heating or that do not prioritize heat pump water heating to the same extent.

In response to the April 2020 RFI, the Joint Commenters suggested modifying the test procedure to reflect the effectiveness of controls in minimizing use of the resistance element in heat pump water heaters, stating this modification would improve the

⁷³ “Sensible heat” refers to heat that is exchanged with surrounding air that is detectable by measuring the change in temperature of the air, as it does not change the moisture content of the air. “Latent heat” refers to heat that is exchanged when moisture in the air is condensed into liquid water (*i.e.*, at the evaporator of a heat pump water heater).

representativeness of the test procedure and create new incentives for manufacturers to develop products that provide increased savings for consumers. As noted in the January 2022 NOPR, no suggestion was provided on how to better reflect the use of controls to minimize element usage. 87 FR 1554, 1583 (Jan. 11, 2022).

In the January 2022 NOPR, DOE noted that its test data indicate that most (or possibly all) heat pump water heater models available on the market currently operate without activating the electric elements during the 24-hour simulated-use test under the current appendix E test procedure. DOE argued that although element usage during the test could be forced through a more aggressive draw pattern (*i.e.*, longer or more frequent draws designed to deplete the water heater and require more hot water than the heat pump alone could keep up with), the draw patterns are required to be representative of actual use. Therefore, designing the draw pattern with the goal of forcing resistance element use would not be representative of typical use. 87 FR 1554, 1583 (Jan. 11, 2022).

In commenting on this issue in response to the January 2022 NOPR, the ASAP, ACEEE and NCLC once again encouraged DOE to evaluate whether current draw patterns are representative of real-world conditions for heat pump water heaters. The ASAP, ACEEE and NCLC noted that investigations conducted by NEEA⁷⁴ indicate that electric resistance elements are activated more frequently in heat pump water heaters than DOE observed in its testing. Specifically, ASAP, ACEEE and NCLC pointed to the finding in the NEEA study that the average annual proportion of total input energy that was provided by resistance heat ranged from 4 to 45 percent, depending on the water heater model and location of installation. (ASAP, ACEEE, and NCLC, No. 34 at p. 2) However, DOE did not receive any additional comments in this rulemaking providing any specific approach to testing heat pump water heaters with back-up electric resistance elements in a more representative manner.

In response, DOE notes that the 2015 study by NEEA relies on data collected in a limited geographical area within the U.S.—namely, the Pacific Northwest—and the results may not be representative of installations across the

U.S, which is the requisite benchmark for a Federal test procedure. For example, one condition for electric resistance back-up is when the ambient air temperature is below the low-temperature cut-out of the compressor (*e.g.*, 45 °F), and this is more likely to occur in northern climates than it is to occur across the country as a whole. Nevertheless, the study finding demonstrated a substantial range of electric resistance contribution, such that it remains unclear whether an amended draw pattern would be more representative.

The CA IOUs did, however, suggest that DOE should consider any distinguishing characteristics of 120-volt heat pump water heaters that might require changes to the test procedure to represent their real-world performance accurately. (CA IOUs, No. 36 at p. 4) In response to the CA IOUs, within the context of back-up element usage, early indications suggest that not all 120-volt heat pump water heaters will employ back-up electric resistance heating elements due to limitations on a 120-volt circuit, but this market is still evolving. As of this final rule, there are only a limited number of commercially-available 120-volt heat pump water heaters, so DOE has determined that it is premature to establish specific testing requirements for 120-volt heat pump water heaters at this time. Without adequate test data from these products, there is uncertainty as to what, if any, specific requirements for 120-volt heat pump water heaters would be appropriate.

Therefore, after considering these comments and the lack of available data on this topic, DOE has decided to maintain the current language in section 5.1 of appendix E and is not adopting draw patterns specific to any type of heat pump water heater. Accordingly, the draw patterns for electric water heaters generally will continue to apply to these products. DOE will continue to collect information on this topic to inform a future test procedure rulemaking.

6. Draw Pattern for Commercial Applications

In response to the April 2020 RFI and as discussed in the January 2022 NOPR, EEI suggested DOE consider a test procedure for consumer water heaters used in commercial applications that includes a draw pattern more demanding than the “high” draw pattern, which is currently the draw pattern with the largest amount of delivered water in the appendix E test procedure. 87 FR 1554, 1575–1576 (Jan. 11, 2022).

In the January 2022 NOPR, DOE stated that 42 U.S.C. 6293(b)(3), in relevant part, requires that any test procedures prescribed or amended shall be reasonably designed to produce test results which measure energy efficiency of a covered product during a representative average use cycle or period of use. Consumer water heaters are designed for use in residential applications, and as such, a draw pattern representative of a commercial installation would not be representative of the product’s average use cycle or period of use. For these reasons, DOE declined to propose a draw pattern with a delivered volume greater than the high draw pattern in appendix E. 87 FR 1554, 1576 (Jan. 11, 2022).

BWC agreed that there is no need for a draw pattern above “high draw,” since the high draw pattern adequately addresses products that have high hot water deliverability within the scope of the test procedure. (BWC, No. 33 at p. 6)

As such, DOE is not adding another draw pattern to the appendix E test procedure in this final rule for the reasons previously stated.

7. Method for Determining Internal Tank Temperature for Certain Water Heaters

Section 4.5 of appendix E provides the procedure for measuring the internal storage tank temperature for water heaters with a rated storage volume at or above 2 gallons. Section 4.5 of appendix E specifies that the thermocouples be inserted into the storage tank of a water heater through either the anodic device opening, the temperature and pressure relief valve, or the outlet water line. However, DOE has identified consumer water heaters with physical attributes that make measuring internal storage tank temperature difficult, such as water heaters that have a built-in mixing valve and no anodic device, or that have a large heat exchanger that does not accommodate insertion of a thermocouple tube. In this rulemaking, DOE sought suggestions from stakeholders on how the internal storage tank temperature should be measured for these types of designs. After considering the comments received, DOE is amending the appendix E test procedure to specify a method for determining the internal mean tank temperature for such products, as discussed in detail later in this section.

In response to the April 2020 RFI and as discussed in the January 2022 NOPR, BWC recommended a “drain-down” approach to address water heaters that cannot have their internal storage tank

⁷⁴ ASAP, ACEEE and NCLC cited NEEA’s 2015 Heat Pump Water Heater Model Validation Study, (Report #E15–306), found online at: ecotopewebstorage.s3.amazonaws.com/2015_001_1_HPWHModelVal.pdf (Last accessed on Sept. 13, 2022).

temperatures measured directly (a position echoed by Rheem). More specifically, BWC's suggested approach consisted of the following: (1) After the FHR test, purging the water heater with inlet water at $58\text{ }^{\circ}\text{F} \pm 2\text{ }^{\circ}\text{F}$ to establish the mean tank temperature at the beginning of the 24-hour simulated-use test; (2) allowing the water heater to heat up to the original thermostat setting and recording the energy used to do so; (3) running the appropriate draw pattern, then fully draining the water heater by gravity, while measuring the mass and temperature of the water; and (4) calculating the energy change as: energy change = mass \times specific heat \times the difference between the average end temperature and the beginning temperature just after the $58\text{ }^{\circ}\text{F}$ purge. Rheem also supported a drain-down method, whereby the entire volume would be removed and the temperature measured at the end of the 24-hour test. 87 FR 1554, 1586 (Jan. 11, 2022).

However, DOE's primary concern with the suggested drain-down approach was that it cannot be conducted at every stage during the 24-hour simulated-use test when the mean tank temperature measurement is required. As discussed in the January 2022 NOPR, the procedures recommended by BWC and Rheem could provide an estimate of the mean tank temperature at the start and end of the 24-hour simulated-use test but would not provide an estimate at the

end of the first recovery period, the start and end of the standby period, or an average over the standby period, all of which are required for determining UEF. Instead of BWC's drain-down approach, DOE initially proposed a methodology with a modified approach, wherein the mean tank temperature would be estimated as the average of the inlet water temperature and the outlet water temperature each time a mean tank temperature measurement was required. This method assumes that the stored water gradually (*i.e.*, linearly) increases in temperature either from the bottom of the tank to the top, or the further the water is into the heat exchanger from the water inlet, depending on the design of the water heater being tested. As the exact internal dimensions of the storage tank or heat exchanger cannot be known for every water heater, DOE reasoned that the linear assumption is the most representative of the water heater market as a whole. 87 FR 1554, 1586–1587 (Jan. 11, 2022).

In response to DOE's proposal, AHRI, A.O. Smith, and BWC indicated that the linear temperature gradient assumption inherent to the proposed methodology in the January 2022 NOPR is incorrect, based on the companies' own test results. (AHRI, No. 40 at p. 5; A.O. Smith, No. 37 at pp. 5–6; BWC, No. 33 at p. 10) In contrast, Rheem supported DOE's proposed linear temperature gradient assumption. (Rheem, No. 31 at

p. 4) None of the comments received in response to the January 2022 NOPR suggested an alternative approach, so in the July 2022 SNOPR, DOE revised its proposal to incorporate aspects of BWC's method but included additional methods to estimate the intermediate temperatures required for efficiency calculations. 87 FR 42270, 42283–42284 (July 14, 2022).

In the July 2022 SNOPR, DOE proposed the following methodology for water heaters with rated storage volumes greater than or equal to 2 gallons that are unable to have their internal tank temperatures measured using thermocouples:

(1) After the FHR test (for non-flow-activated products) or Max GPM test (for flow-activated products), allow the water heater to fully recover.

(2) When cut-out occurs, deactivate the burner, compressor, and/or electrical heating elements.

(3) Remove the hot water from the tank by performing a continuous draw, while measuring the outlet water temperature at 3-second intervals, until the outlet water temperature is within $2\text{ }^{\circ}\text{F}$ of the inlet water temperature for five consecutive readings. Perform the draw at a flow rate of 3.0 gallons per minute (± 0.25 gallons per minute). Compute the mean tank temperature, \bar{T}_{st} , as follows and assign this value as \bar{T}_0 , $\bar{T}_{su,0}$, and $\bar{T}_{max,1}$:

$$\bar{T}_{st} = T_p - \frac{v_{out,p}}{V_{st}} \times \tau_p (\bar{T}_{in,p} - \bar{T}_{out,p})$$

Where:

\bar{T}_{st} = the estimated average internal storage tank temperature.

T_p = the average of the inlet and the outlet water temperatures at the end of the period defined by τ_p .

$v_{out,p}$ = the average flow rate during the period.

V_{st} = the rated storage volume of the water heater.

τ_p = the duration of the period, determined by the length of time taken for the outlet water temperature to be within $2\text{ }^{\circ}\text{F}$ of the inlet water temperature for 15 consecutive seconds. The duration of the period shall include the 15-second stabilization period.

$\bar{T}_{in,p}$ = the average of the inlet water temperatures during the period.

$\bar{T}_{out,p}$ = the average of the outlet water temperatures during the period.

(4) Re-activate the burner, compressor, and/or electrical elements and perform the 24-hour simulated use test as instructed in section 5.4 of appendix E.

(5) The standby period will start at five minutes after the end of the first recovery period after the last draw of the simulated-use test. The standby period shall last eight hours, so testing will extend beyond the 24-hour duration of the simulated-use test. At the end of the final standby measurement, remove water from the tank once again as in step #3, including computing the value of mean tank temperature. This calculated mean tank temperature is then assigned as $\bar{T}_{su,f}$ and \bar{T}_{24} .

(6) Determine $\bar{T}_{t,sty,1}$ as the average of $\bar{T}_{su,0}$ and $\bar{T}_{su,f}$.

The revised proposal relied on a different assumption—supported by DOE's test data—that, for typical storage-type water heaters, \bar{T}_0 , $\bar{T}_{su,0}$, and $\bar{T}_{max,1}$ are similar in that they represent temperatures near the cut-out control temperature. Furthermore, the mean tank temperature at the end of the standby period, $\bar{T}_{su,f}$, can also be

measured by removing water and measuring its temperature at the end of a sufficiently long standby period at the end of the test, and this value could also approximate \bar{T}_{24} . 87 FR 42270, 42284–42285 (July 14, 2022).

In response to the July 2022 SNOPR, AHRI stated that manufacturers would need additional time to complete testing to verify the proposed equations and requested that DOE provide additional data and evidence that the method is appropriate before adopting it. Further, AHRI asked that DOE specify the correct procedure if the initial recovery period extends beyond the start of the second draw. (AHRI, No. 55 at p. 8) A.O. Smith expressed support for the revised proposal in the SNOPR, but the commenter added that manufacturers will need to work with the Department as additional testing on the identified products ensues, should this proposed change become part of any final rule.

(A.O. Smith, No. 51 at p. 9) BWC stated that the equation presented in the SNOPIR is an improvement over the January 2022 NOPR proposal that will more effectively measure internal tank temperatures. However, BWC also commented that it has insufficient data to support or reject some elements of the proposal, and the company provided as an example the DOE's assumption made in the SNOPIR proposal that \bar{T}_{\max} and \bar{T}_{su} are similar. BWC explained that it would like to conduct additional testing before commenting further. (BWC, No. 48 at p. 5)

Rheem noted that the procedure as proposed in section 5.4.2.2 of the proposed appendix E does not align with steps 1 and 2 of the preamble. Specifically, Rheem argued that the preamble states that after the FHR or Max GPM test, the unit should be allowed to fully recover, and then, one would deactivate the burner, compressor, and/or elements, and remove the hot water from the tank, which would result in a comparatively "hot" water temperature that is representative of a $\bar{T}_{\max,1}$ or $\bar{T}_{\text{su},0}$ value, both of which are measured after a draw and that is normally followed by a recovery; however, section 5.4.2.2 of the proposed appendix E states that a 1-hour idle period is to be performed prior to draining the tank, which would result in a comparatively "low" water temperature that is representative of \bar{T}_0 , a measurement taken after an idle period where no energy was added to the tank. Rheem requested DOE clarify which method should be used. (Rheem, No. 47 at p. 8) Rheem also requested DOE clarify when a soak-in period is required when testing a water heater that cannot have the internal storage tank temperature directly measured, and specifically, the commenter asked whether a soak-in period is required between draining the tank after FHR testing and starting the 24-hour simulated use portion of the test. (Rheem, No. 47 at p. 8)

Rheem stated that the proposed procedure drains water from the unit at a flow rate of 3 gpm until the inlet and outlet temperatures match, which means all energy in the water and tank/heat exchanger has been removed from the unit under test. Rheem requested that DOE clarify that this is the intent of the procedure and suggested that as an alternative, since the storage volume is known, the test could simply remove the stored water and estimate the internal tank temperature using the proposed equation. (Rheem, No. 47 at p. 8) Rheem also recommended that the

flow rate used for draining the tank be the flow rate of draw 1 of the 24-hour simulated-use test and that the temperatures be measured throughout the draw, not just after the first 15 seconds, stating that the flow rate of 3 gpm may be too fast for some water heaters or would not account for the true energy content of the internal water. (Rheem, No. 47 at p. 8) Lastly, Rheem requested that DOE provide the derivation of the \bar{T}_{st} equation, stating that the derivation and assumptions are not immediately apparent. (Rheem, No. 47 at p. 9)

In response, DOE provides the following clarifications. With respect to AHRI's request for clarification of the test procedure in terms of whether the initial recovery period extends beyond the start of the second draw, DOE notes that the tank would only be drained of hot water twice regardless of when the initial recovery period ends—once after recovery after the FHR or max GPM test, and once at the end of the standby period at the end of the test. The mean tank temperature determined during the first draining would be used to approximate $\bar{T}_{\max,1}$ regardless of when that actually occurs during the test, as DOE expects that $\bar{T}_{\max,1}$, which occurs after the first recovery period ends, would not vary significantly depending on whether it occurs after the second draw. Regarding Rheem's request for a clarification of whether a 1-hour idle period is required before the first time drawing off all of the hot water in the tank, DOE clarifies that the 1-hour idle period is required, as was presented in the regulatory text in the SNOPIR. As shown in Table III.3 which follows, \bar{T}_0 measurements taken after the 1-hour idle period are comparable to $\bar{T}_{\max,1}$ and $\bar{T}_{\text{su},f}$ measurements. In addition, for tanks for which the internal tank temperature cannot be directly measured, the same soak-in provisions apply as those that apply generally as described in sections 5.2.4 and 5.4.2 of appendix E.

Regarding Rheem's suggestion to remove volume of stored water in the tank and use the average temperature of that water to represent the measured mean tank temperature, DOE notes that when drawing off hot water through the hot water outlet, cold water is introduced into the tank which could mix with the stored water. Removing only the stored volume in the tank could result in an artificially low mean tank temperature due to the cold inlet water mixing with the stored water, whereas the proposed approach accounts for all of the thermal energy

contained in the tank to estimate the temperature of the stored water prior to removing the hot water from the tank. A valid estimate of the tank temperature could be obtained by shutting off the supply (inlet) water line and draining the tank by gravity using the drain at the bottom. However, such an approach would likely require additional equipment for the test set-up, such as an additional temperature sensor, a flowmeter to measure the water leaving through the drain, and a flow control valve to manage the water exiting the drain, equipment not currently included in the typical test set-up. In addition, DOE has found that for some water heaters, even after draining by gravity, a small volume of water remains in the bottom of the tank, which would be difficult to account for under such an approach. After considering these comments, DOE has concluded that the methodology proposed in the SNOPIR would not require changes to the test set-up and, therefore, would be less burdensome.

DOE agrees with Rheem that a flow rate of 3.0 gpm may not be appropriate for all water heaters, and in particular it may be too high for temperature sampling rates to accurately estimate the mean tank temperature of smaller water heaters. Thus, DOE is adopting Rheem's suggestion to withdraw water at a flow rate equal to the flow rate of the first draw in the applicable draw pattern. DOE also agrees with Rheem that starting the measurements immediately, rather than after 15 seconds, would provide a more accurate representation of tank temperature, and, therefore, the Department is adopting that recommendation as well.

In response to these comments, DOE re-evaluated its own test data in order to further validate the method for determining internal tank temperature outlined above. Underpinning this method is an assumption that during a simulated use test, the mean tank temperatures that occur after the tank has been in standby for some time, $\bar{T}_{\text{su},f}$ and \bar{T}_{24} , are typically very similar to each other, and that the tank temperatures measured soon after a recovery and subsequent "cut-out", $\bar{T}_{\text{su},0}$, \bar{T}_0 , and $\bar{T}_{\max,1}$, are also typically very similar to each other. This is because water heaters with thermostats have a control band near the setpoint which directs the cut-in and cut-out to occur once the setpoint is reached. Table III.2 and Table III.3 below show the mean tank temperatures for a sample of 29 consumer water heaters.

TABLE III.2— $\bar{T}_{su,f}$ AND \bar{T}_{24} VALUES FOR WATER HEATERS TESTED BY DOE

Test No.	Product type *	Draw pattern	$\bar{T}_{su,f}$ (°F)	\bar{T}_{24} (°F)	Difference between $\bar{T}_{su,f}$ and \bar{T}_{24} (°F)
1	ES	Low	125.2	127.9	2.72
2	ES	Medium	121.2	116.7	4.50
3	ES	Medium	124.2	123.8	0.40
4	ES	Medium	122.7	122.1	0.56
5	ES	Medium	120.2	121.6	1.44
6	ES	Medium	123.7	120.7	3.04
7	ES	Medium	120.1	119.5	0.60
8	ES	Low	121.7	122.5	0.78
9	ES	Medium	124.2	117.8	6.42
10	ES	Medium	127.1	126.8	0.27
11	ES	High	124.4	122.9	1.54
12	ES	Low	123.4	120.6	2.83
13	ES	Medium	121.1	116.0	5.13
14	ES	Medium	121.5	119.5	1.96
15	ES	Medium	117.4	119.8	2.42
16	ES	Medium	117.5	123.9	6.43
17	ES	Medium	125.1	124.2	0.93
18	ES	Low	121.3	120.4	0.91
19	ES	Medium	119.5	119.4	0.10
20	ES	Medium	122.7	114.5	8.17
21	ES	Medium	116.3	124.5	8.16
22	ES	Medium	112.8	118.2	5.38
23	ES	Medium	126.0	135.8	9.83
24	ES	Medium	124.9	122.7	2.22
25	ES	Low	124.1	122.4	1.72
26	GS	Medium	125.7	126.3	0.60
27	GS	High	125.7	126.3	0.60
28	GS	Medium	125.4	132.8	7.40
29	GS	High	128.9	130.6	1.70
Minimum					0.10
Arithmetic Mean					3.06
Maximum					9.83

* Note: “ES” denotes an electric storage water heater, and “GS” denotes a gas-fired storage water heater.

TABLE III.3— \bar{T}_0 , $\bar{T}_{max,1}$, AND $\bar{T}_{su,0}$ VALUES FOR WATER HEATERS TESTED BY DOE

Test No.	Product type *	Draw pattern	\bar{T}_0 (°F)	$\bar{T}_{max,1}$ (°F)	$\bar{T}_{su,0}$ (°F)	Maximum difference between \bar{T}_0 , $\bar{T}_{max,1}$ and $\bar{T}_{su,0}$ (°F)
1	ES	Low	118.2	116.8	114.0	4.20
2	ES	Medium	117.1	119.8	120.2	3.07
3	ES	Medium	119.0	116.0	119.6	3.60
4	ES	Medium	118.3	119.6	120.2	1.95
5	ES	Medium	124.2	117.8	119.5	6.36
6	ES	Medium	117.7	118.7	119.8	2.13
7	ES	Medium	119.2	116.2	117.5	3.02
8	ES	Low	122.0	117.1	115.6	6.40
9	ES	Medium	124.4	121.3	121.1	3.33
10	ES	Medium	122.4	120.5	122.5	2.00
11	ES	High	120.8	121.1	122.7	1.91
12	ES	Low	123.8	120.7	124.5	3.80
13	ES	Medium	116.8	121.9	119.5	5.13
14	ES	Medium	120.8	126.0	125.2	5.17
15	ES	Medium	121.8	121.2	121.6	0.56
16	ES	Medium	120.6	121.8	122.6	1.98
17	ES	Medium	121.1	118.6	121.4	2.80
18	ES	Low	121.0	121.4	118.6	2.80
19	ES	Medium	122.5	115.3	116.5	7.20
20	ES	Medium	120.1	124.1	125.8	5.75
21	ES	Medium	124.5	116.7	118.8	7.80
22	ES	Medium	122.7	113.6	114.9	9.05
23	ES	Medium	125.6	120.4	122.2	5.23
24	ES	Medium	124.6	124.4	125.4	1.00
25	ES	Low	123.4	118.4	119.1	4.97

TABLE III.3— \bar{T}_0 , $\bar{T}_{\max,1}$, AND $\bar{T}_{\text{su},0}$ VALUES FOR WATER HEATERS TESTED BY DOE—Continued

Test No.	Product type *	Draw pattern	\bar{T}_0 (°F)	$\bar{T}_{\max,1}$ (°F)	$\bar{T}_{\text{su},0}$ (°F)	Maximum difference between \bar{T}_0 , $\bar{T}_{\max,1}$ and $\bar{T}_{\text{su},0}$ (°F)
26	GS	Medium	125.0	126.0	128.0	3.00
27	GS	High	126.1	125.2	131.8	6.60
28	GS	Medium	124.1	128.7	131.4	7.30
29	GS	High	124.7	123.8	129.8	6.00
Minimum						0.5656
Arithmetic Mean						4.28
Maximum						9.05

* Note: “ES” denotes an electric storage water heater, and “GS” denotes a gas-fired storage water heater.

On average, across multiple product classes, the temperatures $\bar{T}_{\text{su},f}$ and \bar{T}_{24} vary about 3 °F from each other. Similarly, the temperatures \bar{T}_0 , $\bar{T}_{\max,1}$, and $\bar{T}_{\text{su},0}$ vary about 4 °F from for each other. In both cases, the range of variability between the mean tank temperatures of the water heaters in the sample was from less than 1 °F up to 9 °F. Based on these data, DOE has concluded that both the temperatures are similar enough among each other that grouping them together for determining internal storage tank temperature, as proposed in the July 2022 SNOPR, is reasonably valid when there is no direct alternative of measuring these temperatures. As such, in this final rule, DOE is adopting the method for determining internal storage tank temperature as proposed in the July 2022 SNOPR with the modifications discussed in the preceding paragraphs.

In response to Rheem’s request for a derivation of the \bar{T}_{st} equation, DOE notes that it was derived based on the assumption that the withdrawn water has the same amount of energy as the water stored in the tank, since there would be no energy input (*i.e.*, the burner, compressor, and/or electrical heating elements are deactivated) and assuming minimal losses over the course of the draw. Specifically, DOE sought to determine the initial mean tank temperature of the water, denoted by \bar{T}_{st} . The energy in the withdrawn water can be calculated based on its mass, specific heat, and the temperature difference between the water and the ambient air, which are all parameters that can be measured or determined directly as the water is being withdrawn from the tank. As noted previously, this value can then be assumed to be equal to the energy that would have been stored in the tank before withdrawing the water, which can also be determined based on its mass, specific heat, and temperature difference. The mass of

water in the tank can be determined based on the stored volume and density; the specific heat can be assumed as 1 Btu/lb°F, and the temperature difference can be calculated as \bar{T}_{st} minus the ambient temperature. As \bar{T}_{st} is the only unknown, the equation can be rearranged to solve for \bar{T}_{st} to provide an estimate of the mean tank temperature prior to withdrawing water.

In response to requests made by AHRI, A.O. Smith, and BWC for additional time to conduct testing, DOE reiterates that test procedures must be established for all products within the scope of this rulemaking. DOE is finalizing this method for determining internal tank temperature based on an evaluation of its own test data, and the Department does not believe it is necessary to delay publication of this final rule for additional data to be collected on this topic. Water heaters with rated storage volumes greater than or equal to 2 gallons whose internal tank temperatures cannot be measured using thermocouples meet the definition of “consumer water heater” as codified at 10 CFR 430.2; therefore, they are covered products and must have applicable test procedures. In this case, based on information from its own testing, DOE is establishing these test procedures in this final rule.

8. Alternate Order 24-Hour Simulated-Use Test

As discussed in the January 2022 NOPR, DOE received comments at the RFI stage from SMTI recommending that DOE move the standby loss period of the test to the beginning of the 24-hour simulated-use test and to start the first draw at the 6-hour mark, based on claims that water heaters with large storage volumes but low input rates (*e.g.*, storage-type heat pump water heaters) may receive artificially low recovery efficiency results from the current test method with the standby

loss period occurring in the middle of the test. 87 FR 1554, 1587 (Jan. 11, 2022).

In the January 2022 NOPR, DOE noted that as a general matter, the result of the standby period has a negligible effect on UEF, so moving the standby period to the start of the rest would likewise have a negligible effect on UEF in terms of improving the accuracy of the standby loss calculations for most water heaters. However, DOE agreed that moving the standby period to the start of the test may affect the recovery efficiency of the large-volume/low-input-rate water heaters described by SMTI, and a large change in recovery efficiency can have a significant effect on UEF. DOE tentatively determined that the first recovery is rarely delayed past the first draw (based on DOE’s own test data), but if the order of the 24-hour simulated-use test were to be changed (*i.e.*, placing the standby loss period at the beginning), all water heaters on the market would need to be retested. Therefore, DOE declined to propose such a change, as the associated burden on manufacturers to retest would result in a potential increase in accuracy for only a small subset of the consumer water heaters available on the market. 87 FR 1554, 1587 (Jan. 11, 2022).

DOE did not receive further comments on this topic. Therefore, DOE has decided not to move the standby period to the start of the 24-hour simulated-use test because such amendment would be unduly burdensome on all manufacturers, as they would be required to retest all of their products, even though the representativeness of the efficiency results would be improved for only a small subset of water heaters.

F. Computations

1. Mass Calculations

In sections 6.3.5 and 6.4.2 of appendix E, the mass withdrawn during

each draw (M_i) is used to calculate the daily energy consumption of the heated water at the measured average temperature rise across the water heater (Q_{HW}). However, neither section includes a description of how to calculate the mass withdrawn for tests in which the mass is indirectly determined using density and volume measurements. In the April 2020 RFI, DOE requested feedback on whether to update the consumer water heater test procedure to include a description of how to calculate the mass withdrawn from each draw in cases where mass is indirectly determined using density and volume measurements. 85 FR 21104, 21113 (April 16, 2020). Stakeholders generally supported including an equation in the computations of appendix E, with many suggesting that DOE adopt the calculations in the AHRI Operations Manual for Residential Water Heater Certification Program. 87 FR 1554, 1582 (Jan. 11, 2022).

In the January 2022 NOPR, DOE proposed that the volume at the outlet would be multiplied by the density, which would be based on the average outlet temperature measured during the draw. DOE also proposed to add procedures similar to those in the AHRI Operations Manual for Residential Water Heater Certification Program; in particular, DOE proposed to add a method of converting inlet water volume to outlet water volume using the ratio of the water densities at the inlet and outlet.⁷⁵ *Id.*

In response to the January 2022 NOPR, BWC supported DOE's proposed clarifications for calculating water mass from indirect measurements. (BWC, No. 33 at p. 8)

After carefully considering the comments, in this final rule, DOE is adopting the computations for determining water mass from indirect measurements that were proposed in the

January 2022 NOPR for the reasons previously discussed.

2. Effective Storage Volume

In this final rule, DOE is establishing provisions to calculate the effective storage volume to account for: (1) water heaters which may increase storage tank temperature to increase delivery capacity, and (2) circulating water heaters. As discussed throughout section III.E.1 of this document, raising the temperature of the water stored in the tank can increase the effective storage capacity of the water heater. Additionally, circulating water heaters are instantaneous-type water heaters that operate with a separate stored volume of water such that the actual amount of hot water that can be provided immediately (without additional heat input) is related to the volume of water stored in the circulation pipes or in the separate tank—and not the rated storage volume of the circulating water heater itself. The following subsections describe the approach used for each case.

a. Storage Water Heaters With Elevated Stored Water Temperature

In the July 2022 SNOPR, DOE addressed multiple comments regarding water heaters which boost the tank temperature in order to increase effective storage volume. (Operation in high heat mode and high temperature testing are discussed in detail in section III.E.1 of this final rule.) In particular, DOE noted there are certain consumer activities, such as filling a bathtub, for which the FHR metric and the rated storage volume metric alone do not sufficiently describe the water heater's ability to provide a large amount of hot water immediately. 87 FR 42270, 42280–42281 (July 14, 2022).

For activities such as filling a bathtub, consumers would benefit more from

knowing the effective storage volume (*i.e.*, the volume of immediately available hot water) of a water heater, whereas for activities such as taking a shower, consumers could benefit more from knowing the FHR (*i.e.*, ability to deliver hot water for an extended period of time). In particular, FHR represents one full hour of delivery and does not necessarily describe immediate hot water availability, as FHR is also impacted by the rate of recovery. In the past, rated storage volume has served as an indication of the amount of hot water immediately available. However, given the emergence of new water heater designs that allow operation in high heat mode, and the option that has existed to increase the tank temperature and install an external mixing valve, to provide additional capacity, this is no longer the case for all water heaters. Hence, in addition to FHR, DOE tentatively determined in the July 2022 SNOPR that effective storage volume would be a meaningful performance metric for consumers. *Id.*

Therefore, in the July 2022 SNOPR, DOE proposed a method to determine effective storage volume, V_{eff} (expressed in gallons or liters), at section 6.3.1.1 of appendix E. For water heaters capable of operating in high heat mode (which DOE proposed be determined by $T_{\text{max},1}$ being greater than $T_{\text{del},2}$ during the 24-hour simulated use test), DOE proposed to calculate the effective storage volume based on a volume scaling factor and data already collected during the appendix E test. *Id.* at 87 FR 42281.

DOE proposed that the volume scaling factor would be determined as follows, which is derived by comparing the thermal energy stored by the water heater when the water is heated to 125 °F to the thermal energy stored at its maximum tank temperature, using temperature data collected during the test:

$$k_V = \frac{\rho(\bar{T}_{\text{max},1}) \times C_p(\bar{T}_{\text{max},1}) \times (\bar{T}_{\text{max},1} - 67.5^\circ\text{F})}{\rho(125^\circ\text{F}) \times C_p(125^\circ\text{F}) \times (125^\circ\text{F} - 67.5^\circ\text{F})}$$

Where:

k_V is the dimensionless volume scaling factor;

$\rho(T)$ is the density of water evaluated at temperature T ;

$C_p(T)$ is the heat capacity of water evaluated at temperature T ;

$\bar{T}_{\text{max},1}$ is the maximum measured mean tank temperature after the first recovery

period of the 24-hour simulated-use test, and
67.5 °F is the average ambient temperature.
87 FR 42270, 42281 (July 14, 2022).

DOE proposed to determine the effective storage volume by multiplying the measured storage volume by k_V . *Id.*

In response to DOE's effective storage volume proposal, ASAP, ACEEE, and NRDC expressed support for DOE's

proposal to use effective storage volume as a metric for water heaters with high heat modes. (ASAP, ACEEE, and NRDC, No. 54 at pp. 2–3)

AHRI requested that DOE provide additional data and evidence supporting the proposed equations for calculating effective storage volume and stated that manufacturers would also need

⁷⁵ The AHRI Operations Manual for Residential Water Heater Certification Program specifies that

the outlet water volume is equal to the inlet water

volume times the inlet water density divided by the outlet water density.

additional time to complete testing to verify their accuracy, representativeness, and repeatability. AHRI requested that DOE specify the correct procedure to evaluate this metric where the initial recovery period extends beyond the start of the second draw in this test. (AHRI, No. 55 at pp. 7–8)

BWC requested that DOE conduct further testing for the method to determine effective storage volume, stating that manufacturers have not had enough time to conduct their own testing for this proposal. (BWC, No. 48 at pp. 3–4)

Rheem suggested that DOE may not have enough information to incorporate effective storage volume into its energy conservation standards rulemaking

without amending certification criteria because DOE is not requiring it to be reported. (Rheem, No. 47 at p. 8) Additionally, Rheem stated that models without “high heat modes” may still meet the conditions to be affected by the effective storage volume calculation, and the commenter requested that DOE clarify how to calculate effective storage volume when the first recovery period extends beyond the second draw, raising the concern that the delivery temperature can be too low as a result of this condition. (Rheem, No. 47 at p. 7)

In order to address these comments, DOE has re-evaluated its own test data to further examine the implications of the effective storage volume calculation

as proposed in the July 2022 SNOPR. In particular, DOE sought to address Rheem’s concern that the criteria which triggers effective storage volume calculation ($T_{max,1} > T_{del,2}$) may lead more models to be impacted than just those operating with an elevated tank temperature and the request for clarification on how to calculate effective storage volume in the instance that the first recovery period extends beyond the second draw. Table III.3 lists the anonymized test data DOE evaluated to address the first of these two concerns. These tests were conducted in accordance with the currently applicable appendix E test procedure, with a nominal setpoint temperature of 125 °F and no mixing valve installed.

TABLE III.3— $T_{max,1}$ AND $T_{del,2}$ VALUES FOR A SAMPLE OF WATER HEATERS

Test No.	Product type *	Draw pattern	$T_{max,1}$ (°F)	$T_{del,2}$ (°F)	$T_{max,1} - T_{del,2}$ (°F)**	$k_v > 1$ †
1	ES	Medium	116.0	124.6	-8.6	NO.
2	ES	Medium	117.8	125.8	-8.0	NO.
3	ES	Medium	121.3	122.8	-1.5	NO.
4	ES	Medium	120.4	122.6	-2.2	NO.
5	GS	Medium	126.0	128.5	-2.5	NO.
6	GS	High	125.2	127.2	-2.0	NO.
7	GS	Medium	128.7	129.5	-0.8	NO.
8	GS	High	123.8	127.0	-3.2	NO.
Minimum			116.0		-8.6	
Mean			122.4		-3.6	
Maximum			128.7		-0.8	
Std. Dev			4.3		3.0	

* Note: “ES” denotes an electric storage water heater, and “GS” denotes a gas-fired storage water heater.

** A value of +5 °F or more in this column would satisfy one of the two criteria for determining k_v to be greater than 1.

† Per the effective storage volume calculation provisions established in this final rule.

Upon further evaluation of the test data presented in Table III.3 and based on comments received, in this final rule, DOE is modifying the approach in its earlier proposal to ensure that k_v values greater than 1 are only calculated for water heaters operating with a significantly elevated tank temperature—as determined by both the difference between the storage tank temperature and the delivery temperature, as well as the storage tank temperature itself. Specifically, due to the fact that for some of the water heaters in Table III.3 $T_{max,1}$ is only slightly less than $T_{del,2}$, DOE has amended the criteria for determining k_v such that a water heater must have both $T_{max,1} > 130$ °F and $T_{max,1} > T_{del,2} + 5$ °F in order to have a k_v factor greater than 1. If these two criteria are not met, then the water heater will be assigned a k_v factor of 1 and will have an effective storage volume equal to its rated storage volume. This update to DOE’s proposed approach will ensure that effective storage volume is only calculated to be

greater than the rated storage volume for water heaters operating with a mean tank temperature that is both significantly above 125 °F and significantly above the delivered water temperature. The data show that for tests conducted at a nominal 125 °F tank temperature setpoint, a k_v greater than 1.0 is not expected. For additional reference, DOE conducted one test on a water heater set to its maximum storage tank temperature, resulting in a $T_{max,1}$ of 159.6 °F and a $T_{del,2}$ of 124.3 °F, which would cause the k_v to be equal to 1.59.

Additionally, in order to address Rheem’s concern about models for which the first recovery period extends beyond the start of the second draw, DOE has examined its own test data for water heaters exhibiting this behavior. Table III.4 lists anonymized data from 21 tests for which the first recovery period extended beyond the start of the second draw. Similar to the previous dataset, these tests were conducted at a tank temperature setpoint of 125 °F and no mixing valve installed.

DOE agrees that it would not be appropriate to base the effective storage volume calculation criteria on $T_{del,2}$ if the tank is still recovering during the second draw, because $T_{del,2}$ may be lower than it would be had the tank fully recovered. Therefore, for such cases, DOE has determined that T_0 will take the place of $T_{max,1}$, and $T_{del,1}$ will take the place of $T_{del,2}$ in the criteria specified previously. DOE has specified T_0 and $T_{del,1}$ as substitutes in this instance because they are unaffected by the timing of the first recovery period. $T_{del,1}$ is measured during the first draw of the test, which will begin prior to the start of a recovery. T_0 is measured immediately before the first draw (during which $T_{del,1}$ is measured) and before the first recovery period, and it is, therefore, more representative of internal tank temperature as a point of comparison with $T_{del,1}$ to determine whether the storage tank temperature is elevated relative to the delivery temperature. In reviewing its data for tests whose first recovery period

extended into the second draw, as shown in Table III.4, DOE found that the results using T_0 and $T_{del,1}$ are very comparable to those using $T_{max,1}$ and $T_{del,2}$, as shown in Table III.3. However, DOE is not making T_0 and $T_{del,1}$ the default variables because when T_0 is

paired with $T_{del,1}$, the delta between the two is a slightly less reliable indicator of when elevated tank temperatures actually occur, compared to the default pair of $T_{max,1}$ and $T_{del,2}$. This is evidenced by the fact that the standard deviation of the delta, $T_0 - T_{del,1}$, is

slightly higher at 3.6, than that of the default variables, $T_{max,1} - T_{del,2}$, which is 3.0. These standard deviations, along with other statistics for the test data are shown in Table III.3 and Table III.4.

TABLE III.4— T_0 AND $T_{del,1}$ VALUES FOR A SAMPLE OF WATER HEATERS WHOSE FIRST RECOVERY PERIOD EXTENDS INTO THE SECOND DRAW

Test No.	Product type	Draw pattern	T_0 (°F)	$T_{del,1}$ (°F)	$T_0 - T_{del,1}$ (°F)**	$k_v > 1$ †
1	ES	Low	118.2	122.8	-4.6	NO.
2	ES	Medium	117.1	128.7	-11.6	NO.
3	ES	Medium	118.3	123.7	-5.5	NO.
4	ES	Medium	117.7	127.7	-10.0	NO.
5	ES	Medium	119.2	125.9	-6.7	NO.
6	ES	Low	122.0	125.2	-3.2	NO.
7	ES	Medium	122.4	128.3	-6.0	NO.
8	ES	High	120.8	126.8	-6.0	NO.
9	ES	Low	123.8	125.6	-1.8	NO.
10	ES	Medium	116.8	129.5	-12.7	NO.
11	ES	Medium	120.8	123.8	-3.0	NO.
12	ES	Medium	121.8	123.9	-2.1	NO.
13	ES	Medium	120.6	123.1	-2.5	NO.
14	ES	Medium	121.1	126.6	-5.5	NO.
15	ES	Low	121.0	125.0	-4.0	NO.
16	ES	Medium	122.5	125.3	-2.8	NO.
17	ES	Medium	120.1	129.0	-9.0	NO.
18	ES	Medium	124.5	125.0	-0.5	NO.
19	ES	Medium	122.7	124.3	-1.6	NO.
20	ES	Medium	124.6	126.3	-1.7	NO.
21	ES	Low	123.4	123.0	0.4	NO.
Minimum			116.8		-12.7	
Mean			120.9		-4.8	
Maximum			124.6		0.4	
Std. Dev			2.4		3.6	

* Note: "ES" denotes an electric storage water heater.

** A value of +5 °F or more in this column would satisfy one of the two criteria for initiating calculation of k_v .

† Per the effective storage volume calculation provisions established in this final rule.

AHRI, A.O. Smith, and Rheem expressed concern that because FHR is used as a metric for other activities such as building codes, plumbing codes, and incentive programs, DOE's proposal may cause misalignment with those requirements, as well as increased burden if manufacturers were to be required to comply with metrics for both FHR and effective storage volume. (AHRI, No. 55 at p. 7; A.O. Smith, No. 51 at pp. 7–8; Rheem, No. 47 at pp. 7–8) Rheem suggested that effective storage volume is not more appropriate than FHR as a metric of thermal energy storage. (Rheem, No. 47 at p. 7) A.O. Smith and Rheem also suggested that FHR is a more meaningful metric for consumers and that effective storage volume would be confusing. (A.O. Smith, No. 51 at pp. 7–8; Rheem, No. 47 at p. 7)

In response to these comments, the Department confirms that FHR is not being phased out or fully replaced by effective storage volume in the DOE test procedure, and, therefore, this

additional metric will not cause misalignment with other programs and regulations based on FHR. As stated previously, these metrics provide different information: effective storage volume indicates the amount of hot water that can be delivered immediately without need for heat input and is correlated to the standby losses of the tank, whereas the FHR metric is determined by a test which allows the heat input to remain on and for the water heater to initiate a recovery. Additionally, manufacturer burden would be minimal because the effective storage volume can be determined based on measurements already taken during the 24-hour simulated use test.

DOE notes that in contrast to FHR, effective storage volume is capable of accounting for the increase in thermal energy associated with heating water above the intended delivery temperature in comparison with larger units storing water at conventional temperatures. It also allows consumers to compare water heaters with similar delivery

capabilities but different sizes, information which DOE considers meaningful, while avoiding the risk of backsliding for units with lower-than-normal FHRs, should FHR be used as the metric. Contrary to what these commenters suggest, DOE finds that providing a measure of effective storage volume is more likely to prevent consumer confusion due to the increased transparency it promotes by reflecting the immediate hot water capacity of the water heater for certain uses such as filling a bathtub. Combined with the high temperature test method, consumers would have a way to directly compare the performance of water heaters of different sizes that can meet the same user needs.

In response to DOE's request for comment regarding its proposed equations and approach to calculate effective storage volume, Rheem agreed that DOE's derivation from an energy balance was appropriate for calculating a scaling factor. (Rheem, No. 47 at p. 7) NEEA commented that that the

proposed method appears to contain an error in the calculation of the dimensionless volume scaling factor (k_v) by using 67.5 °F, the standard test condition ambient air temperature, instead of 58 °F, the standard test condition water inlet temperature. Otherwise, NEEA indicated support of DOE's proposed method for calculating the effective storage volume metric. (NEEA, No. 56 at p. 3)

DOE's volume scaling factor is derived by comparing the thermal energy stored by the water heater when the water is heated to 125 °F to the thermal energy stored at its maximum tank temperature. In response to NEEA's comment, DOE notes that the method to calculate the dimensionless volume scaling factor k_v uses ambient air temperature because as the water in the storage tank cools, heat is lost to the surrounding air. Thus, the water approaches the temperature of the surrounding air, not the 58 °F inlet water temperature. Therefore, DOE has maintained this calculation method as originally proposed.

Rheem suggested that an effective volume scaled to 125 °F is not useful for customers because a typical bath temperature is around 100 °F. (Rheem, No. 47 at p. 7) In response, DOE notes that the effective storage volume calculation is to show how much additional thermal energy is stored in the tank compared to a water heater which is not raising the internal tank temperature beyond the delivery temperature. Because 125 °F is the delivery setpoint temperature used in the appendix E test procedure as being representative of typical water heater setpoint temperatures, DOE has concluded that it is appropriate for the tank temperature has to be compared to 125 °F.

The CA IOUs supported DOE's proposed effective storage volume metric as being more representative of a storage water heater's hot water delivery capacity than rated storage volume. However, the CA IOUs asserted that effective storage volume does not account for differences in recovery rate between water heaters, a factor which also affects hot water delivery capacity and specifically FHR. The CA IOUs pointed out that large discrepancies in FHR exist within a given rated storage volume for both gas and electric storage water heaters. Therefore, the CA IOUs suggested DOE should revise its proposed algorithm for the effective storage volume to produce a metric incorporating the volume and temperature of the stored water and the water heater recovery rate. (CA IOUs, No. 52 at pp. 2–4)

In response, effective storage volume is intended to measure the maximum thermal energy a water heater can store and to indicate the amount of hot water that is immediately available. Effective storage volume is not intended to measure how fast the unit is able to heat water. This is in contrast with FHR, which accounts for the water heater's recovery rate as previously described. Accounting for water heater recovery rate in the effective storage volume calculation would make the effective storage volume metric duplicative of the existing FHR metric; DOE reiterates that effective storage volume will not replace FHR, which will remain a part of the test procedure. A.O. Smith stated that the effective storage volume metric may become obsolete if DOE's proposed energy conservation standards effectively limit the availability of non-demand response water heaters with user-selectable high heat modes. (A.O. Smith, No. 51 at p. 7) In response to A.O. Smith's comment, DOE notes that the scope of this comment falls within that of the energy conservation standards rulemaking, so it will be properly considered in the concurrent standards rulemaking for consumer water heaters. Additionally, DOE would again mention that certification and representations of effective storage volume will not be required as a result of this final rule, but instead may be required at the time of any energy conservation standards that specifically address which water heaters may be required to carry out high temperature testing.

Finally, when proposing the calculation of estimated mean tank temperature in the July 2022 SNOPR, DOE inadvertently omitted the calculation of annual electrical energy consumption from the test procedure. DOE has once again included this calculation as originally proposed in the January 2022 NOPR at section 6.3.10 of appendix E.

b. Circulating Water Heaters

As discussed in section III.D.4 of this document, DOE is amending the test procedure to require that circulating water heaters must be tested with a separate storage tank. Specifically, gas-fired and oil-fired circulating water heaters and electric resistance circulating water heaters must be tested with an UFHWST, and heat pump-type circulating water heaters must be tested with an electric storage water heater.

For circulating water heaters, effective storage volume calculations will be carried out in a slightly different manner than for storage water heaters. The methodology established in this

final rule takes into consideration the concerns raised by stakeholders and discussed in section III.D.4 of this document. In summary, while commenters expressed that it would be beneficial to be able to use a range of UFHWST volumes for testing non-heat-pump-type circulating water heaters, commenters were also concerned that the results of testing may not be reproducible without certifying the specific model of UFHWST to be used. Regarding the volume, DOE understands that circulating water heater designs may be optimized to operate with specific storage volumes; thus, in this final rule, DOE is allowing a range of volumes to be used. However, manufacturers may represent the volume of the UFHWST in terms of the effective storage volume of the circulating water heater as follows.

Because circulating water heaters are to be tested with a separate storage tank, they operate, as a system, in a similar manner to storage-type water heaters. Although the volume stored by the circulating water heater itself may be small, these water heaters require a separate volume of water to operate properly. Therefore, DOE has determined that it is appropriate for the effective storage volume calculation for circulating water heaters to account for the separate storage tank, as the volume of the stored water is representative of the effective volume that would be available for such a water heater in the field, since it is necessary to install a circulating water heater with a storage tank or other stored volume of water. The procedure for calculating effective storage volume of separate storage tanks paired with circulating water heaters is outlined in section 6.3.1.1 of appendix E. This procedure will prescribe the value of the measured storage volume of the separate storage tank to be the effective storage volume of the circulating water heater, and the measured storage volume of the separate storage tank shall be determined in accordance with section 5.2.1 of the amended appendix E (Determination of Storage Tank Volume). This allows the same method of volume measurement to be applied to UFHWSTs and separate electric resistance storage tanks. DOE has determined that this approach allows for manufacturers to have the flexibility to use the appropriate size of UFHWST for the circulating water heater while still ensuring that testing can be done in a reproducible manner.

In a separate rulemaking pertaining to certification requirements for consumer water heaters and residential-duty commercial water heaters, DOE will address any potential amendments

which would need to be made in order to certify the effective storage volume of a product. DOE would consider establishing product-specific enforcement provisions for circulating water heaters at such a time when energy conservation standards for these products are evaluated.

G. Untested Provisions (Alternative Efficiency Determination Methods)

At 10 CFR 429.70, DOE specifies alternative methods for determining energy efficiency and energy use for certain covered products and equipment, including consumer water heaters.⁷⁶ In general, these provisions allow a manufacturer to determine the energy efficiency or energy use of a basic model using an alternative efficiency determination method (AEDM) in lieu of actually testing the basic model. Specific to each product or equipment type covered by these AEDM provisions, DOE defines the criteria for using an AEDM and, for some products and equipment, procedures to be used to validate an AEDM and to perform verification testing on units certified using an AEDM.

The provisions at 10 CFR 429.70(g) provide alternative methods for determining ratings for “untested” basic models of residential water heaters and residential-duty commercial water heaters. For models of water heaters that differ only in fuel type or power input, these provisions allow manufacturers to establish ratings for untested basic models based on the ratings of tested basic models if certain prescribed requirements are met. (Simulations or other modeling predictions or ratings of UEF, volume, first-hour rating, or maximum gallons per minute are not permitted (10 CFR 429.70(g)).)

Specifically, for gas water heaters, the provisions at 10 CFR 429.70(g)(1) specify that for untested basic models of gas-fired water heaters that differ from tested basic models only in whether the basic models use natural gas or propane gas, the represented value of UEF, FHR, and maximum gallons per minute for an untested basic model can be the same as those for a tested basic model, as long as the input ratings of the tested and untested basic models are within ± 10 percent.

For electric storage water heaters, the provisions at 10 CFR 429.70(g)(2) specify rating an untested basic model using the FHR and the UEF obtained from a tested basic model as a basis for ratings of basic models with other input

ratings, provided that certain conditions are met: (1) each heating element of the untested basic model is rated at or above the input rating for the corresponding heating element of the tested basic model; and (2) for an untested basic model having any heating element with an input rating that is lower than that of the corresponding heating element in the tested basic model, the FHR for the untested basic model must result in the same draw pattern specified in Table I of appendix E for the simulated-use test as was applied to the tested basic model.⁷⁷ 10 CFR 429.70(g)(2)(i)–(ii).

In commenting on this topic in response to the January 2022 NOPR, Rheem suggested expanding the AEDM provisions for consumer water heaters to address circulating water heaters. Specifically, Rheem identified three possible AEDM approaches: (1) test the thermal efficiency or COP using the commercial water heater test procedure and use the result to calculate an estimated UEF for various storage capacities; (2) open the commercial HVAC AEDM provisions at 10 CFR 429.70(c) to circulating consumer water heaters; or (3) add provisions similar to the current electric storage water heater AEDM, where a change in draw pattern would necessitate a new test. (Rheem, No. 31 at pp. 3–4)

Further, DOE notes that although manufacturers of consumer water heaters are not authorized to use an AEDM under 10 CFR 429.70(c) to determine ratings for consumer water heaters, as discussed, manufacturers may determine UEF for certain models using the methods specified under 10 CFR 429.70(g). These models include: (1) gas-fired basic models differing only in whether the basic models use natural gas or propane and with an input rating within 10 percent and (2) electric storage water heater basic models differing only in heating element input rating (in addition, for untested basic models with a heating element with an input rating that is lower than the input rating of the corresponding element in the tested basic model, the FHR for the untested basic model must also result in the same draw pattern as was applied to the tested basic model). These

⁷⁷ To establish whether this condition is met, the provisions at 10 CFR 429.70(g)(2)(ii) specify determining the FHR for the tested and the untested basic models in accordance with the procedure described in section 5.3.3 of 10 CFR part 430, subpart B, appendix E, and then comparing the appropriate draw pattern specified in Table I of appendix E for the FHR of the tested basic model with that for the untested basic model. If this condition is not met, then the untested basic model must be tested and the appropriate sampling provisions applied to determine its UEF in accordance with appendix E.

provisions already provide manufacturers with some measure of an alternative method of rating consumer water heaters without testing every model, and this alternative method reduces manufacturer test burden. Further, DOE explained in a 2013 final rule pertaining to AEDMs that the AEDM provisions extend to those products or equipment which have “expensive or highly-customized basic models.” 78 FR 79579, 79580 (Dec. 31, 2013). The current AEDM provisions for commercial HVAC equipment (including commercial water heaters, for example) were in part the result of a negotiated rulemaking effort by the Appliance Standards and Rulemaking Federal Advisory Committee (ASRAC) in 2013. *Id.* Consumer water heaters were not considered at the time.⁷⁸ *Id.* In this rulemaking, DOE did not receive comments indicating that these conditions would apply for consumer water heaters or residential-duty commercial water heaters, and, hence, DOE has determined that modeling-based AEDMs are not required at this time. Additionally, the test method adopted in this final rule has been determined to be representative of energy use over an average use cycle without being unduly burdensome.

Given these factors, DOE is not considering further expansion of the AEDM provisions for water heaters within the scope of this test procedure, aside from applying the untested model provisions to electric instantaneous water heaters, as discussed in section III.G.2 of this document. The following sections discuss representations of the FHR value of certain untested models and the extension of the alternative rating method to electric instantaneous-type water heaters.

1. Representations of First-Hour Ratings for Untested Basic Models

The provisions at 10 CFR 429.70(g) allow for an untested electric storage water heater basic model with element wattages less than a tested basic model to use the FHR of the tested basic model, provided that the untested basic model’s FHR is in the same draw pattern as the tested basic model. For an untested basic model with an element wattage that is lower than the tested basic model’s, the tested FHR of the untested basic model will generally be less than the FHR of the tested basic model. In such cases, using the tested basic model’s FHR to represent the untested model’s FHR may not be as

⁷⁸ Working group meeting transcripts can be found at www.regulations.gov under Docket No. EERE–2013–BT–NOC–0023.

⁷⁶ Section 429.71 uses the term “residential,” which is synonymous with the use of the term “consumer” in this document.

representative as using the FHR value directly determined from the untested model (the FHR of the untested basic model is determined pursuant to the procedures in appendix E specifically for the purpose of allowing use of the tested basic model's UEF rating). Instead, using the untested basic model's measured FHR for representation purposes, rather than the tested model's FHR (as currently required), could increase the representativeness of the certified FHR, while potentially not increasing burden on the manufacturer.

The January 2022 NOPR requested comment on the potential to revise the existing provisions at 10 CFR 429.70(g)(2)(ii) for electric storage water heaters with element wattages less than the tested basic model to require that the represented FHR of the untested model be the untested basic model's FHR as determined according to the procedures at appendix E. Specifically, DOE sought information on whether manufacturers collect sufficient data to establish a rated value of FHR based on FHR testing for untested basic models, subject to the sampling plan requirements at 10 CFR 429.17 (*i.e.*, whether manufacturers currently measure the FHR of at least two units of an untested basic model to ensure it is in the same draw pattern bin as the tested model). 87 FR 1554, 1587–1588 (Jan. 11, 2022).

In commenting on this issue, ASAP, ACEEE, and NCLC supported revising the untested provisions for storage water heaters so that the first-hour ratings for untested models are used for ratings. Likewise, ASAP, ACEEE, and NCLC also supported requiring that the represented value of max GPM for untested electric instantaneous water heaters be the actual value determined for the untested model. (ASAP, ACEEE, and NCLC, No. 34 at p. 3)

BWC offered a different view, commenting that the current AEDM provisions yield accurate results for untested electric storage water heaters with element wattages less than the tested basic models. The company stated that changing these provisions would result in significant burden for manufacturers without producing significantly different results. BWC also urged DOE to not apply the more stringent AEDM requirements for electric storage water heaters to electric instantaneous water heaters. (BWC, No. 33 at pp. 10–11)

Similarly, AHRI raised concerns about the increased burden associated with the proposed additional requirements for alternate electric storage water heater input ratings. (AHRI, No. 40 at p. 3)

AHRI indicated that, because the sampling plan provisions at 10 CFR 429.17 are not currently required when certifying untested models, manufacturers would have to retest and recertify untested models if DOE were to adopt such requirements. (AHRI, No. 40 at pp. 5–6) A.O. Smith requested additional clarity on exactly which untested models would need to be tested to confirm FHR ratings under the proposed untested provisions. (A.O. Smith, Jan. 27, 2022 Public Meeting Transcript, No. 27 at pp. 48–49) A.O. Smith claimed that the established practice has been to evaluate untested electric storage water heater tank inputs to confirm that these models would perform in the same draw pattern as the tested model. A.O. Smith also stated that certifying data for untested models would be an extra testing burden for manufacturers which have relied on the procedures pursuant to alternative methods for determining energy efficiency and energy use to establish the ratings, and, therefore, the commenter recommended against the Department changing the relevant data collection methodology. (A.O. Smith, No. 37 at pp. 4–5)

After consideration of the comments and the additional burden that an amendment relating to the FHR representations for certain untested water heaters would impose, DOE has decided not to amend these provisions at this time. However, DOE reiterates that, per the current AEDM requirements, manufacturers are required to test the FHR of an untested model prior to making a determination as to whether or not the untested model will fall under the same draw pattern as the tested model. This determination should not be made on the basis of input rates alone. Manufacturers should consult 10 CFR 429.70(g), which states, “simulations or other modeling predictions for ratings of the uniform energy factor, volume, first-hour rating, or maximum gallons per minute (GPM) are not permitted.” Furthermore, as a clarification of the existing reporting requirements, manufacturers using the untested provisions to certify certain water heater models to DOE must identify these models as being tested to an AEDM (*see* 10 CFR 429.17(b)(1), which references 10 CFR 429.12).

2. Alternative Rating Method for Electric Instantaneous Water Heaters

In the January 2022 NOPR, in response to earlier stakeholder comments, DOE proposed to expand the untested provisions (described in detail in section III.G.1 of this document) so as to apply similar provisions to electric

instantaneous water heaters. The proposed expansion would allow electric instantaneous water heaters and electric storage water heaters to have similar AEDM requirements. 87 FR 1554, 1588 (Jan. 11, 2022).

As discussed in further detail in the January 2022 NOPR, because electric instantaneous water heaters exhibit the same trends in performance that justify the use of an alternative rating determination method for electric storage water heaters, DOE tentatively determined that extending the use of the untested provisions to electric instantaneous water heaters in 10 CFR 429.70(g) would maintain a representative rating of these products' energy efficiency, while reducing manufacturer burden. Therefore, DOE proposed to permit use of the untested provisions for electric instantaneous water heaters through newly proposed provisions at 10 CFR 429.70(g)(3). Specifically, the January 2022 NOPR proposed that the criteria that currently apply to electric storage water heaters at 10 CFR 429.70(g)(2) would apply to electric instantaneous type water heaters at 10 CFR 429.70(g)(3), with the exceptions that: (1) The criteria for electric instantaneous water heaters would reference the maximum GPM rather than the FHR, as FHR applies only to storage water heaters; and (2) the criteria for electric instantaneous water heaters would reference the “input rate” rather than the “heating element” or “input rating for the corresponding heating element.” 87 FR 1554, 1588 (Jan. 11, 2022).

On this topic, AHRI and A.O. Smith expressed support for the inclusion of electric instantaneous water heaters in the untested provisions. (AHRI, No. 40 at pp. 5–6; A.O. Smith, No. 37 at p. 2) Based upon its previous reasoning and after considering the relevant comments, DOE is adopting the untested provisions for electric instantaneous water heaters as proposed in the January 2022 NOPR, with only a minor modification.

Section III.H.1 of this document discusses terminology used with respect to storage vs. instantaneous and flow-activated vs. non-flow-activated water heaters. Specifically, DOE has determined that not all instantaneous water heaters are flow-activated, and also that storage water heaters do not necessarily have to be non-flow-activated, either. As such, in this final rule, DOE is amending the language in all of the untested provisions (those which currently exist and those which are being newly established) such that the delivery capacity metric may be either FHR or Max GPM. This correction

will harmonize the requirements at 10 CFR 429.70(g) with the test procedure, which specifies that the Max GPM metric is for flow-activated water heaters, and the FHR metric is for all others, regardless of the water heater's classification as storage-type or instantaneous-type (see section 5.3 of appendix E).

H. Corrections and Clarifications

DOE is adopting certain corrections and clarifications to the appendix E test procedure that are intended to improve the repeatability and reproducibility of the test procedure. These changes are described in more detail in the subsections that follow.

1. Flow-Activated Terminology

In sections 5.3.3.1 and 5.3.3.2 of appendix E, which describe general requirements and draw initiation criteria, respectively, for the FHR test, the term “storage-type water heaters” is used. However, the FHR test applies to all water heaters that are not flow-activated, which includes non-flow-activated instantaneous water heaters. In this rulemaking, DOE sought feedback on updating the phrase “storage-type water heaters” in section 5.3.3 to “non-flow-activated water heaters.” 85 FR 21104, 21112 (April 16, 2020). Multiple stakeholders provided comments on the use of “flow-activated” and “non-flow-activated” in response to the April 2020 RFI and the January 2022 NOPR.

Initially, commenters such as AHRI and some manufacturers stated that there is no need to change the phrase “storage-type water heaters” in section 5.3.3 of appendix E. However, when DOE submitted a comment to the ASHRAE 118.2 drafting committee suggesting the change from “storage-type” to “non-flow-activated” in the corresponding sections of ASHRAE 118.2, this change was accepted by the committee and used in ASHRAE 118.2–2022. Thus, DOE proposed to update the terminology in the January 2022 NOPR in an effort to align terminology with that recognized by industry. 87 FR 1554, 1576 (Jan. 11, 2022).

Specifically, section 7.3.3.1 of ASHRAE 118.2–2022 uses the term “non-flow-activated” water heaters, whereas section 5.3.3.1 of the current appendix E test procedure uses the term “storage-type” water heaters. Yet section 7.3.3.2 of ASHRAE 118.2–2022 still uses the “storage-type” term that is present in section 5.3.3.2 of appendix E. By contrast, DOE's proposal, as delineated in the January 2022 NOPR, would effectively ensure that language related to the FHR test did not

inadvertently narrow the scope of that test to only storage-type water heaters whenever the term “storage-type” was used in this context.

On this topic, Rheem supported the proposed amendments to the language throughout appendix E to use “non-flow-activated” and “flow-activated,” and to refer to water heaters with or without storage volumes greater than 2 gallons as such. Rheem stated that these changes eliminate the storage or instantaneous type language except where helpful to navigate the appendix. (Rheem, No. 31 at p. 2)

Many commenters expressed confusion regarding DOE's proposed changes in terminology in appendix E, however. At the public meeting webinar for the January 2022 NOPR, AHRI requested further explanation of the intent behind the proposed terminology update changing “storage-type” and “instantaneous-type” to “non-flow-activated” and “flow-activated,” especially since the proposed terms are not used in EPCA. AHRI requested that DOE clarify whether or not the terminology change would have any impact on testing. (AHRI, Jan. 27, 2022 Public Meeting Transcript, No. 27 at pp. 41–42) In its written comments, AHRI stated that replacing the “instantaneous-type” and “storage-type” terminology with “flow-activated” and “non-flow-activated” may cause confusion for the test methods relevant to water heaters larger than 20 gallons in rated storage volume. AHRI suggested that DOE should consider adding steps to the test procedure to determine: (1) if a unit is “storage-type” or “instantaneous-type” and (2) if a unit is “flow-activated” or “non-flow-activated.” (AHRI, No. 40 at p. 4) BWC did not support a change from the terms “storage-type” and “instantaneous-type” to “non-flow-activated” and “flow-activated” for water heaters above 20 gallons, stating that it would create confusion for manufacturers and testing laboratories. (BWC, No. 33 at p. 6)

AET commented that a flow-activated electric instantaneous water heater will need to be able to heat its stored volume of water to the 67 °F temperature rise in appendix E in no more than about 30 seconds based on a calculation of recovery efficiency and flow rate. (AET, No. 29 at pp. 3–5) However, DOE notes that this calculation is only possible because the recovery efficiency of an electric resistance water heater is defined as 98 percent in the appendix E test procedure; the time criterion would vary for other types of water heaters.

Furthermore, AET commented that DOE should be careful in its use of the

term “instantaneous” water heater to ensure the test procedure for these products applies to all products which have more than 4,000 Btu/h of input per gallon of storage, adding that there are instantaneous water heaters have several gallons of storage capacity or are thermostatically-activated (which should be tested under a non-flow-activated test method). The commenter stressed that water heaters should be tested per the flow-activated or non-flow-activated test method based on whether or not they are indeed flow-activated, and not whether they are instantaneous-type or storage-type. AET commented that a thermostatically-activated unit does not necessarily mean that stored water is kept fully heated, but rather that the rate of change of temperature of stored water can be used to indicate whether a flow is occurring, and, therefore, the distinction between flow-activation and non-flow-activation (*i.e.*, thermostatic activation) may be difficult to make for water heaters with very small volumes. AET claimed that hybrid instantaneous water heaters activated by both flow and water temperature are under development, and such appliances should be addressed in the test procedure. AET also noted that the largest possible instantaneous-type gas-fired unit may have up to 50 gallons of storage volume per the codified definitions, and the largest possible instantaneous-type oil-fired unit may have up to 52.5 gallons of storage volume. Additionally, AET provided detailed comments indicating that not all instantaneous water heaters are flow-activated within the scope of the standards of consumer water heaters, so DOE should not use the terms interchangeably. (AET, No. 29 at pp. 2–6)

To clarify the intent of the January 2022 NOPR's proposal: DOE agrees with AET that the distinction between storage-type water heaters and instantaneous-type water heaters is different from the distinction between flow-activated water heaters and water heaters with other activation schemes. Comments from manufacturers seem to indicate that there could be a misconception that “instantaneous-type water heater” and “flow-activated water heater” are interchangeable, because these comments opposed DOE's correction to remove the “storage-type” term from the description of the FHR test and replace it with the “non-flow-activated” term; however, these terms are *not* interchangeable. When a water heater is referred to as “storage-type” or “instantaneous-type,” those terms specifically refer to the ratio between

the storage volume and the input rate. These terms are defined in EPCA (*see* 42 U.S.C. 6291(27)(A) and (B)) and at 10 CFR 430.2. For example, DOE's energy conservation standards at 10 CFR 430.32(d) distinguish between storage-type and instantaneous-type water heaters. Section 1.6 of appendix E defines "flow-activated" as an operational scheme in which a water heater initiates and terminates heating based on sensing flow in order to determine which method of testing is most appropriate for the water heater's operational scheme. Therefore, whether a water heater is storage-type or instantaneous-type has no bearing on whether it is determined to be "flow-activated." There can be flow-activated storage water heaters or even non-flow-activated instantaneous water heaters. In fact, circulating water heaters are defined as non-flow-activated instantaneous water heaters (*see* section III.A.4.a of this final rule).

Section 5.3.1 of appendix E states, "For flow-activated water heaters, conduct the maximum GPM test, as described in section 5.3.2, *Maximum GPM Rating Test for Flow-Activated Water Heaters*, of this appendix. For all other water heaters, conduct the first-hour rating test as described in section 5.3.3 of this appendix." In this final rule, the Department is maintaining this requirement in the revised appendix E test procedure.

With respect to comments related to how to determine whether a water heater is flow activated, DOE has concluded that the definition of "flow-activated" in proposed section 1.6 of appendix E is sufficient for manufacturers and testing laboratories to determine whether a product meets that definition. Specifically, if a water heater initiates or terminates heating as a result of sensing flow—regardless of what type of sensor is used to determine whether a flow is occurring—then the water heater is flow-activated. If a water heater has two activation schemes, one of which is based on sensing flow (*e.g.*, heating can also be initiated due to the tank temperature crossing below a certain thermostat limit), then it still meets the description of a flow-activated water heater, and, therefore, must be tested as such. This is a clarification of the current test procedure and not an amendment, and, thus, DOE is maintaining the language in the definition of "flow-activated" in appendix E (which will now appear at section 1.7).

DOE understands that the term "non-flow-activated," which was used in the January 2022 NOPR's proposal, could be a source of confusion, because, as AET

states, there are products which are dually activated. Hence, in this final rule, DOE is not introducing this term into the appendix E test procedure. Instead, DOE is striking out the references to storage-type water heaters in provisions related to water heaters which require the FHR test and striking out the reference to instantaneous-type water heaters in provisions related to water heaters which require the Max GPM test. Because section 5.3.1 already instructs which test is required, these instances of the terms "storage-type" and "instantaneous-type" are inaccurate and extraneous. DOE has determined that these corrections and clarifications do not change the way in which the appendix E test procedure is conducted.

2. Second Identical 24-Hour Simulated-Use Test

For water heaters that are not flow-activated, the water heaters test procedure in section 5.2.2.2 of the currently applicable appendix E includes directions for setting the temperature controllers such that the test method is repeatable and reproducible.

A.O. Smith requested DOE to clarify that, when testing water heaters larger than or equal to 20 gallons, the second identical simulated-use test is not a requirement of the procedure but only a means by which to validate the stability of the setting, if it is deemed necessary to perform. (A.O. Smith, No. 37 at p. 7)

In response, the Department notes that there is no requirement for a second identical 24-hour simulated-use test in appendix E. Sections 5.2.2.2.1.1 and 5.2.2.2.1.2 of the currently applicable test procedure states that once the proper temperature control setting is achieved, the setting must remain fixed for the duration of the first-hour rating test and the simulated-use test such that a second identical simulated-use test run immediately following the one specified in section 5.4 would result in average delivered water temperatures that are within the bounds specified in section 2.4 of this appendix. This language was included to explain the intent of the temperature control. However, for units which have an integrated mixing valve or that are intended for use with a mixing valve, the language describing the second identical 24-hour simulated-use test may be misleading, as there may be individual draws where the outlet temperature is outside the bounds specified in section 2.4 of appendix E. As a result, the Department is amending the language to remove reference to a second 24-hour simulated-use test. The procedure to ensure the stability of the

temperature control as described in sections 5.2.2.2.1.1 and 5.2.2.2.1.2 remains unchanged.

3. Connected Products

Section 5.1 of appendix E currently specifies the operational mode selection for water heaters but does not explicitly address "smart" or "connected" modes of operation. For water heaters that allow for multiple user-selected operational modes, all procedures specified in appendix E must be carried out with the water heater in the same operational mode (*i.e.*, only one mode). This operational mode must be the default mode (or similarly named, suggested mode for normal operation) as defined by the manufacturer in its product literature for giving selection guidance to the consumer.

On September 17, 2018, DOE published an RFI seeking information on the emerging smart technology appliance and equipment market. 83 FR 46886 (September 2018 RFI). In the September 2018 RFI, DOE sought information to better understand market trends and issues in the emerging market for appliances and commercial equipment that incorporate smart technology. *Id.* at 83 FR 46887. DOE's intent in issuing the September 2018 RFI was to ensure that DOE did not inadvertently impede such innovation when fulfilling its statutory obligations to set efficiency standards for covered products and equipment. *Id.* In the April 2020 RFI, DOE sought comment on the same issues presented in the September 2018 RFI as they may be specifically applicable to consumer water heaters. 85 FR 21104, 21114 (April 16, 2020).

Responding to the April 2020 RFI, commenters urged DOE to update the test procedure to better capture the performance differences between traditional and connected products, provided some recommended definitions delineating the types of connected products, and suggested that DOE adopt additional and/or optional performance metrics related to grid connectivity. These comments are discussed in detail in the January 2022 NOPR. 87 FR 1554, 1585 (Jan. 11, 2022). In the January 2022 NOPR, DOE proposed to explicitly state that any connection to an external network or control would be disconnected during testing. DOE proposed this given that there were insufficient data on consumer usage of connected features for the Department to develop a representative test configuration for assessing the energy consumption of connected functionality for water

heaters. 87 FR 1554, 1585–1586 (Jan. 11, 2022).

On this topic, BWC agreed with DOE's tentative determinations and clarifications regarding the testing of connected water heaters. (BWC, No. 33 at p. 9) NYSERDA recommended that DOE ensure the test procedure supports grid-enabled water heaters specifically, as well as connected water heaters generally. To this point, NYSERDA recommended that DOE should specify how manufacturers can demonstrate their products are “connected” and include this as an item for reporting to the agency. NYSERDA encouraged DOE to consider the power usage for connectedness, as this would be informative for utilities planning for decarbonization. Additionally, NYSERDA stated that including the power usage for connected functions would encourage the load to be minimal and better inform consumers regarding anticipated operating costs. (NYSERDA, No. 32 at pp. 2–3)

In response, while DOE acknowledges the potential benefits that could be provided by connected capability, such as providing energy saving benefits to consumers and enabling peak load shifting on the grid, the Department has concluded that requiring measurement and reporting of the energy consumed by connected features at this time may prematurely hinder the development and incorporation of such features in water heaters. As such, DOE is clarifying that connected features on water heaters should remain on but disconnected from any external network or control for the duration of the appendix E test. This approach will allow some baseline energy consumption to be accounted for without imposing any specific network connection test requirements.

4. Heating Value of Gas

In this rulemaking, DOE considered the need for a clarification regarding the correction of the heating value to a standard temperature and pressure. Section 3.7 of appendix E states that the heating values of natural gas and propane must be corrected from those reported at standard temperature and pressure conditions to provide the heating value at the temperature and pressure measured at the fuel meter, but does not specify standard temperature and pressure conditions. Without a specified standard temperature and pressure, the heating values used in calculations may not be consistent from laboratory to laboratory.

As discussed in the January 2022 NOPR, there are several sources which do specify the standard temperature and

pressure conditions for natural gas calculations. 87 FR 1554, 1578 (Jan. 11, 2022). For example, AHRI maintains an Operations Manual for Residential Water Heater Certification Program (AHRI Operations Manual), which includes an equation that corrects the measured heating value, when using a dry gas and a wet test meter, to the heating value at the standard temperature and pressure of 60 °F (15.6 °C) and 30 inches of mercury column (101.6 kPa), respectively. Annex B of the March 2019 ASHRAE Draft 118.2 also provides a method for correcting the heating value from measured to standard conditions, which allows for the use of either dry or saturated gas and either a dry or wet test meter—and this calculation was finalized in ASHRAE 118.2–2022 with an example provided for 60 °F (15.6 °C) and 30 inches of mercury column (101.6 kPa). Lastly, sections 2.4.1 and 3.1.1 of appendix O to subpart B of 10 CFR part 430 (Uniform Test Method for Measuring the Energy Consumption of Vented Home Heating Equipment) correct the input rate to the standard conditions of 60 °F (15.6 °C) and 30 inches of mercury column (101.6 kPa). Therefore, to align with the AHRI Operations Manual and the current practice in other appendices within part 430 of the CFR, DOE proposed in the January 2022 NOPR to establish the standard temperature and pressure conditions for gas measurements as 60 °F (15.6 °C) and 30 inches of mercury column (101.6 kPa), respectively. Further, DOE proposed to adopt the method used in Annex B of a finalized ASHRAE 118.2–2022 to correct the heating value of gas to standard conditions. 87 FR 1554, 1578 (Jan. 11, 2022).

DOE did not receive comments from stakeholders regarding this proposal. Accordingly, DOE is adopting these proposals in this final rule for the reasons previously discussed.

I. Effective and Compliance Dates

The effective date for the adopted test procedure amendments will be 30 days after publication of this final rule in the **Federal Register**.

As to the compliance date, EPCA prescribes that all representations of energy efficiency and energy use for consumer products (including consumer water heaters), including those made on marketing materials and product labels, must be made in accordance with an amended test procedure, beginning 180 days after publication of the final rule in the **Federal Register**. (42 U.S.C. 6293(c)(2)) For residential-duty commercial water heaters, this

requirement is beginning 360 days after publication of the final rule in the **Federal Register**. (42 U.S.C. 6314(d)(1)) For consumer products, EPCA provides an allowance for individual manufacturers to petition DOE for an extension of the 180-day period if the manufacturer may experience undue hardship in meeting the deadline. (42 U.S.C. 6293(c)(3)) To receive such an extension, petitions must be filed with DOE no later than 60 days before the end of the 180-day period and must detail how the manufacturer will experience undue hardship. (*Id.*)

With the exception of two test method provisions (*i.e.*, high temperature testing and separate storage tank testing), compliance with the modified test procedure adopted in this final rule is required for consumer water heaters beginning 180 days after the date of publication of this final rule in the **Federal Register**. Similarly, with the exception of the separate storage tank testing requirement, compliance with the modified test procedure is required for residential-duty commercial water heaters beginning 360 days after the date of publication of this final rule in the **Federal Register**.

Beginning on the effective date of this final rule, the use of the high temperature test method (section 5.1.2 of the amended appendix E test procedure) will be allowed for voluntary additional representations until the compliance date of amended energy conservation standards for consumer water heaters that address high temperature operation, should such standards be adopted. Until such a time, the normal temperature test method (section 5.1.1 of the amended appendix E test procedure) is required as the basis for ratings used to determine compliance with energy conservation standards. During this voluntary usage period, manufacturers who choose to publish two sets of ratings must clearly indicate which values correspond to the high temperature test method. In the standards rulemaking, DOE plans to clarify which type(s) of water heaters would be required to utilize the high temperature test method when determining compliance with potential amended standards.

The use of the separate storage tank test method for circulating water heaters (section 4.10 of the amended appendix E test procedure) will be allowed for voluntary representations and compliance with standards beginning on the effective date of this final rule. This test method will become mandatory when compliance with amended energy conservation standards for consumer water heaters and

residential-duty commercial water heaters is required, should such standards addressing circulating water heaters be adopted.

Upon the compliance date of test procedure provisions in this final rule, any waivers that had been previously issued and are in effect that pertain to issues addressed by such provisions are terminated. 10 CFR 430.27(h)(3) and 431.401(h)(3). Recipients of any such waivers are required to test the products subject to the waiver according to the amended test procedure as of the compliance date of the amended test procedure. The amendments adopted in this document pertain to issues addressed by a waiver granted to Bradford White Corporation (Case No. 2019-006). See 85 FR 5648 (Jan. 31, 2020). On January 31, 2020, DOE published a Notice of Decision and Order in the **Federal Register** granting Bradford White Corporation a waiver for a specified basic model that experiences the first cut-out of the 24-hour simulated-use test during a draw. 85 FR 5648. The Decision and Order requires Bradford White Corporation to use an alternate test procedure that DOE determined more accurately calculates the recovery efficiency when the first cut-out occurs during a draw. *Id.* at 85 FR 5651. As described in section III.B.2.b of this document, DOE is adopting the alternate test procedure prescribed in the Decision and Order granted to Bradford White Corporation into the test procedure at appendix E.

J. Test Procedure Costs

EPCA requires that test procedures proposed by DOE not be unduly burdensome to conduct. (42 U.S.C. 6293(b)(3)) The following sections discuss DOE's evaluation of estimated costs associated with the proposed amendments for consumer water heaters and residential-duty commercial water heaters.

1. Separate Storage Tanks

In the January 2022 NOPR, DOE tentatively concluded that the cost of running the test procedure using an 80-gallon unfired hot water storage tank should be the same as testing a water heater with an integrated tank with a comparable storage volume. The Department estimated that testing a fossil fuel-fired or electric storage water heater would cost approximately \$3,000 and that testing an electric storage water heater which uses heat pump technology would cost approximately \$4,500. In addition to the testing cost, the manufacturer or third-party testing facility would incur a one-time cost to purchase an unfired hot water storage

tank which are commercially available for approximately \$900. 87 FR 1554, 1589 (Jan. 11, 2022).

In the July 2022 SNOPR, DOE revised its proposal. DOE estimated that, for gas-fired circulating water heaters, these proposed changes could require a one-time purchase of an 80- to 120-gallon unfired hot water storage tank, which are readily commercially available for approximately \$2,000. For heat pump-only water heaters, the proposed changes could result in a one-time purchase of a 40-gallon (± 4 gallons) electric storage water heater readily available for approximately \$500. 87 FR 42270, 42283 (July 14, 2022).

DOE evaluated stakeholder feedback regarding this testing requirement and further revised its amended provision. This final rule adopts the following changes concerning the testing of circulating water heaters:

(1) Gas-fired circulating water heaters be tested using an unfired hot water storage tank with a storage volume between 80 and 120 gallons and an R-value exactly at the minimum R-value required at 10 CFR 431.110(a).

(2) Heat pump circulating water heaters be tested using a 40-gallon (± 5 gallons) electric storage water heater at the minimum UEF standard required at 10 CFR 430.32(d).

AHRI generally agreed with the estimated costs presented in the January 2022 NOPR, with the exception that \$900 may be an underestimate of the cost of purchasing an unfired hot water storage tank. (AHRI, No. 40 at p. 3) No further comments on test costs were received in response to the July 2022 SNOPR. Based upon its subsequent review in light of AHRI's comment, DOE notes that its estimate for the retail price of an unfired hot water storage tank has been raised from \$900 to \$2,000.

In response, DOE recognizes that these amendments will require manufacturers to make one-time purchases of the necessary storage tanks for each testing facility. DOE's research indicates that the tanks required for testing gas-fired circulating water heaters and heat pump circulating water heaters are commercially available at retail prices of \$2,000 and \$500, respectively, thereby reflecting third-party laboratory testing costs.

These amendments to appendix E regarding storage tank requirements will allow affected models to be certified for the first time. Manufacturers will not be able to rely on data generated under test procedures in effect prior to this final rule.

2. Method for Determining Internal Tank Temperature for Certain Water Heaters

This final rule amends section 5.4 of appendix E by the addition of section 5.4.2.2, which allows internal tank temperature to be estimated by removing water from the water heater for models with rated storage volumes greater than or equal to 2 gallons whose internal tank temperatures are unable to be measured using thermocouples.

DOE estimates that this testing method may extend test duration by up to 8 hours as part of the final standby period of the 24-hour simulated use test. This additional duration is estimated to increase testing costs by up to \$1,000 for affected fossil-fuel-fired and electric water heaters and \$1,500 for affected heat pump water heaters.

The addition of section 5.4.2.2 to appendix E will allow affected models to be certified for the first time. Because these water heaters could not previously be accurately tested, manufacturers will not be able to rely on data generated under test procedures in effect prior to this final rule.

3. High Temperature Testing

DOE recognizes that the amendment specifying the high temperature testing method would likely cause UEF ratings for any products that would become subject to this test method (*i.e.*, a subset of electric resistance storage water heaters) to decrease if they are currently certified using a default temperature setting. In order to limit potential retesting and recertification burden for manufacturers, any requirement to test certain products using the high temperature testing method will be established only once DOE completes its ongoing reviews of potential amended energy conservation standards for consumer water heaters, should such standards be adopted. The cost to test per this amended method would not be different from the cost to test per the method in the currently applicable appendix E test procedure (*i.e.*, testing an electric storage water heater would cost approximately \$3,000).

4. Additional Amendments

The remainder of the test procedure amendments adopted in this final rule will not impact test costs.

DOE is amending section 2.5 of appendix E, "Set Point Temperature," to allow low-temperature water heaters to deliver water at the maximum outlet temperature that they are capable of producing. This aligns with how these products are tested currently. Manufacturers already should have

requested a waiver for these products, as the current test procedure cannot be used as written to test low-temperature water heaters. As these products are currently tested and rated to the procedures which DOE is adopting, there should be no additional cost associated with this change.

DOE is also amending the existing test procedure for consumer and residential-duty commercial water heaters by modifying the flow rate requirements during the FHR test for water heaters with a rated storage volume less than 20 gallons. This change does not significantly affect the test results of the FHR test, and, thus, DOE expects that manufacturers may rely on existing test data where available. Further, storage-type water heaters (which comprise the majority of water heaters that need to be tested for an FHR rating) with less than 20 gallons of rated storage volume currently do not have energy conservation standards codified at 10 CFR 430.32(d) and are, therefore, not rated and certified to DOE.

Instantaneous-type water heaters that will require an FHR rating are expected to be circulating water heaters, and this final rule amends the appendix E test procedure in such a way that allows these products to be tested and rated for the first time (test costs for water heaters requiring separate storage tanks are discussed in section III.J.1 of this document). Therefore, the update to the FHR test method does not change the expected testing costs for products which have been tested per appendix E previously.

DOE is also amending the timing of the first measurement in each draw of the 24-hour simulated-use test and the test condition specifications and tolerances, including electric supply voltage tolerance, ambient temperature, ambient dry-bulb temperature, ambient relative humidity, standard temperature and pressure definition, gas supply pressure, and manifold pressure. These changes are intended to reduce retesting associated with having a single measurement out of tolerance, while maintaining the current representativeness of the test conditions and the stringency of the tolerances for the test conditions. DOE also has determined that the amendment to the flow rate tolerances for water heaters less than 2 gallons in rated storage volume would not alter the measured efficiency of consumer water heaters and residential-duty commercial water heaters, nor require retesting or recertification. In the absence of an explicit instruction for the flow rate tolerance applicable to water heaters with rated storage volume under 2

gallons, DOE expects that general industry best practice is to apply the flow rate tolerances being adopted for section 5.4.3 of appendix E for water heaters with rated storage volume less than 2 gallons (based on DOE's review of third-party laboratory test data), such that this proposal is expected to be consistent with current methodology.

Manufacturers will be able to rely on data generated under the current water heaters test procedure for the remainder of the amendments set forth in this final rule, so accordingly, such changes should result in no associated increase in costs.

IV. Procedural Issues and Regulatory Review

A. Review Under Executive Orders 12866, 13563, and 14094

Executive Order (E.O.) 12866, "Regulatory Planning and Review," 58 FR 51735 (Oct. 4, 1993), as supplemented and reaffirmed by E.O. 13563, "Improving Regulation and Regulatory Review," 76 FR 3821 (Jan. 21, 2011) and E.O. 14094, "Modernizing Regulatory Review," 88 FR 21879 (April 11, 2023), requires agencies, to the extent permitted by law, to: (1) propose or adopt a regulation only upon a reasoned determination that its benefits justify its costs (recognizing that some benefits and costs are difficult to quantify); (2) tailor regulations to impose the least burden on society, consistent with obtaining regulatory objectives, taking into account, among other things, and to the extent practicable, the costs of cumulative regulations; (3) select, in choosing among alternative regulatory approaches, those approaches that maximize net benefits (including potential economic, environmental, public health and safety, and other advantages; distributive impacts; and equity); (4) to the extent feasible, specify performance objectives, rather than specifying the behavior or manner of compliance that regulated entities must adopt; and (5) identify and assess available alternatives to direct regulation, including providing economic incentives to encourage the desired behavior, such as user fees or marketable permits, or providing information upon which choices can be made by the public. DOE emphasizes as well that E.O. 13563 requires agencies to use the best available techniques to quantify anticipated present and future benefits and costs as accurately as possible. In its guidance, the Office of Information and Regulatory Affairs (OIRA) in the Office of Management and Budget (OMB) has emphasized that such

techniques may include identifying changing future compliance costs that might result from technological innovation or anticipated behavioral changes. For the reasons stated in the preamble, this final regulatory action is consistent with these principles.

Section 6(a) of E.O. 12866 also requires agencies to submit "significant regulatory actions" to OIRA for review. OIRA has determined that this final regulatory action does not constitute a "significant regulatory action" under section 3(f) of E.O. 12866. Accordingly, this action was not submitted to OIRA for review under E.O. 12866.

B. Review Under the Regulatory Flexibility Act

The Regulatory Flexibility Act (5 U.S.C. 601 *et seq.*) requires preparation of a final regulatory flexibility analysis (FRFA) for any final rule where the agency was first required by law to publish a proposed rule for public comment, unless the agency certifies that the rule, if promulgated, will not have a significant economic impact on a substantial number of small entities. As required by Executive Order 13272, "Proper Consideration of Small Entities in Agency Rulemaking," 67 FR 53461 (August 16, 2002), DOE published procedures and policies on February 19, 2003 to ensure that the potential impacts of its rules on small entities are properly considered during the DOE rulemaking process. 68 FR 7990. DOE has made its procedures and policies available on the Office of the General Counsel's website: www.energy.gov/gc/office-general-counsel. DOE reviewed this final rule under the provisions of the Regulatory Flexibility Act and the procedures and policies published on February 19, 2003.

DOE is amending test procedures for consumer water heaters and residential-duty commercial water heaters. DOE is publishing this final rule in satisfaction of the 7-year-lookback review requirement specified in EPCA. (42 U.S.C. 6293(b)(1)(A); 6314(a)(1)) Further, amending test procedures for consumer and residential-duty commercial water heaters assists DOE in fulfilling its statutory deadline for amending energy conservation standards for products and equipment that achieve the maximum improvement in energy efficiency that is technologically feasible and economically justified. (42 U.S.C. 6295(o)(2)(A); 42 U.S.C. 6313(a)(6)) Additionally, amending test procedures for consumer and residential-duty commercial water heaters allows manufacturers to produce measurements of energy efficiency that

are representative of an average use cycle and uniform for all manufacturers.

On January 11, 2022, DOE published a test procedure NOPR (January 2022 NOPR) in the **Federal Register** proposing to amend the test procedure for consumer water heaters and residential-duty commercial gas water heaters. See 87 FR 1554. DOE published a supplemental test procedure NOPR on July 14, 2022 (July 2022 SNOPR) in the **Federal Register**, proposing certain modifications to the January 2022 NOPR. See 87 FR 42270.

DOE conducted an initial regulatory flexibility analysis (IRFA) as part of the January 2022 NOPR and July 2022 SNOPR. See 87 FR 1554, 1590–1592 (Jan. 11, 2022); 87 FR 42270, 42285–42287 (July 14, 2022). The following sections outline DOE's determination that this final rule does not have a "significant economic impact on a substantial number of small entities," and that the preparation of a FRFA is not warranted. DOE did not receive comment specific to the impacts on small business manufacturers as part of the above-referenced IRFAs.

For manufacturers of consumer water heaters and residential-duty commercial water heaters, the Small Business Administration (SBA) has set a size threshold, which defines those entities classified as "small businesses" for the purposes of the statute. DOE used the SBA's small business size standards to determine whether any small entities would be subject to the requirements of the rule. (See 13 CFR part 121.) The size standards are listed by North American Industry Classification System (NAICS) code and industry description and are available at: www.sba.gov/document/support—table-size-standards. Manufacturing of consumer water heaters and residential-duty commercial water heaters is classified under NAICS 335220, "Major Household Appliance Manufacturing." The SBA sets a threshold of 1,500 employees or fewer for an entity to be considered as a small business for this category. DOE used available public information to identify potential small manufacturers. DOE accessed CCMS,⁷⁹ the certified product directory of the AHRI,⁸⁰ company websites, and manufacturer literature to identify companies that import, private label, or produce the consumer water heaters and residential-duty commercial water heaters covered by this

rulemaking. Using these sources, DOE has identified a total of 27 manufacturers of consumer water heaters and residential-duty commercial water heaters.⁸¹ Of these 27 manufacturers, DOE identified one domestic small business that manufactures products covered by the test procedure amendments.

More specifically, in the January 2022 NOPR IRFA, DOE evaluated a range of potential test procedure amendments, with one amendment that could lead to additional testing costs for small business. The existing DOE test procedure does not accommodate testing of circulating water heaters that require a separately sold hot water storage tank to properly operate. In the January 2022 NOPR, DOE proposed to add procedures to test such circulating water heaters to improve the representativeness of the test procedure. The January 2022 NOPR proposed testing be based on a commonly available 80-gallon unfired hot water storage tank which minimally meets the energy conservation standard requirements at 10 CFR 431.110(a). DOE estimated that the cost of running the amended test procedure should be the same as testing a comparable water heater with storage volume (*i.e.*, third-party testing of a fossil fuel-fired or electric storage water heater would cost approximately \$3,000; third-party testing of an electric storage water heater which uses heat pump technology would cost approximately \$4,500). If a manufacturer chose to perform in-house testing rather than use a third-party, the unfired hot water storage tank was stated to be commercially available for approximately \$900. The January 2022 IRFA identified one small manufacturer and estimated compliance costs to be \$4,500. 87 FR 1554, 1591 (Jan. 11, 2022).

The July 2022 SNOPR further updated DOE's proposal for testing circulating water heaters that require a separately-sold hot water storage tank to properly operate. Specifically, the July 2022 SNOPR differentiated the test requirements for gas-fired circulating water heaters and heat pump circulating water heaters. The July 2022 SNOPR proposed that heat pump circulating water heaters be tested using an electric storage water heaters that have a rated storage volume of 40 gallons \pm 4 gallons, have an FHR that results in classification at the medium draw

pattern, and be rated at exactly the minimum required UEF. Compared to the January 2022 NOPR, DOE revised the requirements for circulating heat pump water heaters to better reflect how heat pump water heaters may be installed in the field. To determine cost of testing, DOE utilized a third-party test estimate of \$4,500. The July 2022 IRFA identified one small manufacturer and estimated compliance costs to be \$4,500. The proposal for heat pump circulating water heaters was the only amendment in the July 2022 SNOPR that could cause the small manufacturer to incur additional costs. 87 FR 42270, 42286–42287 (July 14, 2022).

In this final rule, DOE is establishing testing requirements consistent with the proposal for heat pump circulating water heaters in the July 2022 SNOPR, except that the acceptable volume range for the separate tank has been expanded to 40 gallons \pm 5 gallons. For this final rule, DOE is aware of one domestic small manufacturer. The small manufacturer has a single model (a circulating heat pump water heater that requires a separately-sold hot water tank) that would be affected by the amendments being adopted and that would need to be re-tested. DOE estimates that testing would cost \$4,500. If the manufacturer conducts two rounds of physical testing, DOE expects the cost impact on the small manufacturer to be \$9,000, which is less than 0.01% of company revenue.

DOE has determined the cost impact to small businesses as result of the amendments in this final rule to be minimal. DOE did not receive any comments specifically pertaining to small business impacts. Therefore, on the basis of the *de minimis* compliance burden, DOE certifies that this test procedure final rule does not have a "significant economic impact on a substantial number of small entities," and that the preparation of a FRFA is not warranted. DOE has submitted a certification and supporting statement of factual basis to the Chief Counsel for Advocacy of the Small Business Administration for review under 5 U.S.C. 605(b).

C. Review Under the Paperwork Reduction Act of 1995

Manufacturers of consumer water heaters and manufacturers of residential-duty commercial water heaters must certify to DOE that their products comply with any applicable energy conservation standards. To certify compliance, manufacturers must first obtain test data for their products according to the DOE test procedures, including any amendments adopted for

⁷⁹ U.S. Department of Energy Compliance Certification Management System, available at: www.regulations.doe.gov/ccms. (Last accessed July 19, 2022).

⁸⁰ AHRI Directory of Certified Product Performance is available at: www.ahridirectory.org/Search/SearchHome (Last accessed July 19, 2022).

⁸¹ The January 2022 NOPR identified 31 manufacturers. 87 FR 1554, 1591 (Jan. 11, 2022). The July 2022 SNOPR identified 27 manufacturers. The changes reflect revisions based on manufacturer feedback and additional public information.

those test procedures. DOE has established regulations for the certification and recordkeeping requirements for all covered consumer products and commercial equipment, including consumer water heaters and residential-duty commercial water heaters. (*See generally* 10 CFR part 429.) The collection-of-information requirement for the certification and recordkeeping is subject to review and approval by OMB under the Paperwork Reduction Act (PRA). This requirement has been approved by OMB under OMB control number 1910–1400. Public reporting burden for the certification is estimated to average 35 hours per response, including the time for reviewing instructions, searching existing data sources, gathering and maintaining the data needed, and completing and reviewing the collection of information.

DOE is not amending the certification or reporting requirements for consumer water heaters and residential-duty commercial water heaters in this final rule. Instead, DOE may consider proposals to amend the certification requirements and reporting for these products and equipment under a separate rulemaking regarding appliance and equipment certification. DOE will address changes to OMB Control Number 1910–1400 at that time, as necessary.

Notwithstanding any other provision of the law, no person is required to respond to, nor shall any person be subject to a penalty for failure to comply with, a collection of information subject to the requirements of the PRA, unless that collection of information displays a currently valid OMB Control Number.

D. Review Under the National Environmental Policy Act of 1969

In this final rule, DOE amends the test procedure for consumer water heaters and residential-duty commercial water heaters, amendments which it expects will be used to develop and implement future energy conservation standards for such products and equipment. DOE has determined that this rule falls into a class of actions that are categorically excluded from review under the National Environmental Policy Act of 1969 (42 U.S.C. 4321 *et seq.*) and DOE's implementing regulations at 10 CFR part 1021. Specifically, DOE has determined that adopting test procedures for measuring energy efficiency of consumer products and industrial equipment is consistent with activities identified in 10 CFR part 1021, subpart D, appendix A, sections A5 and A6. Accordingly, neither an environmental

assessment nor an environmental impact statement is required.

E. Review Under Executive Order 13132

Executive Order 13132, "Federalism," 64 FR 43255 (August 10, 1999), imposes certain requirements on agencies formulating and implementing policies or regulations that preempt State law or that have federalism implications. The Executive order requires agencies to examine the constitutional and statutory authority supporting any action that would limit the policymaking discretion of the States and to carefully assess the necessity for such actions. The Executive order also requires agencies to have an accountable process to ensure meaningful and timely input by State and local officials in the development of regulatory policies that have federalism implications. On March 14, 2000, DOE published a statement of policy describing the intergovernmental consultation process it will follow in the development of such regulations. 65 FR 13735. DOE examined this final rule and determined that it will not have a substantial direct effect on the States, on the relationship between the national government and the States, or on the distribution of power and responsibilities among the various levels of government. EPCA governs and prescribes Federal preemption of State regulations as to energy conservation for the products and equipment that are the subject of this final rule. States can petition DOE for exemption from such preemption to the extent, and based on criteria, set forth in EPCA. (42 U.S.C. 6297(d)) No further action is required by Executive Order 13132.

F. Review Under Executive Order 12988

Regarding the review of existing regulations and the promulgation of new regulations, section 3(a) of Executive Order 12988, "Civil Justice Reform," 61 FR 4729 (Feb. 7, 1996), imposes on Federal agencies the general duty to adhere to the following requirements: (1) eliminate drafting errors and ambiguity; (2) write regulations to minimize litigation; (3) provide a clear legal standard for affected conduct rather than a general standard; and (4) promote simplification and burden reduction. Section 3(b) of Executive Order 12988 specifically requires that Executive agencies make every reasonable effort to ensure that the regulation: (1) clearly specifies the preemptive effect, if any; (2) clearly specifies any effect on existing Federal law or regulation; (3) provides a clear legal standard for affected conduct while promoting simplification and

burden reduction; (4) specifies the retroactive effect, if any; (5) adequately defines key terms; and (6) addresses other important issues affecting clarity and general draftsmanship under any guidelines issued by the Attorney General. Section 3(c) of Executive Order 12988 requires executive agencies to review regulations in light of applicable standards in sections 3(a) and 3(b) to determine whether they are met or it is unreasonable to meet one or more of them. DOE has completed the required review and determined that, to the extent permitted by law, this final rule meets the relevant standards of Executive Order 12988.

G. Review Under the Unfunded Mandates Reform Act of 1995

Title II of the Unfunded Mandates Reform Act of 1995 (UMRA) requires each Federal agency to assess the effects of Federal regulatory actions on State, local, and Tribal governments and the private sector. Public Law 104–4, sec. 201 (codified at 2 U.S.C. 1531). For a regulatory action resulting in a rule that may cause the expenditure by State, local, and Tribal governments, in the aggregate, or by the private sector of \$100 million or more in any one year (adjusted annually for inflation), section 202 of UMRA requires a Federal agency to publish a written statement that estimates the resulting costs, benefits, and other effects on the national economy. (2 U.S.C. 1532(a), (b)) The UMRA also requires a Federal agency to develop an effective process to permit timely input by elected officers of State, local, and Tribal governments on a proposed "significant intergovernmental mandate," and requires an agency plan for giving notice and opportunity for timely input to potentially affected small governments before establishing any requirements that might significantly or uniquely affect small governments. On March 18, 1997, DOE published a statement of policy on its process for intergovernmental consultation under UMRA. 62 FR 12820; also available at www.energy.gov/gc/office-general-counsel. DOE examined this final rule according to UMRA and its statement of policy and determined that the rule contains neither an intergovernmental mandate, nor a mandate that may result in the expenditure of \$100 million or more in any year, so these requirements do not apply.

H. Review Under the Treasury and General Government Appropriations Act, 1999

Section 654 of the Treasury and General Government Appropriations

Act, 1999 (Pub. L. 105–277) requires Federal agencies to issue a Family Policymaking Assessment for any rule that may affect family well-being. This final rule will not have any impact on the autonomy or integrity of the family as an institution. Accordingly, DOE has concluded that it is not necessary to prepare a Family Policymaking Assessment.

I. Review Under Executive Order 12630

DOE has determined, under Executive Order 12630, “Governmental Actions and Interference with Constitutionally Protected Property Rights,” 53 FR 8859 (March 18, 1988), that this regulation will not result in any takings that might require compensation under the Fifth Amendment to the U.S. Constitution.

J. Review Under Treasury and General Government Appropriations Act, 2001

Section 515 of the Treasury and General Government Appropriations Act, 2001 (44 U.S.C. 3516 note) provides for agencies to review most disseminations of information to the public under guidelines established by each agency pursuant to general guidelines issued by OMB. OMB’s guidelines were published at 67 FR 8452 (Feb. 22, 2002), and DOE’s guidelines were published at 67 FR 62446 (Oct. 7, 2002). Pursuant to OMB Memorandum M–19–15, Improving Implementation of the Information Quality Act (April 24, 2019), DOE published updated guidelines which are available at: www.energy.gov/sites/prod/files/2019/12/f70/DOE

[%20Final%20Updated%20IQA%20Guidelines%20Dec%202019.pdf](#). DOE has reviewed this final rule under the OMB and DOE guidelines and has concluded that it is consistent with applicable policies in those guidelines.

K. Review Under Executive Order 13211

Executive Order 13211, “Actions Concerning Regulations That Significantly Affect Energy Supply, Distribution, or Use,” 66 FR 28355 (May 22, 2001), requires Federal agencies to prepare and submit to OMB, a Statement of Energy Effects for any significant energy action. A “significant energy action” is defined as any action by an agency that promulgated or is expected to lead to promulgation of a final rule, and that: (1) is a significant regulatory action under Executive Order 12866, or any successor order; and (2) is likely to have a significant adverse effect on the supply, distribution, or use of energy; or (3) is designated by the Administrator of OIRA as a significant energy action. For any significant energy action, the agency must give a detailed

statement of any adverse effects on energy supply, distribution, or use if the regulation is implemented, and of reasonable alternatives to the action and their expected benefits on energy supply, distribution, and use.

This regulatory action is not a significant regulatory action under Executive Order 12866. Moreover, it would not have a significant adverse effect on the supply, distribution, or use of energy, nor has it been designated as a significant energy action by the Administrator of OIRA. Therefore, it is not a significant energy action, and, accordingly, DOE has not prepared a Statement of Energy Effects.

L. Review Under Section 32 of the Federal Energy Administration Act of 1974

Under section 301 of the Department of Energy Organization Act (Pub. L. 95–91; 42 U.S.C. 7101), DOE must comply with section 32 of the Federal Energy Administration Act of 1974, as amended by the Federal Energy Administration Authorization Act of 1977. (15 U.S.C. 788; “FEAA”) Section 32 essentially provides in relevant part that, where a proposed rule authorizes or requires use of commercial standards, the notice of proposed rulemaking must inform the public of the use and background of such standards. In addition, section 32(c) requires DOE to consult with the Attorney General and the Chairman of the Federal Trade Commission (FTC) concerning the impact of the commercial or industry standards on competition.

The modifications to the Federal test procedure for consumer water heaters and residential-duty commercial water heaters adopted in this final rule incorporate testing methods contained in certain sections of the following applicable commercial test standards: ASHRAE 41.1–2020, ASTM D2156–09 (RA 2018), and ASHRAE 118.2–2022. DOE has evaluated these standards and is unable to conclude whether they fully comply with the requirements of section 32(b) of the FEAA (*i.e.*, whether it was developed in a manner that fully provides for public participation, comment, and review.) DOE has consulted with both the Attorney General and the Chairman of the FTC about the impact on competition of using the methods contained in these standards and has received no comments objecting to their use.

M. Congressional Notification

As required by 5 U.S.C. 801, DOE will report to Congress on the promulgation of this rule before its effective date. The report will state that it has been

determined that the final rule is not a “major rule” as defined by 5 U.S.C. 804(2).

N. Description of Materials Incorporated by Reference

In this final rule, DOE incorporates by reference the following test standards:

ASHRAE 41.1–2020 prescribes methods for measuring temperature under laboratory and field conditions which are required for system performance tests and for testing heating, ventilating, air-conditioning, and refrigerating components.

ASHRAE 41.6–2014 prescribes methods for measuring the humidity of moist air with instruments.

ASHRAE 118.2–2022 provides test procedures for rating the efficiency and hot water delivery capabilities of directly heated residential water heaters and residential-duty commercial water heaters.

ASTM D2156–09 (RA 2018) provides a test method to evaluate the density of smoke in the flue gases from burning distillate fuels, which is intended primarily for use with home heating equipment burning kerosene or heating oils, and can be used in the laboratory or in the field to compare fuels for clean burning or to compare heating equipment.

ASTM E97–1987 (W1991) provides a method to determine the 45-deg, 0-deg directional reflectance factor of nonfluorescent opaque specimens by means of filter photometers.

Copies of ASHRAE 41.1–2020, ASHRAE 41.6–2014, and ASHRAE 118.2–2022 are reasonably available from the American Society of Heating, Refrigerating, and Air-Conditioning Engineers, Inc., 180 Technology Parkway NW, Peachtree Corners, GA 30092, (800) 527–4723 or (404) 636–8400, or online at: www.ashrae.org.

Copies of ASTM D2156–09 (RA 2018) are reasonably available from ASTM International, 100 Barr Harbor Drive, P.O. Box C700, West Conshohocken, PA 19428–2959 or online at: www.astm.org.

Copies of ASTM E97–1987 (W1991) are reasonably available from standards resellers including GlobalSpec’s Engineering 360 (<https://standards.globalspec.com/std/3801495/astm-e97-82-1987>) and IHS Markit (https://global.ihs.com/doc_detail.cfm?document_name=ASTM%20E97&item_s_key=00020483).

V. Approval of the Office of the Secretary

The Secretary of Energy has approved publication of this final rule.

List of Subjects

10 CFR Part 429

Administrative practice and procedure, Confidential business information, Energy conservation, Household appliances, Imports, Intergovernmental relations, Reporting and recordkeeping requirements, Small businesses.

10 CFR Part 430

Administrative practice and procedure, Confidential business information, Energy conservation, Household appliances, Imports, Incorporation by reference, Intergovernmental relations, Reporting and recordkeeping requirements, Small businesses.

10 CFR Part 431

Administrative practice and procedure, Confidential business information, Energy conservation, Household appliances, Imports, Intergovernmental relations, Laboratories, Reporting and recordkeeping requirements, Small businesses.

Signing Authority

This document of the Department of Energy was signed on May 22, 2023, by Francisco Alejandro Moreno, Acting Assistant Secretary for Energy Efficiency and Renewable Energy, pursuant to delegated authority from the Secretary of Energy. That document with the original signature and date is maintained by DOE. For administrative purposes only, and in compliance with requirements of the Office of the Federal Register, the undersigned DOE **Federal Register** Liaison Officer has been authorized to sign and submit the document in electronic format for publication, as an official document of the Department of Energy. This administrative process in no way alters the legal effect of this document upon publication in the **Federal Register**.

Signed in Washington, DC, on May 24, 2023.

Treana V. Garrett,
Federal Register Liaison Officer, U.S. Department of Energy.

For the reasons stated in the preamble, DOE amends parts 429, 430, and 431 of Chapter II of Title 10, Code of Federal Regulations, as set forth below:

PART 429—CERTIFICATION, COMPLIANCE, AND ENFORCEMENT FOR CONSUMER PRODUCTS AND COMMERCIAL AND INDUSTRIAL EQUIPMENT

■ 1. The authority citation for part 429 continues to read as follows:

Authority: 42 U.S.C. 6291–6317; 28 U.S.C. 2461 note.

■ 2. Amend § 429.70 by revising paragraph (g)(2) and adding paragraph (g)(3) to read as follows:

§ 429.70 Alternative methods for determining energy efficiency and energy use.

* * * * *

(g) * * *

(2) *Electric Storage Water Heaters.*

Rate an untested basic model of an electric storage-type water heater using the first-hour rating or maximum GPM (whichever is applicable under section 5.3.1 of appendix E to subpart B of this part) and uniform energy factor obtained from a tested basic model as the basis for ratings of basic models with other input ratings, provided that certain conditions are met:

(i) For an untested basic model, the represented value of the first-hour rating or maximum GPM and the uniform energy factor is the same as that of a tested basic model, provided that each heating element of the untested basic model is rated at or above the input rating for the corresponding heating element of the tested basic model.

(ii) For an untested basic model having any heating element with an input rating that is lower than that of the corresponding heating element in the tested basic model, the represented value of the first-hour rating or maximum GPM and the uniform energy factor is the same as that of a tested basic model, provided that the first-hour rating for the untested basic model results in the same draw pattern specified in Table I of appendix E for the simulated-use test as was applied to the tested basic model. To establish whether this condition is met, determine the first-hour ratings or maximum GPMs for the tested and the untested basic models in accordance with the procedure described in section 5.3 of 10 CFR part 430, subpart B, appendix E, then compare the appropriate draw pattern specified in Table I of appendix E for the first-hour rating of the tested basic model with that for the untested basic model. If this condition is not met, then the untested basic model must be tested, and the appropriate sampling provisions must be applied to determine its uniform

energy factor in accordance with appendix E and this part.

(3) *Electric Instantaneous Water Heaters.* Rate an untested basic model of an electric instantaneous-type water heater using the first-hour rating or maximum GPM and the uniform energy factor obtained from a tested basic model as a basis for ratings of basic models with other input ratings, provided that certain conditions are met:

(i) For an untested basic model, the represented value of the first-hour rating or maximum GPM and the uniform energy factor is the same as that of a tested basic model, provided that the untested basic model's input is rated at or above the input rating for the corresponding tested basic model.

(ii) For an untested basic model having an input rating that is lower than that of the corresponding tested basic model, the represented value of the first-hour rating or maximum GPM and the uniform energy factor is the same as that of a tested basic model, provided that the first-hour rating or maximum GPM for the untested basic model results in the same draw pattern specified in Table II of appendix E for the 24-hour simulated-use test as was applied to the tested basic model. To establish whether this condition is met, determine the first-hour rating or maximum GPM for the tested and the untested basic models in accordance with the procedure described in section 5.3 of 10 CFR part 430, subpart B, appendix E, then compare the appropriate draw pattern specified in Table II of appendix E for the first-hour rating or maximum GPM of the tested basic model with that for the untested basic model. If this condition is not met, then the untested basic model must be tested, and the appropriate sampling provisions must be applied to determine its uniform energy factor in accordance with appendix E and this part.

* * * * *

■ 3. Amend § 429.134 by adding paragraph (d)(3) to read as follows:

§ 429.134 Product-specific enforcement provisions.

* * * * *

(d) * * *

(3) *Verification of fuel input rate.* The fuel input rate of each tested unit of the basic model will be measured pursuant to the test requirements of section 5.2.3 of 10 CFR part 430, subpart B, appendix E. The measured fuel input rate (either the measured fuel input rate for a single unit sample or the average of the measured fuel input rates for a multiple unit sample) will be compared to the rated input certified by the

manufacturer. The certified rated input will be considered valid only if the measured fuel input rate is within ±2 percent of the certified rated input.

(i) If the certified rated input is found to be valid, then the certified rated input will be used to determine compliance with the associated energy conservation standard.

(ii) If the measured fuel input rate for gas-fired or oil-fired water heating products is not within ±2 percent of the certified rated input, the measured fuel input rate will be used to determine compliance with the associated energy conservation standard.

* * * * *

PART 430—ENERGY CONSERVATION PROGRAM FOR CONSUMER PRODUCTS

■ 4. The authority citation for part 430 continues to read as follows:

Authority: 42 U.S.C. 6291–6309; 28 U.S.C. 2461 note.

■ 5. Amend § 430.2 by adding in alphabetical order definitions for “Circulating water heater”, “Low-temperature water heater”, and “Tabletop water heater” to read as follows:

§ 430.2 Definitions.

* * * * *

Circulating water heater means an instantaneous or heat pump-type water heater that does not have an operational scheme in which the burner, heating element, or compressor initiates and/or terminates heating based on sensing flow; has a water temperature sensor located at the inlet or the outlet of the water heater or in a separate storage tank that is the primary means of initiating and terminating heating; and must be used in combination with a recirculating pump and either a separate storage tank or water circulation loop in order to achieve the water flow and temperature conditions recommended in the manufacturer’s installation and operation instructions.

* * * * *

Low-temperature water heater means an electric instantaneous water heater that is not a circulating water heater and cannot deliver water at a temperature greater than or equal to the set point temperature specified in section 2.5 of appendix E to subpart B of this part when supplied with water at the supply water temperature specified in section 2.3 of appendix E to subpart B of this part and the flow rate specified in section 5.2.2.1 of appendix E to subpart B of this part.

* * * * *

Tabletop water heater means a heater in a rectangular box enclosure designed to slide into a kitchen countertop space with typical dimensions of 36 inches high, 25 inches deep, and 24 inches wide.

* * * * *

- 6. Section 430.3 is amended by:
 - a. In paragraph (g)(5), removing the text “appendices E, AA” and adding, in its place, the text “appendices AA”;
 - b. Redesignating paragraph (g)(20) as paragraph (g)(22);
 - c. Redesignating paragraph (g)(8) through (19) as paragraphs (g)(9) through (20);
 - d. Adding new paragraph (g)(8);
 - e. In newly redesignated paragraph (g)(13), removing the text “F and EE” and adding, in its place, the text “E, F, and EE”;
 - f. Adding new paragraph (g)(21);
 - g. Revising paragraph (j).

The revisions and additions read as follows:

§ 430.3 Materials incorporated by reference.

* * * * *

(g) * * *

(8) ANSI/ASHRAE Standard 41.1–2020 (“ASHRAE 41.1–2020”), *Standard Methods for Temperature Measurement*, ANSI-approved June 30, 2020; IBR approved for appendix E to subpart B.

* * * * *

(21) ANSI/ASHRAE Standard 118.2–2022 (“ASHRAE 118.2–2022”), *Method of Testing for Rating Residential Water Heaters and Residential-Duty Commercial Water Heaters*, ANSI-approved March 1, 2022; IBR approved for appendix E to subpart B.

* * * * *

(j) *ASTM*. ASTM International, 100 Barr Harbor Drive, P.O. Box C700, West Conshohocken, PA 19428–2959; 877–909–2786; *service@astm.org*; *www.astm.org*.

(1) ASTM D2156–09 (Reapproved 2013) (“ASTM D2156R13”), *Standard Test Method for Smoke Density in Flue Gases from Burning Distillate Fuels*, approved October 1, 2013; IBR approved for appendix N to subpart B.

(2) ASTM D2156–09 (Reapproved 2018) (“ASTM D2156 (R2018)”), *Standard Test Method for Smoke Density in Flue Gases from Burning Distillate Fuels*, approved October 1, 2018; IBR approved for appendices E, O, and EE to subpart B.

(3) ASTM E97–82 (Reapproved 1987) (“ASTM E97–1987”), *Standard Test Method for Directional Reflectance Factor, 45-deg 0-deg, of Opaque Specimens by Broad-Band Filter Reflectometry*, ASTM-approved October

29, 1982; IBR approved for appendix E to subpart B.

Note 2 to paragraph (j)(3): ASTM E97–1987 was withdrawn in 1991. It is reasonably available from standards resellers including GlobalSpec’s Engineering 360 (<https://standards.globalspec.com/std/3801495/astm-e97-82-1987>) and IHS Markit (https://global.ihs.com/doc_detail.cfm?document_name=ASTM%20E97&item_s_key=00020483).

(4) ASTM E741–11 (Reapproved 2017) (“ASTM E741–11(2017)”), *Standard Test Method for Determining Air Change in a Single Zone Means of a Tracer Gas Dilution* Approved Sept. 1, 2017; IBR approved for appendix FF to subpart B.

* * * * *

■ 7. Appendix E to subpart B of part 430 is revised to read as follows:

Appendix E to Subpart B of Part 430—Uniform Test Method for Measuring the Energy Consumption of Water Heaters

Note: Prior to December 18, 2023, representations with respect to the energy use or efficiency of consumer water heaters covered by this test method, including compliance certifications, must be based on testing conducted in accordance with either this appendix as it now appears or appendix E as it appeared at 10 CFR part 430, subpart B revised as of January 1, 2021.

On and after December 18, 2023, representations with respect to energy use or efficiency of consumer water heaters covered by this test method, including compliance certifications, must be based on testing conducted in accordance with this appendix, except as outlined in the following paragraphs.

Prior to June 17, 2024, representations with respect to the energy use or efficiency of residential-duty commercial water heaters covered by this test method, including compliance certifications, must be based on testing conducted in accordance with either this appendix as it now appears or appendix E as it appeared at 10 CFR part 430, subpart B revised as of January 1, 2021.

On and after June 17, 2024, representations with respect to energy use or efficiency of residential-duty commercial water heaters covered by this test method, including compliance certifications, must be based on testing conducted in accordance with this appendix.

Water heaters subject to section 4.10 of this appendix may optionally apply the requirements in section 4.10 of this appendix prior to the compliance date of a final rule reviewing potential amended energy conservation standards for these products and equipment published after June 21, 2023. After the compliance date of such standards final rule, the requirements of section 4.10 are mandatory.

In addition, certain electric resistance storage water heaters may optionally apply the requirements in section 5.1.2 of this appendix in lieu of the requirements in section 5.1.1 of this appendix for additional

voluntary representations only. Water heaters must certify according to the requirements in section 5.1.1 until the publication of a final rule reviewing potential amended energy conservation standards and specifying the required use of section 5.1.2 for these products published after June 21, 2023.

0. Incorporation by Reference.

DOE incorporated by reference in § 430.3 the entire standard for: ASHRAE 41.1–2020; ASHRAE 41.6–2014; ASHRAE 118.2–2022; ASTM D2156–09 (R2018); and ASTM E97–1987. However, only enumerated provisions of ASHRAE 118.2–2022 are applicable to this appendix, as follows:

0.1 ASHRAE 118.2–2022

(a) Annex B—Gas Heating Value Correction Factor;

(b) [Reserved]

0.2 [Reserved]

1. Definitions.

1.1. *Cut-in* means the time when or water temperature at which a water heater control or thermostat acts to increase the energy or fuel input to the heating elements, compressor, or burner.

1.2. *Cut-out* means the time when or water temperature at which a water heater control or thermostat acts to reduce to a minimum the energy or fuel input to the heating elements, compressor, or burner.

1.3. *Design Power Rating* means the power rating or input rate that a water heater manufacturer assigns to a particular design of water heater and that is included on the nameplate of the water heater, expressed in kilowatts or Btu (kJ) per hour as appropriate. For modulating water heaters, the design power rating is the maximum power rating or input rate that is specified by the manufacturer on the nameplate of the water heater.

1.4. *Draw Cluster* means a collection of water draws initiated during the 24-hour simulated-use test during which no successive draws are separated by more than 2 hours.

1.5. *First-Hour Rating* means an estimate of the maximum volume of “hot” water that a non-flow activated water heater can supply within an hour that begins with the water heater fully heated (*i.e.*, with all thermostats satisfied).

1.6. *Flow-Activated* describes an operational scheme in which a water heater initiates and terminates heating based on sensing flow.

1.7. *Heat Trap* means a device that can be integrally connected or independently attached to the hot and/or cold water pipe connections of a water heater such that the device will develop a thermal or mechanical seal to minimize the recirculation of water due to thermal convection between the water heater tank and its connecting pipes.

1.8. *Maximum GPM (L/min) Rating* means the maximum gallons per minute (liters per minute) of hot water that can be supplied by a flow-activated water heater when tested in accordance with section 5.3.2 of this appendix.

1.9. *Modulating Water Heater* means a water heater that can automatically vary its power or input rate from the minimum to the maximum power or input rate specified on the nameplate of the water heater by the manufacturer.

1.10. *Rated Storage Volume* means the water storage capacity of a water heater, in gallons (liters), as certified by the manufacturer pursuant to 10 CFR part 429.

1.11. *Recovery Efficiency* means the ratio of energy delivered to the water to the energy content of the fuel consumed by the water heater.

1.12. *Recovery Period* means the time when the main burner of a water heater with a rated storage volume greater than or equal to 2 gallons is raising the temperature of the stored water.

1.13. *Split-system heat pump water heater* means a heat pump-type water heater in which at least the compressor, which may be installed outdoors, is separate from the storage tank.

1.14. *Standby* means the time, in hours, during which water is not being withdrawn from the water heater.

1.15. *Symbol Usage.* The following identity relationships are provided to help clarify the symbology used throughout this procedure:

C_p —specific heat of water

E_{annual} —annual energy consumption of a water heater

$E_{\text{annual,e}}$ —annual electrical energy consumption of a water heater

$E_{\text{annual,f}}$ —annual fossil-fuel energy consumption of a water heater

E_x —energy efficiency of a heat pump-type water heater when the 24-hour simulated use test is optionally conducted at any of the additional air temperature conditions as specified in section 2.8 of this appendix, where the subscript “X” corresponds to the dry-bulb temperature at which the test is conducted.

F_{hr} —first-hour rating of a non-flow activated water heater

F_{max} —maximum GPM (L/min) rating of a flow-activated water heater

i —a subscript to indicate the draw number during a test

k_v —storage tank volume scaling ratio for water heaters with a rated storage volume greater than or equal to 2 gallons

$M_{\text{del},i}$ —mass of water removed during the i th draw of the 24-hour simulated-use test

$M_{\text{in},i}$ —mass of water entering the water heater during the i th draw of the 24-hour simulated-use test

$M_{\text{del},i}^*$ —for non-flow activated water heaters, mass of water removed during the i th draw during the first-hour rating test

$M_{\text{in},i}^*$ —for non-flow activated water heaters, mass of water entering the water heater during the i th draw during the first-hour rating test

$M_{\text{del},10m}$ —for flow-activated water heaters, mass of water removed continuously during the maximum GPM (L/min) rating test

$M_{\text{in},10m}$ —for flow-activated water heaters, mass of water entering the water heater continuously during the maximum GPM (L/min) rating test

n —for non-flow activated water heaters, total number of draws during the first-hour rating test

N —total number of draws during the 24-hour simulated-use test

N_r —number of draws from the start of the 24-hour simulated-use test to the end of the first recovery period as described in section 5.4.2 of this appendix

Q —total fossil fuel and/or electric energy consumed during the entire 24-hour simulated-use test

Q_d —daily water heating energy consumption adjusted for net change in internal energy

Q_{da} — Q_d with adjustment for variation of tank to ambient air temperature difference from nominal value

Q_{dm} —overall adjusted daily water heating energy consumption including Q_{da} and Q_{HWD}

Q_e —total electrical energy used during the 24-hour simulated-use test

Q_f —total fossil fuel energy used by the water heater during the 24-hour simulated-use test

Q_{hr} —hourly standby losses of a water heater with a rated storage volume greater than or equal to 2 gallons

Q_{HW} —daily energy consumption to heat water at the measured average temperature rise across the water heater

$Q_{HW,67^\circ F}$ —daily energy consumption to heat quantity of water removed during test over a temperature rise of 67 °F (37.3 °C)

Q_{HWD} —adjustment to daily energy consumption, Q_{HW} , due to variation of the temperature rise across the water heater not equal to the nominal value of 67 °F (37.3 °C)

Q_r —energy consumption of water heater from the beginning of the test to the end of the first recovery period

Q_{stby} —total energy consumed during the standby time interval $\tau_{\text{stby},1}$, as determined in section 5.4.2 of this appendix

$Q_{\text{su},0}$ —cumulative energy consumption, including all fossil fuel and electrical energy use, of the water heater from the start of the 24-hour simulated-use test to the start of the standby period as determined in section 5.4.2 of this appendix

$Q_{\text{su},1}$ —cumulative energy consumption, including all fossil fuel and electrical energy use, of the water heater from the start of the 24-hour simulated-use test to the end of the standby period as determined in section 5.4.2 of this appendix

\bar{T}_0 —mean tank temperature at the beginning of the 24-hour simulated-use test as determined in section 5.4.2 of this appendix

\bar{T}_{24} —mean tank temperature at the end of the 24-hour simulated-use test as determined in section 5.4.2 of this appendix

$\bar{T}_{a,\text{stby}}$ —average ambient air temperature during all standby periods of the 24-hour simulated-use test as determined in section 5.4.2 of this appendix

$\bar{T}_{a,\text{stby},1}$ —overall average ambient temperature between the start and end of the standby period as determined in section 5.4.2 of this appendix

$\bar{T}_{t,\text{stby},1}$ —overall average mean tank temperature between the start and end of the standby period as determined in section 5.4.2 of this appendix

\bar{T}_{del} —for flow-activated water heaters, average outlet water temperature during the maximum GPM (L/min) rating test

$\bar{T}_{\text{del},i}$ —average outlet water temperature during the i th draw of the 24-hour simulated-use test

\bar{T}_{in} —for flow-activated water heaters, average inlet water temperature during the maximum GPM (L/min) rating test

\bar{T}_{st} —for water heaters which cannot have internal tank temperature directly measured, estimated average internal storage tank temperature

T_p —for water heaters which cannot have internal tank temperature directly measured, average of the inlet and the outlet water temperatures at the end of the period defined by τ_p

$\bar{T}_{in,p}$ —for water heaters which cannot have internal tank temperature directly measured, average of the inlet water temperatures

$\bar{T}_{out,p}$ —for water heaters which cannot have internal tank temperature directly measured, average of the outlet water temperatures

$\bar{T}_{in,i}$ —average inlet water temperature during the i th draw of the 24-hour simulated-use test

$\bar{T}_{max,1}$ —maximum measured mean tank temperature after the first recovery period of the 24-hour simulated-use test as determined in section 5.4.2 of this appendix

$\bar{T}_{su,0}$ —maximum measured mean tank temperature at the beginning of the standby period as determined in section 5.4.2 of this appendix

$\bar{T}_{su,t}$ —measured mean tank temperature at the end of the standby period as determined in section 5.4.2 of this appendix

$\bar{T}_{del,i}^*$ —for non-flow activated water heaters, average outlet water temperature during the i th draw ($i = 1$ to n) of the first-hour rating test

$\bar{T}_{max,i}^*$ —for non-flow activated water heaters, maximum outlet water temperature observed during the i th draw ($i = 1$ to n) of the first-hour rating test

$\bar{T}_{min,i}^*$ —for non-flow activated water heaters, minimum outlet water temperature to terminate the i th draw ($i = 1$ to n) of the first-hour rating test

UA —standby loss coefficient of a water heater with a rated storage volume greater than or equal to 2 gallons

UEF —uniform energy factor of a water heater

V —the volume of hot water drawn during the applicable draw pattern

$V_{del,i}$ —volume of water removed during the i th draw ($i = 1$ to N) of the 24-hour simulated-use test

$V_{in,i}$ —volume of water entering the water heater during the i th draw ($i = 1$ to N) of the 24-hour simulated-use test

$V_{del,i}^*$ —for non-flow activated water heaters, volume of water removed during the i th draw ($i = 1$ to n) of the first-hour rating test

$V_{in,i}^*$ —for non-flow activated water heaters, volume of water entering the water heater during the i th draw ($i = 1$ to n) of the first-hour rating test

$V_{del,10m}$ —for flow-activated water heaters, volume of water removed during the maximum GPM (L/min) rating test

$V_{in,10m}$ —for flow-activated water heaters, volume of water entering the water heater during the maximum GPM (L/min) rating test

V_{st} —measured storage volume of the storage tank for water heaters with a rated storage volume greater than or equal to 2 gallons

V_{eff} —effective storage volume

$v_{out,p}$ —for water heaters which cannot have internal tank temperature directly measured, average flow rate

W_f —weight of storage tank when completely filled with water for water heaters with a rated storage volume greater than or equal to 2 gallons

W_r —tare weight of storage tank when completely empty of water for water heaters with a rated storage volume greater than or equal to 2 gallons

η —recovery efficiency

ρ —density of water

τ_p —for water heaters which cannot have internal tank temperature directly measured, duration of the temperature measurement period, determined by the length of time taken for the outlet water temperature to be within 2 °F of the inlet water temperature for 15 consecutive seconds (including the 15-second stabilization period)

$\tau_{stby,1}$ —elapsed time between the start and end of the standby period as determined in section 5.4.2 of this appendix

$\tau_{stby,2}$ —overall time of standby periods when no water is withdrawn during the 24-hour simulated-use test as determined in section 5.4.2 of this appendix

1.16. *Temperature Controller* means a device that is available to the user to adjust the temperature of the water inside a water heater that stores heated water or the outlet water temperature.

1.17. *Thermal break* means a thermally non-conductive material that can withstand a pressure of 150 psi (1.034 MPa) at a temperature greater than the maximum temperature the water heater is designed to produce and is utilized to insulate a bypass loop, if one is used in the test set-up, from the inlet piping.

1.18. *Uniform Energy Factor* means the measure of water heater overall efficiency.

1.19. *Water Heater Requiring a Storage Tank* means a water heater without a storage tank specified or supplied by the manufacturer that cannot meet the requirements of sections 2 and 5 of this appendix without the use of a storage water heater or unfired hot water storage tank.

2. Test Conditions.

2.1 *Installation Requirements.* Tests shall be performed with the water heater and instrumentation installed in accordance with section 4 of this appendix.

2.2 Ambient Air Temperature and Relative Humidity.

2.2.1 *Non-Heat Pump Water Heaters.* The ambient air temperature shall be maintained between 65.0 °F and 70.0 °F (18.3 °C and 21.1 °C) on a continuous basis.

2.2.2 *Heat Pump Water Heaters.* The dry-bulb temperature shall be maintained at an average of 67.5 °F \pm 1 °F (19.7 °C \pm 0.6 °C) after a cut-in and before the next cut-out, an average of 67.5 °F \pm 2.5 °F (19.7 °C \pm 1.4 °C) after a cut-out and before the next cut-in, and at 67.5 °F \pm 5 °F (19.7 °C \pm 2.8 °C) on a continuous basis throughout the test. The relative humidity shall be maintained within a range of 50% \pm 5% throughout the test, and at an average of 50% \pm 2% after a cut-in and before the next cut-out.

When testing a split-system heat pump water heater or heat pump water heater

requiring a separate storage tank, the heat pump portion of the system shall be tested at the conditions within this section and the separate water heater or unfired hot water storage tank shall be tested at either the conditions within this section or the conditions specified in section 2.2.1 of this appendix.

2.3 *Supply Water Temperature.* The temperature of the water being supplied to the water heater shall be maintained at 58 °F \pm 2 °F (14.4 °C \pm 1.1 °C) throughout the test.

2.4 *Outlet Water Temperature.* The temperature controllers of a non-flow activated water heater shall be set so that water is delivered at a temperature of 125 °F \pm 5 °F (51.7 °C \pm 2.8 °C).

2.5 *Set Point Temperature.* The temperature controller of a flow-activated water heater shall be set to deliver water at a temperature of 125 °F \pm 5 °F (51.7 °C \pm 2.8 °C). If the flow-activated water heater is not capable of delivering water at a temperature of 125 °F \pm 5 °F (51.7 °C \pm 2.8 °C) when supplied with water at the supply water temperature specified in section 2.3 of this appendix, then the flow-activated water heater shall be set to deliver water at its maximum water temperature.

2.6 *Supply Water Pressure.* During the test when water is not being withdrawn, the supply pressure shall be maintained between 40 psig (275 kPa) and the maximum allowable pressure specified by the water heater manufacturer.

2.7 Electrical and/or Fossil Fuel Supply.

2.7.1 *Electrical.* Maintain the electrical supply voltage to within \pm 2% of the center of the voltage range specified on the nameplate of the water heater by the water heater and/or heat pump manufacturer, from 5 seconds after a cut-in to 5 seconds before next cut-out.

2.7.2 *Natural Gas.* Maintain the supply pressure in accordance with the supply pressure specified on the nameplate of the water heater by the manufacturer. If the supply pressure is not specified, maintain a supply pressure of 7–10 inches of water column (1.7–2.5 kPa). If the water heater is equipped with a gas appliance pressure regulator and the gas appliance pressure regulator can be adjusted, the regulator outlet pressure shall be within the greater of \pm 10% of the manufacturer's specified manifold pressure, found on the nameplate of the water heater, or \pm 0.2 inches water column (0.05 kPa). Maintain the gas supply pressure and manifold pressure only when operating at the design power rating. For all tests, use natural gas having a heating value of approximately 1,025 Btu per standard cubic foot (38,190 kJ per standard cubic meter).

2.7.3 *Propane Gas.* Maintain the supply pressure in accordance with the supply pressure specified on the nameplate of the water heater by the manufacturer. If the supply pressure is not specified, maintain a supply pressure of 11–13 inches of water column (2.7–3.2 kPa). If the water heater is equipped with a gas appliance pressure regulator and the gas appliance pressure regulator can be adjusted, the regulator outlet pressure shall be within the greater of \pm 10% of the manufacturer's specified manifold pressure, found on the nameplate of the

water heater, or ±0.2 inches water column (0.05 kPa). Maintain the gas supply pressure and manifold pressure only when operating at the design power rating. For all tests, use propane gas with a heating value of approximately 2,500 Btu per standard cubic foot (93,147 kJ per standard cubic meter).

2.7.4 *Fuel Oil Supply.* Maintain an uninterrupted supply of fuel oil. The fuel pump pressure shall be within ±10% of the pump pressure specified on the nameplate of the water heater or the installation and

operations (I&O) manual by the manufacturer. Use fuel oil having a heating value of approximately 138,700 Btu per gallon (38,660 kJ per liter).

2.8 *Optional Test Conditions (Heat Pump-Type Water Heaters).* The following test conditions may be used for optional representations of E_x for heat pump-type water heaters. When conducting a 24-hour simulated use test to determine E_x, the test conditions in section 2.1 and sections 2.4 through 2.7 apply. The ambient air

temperature and humidity conditions in section 2.2 and the supply water temperature in section 2.3 are replaced with the air temperature, humidity, and supply water temperature conditions as shown in the following table. Testing may optionally be performed at any or all of the conditions in the table, and the sampling plan found at 10 CFR 429.17(a) may be applied for voluntary representations.

Heat pump type	Metric	Outdoor air conditions		Indoor air conditions		Supply water temperature (°F)
		Dry-bulb temperature (°F)	Relative humidity (%)	Dry-bulb temperature (°F)	Relative humidity (%)	
Split-System or Circulating	E ₅	5.0	30	67.5	50	42.0
	E ₃₄	34.0	72	47.0
	E ₉₅	95.0	25	67.0
Integrated, Split-System, or Circulating	E ₅₀	N/A	N/A	50.0	58	50.0
	E ₉₅	N/A	N/A	95.0	40	67.0

3. Instrumentation.

3.1 *Pressure Measurements.* Pressure-measuring instruments shall have an error no greater than the following values:

Item measured	Instrument accuracy	Instrument precision
Gas pressure	±0.1 inch of water column (±0.025 kPa)	±0.05 inch of water column (±0.012 kPa).
Atmospheric pressure	±0.1 inch of mercury column (±0.34 kPa)	±0.05 inch of mercury column (±0.17 kPa).
Water pressure	±1.0 pounds per square inch (±6.9 kPa)	±0.50 pounds per square inch (±3.45 kPa).

3.2 *Temperature Measurement*

3.2.1 *Measurement.* Temperature measurements shall be made in accordance with the Standard Method for Temperature Measurement, ASHRAE 41.1–2020, including

the conditions as specified in ASHRAE 41.6–2014 as referenced in ASHRAE 41.1–2020, and excluding the steady-state temperature criteria in section 5.5 of ASHRAE 41.1–2020.

3.2.2 *Accuracy and Precision.* The accuracy and precision of the instruments, including their associated readout devices, shall be within the following limits:

Item measured	Instrument accuracy	Instrument precision
Air dry-bulb temperature	±0.2 °F (±0.1 °C)	±0.1 °F (±0.06 °C).
Air wet-bulb temperature	±0.2 °F (±0.1 °C)	±0.1 °F (±0.06 °C).
Inlet and outlet water temperatures	±0.2 °F (±0.1 °C)	±0.1 °F (±0.06 °C).
Storage tank temperatures	±0.5 °F (±0.3 °C)	±0.25 °F (±0.14 °C).

3.2.3 *Scale Division.* In no case shall the smallest scale division of the instrument or instrument system exceed 2 times the specified precision.

3.2.4 *Temperature Difference.* Temperature difference between the entering and leaving water may be measured with any of the following:

- (a) A thermopile
- (b) Calibrated resistance thermometers
- (c) Precision thermometers
- (d) Calibrated thermistors
- (e) Calibrated thermocouples
- (f) Quartz thermometers

3.2.5 *Thermopile Construction.* If a thermopile is used, it shall be made from calibrated thermocouple wire taken from a single spool. Extension wires to the recording device shall also be made from that same spool.

3.2.6 *Time Constant.* The time constant of the instruments used to measure the inlet

and outlet water temperatures shall be no greater than 2 seconds.

3.3 *Liquid Flow Rate Measurement.* The accuracy of the liquid flow rate measurement, using the calibration if furnished, shall be equal to or less than ±1% of the measured value in mass units per unit time.

3.4 *Electrical Energy.* The electrical energy used shall be measured with an instrument and associated readout device that is accurate within ±0.5% of the reading.

3.5 *Fossil Fuels.* The quantity of fuel used by the water heater shall be measured with an instrument and associated readout device that is accurate within ±1% of the reading.

3.6 *Mass Measurements.* For mass measurements greater than or equal to 10 pounds (4.5 kg), a scale that is accurate within ±0.5% of the reading shall be used to make the measurement. For mass measurements less than 10 pounds (4.5 kg), the scale shall provide a measurement that is accurate within ±0.1 pound (0.045 kg).

3.7 *Heating Value.* The higher heating value of the natural gas, propane, or fuel oil shall be measured with an instrument and associated readout device that is accurate within ±1% of the reading. The heating values of natural gas and propane must be corrected from those measured to the standard temperature of 60.0 °F (15.6 °C) and standard pressure of 30 inches of mercury column (101.6 kPa) using the method described in Annex B of ASHRAE 118.2–2022.

3.8 *Time.* The elapsed time measurements shall be measured with an instrument that is accurate within ±0.5 seconds per hour.

3.9 *Volume.* Volume measurements shall be measured with an accuracy of ±2% of the total volume.

3.10 *Relative Humidity.* If a relative humidity (RH) transducer is used to measure the relative humidity of the surrounding air while testing heat pump water heaters, the

relative humidity shall be measured with an accuracy of $\pm 1.5\%$ RH.

4. Installation.

4.1 *Water Heater Mounting.* A water heater designed to be freestanding shall be placed on a $\frac{3}{4}$ inch (2 cm) thick plywood platform supported by three 2x4 inch (5 cm x 10 cm) runners. If the water heater is not approved for installation on combustible flooring, suitable non-combustible material shall be placed between the water heater and the platform. Water heaters designed to be installed into a kitchen countertop space shall be placed against a simulated wall section. Wall-mounted water heaters shall be supported on a simulated wall in accordance with the manufacturer-published installation instructions. When a simulated wall is used, the construction shall be 2x4 inch (5 cm x 10 cm) studs, faced with $\frac{3}{4}$ inch (2 cm) plywood. For heat pump water heaters not delivered as a single package, the units shall be connected in accordance with the manufacturer-published installation instructions, and the overall system shall be placed on the above-described plywood platform. If installation instructions are not provided by the heat pump manufacturer, uninsulated 8 foot (2.4 m) long connecting hoses having an inside diameter of $\frac{5}{8}$ inch (1.6 cm) shall be used to connect the storage tank and the heat pump water heater. With the exception of using the storage tank described in section 4.10 of this appendix, the same requirements shall apply for water heaters requiring a storage tank. The testing of the water heater shall occur in an area that is protected from drafts of more than 50 ft/min (0.25 m/s) from room ventilation registers, windows, or other external sources of air movement.

4.2 *Water Supply.* Connect the water heater to a water supply capable of delivering water at conditions as specified in sections 2.3 and 2.6 of this appendix.

4.3 *Water Inlet and Outlet Configuration.* For freestanding water heaters that are taller than 36 inches (91.4 cm), inlet and outlet piping connections shall be configured in a manner consistent with Figures 1 and 2 of section 7 of this appendix. Inlet and outlet piping connections for wall-mounted water heaters shall be consistent with Figure 3 of section 7 of this appendix. For freestanding water heaters that are 36 inches or less in height and not supplied as part of a countertop enclosure (commonly referred to as an under-the-counter model), inlet and outlet piping shall be installed in a manner consistent with Figures 4, 5, or 6 of section 7 of this appendix. For water heaters that are supplied with a counter-top enclosure, inlet and outlet piping shall be made in a manner consistent with Figures 7a and 7b of section 7 of this appendix, respectively. The vertical piping noted in Figures 7a and 7b shall be located (whether inside the enclosure or along the outside in a recessed channel) in accordance with the manufacturer-published installation instructions.

All dimensions noted in Figures 1 through 7 of section 7 of this appendix must be achieved. All piping between the water heater and inlet and outlet temperature sensors, noted as T_{IN} and T_{OUT} in the figures, shall be Type "L" hard copper having the

same diameter as the connections on the water heater. Unions may be used to facilitate installation and removal of the piping arrangements. Install a pressure gauge and diaphragm expansion tank in the supply water piping at a location upstream of the inlet temperature sensor. Install an appropriately rated pressure and temperature relief valve on all water heaters at the port specified by the manufacturer. Discharge piping for the relief valve must be non-metallic. If heat traps, piping insulation, or pressure relief valve insulation are supplied with the water heater, they must be installed for testing. Except when using a simulated wall, provide sufficient clearance such that none of the piping contacts other surfaces in the test room.

At the discretion of the test laboratory, the mass or water delivered may be measured on either the inlet or outlet of the water heater.

For water heaters designed to be used with a mixing valve and that do not have a self-contained mixing valve, a mixing valve shall be installed according to the water heater and/or mixing valve manufacturer's installation instructions. If permitted by the water heater and mixing valve manufacturer's instructions, the mixing valve and cold water junction may be installed where the elbows are located in the outlet and inlet line, respectively. If there are no installation instructions for the mixing valve in the water heater or mixing valve manufacturer's instructions, then the mixing valve shall be installed on the outlet line and the cold water shall be supplied from the inlet line from a junction installed downstream from the location where the inlet water temperature is measured. The outlet water temperature, water flow rate, and/or mass measuring instrumentation, if installed on the outlet side of the water heater, shall be installed downstream from the mixing valve.

4.4 *Fuel and/or Electrical Power and Energy Consumption.* Install one or more instruments that measure, as appropriate, the quantity and rate of electrical energy and/or fossil fuel consumption in accordance with section 3 of this appendix.

4.5 *Internal Storage Tank Temperature Measurements.* For water heaters with rated storage volumes greater than or equal to 20 gallons, install six temperature measurement sensors inside the water heater tank with a vertical distance of at least 4 inches (100 mm) between successive sensors. For water heaters with rated storage volumes between 2 and 20 gallons, install three temperature measurement sensors inside the water heater tank. Position a temperature sensor at the vertical midpoint of each of the six equal volume nodes within a tank larger than 20 gallons or the three equal volume nodes within a tank between 2 and 20 gallons. Nodes designate the equal volumes used to evenly partition the total volume of the tank. As much as is possible, the temperature sensor should be positioned away from any heating elements, anodic protective devices, tank walls, and flue pipe walls. If the tank cannot accommodate six temperature sensors and meet the installation requirements specified in this section, install the maximum number of sensors that comply

with the installation requirements. Install the temperature sensors through:

- The anodic device opening;
- The relief valve opening; or
- The hot water outlet.

If installed through the relief valve opening or the hot water outlet, a tee fitting or outlet piping, as applicable, must be installed as close as possible to its original location. If the relief valve temperature sensor is relocated, and it no longer extends into the top of the tank, install a substitute relief valve that has a sensing element that can reach into the tank. If the hot water outlet includes a heat trap, install the heat trap on top of the tee fitting. Cover any added fittings with thermal insulation having an R value between 4 and 8 h-ft²·°F/Btu (0.7 and 1.4 m²·°C/W). If temperature measurement sensors cannot be installed within the water heater, follow the alternate procedures in section 5.4.2.2 of this appendix.

4.6 *Ambient Air Temperature Measurement.* Install an ambient air temperature sensor at the vertical midpoint of the water heater and approximately 2 feet (610 mm) from the surface of the water heater. Shield the sensor against radiation.

4.7 *Inlet and Outlet Water Temperature Measurements.* Install temperature sensors in the cold-water inlet pipe and hot-water outlet pipe as shown in Figures 1, 2, 3, 4, 5, 6, 7a, and 7b of section 7 of this appendix, as applicable.

4.8 *Flow Control.* Install a valve or valves to provide flow as specified in sections 5.3 and 5.4 of this appendix.

4.9 Flue Requirements.

4.9.1 *Gas-Fired Water Heaters.* Establish a natural draft in the following manner. For gas-fired water heaters with a vertically discharging draft hood outlet, connect to the draft hood outlet a 5-foot (1.5-meter) vertical vent pipe extension with a diameter equal to the largest flue collar size of the draft hood. For gas-fired water heaters with a horizontally discharging draft hood outlet, connect to the draft hood outlet a 90-degree elbow with a diameter equal to the largest flue collar size of the draft hood, connect a 5-foot (1.5-meter) length of vent pipe to that elbow, and orient the vent pipe to discharge vertically upward. Install direct-vent gas-fired water heaters with venting equipment specified by the manufacturer in the I&O manual using the minimum vertical and horizontal lengths of vent pipe recommended by the manufacturer.

4.9.2 *Oil-Fired Water Heaters.* Establish a draft at the flue collar at the value specified by the manufacturer in the I&O manual. Establish the draft by using a sufficient length of vent pipe connected to the water heater flue outlet, and directed vertically upward. For an oil-fired water heater with a horizontally discharging draft hood outlet, connect to the draft hood outlet a 90-degree elbow with a diameter equal to the largest flue collar size of the draft hood, connect to the elbow fitting a length of vent pipe sufficient to establish the draft, and orient the vent pipe to discharge vertically upward. Direct-vent oil-fired water heaters should be installed with venting equipment as specified by the manufacturer in the I&O manual, using the minimum vertical and horizontal

lengths of vent pipe recommended by the manufacturer.

4.10 *Storage Tank Requirement for Circulating Water Heaters.* On or after the compliance date of a final rule reviewing potential amended energy conservation standards for these products published after June 21, 2023, when testing a gas-fired, oil-fired, or electric resistance circulating water heater (*i.e.*, any circulating water heater that does not use a heat pump), the tank to be used for testing shall be an unfired hot water storage tank having volume between 80 and 120 gallons (364–546 liters) determined using the method specified in section 5.2.1 that meets but does not exceed the minimum energy conservation standards required according to 10 CFR 431.110. When testing a heat pump circulating water heater, the tank to be used for testing shall be an electric storage water heater that has a measured volume of 40 gallons (± 5 gallons), has a First-Hour Rating greater than or equal to 51 gallons and less than 75 gallons resulting in classification under the medium draw pattern, and has a rated UEF equal to the minimum UEF standard specified at § 430.32(d), rounded to the nearest 0.01. The operational mode of the heat pump circulating water heater and storage water heater paired system shall be set in accordance with section 5.1.1 of this appendix. If the circulating water heater is supplied with a separate non-integrated circulating pump, install this pump as per the manufacturer's installation instructions and include its power consumption in energy use measurements.

4.11 *External Communication.* If the water heater can connect to an external network or controller, any external communication or connection shall be disabled for the duration of testing; however, the communication module shall remain in an "on" state.

5. Test Procedures.

5.1 *Operational Mode Selection.* For water heaters that allow for multiple user-selected operational modes, all procedures specified in this appendix shall be carried out with the water heater in the same operational mode (*i.e.*, only one mode).

5.1.1 *Testing at Normal Setpoint.* The operational mode shall be the default mode (or similarly named, suggested mode for normal operation) as defined by the manufacturer in the I&O manual for giving selection guidance to the consumer. For heat pump water heaters, if a default mode is not defined in the product literature, each test shall be conducted under an operational mode in which both the heat pump and any electric resistance back-up heating element(s) are activated by the unit's control scheme, and which can achieve the internal storage tank temperature specified in this test procedure; if multiple operational modes meet these criteria, the water heater shall be tested under the most energy-intensive mode. If no default mode is specified and the unit does not offer an operational mode that utilizes both the heat pump and the electric resistance back-up heating element(s), the first-hour rating test and the 24-hour simulated-use test shall be tested in heat-pump-only mode. For other types of water

heaters where a default mode is not specified, test the unit in all modes and rate the unit using the results of the most energy-intensive mode.

5.1.2 *High Temperature Testing.* This paragraph applies to electric storage water heaters that are capable of heating their stored water above the target delivery temperature without initiation from a utility or third-party demand-response program, except for those that meet the definition of "heat pump-type" water heater at 10 CFR 430.2.

For those equipped with factory-installed or built-in mixing valves, set the unit to maintain the highest mean tank temperature possible while delivering water at $125\text{ }^{\circ}\text{F} \pm 5\text{ }^{\circ}\text{F}$. For those not so equipped, install an ASSE 1017-certified mixing valve in accordance with the provisions in section 4.3 and adjust the valve to deliver water at $125\text{ }^{\circ}\text{F} \pm 5\text{ }^{\circ}\text{F}$ when the water heater is operating at its highest storage tank temperature setpoint. Maintain this setting throughout the entirety of the test.

5.2 Water Heater Preparation.

5.2.1 *Determination of Storage Tank Volume.* For water heaters with a rated storage volume greater than or equal to 2 gallons and for separate storage tanks used for testing circulating water heaters, determine the storage capacity, V_{st} , of the water heater or separate storage tank under test, in gallons (liters), by subtracting the tare weight, W_t , (measured while the tank is empty) from the gross weight of the storage tank when completely filled with water at the supply water temperature specified in section 2.3 of this appendix, W_r , (with all air eliminated and line pressure applied as described in section 2.6 of this appendix) and dividing the resulting net weight by the density of water at the measured temperature.

5.2.2 Setting the Outlet Discharge Temperature.

5.2.2.1 *Flow-Activated Water Heaters, including certain instantaneous water heaters and certain storage-type water heaters.* Initiate normal operation of the water heater at the design power rating. Monitor the discharge water temperature and set to the value specified in section 2.5 of this appendix in accordance with the manufacturer's I&O manual. If the water heater is not capable of providing this discharge temperature when the flow rate is 1.7 gallons \pm 0.25 gallons per minute (6.4 liters \pm 0.95 liters per minute), then adjust the flow rate as necessary to achieve the specified discharge water temperature. Once the proper temperature control setting is achieved, the setting must remain fixed for the duration of the maximum GPM test and the 24-hour simulated-use test.

5.2.2.2 All Other Water Heaters.

5.2.2.2.1 Water Heaters with a Single Temperature Controller.

5.2.2.2.1.1 *Water Heaters with Rated Volumes Less than 20 Gallons.* Starting with a tank at the supply water temperature as specified in section 2.3 of this appendix, initiate normal operation of the water heater. After cut-out, initiate a draw from the water heater at a flow rate of 1.0 gallon \pm 0.25 gallons per minute (3.8 liters \pm 0.95 liters per

minute) for 2 minutes. Starting 15 seconds after commencement of the draw, record the outlet temperature at 15-second intervals until the end of the 2-minute period. Determine whether the maximum outlet temperature is within the range specified in section 2.4 of this appendix. If not, turn off the water heater, adjust the temperature controller, and then drain and refill the tank with supply water at the temperature specified in section 2.3 of this appendix. Then, once again, initiate normal operation of the water heater, and repeat the 2-minute outlet temperature test following cut-out. Repeat this sequence until the maximum outlet temperature during the 2-minute test is within the range specified in section 2.4 of this appendix. Once the proper temperature control setting is achieved, the setting must remain fixed for the duration of the first-hour rating test and the 24-hour simulated-use test.

5.2.2.2.1.2 Water Heaters with Rated Volumes Greater than or Equal to 20 Gallons.

Starting with a tank at the supply water temperature specified in section 2.3 of this appendix, initiate normal operation of the water heater. After cut-out, initiate a draw from the water heater at a flow rate of 1.7 gallons \pm 0.25 gallons per minute (6.4 liters \pm 0.95 liters per minute) for 5 minutes. Starting 15 seconds after commencement of the draw, record the outlet temperature at 15-second intervals until the end of the 5-minute period. Determine whether the maximum outlet temperature is within the range specified in section 2.4 of this appendix. If not, turn off the water heater, adjust the temperature controller, and then drain and refill the tank with supply water at the temperature specified in section 2.3 of this appendix. Then, once again, initiate normal operation of the water heater, and repeat the 5-minute outlet temperature test following cut-out. Repeat this sequence until the maximum outlet temperature during the 5-minute test is within the range specified in section 2.4 of this appendix. Once the proper temperature control setting is achieved, the setting must remain fixed for the duration of the first-hour rating test and the 24-hour simulated-use test.

5.2.2.2.2 *Water Heaters with Two or More Temperature Controllers.* Verify the temperature controller set-point while removing water in accordance with the procedure set forth for the first-hour rating test in section 5.3.3 of this appendix. The following criteria must be met to ensure that all temperature controllers are set to deliver water in the range specified in section 2.4 of this appendix:

(a) At least 50 percent of the water drawn during the first draw of the first-hour rating test procedure shall be delivered at a temperature within the range specified in section 2.4 of this appendix.

(b) No water is delivered above the range specified in section 2.4 of this appendix during first-hour rating test.

(c) The delivery temperature measured 15 seconds after commencement of each draw begun prior to an elapsed time of 60 minutes from the start of the test shall be within the range specified in section 2.4 of this appendix.

If these conditions are not met, turn off the water heater, adjust the temperature controllers, and then drain and refill the tank with supply water at the temperature specified in section 2.3 of this appendix. Repeat the procedure described at the start of section 5.2.2.2 of this appendix until the criteria for setting the temperature controllers is met.

If the conditions stated above are met, the data obtained during the process of verifying the temperature control set-points may be used in determining the first-hour rating provided that all other conditions and methods required in sections 2 and 5.2.4 of this appendix in preparing the water heater were followed.

5.2.3 Power Input Determination. For all water heaters except electric types, initiate normal operation (as described in section 5.1 of this appendix) and determine the power input, P , to the main burners (including pilot light power, if any) after 15 minutes of operation. Adjust all burners to achieve an hourly Btu (kJ) rating that is within $\pm 2\%$ of the maximum input rate value specified by the manufacturer. For an oil-fired water heater, adjust the burner to give a CO_2 reading recommended by the manufacturer and an hourly Btu (kJ) rating that is within $\pm 2\%$ of the maximum input rate specified by the manufacturer. Smoke in the flue may not exceed No. 1 smoke as measured by the procedure in ASTM D2156 (R2018), including the conditions as specified in ASTM E97–1987 as referenced in ASTM D2156 (R2018). If the input rating is not within $\pm 2\%$, first increase or decrease the fuel pressure within the tolerances specified in section 2.7.2, 2.7.3 or 2.7.4 (as applicable) of this appendix until it is $\pm 2\%$ of the maximum input rate value specified by the manufacturer. If, after adjusting the fuel pressure, the fuel input rate cannot be achieved within ± 2 percent of the maximum input rate value specified by the manufacturer, for gas-fired models increase or decrease the gas supply pressure within the range specified by the manufacturer. Finally, if the measured fuel input rate is still not within ± 2 percent of the maximum input rate value specified by the manufacturer, modify the gas inlet orifice, if so equipped, as necessary to achieve a fuel input rate that is within ± 2 percent of the maximum input rate value specified by the manufacturer.

5.2.4 Soak-In Period for Water Heaters with Rated Storage Volumes Greater than or Equal to 2 Gallons. For water heaters with a rated storage volume greater than or equal to 2 gallons (7.6 liters), the water heater must sit filled with water, connected to a power source, and without any draws taking place for at least 12 hours after initially being energized so as to achieve the nominal temperature set-point within the tank and with the unit connected to a power source.

5.3 Delivery Capacity Tests.

5.3.1 General. For flow-activated water heaters, conduct the maximum GPM test, as described in section 5.3.2, Maximum GPM Rating Test for Flow-Activated Water Heaters, of this appendix. For all other water heaters, conduct the first-hour rating test as described in section 5.3.3 of this appendix.

5.3.2 Maximum GPM Rating Test for Flow-Activated Water Heaters. Establish

normal water heater operation at the design power rating with the discharge water temperature set in accordance with section 5.2.2.1 of this appendix.

For this 10-minute test, either collect the withdrawn water for later measurement of the total mass removed or use a water meter to directly measure the water mass or volume removed. Initiate water flow through the water heater and record the inlet and outlet water temperatures beginning 15 seconds after the start of the test and at subsequent 5-second intervals throughout the duration of the test. At the end of 10 minutes, turn off the water. Determine and record the mass of water collected, M_{10m} , in pounds (kilograms), or the volume of water, V_{10m} , in gallons (liters).

5.3.3 First-Hour Rating Test.

5.3.3.1 General. During hot water draws for water heaters with rated storage volumes greater than or equal to 20 gallons, remove water at a rate of 3.0 ± 0.25 gallons per minute (11.4 ± 0.95 liters per minute). During hot water draws for water heaters with rated storage volumes below 20 gallons, remove water at a rate of 1.5 ± 0.25 gallon per minute (5.7 ± 0.95 liters per minute). Collect the water in a container that is large enough to hold the volume removed during an individual draw and is suitable for weighing at the termination of each draw to determine the total volume of water withdrawn. As an alternative to collecting the water, a water meter may be used to directly measure the water mass or volume withdrawn during each draw.

5.3.3.2 Draw Initiation Criteria. Begin the first-hour rating test by starting a draw on the water heater. After completion of this first draw, initiate successive draws based on the following criteria. For gas-fired and oil-fired water heaters, initiate successive draws when the temperature controller acts to reduce the supply of fuel to the main burner. For electric water heaters having a single element or multiple elements that all operate simultaneously, initiate successive draws when the temperature controller acts to reduce the electrical input supplied to the element(s). For electric water heaters having two or more elements that do not operate simultaneously, initiate successive draws when the applicable temperature controller acts to reduce the electrical input to the energized element located vertically highest in the storage tank. For heat pump water heaters that do not use supplemental, resistive heating, initiate successive draws immediately after the electrical input to the compressor is reduced by the action of the water heater's temperature controller. For heat pump water heaters that use supplemental resistive heating, initiate successive draws immediately after the electrical input to the first of either the compressor or the vertically highest resistive element is reduced by the action of the applicable water heater temperature controller. This draw initiation criterion for heat pump water heaters that use supplemental resistive heating, however, shall only apply when the water located above the thermostat at cut-out is heated to within the range specified in section 2.4 of this appendix. If this criterion is not met,

then the next draw should be initiated once the heat pump compressor cuts out.

5.3.3.3 Test Sequence. Establish normal water heater operation. If the water heater is not presently operating, initiate a draw. The draw may be terminated any time after cut-in occurs. After cut-out occurs (*i.e.*, all temperature controllers are satisfied), if the water heater can have its internal tank temperatures measured, record the internal storage tank temperature at each sensor described in section 4.5 of this appendix every one minute, and determine the mean tank temperature by averaging the values from these sensors.

Initiate a draw after a maximum mean tank temperature (the maximum of the mean temperatures of the individual sensors) has been observed following a cut-out. If the water heater cannot have its internal tank temperatures measured, wait 5 minutes after cut-out. Record the time when the draw is initiated and designate it as an elapsed time of zero ($\tau^* = 0$). (The superscript $*$ is used to denote variables pertaining to the first-hour rating test). Record the outlet water temperature beginning 15 seconds after the draw is initiated and at 5-second intervals thereafter until the draw is terminated. Determine the maximum outlet temperature that occurs during this first draw and record it as $T_{\text{max},1}^*$. For the duration of this first draw and all successive draws, in addition, monitor the inlet temperature to the water heater to ensure that the required supply water temperature test condition specified in section 2.3 of this appendix is met.

Terminate the hot water draw when the outlet temperature decreases to $T_{\text{max},1}^* - 15^\circ\text{F}$ ($T_{\text{max},1}^* - 8.3^\circ\text{C}$). (Note, if the outlet temperature does not decrease to $T_{\text{max},1}^* - 15^\circ\text{F}$ ($T_{\text{max},1}^* - 8.3^\circ\text{C}$) during the draw, then hot water would be drawn continuously for the duration of the test. In this instance, the test would end when the temperature decreases to $T_{\text{max},1}^* - 15^\circ\text{F}$ ($T_{\text{max},1}^* - 8.3^\circ\text{C}$) after the electrical power and/or fuel supplied to the water heater is shut off, as described in the following paragraphs.) Record this temperature as $T_{\text{min},1}^*$. Following draw termination, determine the average outlet water temperature and the mass or volume removed during this first draw and record them as $\bar{T}_{\text{del},1}^*$ and M_{1}^* or V_{1}^* , respectively.

Initiate a second and, if applicable, successive draw(s) each time the applicable draw initiation criteria described in section 5.3.3.2 of this appendix are satisfied. As required for the first draw, record the outlet water temperature 15 seconds after initiating each draw and at 5-second intervals thereafter until the draw is terminated. Determine the maximum outlet temperature that occurs during each draw and record it as $T_{\text{max},i}^*$, where the subscript i refers to the draw number. Terminate each hot water draw when the outlet temperature decreases to $T_{\text{max},i}^* - 15^\circ\text{F}$ ($T_{\text{max},i}^* - 8.3^\circ\text{C}$). Record this temperature as $T_{\text{min},i}^*$. Calculate and record the average outlet temperature and the mass or volume removed during each draw ($\bar{T}_{\text{del},i}^*$ and M_{i}^* or V_{i}^* , respectively). Continue this sequence of draw and recovery until one hour after the start of the test, then shut off the electrical power and/or fuel supplied to the water heater.

If a draw is occurring at one hour from the start of the test, continue this draw until the outlet temperature decreases to $T^*_{\max,n} - 15\text{ }^\circ\text{F}$ ($T^*_{\max,n} - 8.3\text{ }^\circ\text{C}$), at which time the draw shall be immediately terminated. (The subscript n shall be used to denote measurements associated with the final draw.) If a draw is not occurring one hour after the start of the test, initiate a final draw at one hour, regardless of whether the criteria described in section 5.3.3.2 of this appendix are satisfied. This draw shall proceed for a minimum of 30 seconds and shall terminate when the outlet temperature first indicates a value less than or equal to

the cut-off temperature used for the previous draw ($T^*_{\min,n-1}$). If an outlet temperature greater than $T^*_{\min,n-1}$ is not measured within 30 seconds of initiation of the draw, zero additional credit shall be given towards first-hour rating (*i.e.*, $M^*_n = 0$ or $V^*_n = 0$) based on the final draw. After the final draw is terminated, calculate and record the average outlet temperature and the mass or volume removed during the final draw ($\bar{T}^*_{\text{del},n}$ and M^*_n or V^*_n , respectively).

5.4 24-Hour Simulated-Use Test.

5.4.1 Selection of Draw Pattern. The water heater will be tested under a draw profile that depends upon the first-hour

rating obtained following the test prescribed in section 5.3.3 of this appendix, or the maximum GPM rating obtained following the test prescribed in section 5.3.2 of this appendix, whichever is applicable. For water heaters that have been tested according to the first-hour rating procedure, one of four different patterns shall be applied based on the measured first-hour rating, as shown in Table I of this section. For water heater that have been tested according to the maximum GPM rating procedure, one of four different patterns shall be applied based on the maximum GPM, as shown in Table II of this section.

TABLE I—DRAW PATTERN TO BE USED BASED ON FIRST-HOUR RATING

First-hour rating greater than or equal to:	. . . and first-hour rating less than:	Draw pattern to be used in the 24-hour simulated-use test
0 gallons	18 gallons	Very-Small-Usage (Table III.1).
18 gallons	51 gallons	Low-Usage (Table III.2).
51 gallons	75 gallons	Medium-Usage (Table III.3).
75 gallons	No upper limit	High-Usage (Table III.4).

TABLE II—DRAW PATTERN TO BE USED BASED ON MAXIMUM GPM RATING

Maximum GPM rating greater than or equal to:	and maximum GPM rating less than:	Draw pattern to be used in the 24-hour simulated-use test
0 gallons/minute	1.7 gallons/minute	Very-Small-Usage (Table III.1).
1.7 gallons/minute	2.8 gallons/minute	Low-Usage (Table III.2).
2.8 gallons/minute	4 gallons/minute	Medium-Usage (Table III.3).
4 gallons/minute	No upper limit	High-Usage (Table III.4).

The draw patterns are provided in Tables III.1 through III.4 in section 5.5 of this appendix. Use the appropriate draw pattern when conducting the test sequence provided in section 5.4.2 of this appendix for water heaters with rated storage volumes greater than or equal to 2 gallons or section 5.4.3 of this appendix for water heaters with rated storage volumes less than 2 gallons.

5.4.2 Test Sequence for Water Heater With Rated Storage Volume Greater Than or Equal to 2 Gallons.

If the water heater is turned off, fill the water heater with supply water at the temperature specified in section 2.3 of this appendix and maintain supply water pressure as described in section 2.6 of this appendix. Turn on the water heater and associated heat pump unit, if present. If turned on in this fashion, the soak-in period described in section 5.2.4 of this appendix shall be implemented. If the water heater has undergone a first-hour rating test prior to conduct of the 24-hour simulated-use test, allow the water heater to fully recover after completion of that test such that the main burner, heating elements, or heat pump compressor of the water heater are no longer raising the temperature of the stored water. In all cases, the water heater shall sit idle for 1 hour prior to the start of the 24-hour test; during which time no water is drawn from the unit, and there is no energy input to the main heating elements, heat pump compressor, and/or burners.

For water heaters that can have their internal storage tank temperature measured directly, perform testing in accordance with the instructions in section 5.4.2.1 of this

appendix. For water heaters that cannot have their internal tank temperatures measured, perform testing in accordance with the instructions in section 5.4.2.2. of this appendix.

5.4.2.1 Water Heaters Which Can Have Internal Storage Tank Temperature Measured Directly.

After the 1-hour period specified in section 5.4.2 of this appendix, the 24-hour simulated-use test will begin. One minute prior to the start of the 24-hour simulated-use test, record the mean tank temperature (T_0).

At the start of the 24-hour simulated-use test, record the electrical and/or fuel measurement readings, as appropriate. Begin the 24-hour simulated-use test by withdrawing the volume specified in the appropriate table in section 5.5 of this appendix (*i.e.*, Table III.1, Table III.2, Table III.3, or Table III.4, depending on the first-hour rating or maximum GPM rating) for the first draw at the flow rate specified in the applicable table. Record the time when this first draw is initiated and assign it as the test elapsed time (τ) of zero (0). Record the average storage tank and ambient temperature every minute throughout the 24-hour simulated-use test. At the elapsed times specified in the applicable draw pattern table in section 5.5 of this appendix for a particular draw pattern, initiate additional draws pursuant to the draw pattern, removing the volume of hot water at the prescribed flow rate specified by the table. The maximum allowable deviation from the specified volume of water removed for any single draw taken at a nominal flow rate of 1.0 GPM or 1.7 GPM is ± 0.1 gallons (± 0.4

liters). The maximum allowable deviation from the specified volume of water removed for any single draw taken at a nominal flow rate of 3.0 GPM is ± 0.25 gallons (0.9 liters). The quantity of water withdrawn during the last draw shall be increased or decreased as necessary such that the total volume of water withdrawn equals the prescribed daily amount for that draw pattern ± 1.0 gallon (± 3.8 liters). If this adjustment to the volume drawn during the last draw results in no draw taking place, the test is considered invalid.

All draws during the 24-hour simulated-use test shall be made at the flow rates specified in the applicable draw pattern table in section 5.5 of this appendix, within a tolerance of ± 0.25 gallons per minute (± 0.9 liters per minute). Measurements of the inlet and outlet temperatures shall be made 15 seconds after the draw is initiated and at every subsequent 3-second interval throughout the duration of each draw. Calculate and record the mean of the hot water discharge temperature and the cold water inlet temperature for each draw $T_{\text{del},i}$ and $T_{\text{in},i}$). Determine and record the net mass or volume removed (M_i or V_i), as appropriate, after each draw.

The first recovery period is the time from the start of the 24-hour simulated-use test and continues during the temperature rise of the stored water until the first cut-out; if the cut-out occurs during a subsequent draw, the first recovery period includes the time until the draw of water from the tank stops. If, after the first cut-out occurs but during a subsequent draw, a subsequent cut-in occurs prior to the draw completion, the first

recovery period includes the time until the subsequent cut-out occurs, prior to another draw. The first recovery period may continue until a cut-out occurs when water is not being removed from the water heater or a cut-out occurs during a draw and the water heater does not cut-in prior to the end of the draw.

At the end of the first recovery period, record the maximum mean tank temperature observed after cut-out ($T_{\max,1}$). At the end of the first recovery period, record the total energy consumed by the water heater from the beginning of the test (Q_r), including all fossil fuel and/or electrical energy use, from the main heat source and auxiliary equipment including, but not limited to, burner(s), resistive element(s), compressor, fan, controls, pump, *etc.*, as applicable.

The start of the portion of the test during which the standby loss coefficient is determined depends upon whether the unit has fully recovered from the first draw cluster. If a recovery is occurring at or within five minutes after the end of the final draw in the first draw cluster, as identified in the applicable draw pattern table in section 5.5 of this appendix, then the standby period starts when a maximum mean tank temperature is observed starting five minutes after the end of the recovery period that follows that draw. If a recovery does not occur at or within five minutes after the end of the final draw in the first draw cluster, as identified in the applicable draw pattern table in section 5.5 of this appendix, then the standby period starts five minutes after the end of that draw. Determine and record the total electrical energy and/or fossil fuel consumed from the beginning of the test to the start of the standby period ($Q_{su,0}$).

In preparation for determining the energy consumed during standby, record the reading given on the electrical energy (watt-hour) meter, the gas meter, and/or the scale used to determine oil consumption, as appropriate. Record the mean tank temperature at the start of the standby period ($T_{su,0}$). At 1-minute intervals, record ambient temperature, the electric and/or fuel instrument readings, and the mean tank temperature until the next draw is initiated. The end of the standby period is when the final mean tank temperature is recorded, as described. Just prior to initiation of the next draw, record the mean tank temperature ($T_{su,r}$). If the water heater is undergoing recovery when the next draw is initiated, record the mean tank temperature ($T_{su,r}$) at the minute prior to the start of the recovery. Determine the total electrical energy and/or fossil fuel energy consumption from the beginning of the test to the end of the standby period ($Q_{su,r}$). Record the time interval between the start of the standby period and the end of the standby period ($\tau_{sby,1}$).

Following the final draw of the prescribed draw pattern and subsequent recovery, allow the water heater to remain in the standby mode until exactly 24 hours have elapsed since the start of the 24-hour simulated-use test (*i.e.*, since $\tau = 0$). During the last hour of the 24-hour simulated-use test (*i.e.*, hour 23 of the 24-hour simulated-use test), power to the main burner, heating element, or compressor shall be disabled. At 24 hours,

record the reading given by the gas meter, oil meter, and/or the electrical energy meter as appropriate. Determine the fossil fuel and/or electrical energy consumed during the entire 24-hour simulated-use test and designate the quantity as Q .

In the event that the recovery period continues from the end of the last draw of the first draw cluster until the subsequent draw, the standby period will start after the end of the first recovery period after the last draw of the 24-hour simulated-use test, when the temperature reaches the maximum mean tank temperature, though no sooner than five minutes after the end of this recovery period. The standby period shall last eight hours, so testing may extend beyond the 24-hour duration of the 24-hour simulated-use test. Determine and record the total electrical energy and/or fossil fuel consumed from the beginning of the 24-hour simulated-use test to the start of the 8-hour standby period ($Q_{su,0}$). In preparation for determining the energy consumed during standby, record the reading(s) given on the electrical energy (watt-hour) meter, the gas meter, and/or the scale used to determine oil consumption, as appropriate. Record the mean tank temperature at the start of the standby period ($T_{su,0}$). Record the mean tank temperature, the ambient temperature, and the electric and/or fuel instrument readings at 1-minute intervals until the end of the 8-hour period. Record the mean tank temperature at the end of the 8-hour standby period ($T_{su,r}$). If the water heater is undergoing recovery at the end of the standby period, record the mean tank temperature ($T_{su,r}$) at the minute prior to the start of the recovery, which will mark the end of the standby period. Determine the total electrical energy and/or fossil fuel energy consumption from the beginning of the test to the end of the standby period ($Q_{su,r}$). Record the time interval between the start of the standby period and the end of the standby period as $\tau_{sby,1}$. Record the average ambient temperature from the start of the standby period to the end of the standby period ($T_{a,sby,1}$). Record the average mean tank temperature from the start of the standby period to the end of the standby period ($T_{t,sby,1}$).

If the standby period occurred at the end of the first recovery period after the last draw of the 24-hour simulated-use test, allow the water heater to remain in the standby mode until exactly 24 hours have elapsed since the start of the 24-hour simulated-use test (*i.e.*, since $\tau = 0$) or the end of the standby period, whichever is longer. At 24 hours, record the mean tank temperature (T_{24}) and the reading given by the gas meter, oil meter, and/or the electrical energy meter as appropriate. If the water heater is undergoing a recovery at 24 hours, record the reading given by the gas meter, oil meter, and/or electrical energy meter, as appropriate, and the mean tank temperature (T_{24}) at the minute prior to the start of the recovery. Determine the fossil fuel and/or electrical energy consumed during the 24 hours and designate the quantity as Q .

Record the time during which water is not being withdrawn from the water heater during the entire 24-hour period ($\tau_{sby,2}$). When the standby period occurs after the last draw of the 24-hour simulated-use test, the

test may extend past hour 24. When this occurs, the measurements taken after hour 24 apply only to the calculations of the standby loss coefficient. All other measurements during the time between hour 23 and hour 24 remain the same.

5.4.2.2 Water Heaters Which Cannot Have Internal Storage Tank Temperature Measured Directly.

After the water heater has undergone a 1-hour idle period (as described in section 5.4.2 of this appendix), deactivate the burner, compressor, or heating element(s).

Remove water from the storage tank by performing a continuous draw at the flow rate specified for the first draw of applicable draw pattern for the 24-hour simulated use test in section 5.5 of this appendix within a tolerance of ± 0.25 gallons per minute (± 0.9 liters per minute). While removing the hot water, measure the inlet and outlet temperature after initiating the draw at 3-second intervals. Remove water until the outlet water temperature is within $\pm 2^\circ\text{F}$ ($\pm 1.1^\circ\text{C}$) of the inlet water temperature for 15 consecutive seconds. Determine the mean tank temperature using section 6.3.77 of this appendix and assign this value of \bar{T}_{st} for \bar{T}_0 , $\bar{T}_{\max,1}$, and $\bar{T}_{su,0}$.

After completing the draw, reactivate the burner, compressor, or heating element(s) and allow the unit to fully recover such that the main burner, heating elements, or heat pump compressor is no longer raising the temperature of the stored water. Let the water heater sit idle again for 1 hour prior to beginning the 24-hour test, during which time no water shall be drawn from the unit, and there shall be no energy input to the main heating elements. After the 1-hour period, the 24-hour simulated-use test will begin.

At the start of the 24-hour simulated-use test, record the electrical and/or fuel measurement readings, as appropriate. Begin the 24-hour simulated-use test by withdrawing the volume specified in the appropriate table in section 5.5 of this appendix (*i.e.*, Table III.1, Table III.2, Table III.3, or Table III.4, depending on the first-hour rating or maximum GPM rating) for the first draw at the flow rate specified in the applicable table. Record the time when this first draw is initiated and assign it as the test elapsed time (τ) of zero (0). Record the average ambient temperature every minute throughout the 24-hour simulated-use test. At the elapsed times specified in the applicable draw pattern table in section 5.5 of this appendix for a particular draw pattern, initiate additional draws pursuant to the draw pattern, removing the volume of hot water at the prescribed flow rate specified by the table. The maximum allowable deviation from the specified volume of water removed for any single draw taken at a nominal flow rate of 1.0 GPM or 1.7 GPM is ± 0.1 gallons (± 0.4 liters). The maximum allowable deviation from the specified volume of water removed for any single draw taken at a nominal flow rate of 3.0 GPM is ± 0.25 gallons (0.9 liters). The quantity of water withdrawn during the last draw shall be increased or decreased as necessary such that the total volume of water withdrawn equals the prescribed daily amount for that draw

pattern ± 1.0 gallon (± 3.8 liters). If this adjustment to the volume drawn during the last draw results in no draw taking place, the test is considered invalid.

All draws during the 24-hour simulated-use test shall be made at the flow rates specified in the applicable draw pattern table in section 5.5 of this appendix, within a tolerance of ±0.25 gallons per minute (±0.9 liters per minute). Measurements of the inlet and outlet temperatures shall be made 15 seconds after the draw is initiated and at every subsequent 3-second interval throughout the duration of each draw. Calculate and record the mean of the hot water discharge temperature and the cold water inlet temperature for each draw $T_{del,i}$ and $T_{in,i}$. Determine and record the net mass or volume removed (M_i or V_i), as appropriate, after each draw.

The first recovery period is the time from the start of the 24-hour simulated-use test and continues until the first cut-out; if the cut-out occurs during a subsequent draw, the first recovery period includes the time until the draw of water from the tank stops. If, after the first cut-out occurs but during a subsequent draw, a subsequent cut-in occurs prior to the draw completion, the first recovery period includes the time until the subsequent cut-out occurs, prior to another draw. The first recovery period may continue until a cut-out occurs when water is not being removed from the water heater or a cut-out occurs during a draw and the water heater does not cut-in prior to the end of the draw.

At the end of the first recovery period, record the total energy consumed by the water heater from the beginning of the test (Q_c), including all fossil fuel and/or electrical energy use, from the main heat source and auxiliary equipment including, but not limited to, burner(s), resistive elements(s), compressor, fan, controls, pump, etc., as applicable.

The standby period begins at five minutes after the first time a recovery ends following last draw of the simulated-use test and shall continue for 8 hours. At the end of the 8-hour standby period, record the total amount of time elapsed since the start of the 24-hour simulated-use test (*i.e.*, since $\tau = 0$).

Determine and record the total electrical energy and/or fossil fuel consumed from the beginning of the 24-hour simulated-use test to the start of the 8-hour standby period ($Q_{su,0}$). In preparation for determining the energy consumed during standby, record the reading(s) given on the electrical energy (watt-hour) meter, the gas meter, and/or the scale used to determine oil consumption, as appropriate. Record the ambient temperature

and the electric and/or fuel instrument readings at 1-minute intervals until the end of the 8-hour period. At the 8-hour mark, deactivate the water heater before drawing water from the tank. Remove water from the storage tank by performing a continuous draw at the flow rate specified for the first draw of applicable draw pattern for the 24-hour simulated use test in section 5.5 of this appendix within a tolerance of ±0.25 gallons per minute (±0.9 liters per minute). While removing the hot water, measure the inlet and outlet temperature after initiating the draw at 3-second intervals. Remove water until the outlet water temperature is within ±2 °F (±1.1 °C) of the inlet water temperature for 15 consecutive seconds. Determine the mean tank temperature using section 6.3.77 of this appendix and assign this value of T_{st} for $T_{su,f}$ and T_{24} .

Determine the total electrical energy and/or fossil fuel energy consumption from the beginning of the test to the end of the standby period ($Q_{su,f}$). Record the time interval between the start of the standby period and the end of the standby period as $\tau_{stby,1}$. Record the average ambient temperature from the start of the standby period to the end of the standby period ($T_{a,stby,1}$). The average mean tank temperature from the start of the standby period to the end of the standby period ($T_{su,0}$) shall be the average of $T_{su,0}$ and $T_{su,f}$.

5.4.3 Test Sequence for Water Heaters With Rated Storage Volume Less Than 2 Gallons.

Establish normal operation with the discharge water temperature at 125 °F ± 5 °F (51.7 °C ± 2.8 °C) and set the flow rate as determined in section 5.2 of this appendix. Prior to commencement of the 24-hour simulated-use test, the unit shall remain in an idle state in which controls are active but no water is drawn through the unit for a period of one hour. With no draw occurring, record the reading given by the gas meter and/or the electrical energy meter as appropriate. Begin the 24-hour simulated-use test by withdrawing the volume specified in Tables III.1 through III.4 of section 5.5 of this appendix for the first draw at the flow rate specified. Record the time when this first draw is initiated and designate it as an elapsed time, τ , of 0. At the elapsed times specified in Tables III.1 through III.4 for a particular draw pattern, initiate additional draws, removing the volume of hot water at the prescribed flow rate specified in Tables III.1 through III.4. The maximum allowable deviation from the specified volume of water removed for any single draw taken at a nominal flow rate less than or equal to 1.7 GPM (6.4 L/min) is ±0.1 gallons (±0.4 liters).

The maximum allowable deviation from the specified volume of water removed for any single draw taken at a nominal flow rate of 3.0 GPM (11.4 L/min) is ±0.25 gallons (0.9 liters). The quantity of water drawn during the final draw shall be increased or decreased as necessary such that the total volume of water withdrawn equals the prescribed daily amount for that draw pattern ±1.0 gallon (±3.8 liters). If this adjustment to the volume drawn in the last draw results in no draw taking place, the test is considered invalid.

All draws during the 24-hour simulated-use test shall be made at the flow rates specified in the applicable draw pattern table in section 5.5 of this appendix within a tolerance of ±0.25 gallons per minute (±0.9 liters per minute) unless the unit being tested is flow-activated and has a rated Max GPM of less than 1 gallon per minute, in which case the tolerance shall be ±25% of the rated Max GPM. Measurements of the inlet and outlet water temperatures shall be made 15 seconds after the draw is initiated and at every 3-second interval thereafter throughout the duration of the draw. Calculate the mean of the hot water discharge temperature and the cold-water inlet temperature for each draw. Record the mass of the withdrawn water or the water meter reading, as appropriate, after each draw. At the end of the first recovery period following the first draw, determine and record the fossil fuel and/or electrical energy consumed, Q_r . Following the final draw and subsequent recovery, allow the water heater to remain in the standby mode until exactly 24 hours have elapsed since the start of the test (*i.e.*, since $\tau = 0$). At 24 hours, record the reading given by the gas meter, oil meter, and/or the electrical energy meter, as appropriate. Determine the fossil fuel and/or electrical energy consumed during the entire 24-hour simulated-use test and designate the quantity as Q_c .

5.5 Draw Patterns.

The draw patterns to be imposed during 24-hour simulated-use tests are provided in Tables III.1 through III.4. Subject each water heater under test to one of these draw patterns based on its first-hour rating or maximum GPM rating, as discussed in section 5.4.1 of this appendix. Each draw pattern specifies the elapsed time in hours and minutes during the 24-hour test when a draw is to commence, the total volume of water in gallons (liters) that is to be removed during each draw, and the flow rate at which each draw is to be taken, in gallons (liters) per minute.

TABLE III.1—VERY-SMALL-USAGE DRAW PATTERN

Draw No.	Time during test** [hh:mm]	Volume [gallons (L)]	Flow rate*** [GPM (L/min)]
1*	0:00	2.0 (7.6)	1 (3.8)
2*	1:00	1.0 (3.8)	1 (3.8)
3*	1:05	0.5 (1.9)	1 (3.8)
4*	1:10	0.5 (1.9)	1 (3.8)
5*	1:15	0.5 (1.9)	1 (3.8)
6	8:00	1.0 (3.8)	1 (3.8)
7	8:15	2.0 (7.6)	1 (3.8)

TABLE III.1—VERY-SMALL-USAGE DRAW PATTERN—Continued

Draw No.	Time during test** [hh:mm]	Volume [gallons (L)]	Flow rate*** [GPM (L/min)]
8	9:00	1.5 (5.7)	1 (3.8)
9	9:15	1.0 (3.8)	1 (3.8)

Total Volume Drawn Per Day: 10 gallons (38 L)

*Denotes draws in first draw cluster.

**If a draw extends to the start of the subsequent draw, then the subsequent draw shall start when the required volume of the previous draw has been delivered.

***Should the water heater have a maximum GPM rating less than 1 GPM (3.8 L/min), then all draws shall be implemented at a flow rate equal to the rated maximum GPM.

TABLE III.2—LOW-USAGE DRAW PATTERN

Draw No.	Time during test [hh:mm]	Volume [gallons (L)]	Flow rate [GPM (L/min)]
1*	0:00	15.0 (56.8)	1.7 (6.4)
2*	0:30	2.0 (7.6)	1 (3.8)
3*	1:00	1.0 (3.8)	1 (3.8)
4	10:30	6.0 (22.7)	1.7 (6.4)
5	11:30	4.0 (15.1)	1.7 (6.4)
6	12:00	1.0 (3.8)	1 (3.8)
7	12:45	1.0 (3.8)	1 (3.8)
8	12:50	1.0 (3.8)	1 (3.8)
9	16:15	2.0 (7.6)	1 (3.8)
10	16:45	2.0 (7.6)	1.7 (6.4)
11	17:00	3.0 (11.4)	1.7 (6.4)

Total Volume Drawn Per Day: 38 gallons (144 L)

*Denotes draws in first draw cluster.

TABLE III.3—MEDIUM-USAGE DRAW PATTERN

Draw No.	Time during test [hh:mm]	Volume [gallons (L)]	Flow Rate [GPM (L/min)]
1*	0:00	15.0 (56.8)	1.7 (6.4)
2*	0:30	2.0 (7.6)	1 (3.8)
3*	1:40	9.0 (34.1)	1.7 (6.4)
4	10:30	9.0 (34.1)	1.7 (6.4)
5	11:30	5.0 (18.9)	1.7 (6.4)
6	12:00	1.0 (3.8)	1 (3.8)
7	12:45	1.0 (3.8)	1 (3.8)
8	12:50	1.0 (3.8)	1 (3.8)
9	16:00	1.0 (3.8)	1 (3.8)
10	16:15	2.0 (7.6)	1 (3.8)
11	16:45	2.0 (7.6)	1.7 (6.4)
12	17:00	7.0 (26.5)	1.7 (6.4)

Total Volume Drawn Per Day: 55 gallons (208 L)

*Denotes draws in first draw cluster.

TABLE III.4—HIGH-USAGE DRAW PATTERN

Draw No.	Time during test [hh:mm]	Volume [gallons (L)]	Flow rate [GPM (L/min)]
1*	0:00	27.0 (102)	3 (11.4)
2*	0:30	2.0 (7.6)	1 (3.8)
3*	0:40	1.0 (3.8)	1 (3.8)
4*	1:40	9.0 (34.1)	1.7 (6.4)
5	10:30	15.0 (56.8)	3 (11.4)
6	11:30	5.0 (18.9)	1.7 (6.4)
7	12:00	1.0 (3.8)	1 (3.8)
8	12:45	1.0 (3.8)	1 (3.8)
9	12:50	1.0 (3.8)	1 (3.8)
10	16:00	2.0 (7.6)	1 (3.8)

TABLE III.4—HIGH-USAGE DRAW PATTERN—Continued

Draw No.	Time during test [hh:mm]	Volume [gallons (L)]	Flow rate [GPM (L/min)]
11	16:15	2.0 (7.6)	1 (3.8)
12	16:30	2.0 (7.6)	1.7 (6.4)
13	16:45	2.0 (7.6)	1.7 (6.4)
14	17:00	14.0 (53.0)	3 (11.4)

Total Volume Drawn Per Day: 84 gallons (318 L)

* Denotes draws in first draw cluster.

5.6 *Optional Tests (Heat Pump-Type Water Heaters)*. Optional testing may be conducted on heat pump-type water heaters to determine E_x. If optional testing is performed, conduct the additional 24-hour simulated use test(s) at one or multiple of the test conditions specified in section 2.8 of this appendix. Prior to conducting a 24-hour simulated use test at an optional condition, confirm the air and water conditions specified in section 2.8 are met and re-set the outlet discharge temperature in accordance with section 5.2.2 of this appendix. Perform the optional 24-hour simulated use test(s) in accordance with section 5.4 of this appendix using the same draw pattern used for the determination of UEF.

6. Computations.

6.1 *First-Hour Rating Computation*. For the case in which the final draw is initiated at or prior to one hour from the start of the test, the first-hour rating, F_{hr}, shall be computed using,

$$F_{hr} = \sum_{i=1}^n V_{del,i}^*$$

Where:

n = the number of draws that are completed during the first-hour rating test.

V*_{del,i} = the volume of water removed during the ith draw of the first-hour rating test, gal (L) or, if the mass of water removed is being measured,

$$V_{del,i}^* = \frac{M_{del,i}^*}{\rho_{del,i}}$$

Where:

M*_{del,i} = the mass of water removed during the ith draw of the first-hour rating test, lb (kg).

ρ_{del,i} = the density of water removed, evaluated at the average outlet water temperature measured during the ith draw of the first-hour rating test, (T*_{del,i}), lb/gal (kg/L).

or, if the volume of the water entering the water heater is being measured,

$$V_{del,i}^* = V_{in,i}^* \frac{\rho_{in,i}}{\rho_{del,i}}$$

Where:

$$F_{hr} = V_{del,n}^* \left(\frac{\bar{T}_{del,n}^* - \bar{T}_{min,n-1}^*}{\bar{T}_{del,n-1}^* - \bar{T}_{min,n-1}^*} \right) + \sum_{i=1}^{n-1} V_{del,i}^*$$

where n and V*_{del,i} are the same quantities as defined above, and

V*_{del,n} = the volume of water removed during the nth (final) draw of the first-hour rating test, gal (L).

T*_{del,n-1} = the average water outlet temperature measured during the (n-1)th draw of the first-hour rating test, °F (°C).

T*_{del,n} = the average water outlet temperature measured during the nth (final) draw of the first-hour rating test, °F (°C).

T*_{min,n-1} = the minimum water outlet temperature measured during the (n-1)th draw of the first-hour rating test, °F (°C).

6.2 *Maximum GPM (L/min) Rating Computation*. Compute the maximum GPM (L/min) rating, F_{max}, as:

$$F_{max} = \frac{V_{del,10m}(\bar{T}_{del} - \bar{T}_{in})}{10(125^{\circ}F - 58^{\circ}F)}$$

or,

$$F_{max} = \frac{V_{del,10m}(\bar{T}_{del} - \bar{T}_{in})}{10(51.7^{\circ}C - 14.4^{\circ}C)}$$

Where:

V_{del,10m} = the volume of water removed during the maximum GPM (L/min) rating test, gal (L).

T_{del} = the average delivery temperature, °F (°C).

T_{in} = the average inlet temperature, °F (°C).

10 = the number of minutes in the maximum GPM (L/min) rating test, min.

or, if the mass of water removed is measured,

V*_{in,i} = the volume of water entering the water heater during the ith draw of the first-hour rating test, gal (L).

ρ_{in,i} = the density of water entering the water heater, evaluated at the average inlet water temperature measured during the ith draw of the first-hour rating test, (T*_{in,i}), lb/gal (kg/L).

or, if the mass of water entering the water heater is being measured,

$$V_{del,i}^* = \frac{M_{in,i}^*}{\rho_{del,i}}$$

Where:

M*_{in,i} = the mass of water entering the water heater during the ith draw of the first-hour rating test, lb (kg).

For the case in which a draw is not in progress at one hour from the start of the test and a final draw is imposed at the elapsed time of one hour, the first-hour rating shall be calculated using,

$$V_{del,10m} = \frac{M_{del,10m}}{\rho_{del}}$$

Where:

M_{del,10m} = the mass of water removed during the maximum GPM (L/min) rating test, lb (kg).

ρ_{del} = the density of water removed, evaluated at the average delivery water temperature of the maximum GPM (L/min) rating test (T_{del}), lb/gal (kg/L).

or, if the volume of water entering the water heater is measured,

$$V_{del,10m} = V_{in,10m} \frac{\rho_{in}}{\rho_{del}}$$

Where:

V_{in,10m} = the volume of water entering the water heater during the maximum GPM (L/min) rating test, gal (L).

ρ_{in} = the density of water entering the water heater, evaluated at the average inlet

water temperature of the maximum GPM (L/min) rating test (\bar{T}_{del}), lb/gal (kg/L).
or, if the mass of water entering the water heater is measured,

$$V_{del,10m} = \frac{M_{in,10m}}{\rho_{del}}$$

Where:

$M_{in,10m}$ = the mass of water entering the water heater during the maximum GPM (L/min) rating test, lb (kg).

6.3 Computations for Water Heaters with a Rated Storage Volume Greater Than or Equal to 2 Gallons and Circulating Water Heaters.

6.3.1 Storage Tank Capacity. The storage tank capacity, V_{st} , is computed as follows:

$$V_{st} = \frac{(W_f - W_t)}{\rho}$$

Where:

V_{st} = the storage capacity of the water heater, or, for circulating water heaters, the storage capacity of the separate storage tank used in accordance with section 4.10, gal (L).

W_f = the weight of the storage tank when completely filled with water, lb (kg).

W_t = the (tare) weight of the storage tank when completely empty, lb (kg).

ρ = the density of water used to fill the tank measured at the temperature of the water, lb/gal (kg/L).

6.3.1.1 Effective Storage Volume. The effective storage tank capacity, V_{eff} , is computed as follows:

For water heaters requiring a separate storage tank, V_{eff} is the storage tank capacity of the separate storage tank as determined per section 6.3.1.

For all other water heaters:

$$V_{eff} = k_v V_{st}$$

Where:

V_{st} = as defined in section 6.3.1 and

k_v = a dimensionless volume scaling factor determined as follows:

If the first recovery period extends into the second draw of the 24-hour simulated use test, and

If $\bar{T}_0 > (\bar{T}_{del,1} + 5^\circ\text{F})$ and $\bar{T}_0 \geq 130^\circ\text{F}$,
(if $\bar{T}_0 > (\bar{T}_{del,1} + 2.8^\circ\text{C})$ and $\bar{T}_0 \geq 54.4^\circ\text{C}$),

$$k_v = \frac{\rho(\bar{T}_0) \times C_p(\bar{T}_0) \times (\bar{T}_0 - 67.5^\circ\text{F})}{\rho(125^\circ\text{F}) \times C_p(125^\circ\text{F}) \times (125^\circ\text{F} - 67.5^\circ\text{F})}$$

$$(k_v = \frac{\rho(\bar{T}_0) \times C_p(\bar{T}_0) \times (\bar{T}_0 - 19.7^\circ\text{C})}{\rho(51.7^\circ\text{C}) \times C_p(51.7^\circ\text{C}) \times (51.7^\circ\text{C} - 19.7^\circ\text{C})});$$

If the first recovery period does not extend into the second draw of the 24-hour simulated use test, and

If $\bar{T}_{max,1} > (\bar{T}_{del,2} + 5^\circ\text{F})$ and $\bar{T}_{max,1} \geq 130^\circ\text{F}$,

(if $\bar{T}_{max,1} > (\bar{T}_{del,2} + 2.8^\circ\text{C})$ and $\bar{T}_{max,1} \geq 54.4^\circ\text{C}$),

$$k_v = \frac{\rho(\bar{T}_{max,1}) \times C_p(\bar{T}_{max,1}) \times (\bar{T}_{max,1} - 67.5^\circ\text{F})}{\rho(125^\circ\text{F}) \times C_p(125^\circ\text{F}) \times (125^\circ\text{F} - 67.5^\circ\text{F})}$$

$$(k_v = \frac{\rho(\bar{T}_{max,1}) \times C_p(\bar{T}_{max,1}) \times (\bar{T}_{max,1} - 19.7^\circ\text{C})}{\rho(51.7^\circ\text{C}) \times C_p(51.7^\circ\text{C}) \times (51.7^\circ\text{C} - 19.7^\circ\text{C})});$$

Otherwise, $k_v = 1$.

Where:

\bar{T}_0 = the mean tank temperature at the beginning of the 24-hour simulated-use test, $^\circ\text{F}$ ($^\circ\text{C}$).

$\bar{T}_{del,1}$ = the average outlet water temperature during the first draw of the 24-hour simulated-use test, $^\circ\text{F}$ ($^\circ\text{C}$).

$\rho(\bar{T}_0)$ = the density of the stored hot water evaluated at the mean tank temperature at the beginning of the 24-hour simulated-use test (\bar{T}_0), lb/gal (kg/L).

$C_p(\bar{T}_0)$ = the specific heat of the stored hot water, evaluated at \bar{T}_0 , Btu/(lb \cdot °F) (kJ/(kg \cdot °C)).

$\bar{T}_{max,1}$ = the maximum measured mean tank temperature after cut-out following the first draw of the 24-hour simulated-use test, $^\circ\text{F}$ ($^\circ\text{C}$).

$\bar{T}_{del,2}$ = the average outlet water temperature during the second draw of the 24-hour simulated-use test, $^\circ\text{F}$ ($^\circ\text{C}$).

$\rho(\bar{T}_{max,1})$ = the density of the stored hot water evaluated at the maximum measured mean tank temperature after cut-out following the first draw of the 24-hour simulated-use test ($\bar{T}_{max,1}$), lb/gal (kg/L).

$C_p(\bar{T}_{max,1})$ = the specific heat of the stored hot water, evaluated at $\bar{T}_{max,1}$, Btu/(lb \cdot °F) (kJ/(kg \cdot °C)).

$\rho(125^\circ\text{F})$ = the density of the stored hot water at 125 °F, lb/gal (kg/L).

$C_p(125^\circ\text{F})$ = the specific heat of the stored hot water at 125 °F, Btu/(lb \cdot °F) (kJ/(kg \cdot °C)).

125 °F (51.7 °C) = the nominal maximum mean tank temperature for a storage tank that does not utilize a mixing valve to achieve a 125 °F delivery temperature.
67.5 °F (19.7 °C) = the nominal average ambient air temperature.

6.3.2 Mass of Water Removed. Determine the mass of water removed during each draw of the 24-hour simulated-use test ($M_{del,i}$) as:

If the mass of water removed is measured, use the measured value, or, if the volume of water removed is being measured,

$$M_{del,i} = V_{del,i} * \rho_{del,i}$$

Where:

$V_{del,i}$ = volume of water removed during the i th draw of the 24-hour simulated-use test, gal (L).

$\rho_{del,i}$ = density of the water removed, evaluated at the average outlet water

temperature measured during the i th draw of the 24-hour simulated-use test, ($\bar{T}_{del,i}$), lb/gal (kg/L).

or, if the volume of water entering the water heater is measured,

$$M_{del,i} = V_{in,i} * \rho_{in,i}$$

Where:

$V_{in,i}$ = volume of water entering the water heater during draw i th draw of the 24-hour simulated-use test, gal (L).

$\rho_{in,i}$ = density of the water entering the water heater, evaluated at the average inlet water temperature measured during the i th draw of the 24-hour simulated-use test, ($\bar{T}_{in,i}$), lb/gal (kg/L).

or, if the mass of water entering the water heater is measured,

$$M_{del,i} = M_{in,i}$$

Where:

$M_{in,i}$ = mass of water entering the water heater during draw i th draw of the 24-hour simulated-use test, lb (kg).

6.3.3 Recovery Efficiency. The recovery efficiency for gas, oil, and heat pump water heaters with a rated storage volume greater than or equal to 2 gallons, η_r , is computed as:

$$\eta_r = \frac{V_{st} \rho_1 C_{p1} (\bar{T}_{max,1} - \bar{T}_0)}{Q_r} + \sum_{i=1}^{N_r} \frac{M_{del,i} C_{pi} (\bar{T}_{del,i} - \bar{T}_{in,i})}{Q_r}$$

Where:

V_{st} = as defined in section 6.3.1 of this appendix.

ρ_1 = density of stored hot water evaluated at $(\bar{T}_{max,1} + \bar{T}_0)/2$, lb/gal (kg/L).

C_{p1} = specific heat of the stored hot water, evaluated at $(\bar{T}_{max,1} + \bar{T}_0)/2$, Btu/(lb·°F) (kJ/(kg·°C)).

$\bar{T}_{max,1}$ = maximum mean tank temperature recorded after the first recovery period as defined in section 5.4.2 of this appendix, °F (°C).

\bar{T}_0 = mean tank temperature recorded at the beginning of the 24-hour simulated-use test as determined in section 5.4.2 of this appendix, °F (°C).

Q_r = the total energy used by the water heater during the first recovery period as defined in section 5.4.2 of this appendix, including auxiliary energy such as pilot lights, pumps, fans, etc., Btu (kJ). (Electrical auxiliary energy shall be converted to thermal energy using the following conversion: 1 kWh = 3412 Btu).

N_r = number of draws from the start of the 24-hour simulated-use test to the end of the first recovery period as described in section 5.4.2.

$M_{del,i}$ = mass of water removed as calculated in section 6.3.2 of this appendix during the i th draw of the first recovery period as described in section 5.4.2, lb (kg).

C_{pi} = specific heat of the withdrawn water during the i th draw of the first recovery period as described in section 5.4.2, evaluated at $(\bar{T}_{del,i} + \bar{T}_{in,i})/2$, Btu/(lb·°F) (kJ/(kg·°C)).

$\bar{T}_{del,i}$ = average water outlet temperature measured during the i th draw of the first recovery period as described in section 5.4.2, °F (°C).

$\bar{T}_{in,i}$ = average water inlet temperature measured during the i th draw of the first recovery period as described in section 5.4.2, °F (°C).

The recovery efficiency for electric water heaters with immersed heating elements, not including heat pump water heaters with

immersed heating elements, is assumed to be 98 percent.

6.3.4 *Hourly Standby Losses.* The energy consumed as part of the standby loss test of the 24-hour simulated-use test, Q_{stby} , is computed as:

$$Q_{stby} = Q_{su,f} - Q_{su,0}$$

Where:

$Q_{su,0}$ = cumulative energy consumption, including all fossil fuel and electrical energy use, of the water heater from the start of the 24-hour simulated-use test to the start of the standby period as determined in section 5.4.2 of this appendix, Btu (kJ).

$Q_{su,f}$ = cumulative energy consumption, including all fossil fuel and electrical energy use, of the water heater from the start of the 24-hour simulated-use test to the end of the standby period as determined in section 5.4.2 of this appendix, Btu (kJ).

The hourly standby energy losses are computed as:

$$Q_{hr} = \frac{Q_{stby} - \frac{V_{st} \rho C_p (\bar{T}_{su,f} - \bar{T}_{su,0})}{\eta_r}}{\tau_{stby,1}}$$

Where:

Q_{hr} = the hourly standby energy losses of the water heater, Btu/h (kJ/h).

V_{st} = as defined in section 6.3.1 of this appendix.

ρ = density of the stored hot water, evaluated at $(\bar{T}_{su,f} + \bar{T}_{su,0})/2$, lb/gal (kg/L).

C_p = specific heat of the stored water, evaluated at $(\bar{T}_{su,f} + \bar{T}_{su,0})/2$, Btu/(lb·°F), (kJ/(kg·K)).

$\bar{T}_{su,f}$ = the mean tank temperature measured at the end of the standby period as determined in section 5.4.2 of this appendix, °F (°C).

$\bar{T}_{su,0}$ = the maximum mean tank temperature measured at the beginning of the standby

period as determined in section 5.4.2 of this appendix, °F (°C).

η_r = as defined in section 6.3.3 of this appendix.

$\tau_{stby,1}$ = elapsed time between the start and end of the standby period as determined in section 5.4.2 of this appendix, h.

The standby heat loss coefficient for the tank is computed as:

$$UA = \frac{Q_{hr}}{\bar{T}_{t,stby,1} - \bar{T}_{a,stby,1}}$$

Where:

UA = standby heat loss coefficient of the storage tank, Btu/(h·°F), (kJ/(h·°C)).

$\bar{T}_{t,stby,1}$ = overall average mean tank temperature between the start and end of the standby period as determined in section 5.4.2 of this appendix, °F (°C).

$\bar{T}_{a,stby,1}$ = overall average ambient temperature between the start and end of the standby period as determined in section 5.4.2 of this appendix, °F (°C).

6.3.5 *Daily Water Heating Energy*

Consumption. The total energy used by the water heater during the 24-hour simulated-use test (Q) is as measured in section 5.4.2 of this appendix, or,

$Q = Q_f + Q_e$ = total energy used by the water heater during the 24-hour simulated-use

test, including auxiliary energy such as pilot lights, pumps, fans, etc., Btu (kJ).

Q_f = total fossil fuel energy used by the water heater during the 24-hour simulated-use test, Btu (kJ).

Q_e = total electrical energy used during the 24-hour simulated-use test, Btu (kJ). (Electrical energy shall be converted to thermal energy using the following conversion: 1 kWh = 3412 Btu.)

The daily water heating energy consumption, Q_d , is computed as:

$$Q_d = Q - \frac{V_{st} \rho C_p (\bar{T}_{24} - \bar{T}_0)}{\eta_r}$$

Where:

V_{st} = as defined in section 6.3.1 of this appendix.

ρ = density of the stored hot water, evaluated at $(\bar{T}_{24} + \bar{T}_0)/2$, lb/gal (kg/L).

C_p = specific heat of the stored water, evaluated at $(\bar{T}_{24} + \bar{T}_0)/2$, Btu/(lb·°F), (kJ/(kg·K)).

\bar{T}_{24} = mean tank temperature at the end of the 24-hour simulated-use test as determined in section 5.4.2 of this appendix, °F (°C).

\bar{T}_0 = mean tank temperature recorded at the beginning of the 24-hour simulated-use test as determined in section 5.4.2 of this appendix, °F (°C).

η_r = as defined in section 6.3.3 of this appendix.

6.3.6 *Adjusted Daily Water Heating Energy Consumption.* The adjusted daily water

heating energy consumption, Q_{da} , takes into account that the ambient temperature may differ from the nominal value of 67.5 °F (19.7 °C) due to the allowable variation in surrounding ambient temperature of 65 °F (18.3 °C) to 70 °C (21.1 °C). The adjusted daily water heating energy consumption is computed as:

$$Q_{da} = Q_d - (67.5^{\circ}\text{C} - \bar{T}_{a,\text{stby},2}) UA \tau_{\text{stby},2}$$

or,

$$Q_{da} = Q_d - (19.7^{\circ}\text{C} - \bar{T}_{a,\text{stby},2}) UA \tau_{\text{stby},2}$$

Where:

Q_{da} = the adjusted daily water heating energy consumption, Btu (kJ).
 Q_d = as defined in section 6.3.4 of this appendix.
 $\bar{T}_{a,\text{stby},2}$ = the average ambient temperature during the total standby portion, $\tau_{\text{stby},2}$, of the 24-hour simulated-use test, °F (°C).
 UA = as defined in section 6.3.4 of this appendix.
 $\tau_{\text{stby},2}$ = the number of hours during the 24-hour simulated-use test when water is

not being withdrawn from the water heater.

A modification is also needed to take into account that the temperature difference between the outlet water temperature and supply water temperature may not be equivalent to the nominal value of 67 °F (125 °F–58 °F) or 37.3 °C (51.7 °C–14.4 °C). The following equations adjust the experimental data to a nominal 67 °F (37.3 °C) temperature rise.

The energy used to heat water, Btu/day (kJ/day), may be computed as:

$$Q_{HW} = \sum_{i=1}^N \frac{M_{del,i} C_{pi} (\bar{T}_{del,i} - \bar{T}_{in,i})}{\eta_r}$$

Where:

N = total number of draws in the 24-hour simulated-use test.
 $M_{del,i}$ = the mass of water removed during the i th draw ($i = 1$ to N) as calculated in section 6.3.2 of this appendix, lb (kg).
 C_{pi} = the specific heat of the water withdrawn during the i th draw of the 24-hour

simulated-use test, evaluated at $(\bar{T}_{del,i} + \bar{T}_{in,i})/2$, Btu/(lb · °F) (kJ/(kg · °C)).
 $\bar{T}_{del,i}$ = the average water outlet temperature measured during the i th draw ($i = 1$ to N), °F (°C).
 $\bar{T}_{in,i}$ = the average water inlet temperature measured during the i th draw ($i = 1$ to N), °F (°C).

η_r = as defined in section 6.3.3 of this appendix.

The energy required to heat the same quantity of water over a 67 °F (37.3 °C) temperature rise, Btu/day (kJ/day), is:

$$Q_{HW,67^{\circ}\text{F}} = \sum_{i=1}^N \frac{M_{del,i} C_{pi} (125^{\circ}\text{F} - 58^{\circ}\text{F})}{\eta_r}$$

or,

$$Q_{HW,37.3^{\circ}\text{C}} = \sum_{i=1}^N \frac{M_{del,i} C_{pi} (51.7^{\circ}\text{C} - 14.4^{\circ}\text{C})}{\eta_r}$$

The difference between these two values is:

$$Q_{HWD} = Q_{HW,67^{\circ}\text{F}} - Q_{HW}$$

or,

$$Q_{HWD} = Q_{HW,37.3^{\circ}\text{C}} - Q_{HW}$$

This difference (Q_{HWD}) must be added to the adjusted daily water heating energy consumption value. Thus, the daily energy

consumption value, which takes into account that the ambient temperature may not be 67.5 °F (19.7 °C) and that the temperature rise across the storage tank may not be 67 °F (37.3 °C) is:

$$Q_{dm} = Q_{da} - Q_{HWD}$$

6.3.7 Estimated Mean Tank Temperature for Water Heaters with Rated Storage Volumes Greater Than or Equal to 2 Gallons.

If testing is conducted in accordance with section 5.4.2.2 of this appendix, calculate the mean tank temperature immediately prior to the internal tank temperature determination draw using the following equation:

$$\bar{T}_{st} = T_p - \frac{v_{out,p}}{V_{st}} \times \tau_p (\bar{T}_{in,p} - \bar{T}_{out,p})$$

Where:

\bar{T}_{st} = the estimated average internal storage tank temperature, °F (°C).
 T_p = the average of the inlet and the outlet water temperatures at the end of the period defined by τ_p , °F (°C).
 $v_{out,p}$ = the average flow rate during the period, gal/min (L/min).

V_{st} = the rated storage volume of the water heater, gal (L).
 τ_p = the number of minutes in the duration of the period, determined by the length of time taken for the outlet water temperature to be within 2 °F of the inlet water temperature for 15 consecutive

seconds and including the 15-second stabilization period.

$\bar{T}_{in,p}$ = the average of the inlet water temperatures during the period, °F (°C).
 $\bar{T}_{out,p}$ = the average of the outlet water temperatures during the period, °F (°C).

6.3.8 Uniform Energy Factor. The uniform energy factor, UEF, is computed as:

$$UEF = \sum_{i=1}^N \frac{M_{del,i} C_{pi} (125^{\circ}F - 58^{\circ}F)}{Q_{dm}}$$

or,

$$UEF = \sum_{i=1}^N \frac{M_{del,i} C_{pi} (51.7^{\circ}C - 14.4^{\circ}C)}{Q_{dm}}$$

Where:

N = total number of draws in the 24-hour simulated-use test.

Q_{dm} = the modified daily water heating energy consumption as computed in accordance with section 6.3.6 of this appendix, Btu (kJ).

M_{del,i} = the mass of water removed during the ith draw (i = 1 to N) as calculated in section 6.3.2 of this appendix, lb (kg).

C_{pi} = the specific heat of the water withdrawn during the ith draw of the 24-hour simulated-use test, evaluated at (125 °F +

58 °F)/2 = 91.5 °F ((51.7 °C + 14.4 °C)/2 = 33 °C), Btu/(lb·°F) (kJ/(kg·°C)).

6.3.9 *Annual Energy Consumption.* The annual energy consumption for water heaters with rated storage volumes greater than or equal to 2 gallons is computed as:

$$E_{annual} = 365 * \frac{(V)(\rho)(C_p)(67)}{UEF}$$

Where:

UEF = the uniform energy factor as computed in accordance with section 6.3.88 of this appendix.

365 = the number of days in a year.

V = the volume of hot water drawn during the applicable draw pattern, gallons.

= 10 for the very-small-usage draw pattern.

= 38 for the low-usage draw pattern.

= 55 for the medium-usage draw pattern.

= 84 for high-usage draw pattern.

ρ = 8.24 lb/gallon, the density of water at 125 °F.

C_p = 1.00 Btu/(lb °F), the specific heat of water at 91.5 °F.

67 = the nominal temperature difference between inlet and outlet water

6.3.10 *Annual Electrical Energy Consumption.* The annual electrical energy consumption in kilowatt-hours for water heaters with rated storage volumes greater than or equal to 2 gallons, E_{annual,e}, is computed as:

$$E_{annual,e} = \frac{E_{annual}}{3412} * \left(\frac{Q_e}{Q}\right)$$

Where:

E_{annual} = the annual energy consumption as determined in accordance with section 6.3.99 of this appendix, Btu (kJ).

Q_e = the daily electrical energy consumption as defined in section 6.3.5 of this appendix, Btu (kJ).

Q = total energy used by the water heater during the 24-hour simulated-use test in accordance with section 6.3.5 of this appendix, Btu (kJ).

3412 = conversion factor from Btu to kWh.

6.3.11 *Annual Fossil Fuel Energy Consumption.* The annual fossil fuel energy consumption for water heaters with rated storage volumes greater than or equal to 2 gallons, E_{annual,f}, is computed as:

$$E_{annual,f} = E_{annual} - (E_{annual,e} * 3412)$$

Where:

E_{annual} = the annual energy consumption as determined in accordance with section 6.3.9 of this appendix, Btu (kJ).

E_{annual,e} = the annual electrical energy consumption as determined in

accordance with section 6.3.10 of this appendix, kWh.

3412 = conversion factor from kWh to Btu.

6.4 *Computations for Water Heaters with a Rated Storage Volume Less Than 2 Gallons.*

6.4.1 *Mass of Water Removed*

Calculate the mass of water removed using the calculations in section 6.3.2 of this appendix.

6.4.2 *Recovery Efficiency.* The recovery efficiency, η_r, is computed as:

$$\eta_r = \frac{M_1 C_{p1} (\bar{T}_{del,1} - \bar{T}_{in,1})}{Q_r}$$

Where:

M₁ = mass of water removed during the first draw of the 24-hour simulated-use test, lb (kg).

C_{p1} = specific heat of the withdrawn water during the first draw of the 24-hour simulated-use test, evaluated at (($\bar{T}_{del,1}$ + $\bar{T}_{in,1}$)/2, Btu/(lb·°F) (kJ/(kg·°C))).

$\bar{T}_{del,1}$ = average water outlet temperature measured during the first draw of the 24-hour simulated-use test, °F (°C).

$\bar{T}_{in,1}$ = average water inlet temperature measured during the first draw of the 24-hour simulated-use test, °F (°C).

Q_r = the total energy used by the water heater during the first recovery period as defined in section 5.4.3 of this appendix, including auxiliary energy such as pilot lights, pumps, fans, etc., Btu (kJ). (Electrical auxiliary energy shall be converted to thermal energy using the following conversion: 1 kWh = 3412 Btu.)

6.4.3 *Daily Water Heating Energy Consumption.* The daily water heating energy consumption, Q_d, is computed as:

$$Q_d = Q$$

Where:

Q = Q_f + Q_e = the energy used by the water heater during the 24-hour simulated-use test.

Q_f = total fossil fuel energy used by the water heater during the 24-hour simulated-use test, Btu (kJ).

Q_e = total electrical energy used during the 24-hour simulated-use test, Btu (kJ).

(Electrical auxiliary energy shall be converted to thermal energy using the following conversion: 1 kWh = 3412 Btu.)

A modification is needed to take into account that the temperature difference between the outlet water temperature and supply water temperature may not be equivalent to the nominal value of 67 °F (125 °F – 58 °F) or 37.3 °C (51.7 °C – 14.4 °C).

The following equations adjust the experimental data to a nominal 67 °F (37.3 °C) temperature rise.

The energy used to heat water may be computed as:

$$Q_{HW} = \sum_{i=1}^N \frac{M_{del,i} C_{pi} (\bar{T}_{del,i} - \bar{T}_{in,i})}{\eta_r}$$

Where:

N = total number of draws in the 24-hour simulated-use test.

$M_{del,i}$ = the mass of water removed during the i th draw ($i = 1$ to N) as calculated in section 6.4.1 of this appendix, lb (kg).

C_{pi} = the specific heat of the water withdrawn during the i th draw of the 24-hour

simulated-use test, evaluated at $(\bar{T}_{del,i} + \bar{T}_{in,i})/2$, Btu/(lb·°F) (kJ/(kg·°C)).

$\bar{T}_{del,i}$ = the average water outlet temperature measured during the i th draw ($i = 1$ to N), °F (°C).

$\bar{T}_{in,i}$ = the average water inlet temperature measured during the i th draw ($i = 1$ to N), °F (°C).

η_r = as defined in section 6.4.2 of this appendix.

The energy required to heat the same quantity of water over a 67 °F (37.3 °C) temperature rise is:

$$Q_{HW,67°F} = \sum_{i=1}^N \frac{M_{del,i} C_{pi} (125°F - 58°F)}{\eta_r}$$

or,

$$Q_{HW,37.3°C} = \sum_{i=1}^N \frac{M_{del,i} C_{pi} (51.7°C - 14.4°C)}{\eta_r}$$

Where:

N = total number of draws in the 24-hour simulated-use test.

$M_{del,i}$ = the mass of water removed during the i th draw ($i = 1$ to N) as calculated in section 6.4.1 of this appendix, lb (kg).

C_{pi} = the specific heat of the water withdrawn during the i th draw of the 24-hour

simulated-use test, evaluated at $(\bar{T}_{del,i} + \bar{T}_{in,i})/2$, Btu/(lb·°F) (kJ/(kg·°C)).

η_r = as defined in section 6.4.2 of this appendix.

The difference between these two values is:

$$Q_{HWD} = Q_{HW,67°F} - Q_{HW}$$

or,

$$Q_{HWD} = Q_{HW,37.3°C} - Q_{HW}$$

This difference (Q_{HWD}) must be added to the daily water heating energy consumption value. Thus, the daily energy consumption value, which takes into account that the temperature rise across the water heater may not be 67 °F (37.3 °C), is:

$$Q_{dm} = Q_{da} + Q_{HWD}$$

6.4.4 *Uniform Energy Factor*. The uniform energy factor, UEF, is computed as:

$$UEF = \sum_{i=1}^N \frac{M_{del,i} C_{pi} (125°F - 58°F)}{Q_{dm}}$$

or,

$$UEF = \sum_{i=1}^N \frac{M_{del,i} C_{pi} (51.7°C - 14.4°C)}{Q_{dm}}$$

Where:

N = total number of draws in the 24-hour simulated-use test.

Q_{dm} = the modified daily water heating energy consumption as computed in accordance with section 6.4.3 of this appendix, Btu (kJ).

$M_{del,i}$ = the mass of water removed during the i th draw ($i = 1$ to N) as calculated in section 6.4.1 of this appendix, lb (kg).

C_{pi} = the specific heat of the water withdrawn during the i th draw of the 24-hour simulated-use test, evaluated at (125 °F +

58 °F)/2 = 91.5 °F ((51.7 °C + 14.4 °C)/2 = 33.1 °C), Btu/(lb·°F) (kJ/(kg·°C)).

6.4.5 *Annual Energy Consumption*. The annual energy consumption for water heaters with rated storage volumes less than 2 gallons, E_{annual} , is computed as:

$$E_{annual} = 365 * \frac{(V)(\rho)(C_p)(67)}{UEF}$$

Where:

UEF = the uniform energy factor as computed in accordance with section 6.4.4 of this appendix.

365 = the number of days in a year.

V = the volume of hot water drawn during the applicable draw pattern, gallons.

= 10 for the very-small-usage draw pattern.

= 38 for the low-usage draw pattern.

= 55 for the medium-usage draw pattern.

= 84 for high-usage draw pattern.

$\rho = 8.24$ lb/gallon, the density of water at 125 °F.

$C_p = 1.00$ Btu/(lb °F), the specific heat of water at 91.5 °F.

67 = the nominal temperature difference between inlet and outlet water.

6.4.6 Annual Electrical Energy Consumption. The annual electrical energy consumption in kilowatt-hours for water heaters with rated storage volumes less than 2 gallons, $E_{\text{annual},e}$, is computed as:

$$E_{\text{annual},e} = \frac{E_{\text{annual}}}{3412} * \left(\frac{Q_e}{Q} \right)$$

Where:

Q_c = the daily electrical energy consumption as defined in section 6.4.3 of this appendix, Btu (kJ).

E_{annual} = the annual energy consumption as determined in accordance with section 6.4.5 of this appendix, Btu (kJ).

Q = total energy used by the water heater during the 24-hour simulated-use test in accordance with section 6.4.3 of this appendix, Btu (kJ).

Q_{dm} = the modified daily water heating energy consumption as computed in accordance with section 6.4.3 of this appendix, Btu (kJ).

3412 = conversion factor from Btu to kWh.

6.4.7 Annual Fossil Fuel Energy

Consumption. The annual fossil fuel energy consumption for water heaters with rated storage volumes less than 2 gallons, $E_{\text{annual},f}$, is computed as:

Where:

E_{annual} = the annual energy consumption as defined in section 6.4.5 of this appendix, Btu (kJ).

$E_{\text{annual},e}$ = the annual electrical energy consumption as defined in section 6.4.6 of this appendix, kWh.

3412 = conversion factor from kWh to Btu.

6.5 Energy Efficiency at Optional Test Conditions. If testing is conducted at optional

test conditions in accordance with section 5.6 of this appendix, calculate the energy efficiency at the test condition, E_x , using the formulas in sections 6.3 or 6.4 of this appendix (as applicable), except substituting the applicable ambient temperature and supply water temperature used for testing (as specified in section 2.8 of this appendix) for the nominal ambient temperature and supply water temperature conditions used in the equations for determining UEF (*i.e.*, 67.5 °F and 58 °F).

7. Test Set-Up Diagrams

BILLING CODE 6450-01-P

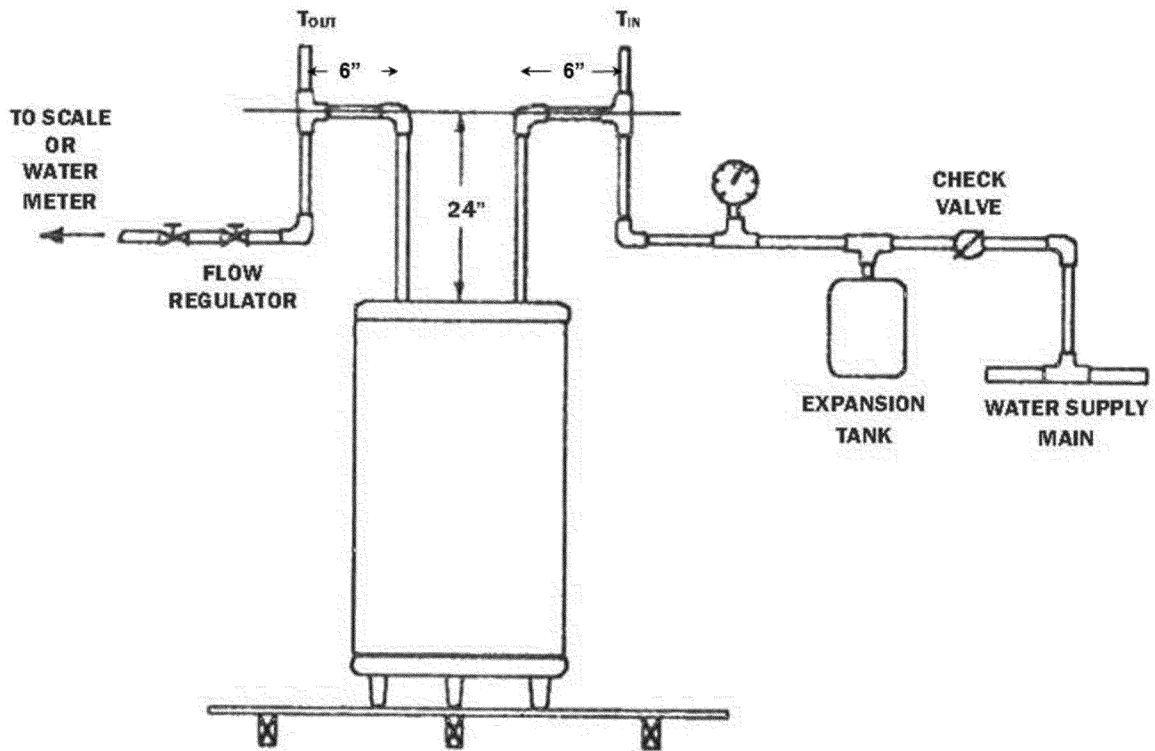

Figure 1.

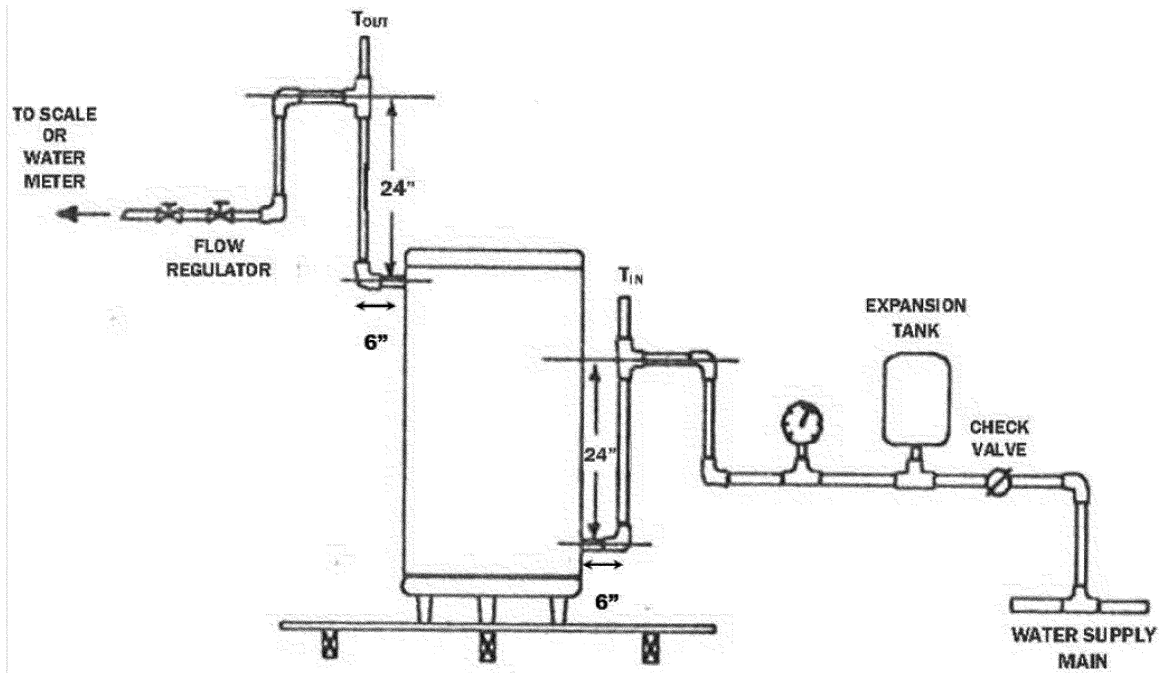

Figure 2.

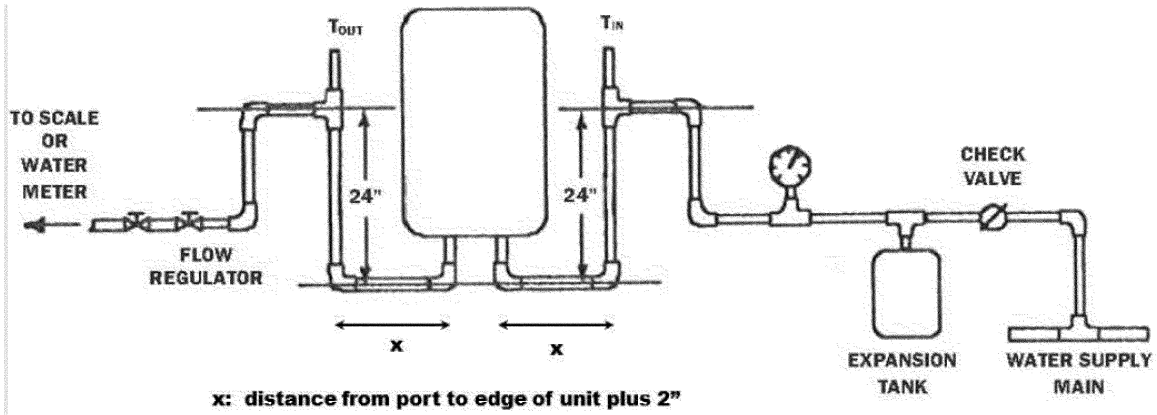

Figure 3.

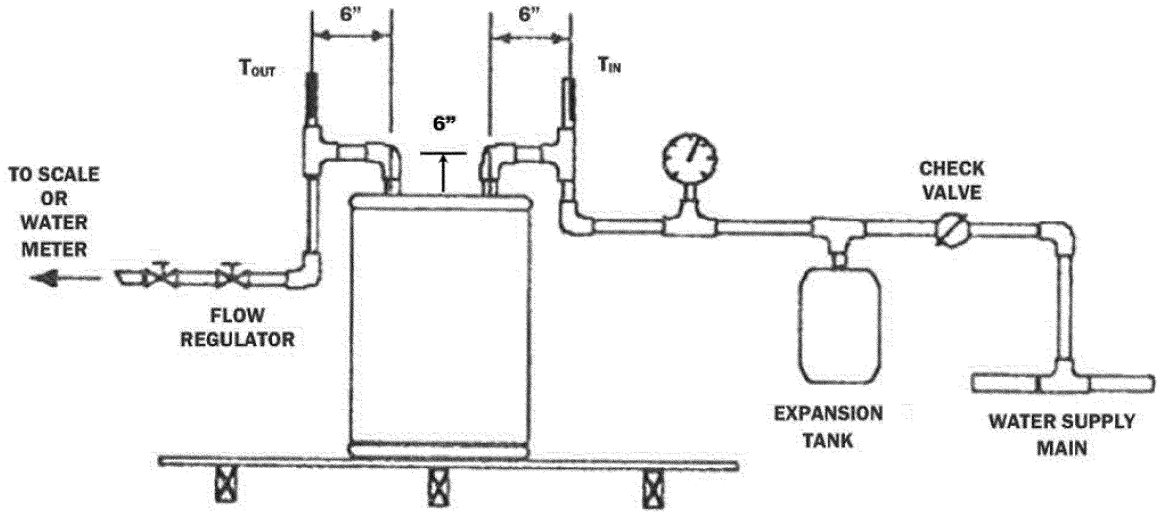

Figure 4.

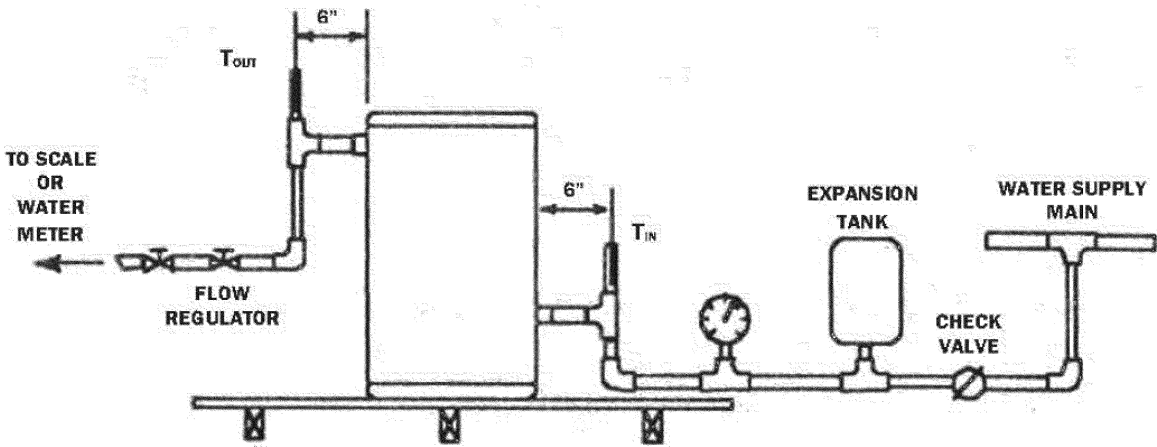

Figure 5.

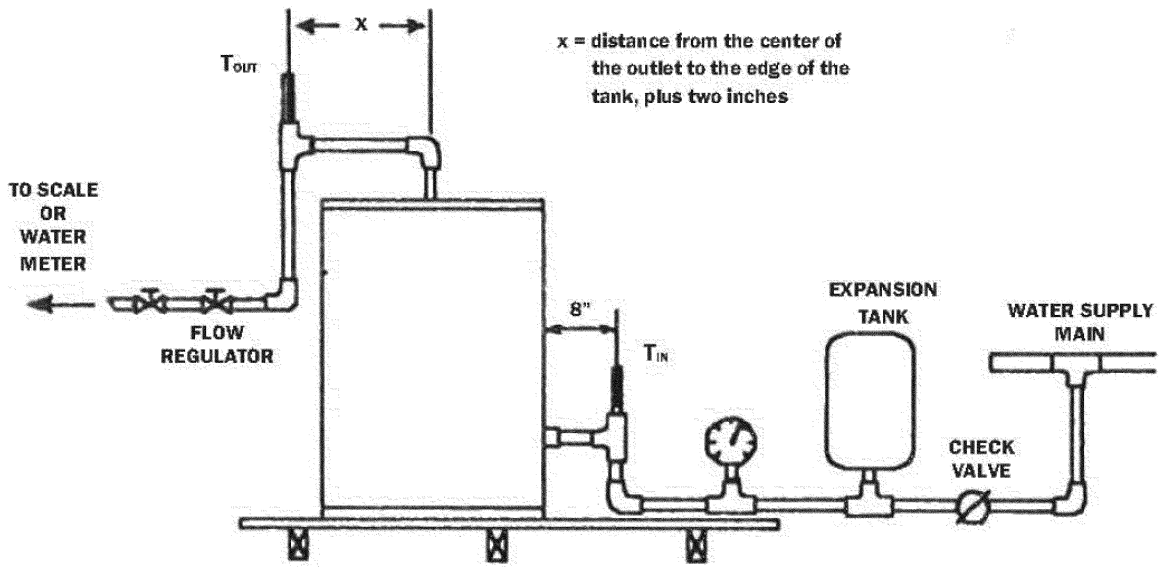

Figure 6.

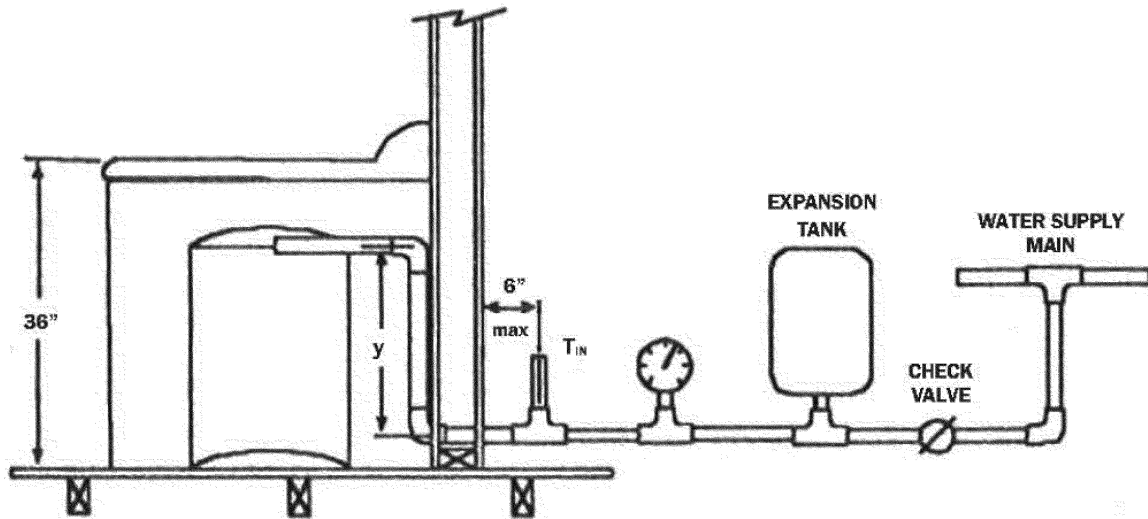
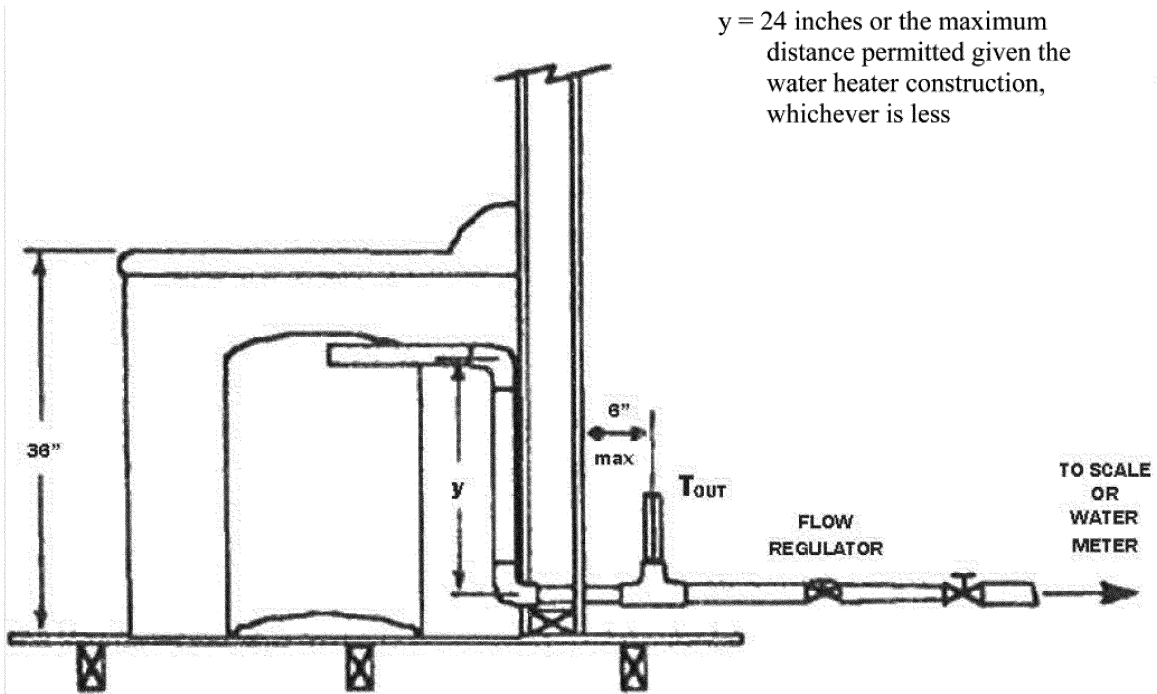

Figure 7a.



$y = 24$ inches or the maximum distance permitted given the water heater construction, whichever is less

Figure 7b.

PART 431—ENERGY EFFICIENCY PROGRAM FOR CERTAIN COMMERCIAL AND INDUSTRIAL EQUIPMENT

■ 8. The authority citation for part 431 continues to read as follows:

Authority: 42 U.S.C. 6291–6317; 28 U.S.C. 2461 note.

■ 9. Amend § 431.102 by revising the definition for “Commercial heat pump water heater (CHPWH)” to read as follows:

§ 431.102 Definitions concerning commercial water heaters, hot water supply boilers, unfired hot water storage tanks, and commercial heat pump water heaters.

* * * * *

Commercial heat pump water heater (CHPWH) means a water heater (including all ancillary equipment such as fans, blowers, pumps, storage tanks, piping, and controls, as applicable) that uses a refrigeration cycle, such as vapor compression, to transfer heat from a low-temperature source to a higher-

temperature sink for the purpose of heating potable water, and operates with a current rating greater than 24 amperes or a voltage greater than 250 volts. Such equipment includes, but is not limited to, air-source heat pump water heaters, water-source heat pump water heaters, and direct geo-exchange heat pump water heaters.

* * * * *

[FR Doc. 2023–11429 Filed 6–20–23; 8:45 am]

BILLING CODE 6450–01–C