

## CONSUMER PRODUCT SAFETY COMMISSION

### 16 CFR Parts 1112, 1130 and 1241

[CPSC Docket No. 2020–0023]

#### Safety Standard for Crib Mattresses

**AGENCY:** Consumer Product Safety Commission.

**ACTION:** Notice of proposed rulemaking.

**SUMMARY:** The Danny Keysar Child Product Safety Notification Act, section 104 of the Consumer Product Safety Improvement Act of 2008 (CPSIA), requires the United States Consumer Product Safety Commission (CPSC) to promulgate consumer product safety standards for durable infant or toddler products. These standards are to be “substantially the same as” the applicable voluntary standard, or more stringent than the voluntary standard, if the Commission determines that more stringent requirements would further reduce the risk of injury associated with the product. The Commission is proposing a safety standard for crib mattresses. The scope of the proposed rule includes full-size and non-full-size crib mattresses, as well as after-market mattresses for play yards and non-full-size cribs. The Commission is also proposing to amend CPSC’s consumer registration requirements to identify crib mattresses within the scope of the proposed rule as durable infant or toddler products, and proposing to amend CPSC’s list of notice of requirements (NORs) to include such crib mattresses.

**DATES:** Submit comments by January 11, 2021.

**ADDRESSES:** Comments related to the Paperwork Reduction Act aspects of the marking, labeling, and instructional literature requirements of the proposed mandatory standard for crib mattresses should be directed to the Office of Information and Regulatory Affairs, the Office of Management and Budget, Attn: CPSC Desk Officer, Fax: 202–395–6974, or emailed to [oir\\_submission@omb.eop.gov](mailto:oir_submission@omb.eop.gov).

Other comments, identified by Docket No. CPSC–2020–0023, may be submitted electronically or in writing:

**Electronic Submissions:** Submit electronic comments to the Federal eRulemaking Portal at: <http://www.regulations.gov>. Follow the instructions for submitting comments. CPSC does not accept comments

submitted by electronic mail (email), except through [www.regulations.gov](http://www.regulations.gov). CPSC encourages you to submit electronic comments by using the Federal eRulemaking Portal, as described above.

**Mail/Hand Delivery/Courier Written Submissions:** Submit comments by mail/hand delivery/courier to: Division of the Secretariat, Consumer Product Safety Commission, Room 820, 4330 East-West Highway, Bethesda, MD 20814; telephone: (301) 504–7479; email: [cpsc-os@cpsc.gov](mailto:cpsc-os@cpsc.gov).

**Instructions:** All submissions must include the agency name and docket number for this notification. CPSC may post all comments received without change, including any personal identifiers, contact information, or other personal information provided, to: <https://www.regulations.gov>. Do not submit electronically: Confidential business information, trade secret information, or other sensitive or protected information that you do not want to be available to the public. If you wish to submit such information, please submit it according to the instructions for mail/hand delivery/courier submissions.

**Docket:** For access to the docket to read background documents or comments received, go to: <http://www.regulations.gov>, and insert the docket number, CPSC–2020–0023, into the “Search” box, and follow the prompts.

**FOR FURTHER INFORMATION CONTACT:** Hope E J. Nesteruk, Project Manager, Directorate for Engineering, U.S. Consumer Product Safety Commission, 5 Research Place, Rockville, MD 20850; telephone: (301) 987–2547; email: [HNesteruk@cpsc.gov](mailto:HNesteruk@cpsc.gov).

#### SUPPLEMENTARY INFORMATION:

#### I. Background and Statutory Authority

##### A. Background

On June 16, 2015, the president of Keeping Babies Safe (KBS) and the mother of a child who died in an incident involving an after-market play yard mattress, petitioned the CPSC, requesting a ban on supplemental mattresses for play yards with non-rigid sides (petition CP 15–2: Petition Requesting Rulemaking on Supplemental Mattresses for Play Yards with Non-Rigid Sides). The petitioner alleged that “thicker mattresses create a suffocation hazard because they create a gap between the mattress pad sides and

the side of the portable crib where a baby can suffocate when the baby’s head falls in such gap while lying in the prone position.” Petitioner asserted that “no feasible consumer product safety standard would adequately protect babies from the unreasonable risk of injury and death associated with the product.”

CPSC staff prepared a briefing package for the petition, recommending that the Commission defer action on the petition, so that staff could work on voluntary standards for crib mattresses and play yards to address the hazards identified in the petition. Staff noted that any work on the play yard voluntary standard could become a mandatory standard through the Public Law 112–28 update process, because the Commission has an existing mandatory standard for play yards (16 CFR part 1221); however, any changes to the crib mattress voluntary standard would remain a voluntary standard, because the Commission does not have a mandatory rule for crib mattresses.

On May 25, 2017, in response to the petition request and staff’s recommendation to defer the petition, the Commission voted <sup>1</sup> (3–2) to “take other action” and granted the petition, directing staff to: (1) Initiate a rulemaking under section 104 of the CPSIA for a mandatory consumer product safety standard that will address the risk of injury associated with the use of crib mattresses, (2) include “supplemental and aftermarket mattresses used in play yards and portable cribs”<sup>2</sup> within the scope of the crib mattress rulemaking, and (3) update the product registration card rule (16 CFR part 1130) to include “crib mattresses” in the list of durable infant or toddler products subject to the rule.

<sup>1</sup> [https://www.cpsc.gov/s3fs-public/RCA-Petition\\_CP\\_15-2\\_Requesting\\_Ban\\_on\\_Supplemental\\_Mattresses\\_for\\_Play\\_Yards\\_with\\_Non-Rigid\\_Sides\\_052517.pdf](https://www.cpsc.gov/s3fs-public/RCA-Petition_CP_15-2_Requesting_Ban_on_Supplemental_Mattresses_for_Play_Yards_with_Non-Rigid_Sides_052517.pdf).

<sup>2</sup> Although the petitioner used the term “supplemental mattress,” ASTM F2933–19 uses and defines the term “after-market” mattress. Both terms refer to a mattress that is bought separately from a play yard or non-full-size crib. This NPR will use the defined term “after-market” mattress. Section 3.1.1 of ASTM F2933–19 defines an “after-market mattress for a play yard or non-full-size crib” as “a mattress sold or distributed for a play yard or non-full-sized crib.” Section 3.1.1.1 of ASTM F2933–19 states that it does not include a replacement mattress sold by an original equipment manufacturer as a replacement, if it is equivalent to the mattress originally provided with the product.

The Commission issues this notice of proposed rulemaking (NPR) under section 104 of the CPSIA to propose a mandatory consumer product safety standard for crib mattresses.<sup>3</sup> Unless otherwise stated, the term “crib mattresses” in this NPR includes products within the scope of the voluntary standard for crib mattresses, ASTM F2933–19, *Standard Consumer Safety Specification for Crib Mattresses* (ASTM F2933–19): Full-size crib mattresses, non-full-size mattresses, and after-market mattresses for play yards and non-full-size crib mattresses.

### B. Statutory Authority

Section 104(b) of the CPSIA requires the Commission to: (1) Examine and assess the effectiveness of voluntary consumer product safety standards for durable infant or toddler products, in consultation with representatives of consumer groups, juvenile product manufacturers, and independent child product engineers and experts; and (2) promulgate consumer product safety standards for durable infant or toddler products. 15 U.S.C. 2056a(b). Standards issued under section 104 are to be “substantially the same as” the applicable voluntary standards, or more stringent than the voluntary standard, if the Commission determines that more stringent requirements would further reduce the risk of injury associated with the product. *Id.* at 2056a(b)(1)(B).

Regarding the consultation requirement in section 104(b)(1) of the CPSIA, CPSC staff regularly participates in the juvenile products subcommittee meetings of ASTM International (ASTM). ASTM subcommittees consist of members who represent producers, users, consumers, government, and academia.<sup>4</sup> The consultation process for the crib mattresses rulemaking commenced during the ASTM subcommittee meeting in May 2018, when CPSC staff presented initial recommendations for updating the crib mattress voluntary standard to address the incident data. Since then, staff has actively participated with the ASTM F15.66 subcommittee for Crib Mattresses in revising ASTM F2933,

*Standard Consumer Safety Specification for Crib Mattresses*, to address the associated hazards.

Section 104(d) of the CPSIA requires manufacturers of durable infant or toddler products to establish a product registration program and comply with CPSC’s implementing rule, 16 CFR part 1130. Any product defined as a “durable infant or toddler product” in part 1130 must comply with the product registration requirements, as well as testing and certification requirements for children’s products, as codified in 16 CFR parts 1107 and 1109. Section 104(f)(1) of the CPSIA defines a “durable infant or toddler product” as a “durable product intended for use, or that may be reasonably expected to be used, by children under the age of 5 years.” 15 U.S.C. 2056a(f)(1). Section 104(f)(2) of the CPSIA includes a list of categories of products that are durable infant or toddler products, including infant sleep products, such as cribs (full-size and non-full-size), toddler beds, bassinets and cradles, and play yards. *Id.* 2056a(f)(2).

Although crib mattresses are used with infant sleep products, crib mattresses are not included in the statutory list of durable infant or toddler products. The Commission proposes to amend part 1130 to include “crib mattresses” within the scope of ASTM F2933, as durable infant or toddler products. As set forth in section IX of this preamble, the Commission previously explained that the statutory product list is not exhaustive, and the Commission has added products to the list of durable infant or toddler products. The Commission proposes to include “crib mattresses” as a “durable infant or toddler product” because: (1) They are intended for use, and may be reasonably expected to be used, by children under the age of 5 years; (2) they are products similar to the products listed in section 104(f)(2) of the CPSIA; (3) they are used in conjunction with other durable infant or toddler products used for unattended infant sleep, such as cribs, bassinets, and play yards; and (4) CPSC cannot fully address the risk of injury associated with such infant sleep products without addressing the hazards associated with the use of crib mattresses in these infant sleep products.

### C. NPR Overview

Pursuant to section 104 of the CPSIA, the Commission proposes to issue a mandatory standard for crib mattresses, incorporating by reference ASTM F2933–19, with modifications to make the standard more stringent, to further

reduce the risk of injury associated with the use of crib mattresses. Proposed modifications in this NPR address: (1) Suffocation hazards associated with crib mattresses, due to overly soft mattresses, by adding a test for mattress firmness based on sections 6 and 8 of *AS/NZS 8811.1:2013—Methods of testing infant products—Method 1: Sleep Surfaces—Test* (AS/NZS 8811.1); (2) entrapment hazards associated with full-size crib mattresses, due to poor mattress fit from compression by sheets, by repeating the dimensional conformity test and measuring for corner gaps, after installing a shrunken (by washing twice) cotton sheet; (3) entrapment hazards associated with after-market, non-full-size crib mattresses, due to lack of dimensional requirements for rectangular-shaped products, by extending the dimensional requirements in ASTM F2933–19 section 5.7.2 to all non-full-size crib mattresses, regardless of mattress shape, and regardless of whether the mattress is sold with a non-full-size crib or as an after-market mattress; (4) laceration hazards associated with coils and springs breaking and poking through mattresses, by adding a cyclic impact test for mattresses that use coils and springs; and (5) the risks of SIDS and suffocation related to infant positioning, soft bedding, and gap entrapment, by improving the labeling and instructional literature requirements to communicate risks better to consumers, and to clarify requirements for manufacturers and test labs.

The Commission also proposes to amend the consumer registration rule, part 1130, to identify “crib mattresses” as a category of “durable infant or toddler products” subject to the rule. Finally, the Commission proposes to amend its regulation at 16 CFR part 1112 to add “crib mattresses” to the list of products that require third-party testing as a basis for certification.

This NPR is based on information provided in the September 30, 2020, Staff Briefing Package: Draft Notice of Proposed Rulemaking for Crib Mattresses<sup>5</sup> Under the Danny Keysar Child Product Safety Notification Act (Staff’s NPR Briefing Package), available at: <https://www.cpsc.gov/s3fs-public/Notice-of-Proposed-Rulemaking-Safety-Standard-for-Crib-Mattresses.pdf?mDLf.MBLutFluwt6QFjeZRhYdNLFRRJ>.

<sup>3</sup> Previously, on November 21, 2016, the Commission issued a notice of proposed rulemaking for a Safety Standard for Portable Generators, proposing to codify the standard at 16 CFR part 1241. 81 FR 83556. The Commission is reusing part 1241 for this proposed rule for a Safety Standard for Crib Mattresses, to keep all regulations for durable infant or toddler products in one section of the Code of Federal Regulations (CFR). The Commission intends to renumber the CFR citation for portable generators when that rulemaking is finalized.

<sup>4</sup> ASTM International website: [www.astm.org](http://www.astm.org). About ASTM International.

<sup>5</sup> As well as supplemental and after-market mattresses used in play yards and portable cribs.

## II. Product Description

### A. Scope of Products Within the NPR<sup>6</sup>

The scope of the NPR includes all crib mattresses<sup>7</sup> within the scope of ASTM F2933–19, which addresses three types of crib mattresses:

1. *Full-size crib mattresses*—Full-size crib mattresses within the scope the proposed rule are typically sold separately from the crib in which they are intended to be used. Industry refers to full-size crib mattresses as a “standard” crib mattress. Full-size crib mattresses are also used for toddler beds, meaning that one full-size crib mattress may be used from birth through the toddler years. The fit of a crib mattress inside of a crib is key to preventing infants from becoming trapped between the side of the crib and the mattress, and suffocating.

Accordingly, section 5.7 of ASTM F2933–19 requires that the dimensions of a full-size crib mattress shall measure at least 27¼ in. wide and 51⅝ in. long. The interior dimensions of full-size cribs are 28 ± ⅝ in. (710 ± 16 mm) wide and 52⅜ ± ⅝ in. (1330 ± 16 mm) long. Full-size crib mattresses come in a variety of designs and are made of a broad array of materials. Full-size crib mattresses typically have a fabric or vinyl ticking, which covers inner-spring coils or foam. Inner-spring mattresses often have a layer of foam or batting between the springs and the ticking.

2. *Non-full-size crib mattresses*—Non-full-size cribs are cribs that differ in dimension or shape from “standard” full-size cribs. The NPR addresses all non-full-size crib mattresses, regardless of whether they are sold separately (after-market), or are sold with a non-full-size crib (referred to as original equipment manufactured mattresses or OEM mattresses), and regardless of whether they are rectangular or non-rectangular in shape.<sup>8</sup> Because non-full-size cribs do not come in a standard size, non-full-size crib mattresses do not have defined dimensions. Rather, ASTM

F2933–19 sets a minimum effective crib-side height for non-full-size cribs and a maximum gap between the mattress edge and the crib side.<sup>9</sup> Section 5.7.2.1 of ASTM F2933–19 requires that the dimensions of a mattress supplied with a non-full-size baby crib shall be such that the mattress, when inserted in the center of the crib, in a non-compressed state, shall not leave a gap of more than ½ in. at any point between the perimeter of the mattress and the perimeter of the crib. Currently, section 5.9 of ASTM F2933–19 requires that after-market, non-rectangular, non-full-size crib mattresses be identical to the OEM non-full-size crib mattresses they are intended to replace, but only requires warning labels regarding dimensions on after-market, rectangular-shaped, non-full-size crib mattresses. The Commission proposes in the NPR to extend this dimensional requirement to all after-market, non-full-size cribs, including non-rectangular and rectangular, non-full-size mattresses.

3. *After-market mattresses for play yards*—After-market mattresses are products sold separately from a play yard,<sup>3</sup> and that are not sold by the OEM as a replacement mattress for their product. Pursuant to CPSC’s mandatory rule for play yards, part 1221, which incorporates by reference ASTM F406–19, *Standard Consumer Safety Specification for Non-Full-Size Baby Cribs/Play Yards* (ASTM F406), all play yards must be sold with a mattress that is specifically designed to fit that product. Part 1221 regulates OEM play yard mattresses, but does not address after-market play yard mattresses. This Commission proposes in the NPR to address after-market mattresses for play yards, as set forth in ASTM F2933–19 section 5.9, by requiring that they meet the same specifications and performance requirements for OEM play yard mattresses. Additionally, the NPR would require that after-market mattresses intended for use in the bassinet of a play yard with a bassinet attachment must also meet the specifications in ASTM F2194, *Consumer Safety Specifications for Bassinets and Cradles*.

### B. Market Description<sup>10</sup>

Crib mattresses are designed to be used with infant sleep products, such as full-size cribs, non-full-size cribs, bassinets and cradles, and play yards, to provide sleeping accommodations for an infant. According to estimates published by Statista-Grand View Research, the size of the U.S. market for standard and portable cribs was \$86.8 million in 2018.<sup>11</sup> According to data collected by staff, approximately 75 percent of crib mattresses available for sale in the United States are standard (full-size) crib mattresses, and 7 percent are mini crib mattresses.

Crib mattresses range in price from \$20 to \$500, with the more expensive crib mattresses typically being full-size crib mattresses with a firm coil or high-end foam core. Crib mattresses are sometimes also sold with waterproof covers and fitted sheets, specifically designed to be used with the mattress. While some manufacturers produce a large variety of crib mattress models, others produce only a small selection. Many crib mattresses are GreenGuard Certified, which is a UL-sponsored standard intended to reduce the emissions of volatile organic compounds from products.<sup>12</sup> Additionally, many full-size crib mattresses are advertised online as meeting the CPSC mattress and mattress pad flammability requirements.<sup>13</sup>

If finalized, a mandatory rule for crib mattresses will require third party testing for conformance to the new crib mattress rule, 16 CFR part 1241, and a certificate of compliance. Crib mattresses already require third party testing and certification, because crib mattresses are already defined as “children’s products,” and are currently subject to various other federal safety rules, such as mattress flammability, lead, and phthalate testing. Accordingly, a final rule for crib mattresses will incrementally increase the amount of crib mattress testing and certification requirements already in place.

### C. Crib Mattress Use<sup>11</sup>

Based on information from the 2013 CPSC Durable Nursery Products Exposure Survey (DNPES) of U.S. households with children under 6 years old, an estimated 9.2 million cribs were in use in households with young

<sup>6</sup> See Staff’s NPR Briefing Package at Tab B for additional information on the scope of ASTM F2933–19.

<sup>7</sup> Section 3.1.4 of ASTM F2933–19 defines a “crib” as a “bed that is designed to provide sleeping accommodations for an infant which have specific interior dimensions as determined by it being either a full size or non-full size crib.” Section 3.1.5 of ASTM F2933–19 defines a “mattress” as “ticking filled with a resilient material used alone or in combination with other products intended or promoted for sleeping on it.”

<sup>8</sup> We note that OEM non-full-size crib mattresses are also addressed in the Commission’s mandatory rule for non-full-size cribs, 16 CFR part 1220, which incorporates by reference ASTM F406. The requirements in F406 for OEM non-full-size crib mattresses are the same requirements that appear in ASTM F2933 section 5.7.

<sup>9</sup> The most common rectangular, non-full-size crib mattress available for sale in the U.S. crib mattress market is the “mini” crib mattress. The mini crib mattress is smaller than the so-called “standard” or full-size crib mattress. The typical size of a “mini” crib mattress is 24” wide and 38” long. The depth of a “mini” crib mattress varies, but typically ranges from 1” to 6”.

<sup>10</sup> See Staff’s NPR Briefing Package at Tab F for additional information on the marketing and use of crib mattresses.

<sup>11</sup> November 2019 Statista estimates, Grand View Research.

<sup>12</sup> <https://www.ul.com/resources/ul-greenguard-certification-program>.

<sup>13</sup> Review of manufacturers’ websites, product labels, and materials.

children in 2013.<sup>14</sup> This represented about 73 percent of the estimated 12.6 million total cribs owned by households (*i.e.*, about 3.4 million cribs were owned, but not in use). Cribs, for the purposes of the DNPES, included both full-size and non-full-size cribs, which are designed to be used with a crib mattress; therefore, staff estimates at least 9.2 million (full-size and non-full-size) crib mattresses were in use in 2013.<sup>15</sup> According to DNPES results, 84 percent of respondents indicated they used a fitted sheet on the crib mattresses, and 50 percent indicated they used a mattress pad. Six percent of respondents indicated that nothing was placed under the child in the crib, other than the intended mattress, indicating that the crib mattress was used bare.

According to the same survey, an estimated 5.8 million play yards were in use in households with young children. This represented about 54 percent of the estimated 10.9 million total play yards owned by households (*i.e.*, about 5.1 million play yards were owned, but not in use). Most play yards are designed to be used with a play yard mattress; therefore, staff estimates at least 5.8 million play yard mattresses were in use in 2013. Twenty-five percent of respondents indicated that nothing was placed under the child in the play yard,

other than the intended mattress; 12 percent indicated they used a mattress pad, but no respondents indicated that they used a fitted sheet.

The DNPES did not cover child care facilities. One childcare industry group's 2018 directory<sup>16</sup> lists more than 115,000 licensed childcare centers and more than 137,000 home daycare providers, some of which may use crib or play yard mattresses. Furthermore, the survey did not cover hotels or other commercial lodging establishments. The U.S. Bureau of Labor Statistics (BLS) reports that there are about 70,000 lodging establishments in the accommodation industry sector, North American Industry Classification System (NAICS) code 721.<sup>17</sup> Based on the Commission's contacts with childcare and lodging facilities, crib, play yard, and crib mattresses are commonly used in such establishments.<sup>18</sup>

### III. Incident Data and Hazard Patterns<sup>19</sup>

Staff of CPSC's Directorate for Epidemiology, Division of Hazard Analysis (EPA), searched the Consumer Product Safety Risk Management System<sup>20</sup> (CPSRMS) and the National Electronic Injury Surveillance System (NEISS) for

fatalities, incidents, and concerns associated with crib mattresses, reported to have occurred between January 1, 2010 and March 31, 2020.<sup>21</sup> Staff identified 21 NEISS cases associated with a crib mattress. Because the data did not meet the minimum criteria for reporting an estimate,<sup>22</sup> staff included the 19 NEISS injuries and two NEISS fatalities with the other reported incident data for crib mattresses.

#### A. Incident Severity

The Commission is aware of 439 reports associated with a crib mattress. Table 1 presents the severity of the reported cases, in order of severity. Of the 439 reports, 116 reports (26 percent) involved a fatality; 15 reports (3 percent) required an infant to receive treatment in an emergency room; and 4 reports (1 percent) required hospital admission. Reports for 199 incidents (45 percent) describe incidents that resulted in no injuries; and 16 reports (4 percent) describe no actual incidents or injuries. In the 199 incident reports with no injuries reported, staff observed that, generally, caregivers intervened once they identified a problem with the crib mattress, and the mattress was no longer used after the caregiver identified the hazard.

TABLE 1—REPORTS ASSOCIATED WITH CRIB MATTRESSES BY SEVERITY, JANUARY 1, 2010–MARCH 31, 2020

Severity	Number of reports	%
Fatalities .....	116	26
Emergency Department Treatment Received .....	15	3
Hospital Admission .....	4	1
Seen by Medical Professional .....	1	<1
First Aid Received by Non-Medical Professional .....	1	<1
Level of care not known .....	66	15
Incident, No Injury .....	199	45
No First Aid or Medical Attention Received .....	8	2
No Incident, No Injury .....	16	4
Unspecified .....	13	3
<b>Total .....</b>	<b>439</b>	<b>100</b>

Source: CPSRMS and NEISS databases—Reporting is ongoing; 2018–2020 are considered incomplete.

<sup>14</sup> Respondents were asked to include in their count of cribs owned, cribs that had been converted into toddler beds; but they were instructed to include only the time used in the product as a crib, in response to use questions.

<sup>15</sup> In addition to the products in use in households with young children, as estimated from the survey, cribs and crib mattresses are probably in use in some households without young children (*e.g.*, unsurveyed homes of older adults providing care for grandchildren).

<sup>16</sup> Child Care Centers estimate entire U.S. (2018, April 27). <http://childcarecener.us/>.

<sup>17</sup> U.S. Bureau of Labor Statistics, "Quarterly Census of Employment and Wages," April 2018. <http://www.bls.gov/iag/tgs/iag721.htm>.

<sup>18</sup> Staff contacts included phone inquiries with daycare and hotel establishments.

<sup>19</sup> See Staff's NPR Briefing Package at Tab A, for additional information on staff's review of crib mattress incidents.

<sup>20</sup> CPSRMS is the epidemiological database that houses all anecdotal reports of incidents received by CPSC, "external cause"-based death certificates purchased by CPSC, all in-depth investigations of these anecdotal reports, as well as investigations of select NEISS injuries. Examples of documents in CPSRMS are: Hotline reports, internet reports, news reports, medical examiner's reports, death certificates, retailer/manufacturer reports, and documents sent by state/local authorities, among others.

<sup>21</sup> Some of the nonfatal reports described concerns about potential hazards associated with a

crib mattress, without an actual incident occurring. Staff initially extracted incident reports and NEISS injury cases using nine product codes, with no other restrictions on the extraction criteria. Staff then reviewed each record to determine whether a report was associated with a crib mattress. Staff searched the following product codes: *Playpens and play yards* (1513), *portable cribs* (1529), *bassinets or cradles* (1537), *baby mattresses or pads* (1542), *cribs, nonportable* (1543), *cribs, not specified* (1545), *mattresses, not specified* (4010), *toddler beds* (4082), and a catch-all product code 9101.

<sup>22</sup> NEISS estimates are reportable, provided the sample count is greater than 20, the national estimate is 1,200 or greater, and the coefficient of variation (CV) is less than 0.33.

**B. Hazard Categories for Fatal and Nonfatal Reports**

The Commission is aware of 116 reported deaths and 323 nonfatal

incidents and concerns associated with crib mattresses that were reported to have occurred between January 1, 2010 and March 31, 2020. Table 2 presents

hazard categories, which are further defined in the *Fatal Reports* and *Reported Nonfatal Incidents and Concerns* sections below.

**TABLE 2—FATAL AND NONFATAL REPORTS ASSOCIATED WITH CRIB MATTRESSES BY HAZARD CATEGORY, JANUARY 1, 2010–MARCH 31, 2020**

Hazard category	Fatal reports	Nonfatal reports	Total reports
Chemical/Flammability .....	0	23	23
Coil or Spring .....	0	124	124
Crib Mattress Used in a Play Yard .....	2	1	3
Expand or Inflate .....	0	6	6
Face in Mattress .....	13	1	14
Fit Issues .....	20	88	108
Found Prone .....	66	3	69
Mattress Falls Apart .....	0	18	18
Softness .....	0	36	36
Multiple Contributing Factors (MCF) .....	15	17	32
Other .....	0	6	6
<b>Total .....</b>	<b>116</b>	<b>323</b>	<b>439</b>

Source: CPSRMS and NEISS databases—Reporting is ongoing; 2018–2020 are considered incomplete.

**C. Fatal Reports**

The Commission is aware of 116 reported deaths associated with crib

mattresses that were reported to have occurred between January 1, 2010 and

March 31, 2020. Table 3 presents hazard categories associated with fatalities.

**TABLE 3—REPORTED FATALITIES ASSOCIATED WITH CRIB MATTRESSES BY HAZARD CATEGORY, JANUARY 1, 2010–MARCH 31, 2020**

Hazard category	Reported deaths	%
Crib Mattress Used in a Play Yard .....	2	2
Face in Mattress .....	13	11
Fit Issues .....	20	17
Found Prone .....	66	57
Multiple Contributing Factors (MCF) .....	15	13
<b>Total .....</b>	<b>116</b>	<b>100</b>

Source: CPSRMS and NEISS databases—Reporting is ongoing; 2018–2020 are considered incomplete.

**1. Crib Mattress Used in a Play Yard:**

Two percent of the fatalities involved use of a crib mattress in a play yard (2 out of 116). Reports state that infants were found wedged between the crib mattress and the mesh of the play yard, due to the crib mattress not fitting snugly in the play yard.

**2. Face in Mattress:** Eleven percent (13 out of 116) of fatalities were associated with the face of an infant, when found, reportedly in contact with a crib mattress or crib sheet covering the crib mattress. Based on the available information about each fatality, bedding, other than a sheet, was present in the sleeping environment in some of these reports, but the bedding was not touching the infant, nor did staff determine that the bedding was a contributing factor in the death.

**3. Fit Issues:** Seventeen percent (20 out of 116) of fatalities involved issues

with the fit of a crib mattress in the sleeping environment. In all of these fatalities, the infants became wedged in gaps between at least one of the sides of a crib mattress and the crib rails or play yard mesh.

**4. Found Prone:** Fifty-seven percent (66 out of 116) of fatalities involved an infant found in a prone position with no mention of whether the face of the child was in contact with the crib mattress or crib sheet, and no mention of the face being obstructed by other crib bedding, or other items in the sleep environment. Given the available information about each fatality, bedding was present in the sleeping environment in some of these reports, but staff did not determine that bedding was a contributing factor in the deaths.

**5. Multiple Contributing Factors (MCF):** Thirteen percent (15 out of 116) of fatalities involved multiple factors

that potentially played a role in the fatality, and the crib mattress was likely one of the contributing factors. Examples of other contributing factors are entrapment between the mattress and bumper pads, entrapment between the mattress and a crib rail with limb entrapment, usage of a swaddle, sharing of the sleep environment with another infant, and congenital or recent health conditions.

CPSC staff identified the age and gender of the infant in every reported fatality. The oldest-aged children associated with crib mattress fatalities were: One 3-year-old, and two 2-year-old children. Staff observed considerably more reported prone fatalities between the ages of 1 month and 5 months, and most of the deaths in the fit, face in mattress, and MCF hazard categories involved infants between the ages of 1 month and 8

months, compared to other ages. Of the 116 reported fatalities associated with crib mattresses, 74 deaths (64 percent) were male and 42 deaths (36 percent) were female.

#### D. Nonfatal Reports and Concerns

The Commission is aware of 323 reported nonfatal incidents and concerns associated with crib mattresses

that were reported to have occurred between January 1, 2010 and March 31, 2020. Table 4 presents the hazard categories associated with nonfatal crib mattress reports.

TABLE 4—NONFATAL REPORTS ASSOCIATED WITH CRIB MATTRESSES BY HAZARD CATEGORY, JANUARY 1, 2010–MARCH 31, 2020

Hazard category	Nonfatal reports	%
Chemical/Flammability .....	23	7
Coil or Spring .....	124	38
Crib Mattress Used in a Play Yard .....	1	<1
Expand or Inflate .....	6	2
Face in Mattress .....	1	<1
Fit Issues .....	88	27
Found Prone .....	3	1
Mattress Falls Apart .....	18	6
Softness .....	36	11
Multiple Contributing Factors (MCF) .....	17	5
Other .....	6	2
<b>Total .....</b>	<b>323</b>	<b>100</b>

Source: CPSRMS and NEISS databases—Reporting is ongoing; 2018–2020 are considered incomplete.

As shown in Table 4, the hazard categories with the most reported nonfatal incidents associated with crib mattresses are issues with coils or springs, and crib mattresses that do not fit properly in the sleep environment.<sup>23</sup> We describe the non-fatal incidents associated with each identified hazard category as follows:

1. *Chemical/Flammability*: Seven percent (23 out of 323) of the nonfatal incidents reported a crib mattress having a chemical odor (5), causing rashes (7), or not meeting mandatory federal flammability standards (11). Infants were reported to have suffered from rashes and upper respiratory issues.

2. *Coil or Spring*: Thirty-eight percent (124 out of 323) of nonfatal incidents involved a coil or spring found protruding through the crib mattress. A 2-year-old received two stitches in the hospital emergency department for a laceration injury. Another 2-year-old with a toe laceration was treated and released from the hospital emergency department.

3. *Crib Mattress Used in a Play Yard*: Less than 1 percent (1 out of 323) of nonfatal incidents involved an infant's back being scratched by protruding coils or springs of a crib mattress being used in a play yard.

4. *Expand or Inflate*: Two percent (6 out of 323) of nonfatal incidents

involved a crib mattress that failed to expand or inflate properly. Staff identified related hazards, including fit issues with gaps appearing around the crib mattress causing entrapment or wedging, and an uneven crib mattress that may cause an infant to roll over.

5. *Face in Mattress*: Less than 1 percent (1 out of 323) of nonfatal incidents involved an infant found limp, pale, and with blue around the lips while face down in contact with a crib mattress. Staff found no other details about the sleep environment in this incident. The 1-month-old infant was admitted to the hospital.

6. *Fit Issue*: Twenty-seven percent (88 out of 323) of nonfatal incidents involved issues with the fit of a crib mattress in the sleeping environment. In all of these reports, staff determined that gaps were present on one or more sides around the perimeter of a crib mattress, creating wedging or entrapment hazard between the crib mattress and the crib rails or play yard mesh. A 3-month-old went into cardiac arrest and was admitted to the hospital after being found between a crib mattress and a crib frame. Six children between the ages of 6 months old and 2 years old, and a 10-year-old with Rett syndrome,<sup>24</sup> were

treated and released from the hospital emergency department due to entrapment between a crib mattress and crib rails, and sustaining injuries, such as an arm or leg fracture, a mid-back injury, a foot injury, lip hematoma, and a nursemaid's elbow.

7. *Found Prone*: One percent (3 out of 323) of nonfatal incidents involved an infant found in a prone position without any mention of the face being in contact with the mattress or crib sheet, and no mention of the face being obstructed by other crib bedding or other items in the sleep environment. Staff found no other details about the sleep environment in any of these three reported incidents. Among these three infants, an 8-month-old was admitted to the hospital after being found breathing poorly; and two infants received treatment in the emergency department: A 4-month-old was found breathing poorly, and a 1-month-old was found not breathing, while vomiting and choking.

8. *Mattress Falls Apart*: Six percent (18 out of 323) of nonfatal incidents involved part of a crib mattress coming apart. In most of these reports, the seams of the mattress unraveled, creating: A strangulation hazard due to the stitching of the mattress being exposed; and a choking or ingestion hazard due to the inner filling coming out of the mattress in small pieces and into the sleep environment. Examples of reported small pieces of a crib mattress filling that came apart are fibers, string, or wool. Staff found that in six incidents, string from crib mattress seams or piping was found wrapped around the neck of the infant, which

<sup>23</sup> In the most recent 2 years, from January 2018 to March 2020, CPSC observed fewer nonfatal reports of coil or spring issues associated with crib mattresses, compared to years 2014 through 2017. Eighty-nine percent (78 out of 88 nonfatal reports) of nonfatal reports involving fit issues occurred between 2010 and 2015.

<sup>24</sup> According to <https://www.rettsyndrome.org>, "Rett syndrome is a rare genetic neurological disorder that occurs almost exclusively in girls and leads to severe impairments, affecting nearly every aspect of the child's life: Their ability to speak, walk, eat, and even breathe easily. The hallmark of Rett syndrome is near-constant repetitive hand movements. Rett syndrome is usually recognized in children between 6 to 18 months as they begin to miss developmental milestones or lose abilities they had gained."

could have led to a serious outcome if the child was not found in time. One incident involved an infant choking on a plastic piece of 'shredded' crib mattress, and 1 incident involved a 2-year-old who was treated and released from the hospital emergency department due to ingesting plastic pieces of a crib mattress.

9. *Softness*: Eleven percent (36 out of 323) of nonfatal incidents involved a crib mattress inner cushioning that was reportedly too soft. Staff found 17 reports of depressions or indentations in the crib mattress, accompanied by the following descriptions: "bunches up/squishy," "depression/dips/indentation/sinks in/sunken," and "deflates/like an air mattress not fully inflated." Twelve reports describe a crib sheet being placed on a crib mattress and causing the mattress to bend or bow, resulting in a gap or fit issue between the mattress and crib rails, creating an entrapment hazard. Four reports claim that a crib mattress is not breathable. Three reports allege that a crib mattress is too thin and that the inner cushioning is too soft.

10. *Multiple Contributing Factors (MCF)*: Five percent (17 out of 323) of nonfatal incidents involved multiple factors that played a role, of which the crib mattress was likely one factor. Staff found that in 10 reports, an infant was found wedged between a crib mattress and the crib rail, while an arm, leg, or foot was caught in between the slats of the crib. Additionally, one infant in a sleep sack was found face down while reportedly attempting to turn over, and another child was found face down in a crib while having a seizure. Among the most serious injuries reported were two children who were treated and released from the hospital emergency department: A 5-month-old received a leg fracture after becoming entrapped under a crib mattress while also having an arm caught between the slats of the crib, and an 18-month-old was found face down on a crib mattress while having a seizure.

11. *Other*: Two percent (6 out of 323) of nonfatal incidents involved miscellaneous other issues associated with a crib mattress. Reports in this category include: A blade found in a crib mattress; an infant's arm was "tangled in a crib mattress"; an infant "slipped on a crib mattress," causing a slat entrapment; an infant's arm became "stuck on a crib mattress"; a crib mattress had a loose plastic bag for a cover; and a concern about crib mattresses not having proper warning labels to direct caregivers to place infants on their backs when putting them down in a crib. The 7-month-old

infant who was "tangled in a crib mattress" was admitted to the hospital due to a leg fracture. The 9-month-old who was "stuck on a crib mattress" was treated and released from the hospital emergency department due to a nursemaid's elbow.

#### *E. Explanation of Hazards Associated With Crib Mattress Use*<sup>25</sup>

After reviewing the incident data, CPSC staff identified various mattress-use factors associated with deaths and serious injuries related to sudden and unexpected infant death (SUID), including, but not limited to, prone positioning of sleeping infants, soft bedding added to sleep areas, and gaps/pockets between mattresses and infant product sides.<sup>26 27 28</sup> Physiologically, infants experiencing a compromised airflow are likely to undergo a cycle of decreased heart and respiration rate, resulting eventually in fatal cessation of breathing. Numerous public awareness campaigns have aimed to educate caregivers regarding the identified hazards; these campaigns include: "Back to Sleep" (Moon *et al.*, 2016, as cited in Fors Marsh Group, 2019), the "ABC's of safe sleep" (alone (no bed sharing), back-sleeping, and crib uncluttered),<sup>29</sup> and "Safe Sleep/Bare is Best."<sup>30 31</sup> Health and safety advocates,

<sup>25</sup> Staff's NPR Briefing Package at Tabs C and E contain more detailed analysis of incidents and hazards associated with crib mattress use.

<sup>26</sup> The Centers for Disease Control and Prevention (CDC) defines "SUID" as the sudden and unexpected death of a baby less than 1-year-old, in which the cause was not obvious before investigation. See [https://www.cdc.gov/sids/about/index.htm?CDC\\_AA\\_refVal=https%3A%2F%2Fwww.cdc.gov%2Fsids%2FAboutSUIDandSIDS.htm](https://www.cdc.gov/sids/about/index.htm?CDC_AA_refVal=https%3A%2F%2Fwww.cdc.gov%2Fsids%2FAboutSUIDandSIDS.htm); accessed July 20, 2020.

<sup>27</sup> The American Academy of Pediatrics (AAP, 2016) explains that SUID, also known as "sudden unexpected death in infancy" (SUDI), includes explained and unexplained deaths, and it can be attributed to suffocation, asphyxia, entrapment, infection, ingestions, metabolic diseases, arrhythmia-associated cardiac channelopathies, and trauma. See <https://pediatrics.aappublications.org/content/pediatrics/138/5/e20162938.full.pdf>; accessed May 5, 2020.

<sup>28</sup> Sudden infant death syndrome (SIDS) is a subcategory of SUID that refers to infant deaths that cannot be explained after a thorough case investigation. The terms SUID and SIDS are used interchangeably, as SIDS commonly is used to refer to SUID in warning labels and articles and given that consumers are more familiar with the term SIDS as opposed to SUID.

<sup>29</sup> See <https://www.aappublications.org/news/2016/10/24/SIDS102416>; accessed May 7, 2020.

<sup>30</sup> See <https://www.cpsc.gov/Safety-Education/Neighborhood-Safety-Network/Posters/SAFE-SLEEP-for-Babies>; accessed May 6, 2020.

<sup>31</sup> See <https://www.cpsc.gov/safety-education/safety-guides/kids-and-babies-cribs/safe-sleep-bare-best> and <https://www.nationwidechildrens.org/family-resources-education/health-wellness-and-safety-resources/helping-hands/safe-sleep-practices-for-babies>; accessed May 11, 2020.

including the AAP, CDC,<sup>32</sup> CPSC, and Kids in Danger (KID)<sup>33</sup> support these efforts.

To make infant sleep environments more comfortable, caregivers commonly use soft bedding and after-market mattresses, instead of, or in addition to, an OEM mattress. Infants can maneuver themselves into vulnerable positions in a sleep environment, from which they cannot free themselves:

Infants in the age range associated with fatal incidents, *i.e.*, between 2 and 6 months, develop new skills, such as rolling over and crawling, in stages. According to Bayley (1969), several developmental milestones occur within the first 6 months of life; some notable motor skills typically achieved are turning from side to back (average age: 1.8 months old), turning from back to side (average age: 4.4 months old), and turning from back to stomach (average age: 6.4 months old). Children as young as 8 to 12 weeks are likely to move around a play yard, including moving to the edge and possibly moving into vulnerable situations. However, children may not be able to remove themselves by reversing their actions because they may not have developed the skill.<sup>34</sup>

Infants can become trapped in a gap between a crib mattress and the side wall(s) of their sleep environment, with their nose and mouth pressed against the mattress or side wall, experiencing compromised airflow. Gap entrapment is a hazard associated with ill-fitting mattresses in full-size cribs, play yards, and non-full-size cribs. To minimize the risk for entrapment in a gap, a full-size crib and full-size crib mattress that meet the applicable standards would allow a maximum side gap of 1 $\frac{3}{8}$  inches.<sup>35</sup> Given non-flexible sides and infant head dimensions,<sup>36</sup> requirements in these

<sup>32</sup> See <https://www.cdc.gov/vitalsigns/safesleep/index.html>; accessed May 2, 2020.

<sup>33</sup> See <https://kidsindanger.org/protect-your-child/sleep/>; accessed May 6, 2020.

<sup>34</sup> See page 5, [https://www.cpsc.gov/s3fs-public/Petition%20CP%2015-2%20-%20Petition%20Requesting%20Ban%20on%20Supplemental%20Mattress%20for%20Play%20Yards%20with%20Non-Rigid%20Sides%20-%20May%2010%20217\\_3.pdf](https://www.cpsc.gov/s3fs-public/Petition%20CP%2015-2%20-%20Petition%20Requesting%20Ban%20on%20Supplemental%20Mattress%20for%20Play%20Yards%20with%20Non-Rigid%20Sides%20-%20May%2010%20217_3.pdf); accessed September 14, 2020.

<sup>35</sup> Per 16 CFR part 1219, and by reference ASTM F1169-19, a full-size crib must have interior dimensions of 28  $\pm$   $\frac{3}{8}$  inches wide by 52 $\frac{3}{8}$   $\pm$   $\frac{5}{8}$  inches long. Per the existing voluntary standard for crib mattresses, ASTM F2933-19, a full-size crib mattress shall measure at least 27 $\frac{1}{4}$  inches wide by 51 $\frac{5}{8}$  inches long by 6 inches thick.

<sup>36</sup> According to Snyder (1975), the 5th percentile head breadth, *i.e.*, the maximum breadth of the head above and behind the ears, of children 0 to 3 months old is approximately 3 $\frac{3}{10}$  inches, which is more than twice as wide as the maximum allowable side gap between full-size cribs and full-size crib mattresses. ESHF staff selected head "breadth," as opposed to length or height, to err on the side of caution, as head breadth is the smallest of these three head dimensions that could cause a fatal entrapment. Similarly, staff selected the 5th percentile measurement for 0-to-3-month-old

standards work in tandem to help prevent head entrapment and suffocation between the mattress and crib sides, even though a full-size crib manufacturer is not required to provide the mattress.<sup>37</sup> Still, incidents of gap entrapment involving these products continue to occur, including when the full-size crib and *non-compressed* full-size crib mattress measure the appropriate dimensions. For example, gaps involving full-size crib mattresses can develop if the mattresses are too soft, such as when the mattress is compressed by mattress sheets.

Gaps between the infant's mattress and sleep product sides are especially hazardous when after-market mattresses with thicker depth dimensions than the OEM mattress are used in products with flexible (*e.g.*, mesh or fabric) sides, such as play yards and non-rigid-sided portable cribs. The side walls of these products typically expand more towards the center of the side wall, and,

consequently, as the thickness of mattresses used in these products increases, the risk of gap entrapment often increases as well.

*F. Product Recalls*<sup>38</sup>

From June 1, 2010 to June 1, 2020, CPSC negotiated five consumer-level recalls involving crib mattresses to mitigate against risks of flammability and suffocation. Four recalls involved non-compliance with mandatory federal flammability requirements. These four recalls included approximately 80,000 units in total. The Commission cannot provide an exact number of units because of a lack of differentiation between crib and adult mattress populations in recalls that included both. The fifth recall of crib mattresses involved a dimensional issue, where the crib mattress models were ill-fitting, presenting an entrapment hazard. This recall included approximately 300,000 units.

**IV. International Standards for Crib Mattresses**<sup>39</sup>

The Commission is aware of two international voluntary standards pertaining to crib mattresses:<sup>40</sup>

- BS EN 16890:2017—Children's Furniture—Mattresses for cots and cribs—Safety requirements and test methods (BS EN 16890); and
- Australian/New Zealand Standard 8811.1:2013—Methods of testing infant products (AS/NZS 8811.1).

Table 5 compares each of these international standards to ASTM F2933–19 to assess how each standard addresses the identified hazard patterns and other common hazards. Tab B of Staff's NPR Briefing Package contains a more detailed analysis of the comparison, and how each standard addresses the hazard patterns described in Table 5.

TABLE 5—COMPARISON OF CRIB MATTRESS VOLUNTARY STANDARDS BY HAZARD PATTERN

Hazard pattern	ASTM F2933	AS/NZS 8811.1	EN 16890	Comments
Chemical Hazards	16 CFR part 1303 Ban of Lead-Containing Paint, 16 CFR part 1500 Hazardous Substances Act Regulations.	Not addressed .....	Provision for specific controlled toxic substances.	ASTM is adequate to address US incident data.
Coil or Spring .....	Prohibition of sharp points .....	Not addressed .....	Prohibition of sharp points .....	NPR proposes addition of cyclic testing. ASTM more stringent.
Crib Mattress Used in a Play Yard.	Labeling requirements, requirements for after-market mattresses and required testing to ASTM F406 mattress requirements.	Not addressed .....	Labeling requirements .....	ASTM more stringent.
Expand or Inflate ...	Dimensional conformity, mattress thickness, and labeling requirements.	Not addressed .....	Dimensional conformity, labeling requirements.	ASTM more stringent.
Face in Mattress ....	Labeling requirements .....	Firmness test .....	Firmness test .....	NPR proposes mattress firmness test based on sections 6 and 8 of AS/NZS 8811.1 firmness test, in addition to label requirements in ASTM F2933–19.
Fit Issues .....	Dimensional conformity and after-market mattress requirements.	Not addressed .....	Dimensional conformity, conical probe test, cyclic test.	NPR proposes fitted sheet compression test.
Found Prone .....	Labeling requirements .....	Firmness test .....	Firmness test .....	NPR proposes mattress firmness test based on sections 6 and 8 of AS/NZS 8811.1 firmness test, in addition to label requirements in ASTM F2933–19.
Mattress Falls Apart	Mattress seam stitching requirement and small parts prohibition.	Not addressed .....	Mattress seam stitching requirement and small parts prohibition.	ASTM more stringent.
Softness .....	Not addressed .....	Firmness test .....	Firmness test .....	NPR proposes mattress firmness test based on sections 6 and 8 of AS/NZS 8811.1 firmness test.
Multiple Contributing Factors (MCF).	General requirements and instructional literature.	Not addressed .....	General requirements and instructional literature.	ASTM General Requirements are adequate but safety info is inadequate.
Small Parts .....	Prohibited per 16 CFR part 1501 .....	Not addressed .....	Same as ASTM .....	ASTM is adequate to address U.S. incident data.
Sharp Points/Edges	Prohibited per 16 CFR 1500 .....	Not addressed .....	Prohibited but no performance requirements.	ASTM is more stringent.
Flammability .....	Prohibited per 16 CFR 1632 and 1633	Not addressed .....	Must comply with EN 71–2:2011 and EN 597–1.	ASTM is adequate to address U.S. incident data.
Small Openings ....	Openings between 0.210" and 0.375" prohibited.	Not addressed .....	Not addressed .....	ASTM is adequate and more stringent.

infants to reduce the likelihood of death or serious injury to those most vulnerable to the identified hazards.

<sup>37</sup> See <https://www.cpsc.gov/Business-Manufacturing/Business-Education/Business->

*Guidance/Full-Size-Baby-Cribs/*, accessed May 1, 2020.

<sup>38</sup> See Staff's NPR Briefing Package at Tab D.

<sup>39</sup> See Staff's NPR Briefing Package at Tab B.

<sup>40</sup> The Commission is also aware of a draft, unpublished, standard, ISO 23767 *Children's*

*furniture—Mattresses for cots and cribs—Safety requirements and test methods*. Although this draft ISO standard is not yet an official standard, CPSC staff reviewed it for relevancy and found that it is nearly identical to BS EN 16890.



TABLE 5—COMPARISON OF CRIB MATTRESS VOLUNTARY STANDARDS BY HAZARD PATTERN—Continued

Hazard pattern	ASTM F2933	AS/NZS 8811.1	EN 16890	Comments
Label Permanency	Must not detach with <15-lb. pull force	Not addressed .....	Must not detach after 30 attempts to remove with feeler gauge.	ASTM is adequate and more stringent.
Dimensional Conformity.	Must be at least 27.25" x 51.625" during application of forces.	Not addressed .....	Must be within 10 mm of nominal dimensions.	ASTM is adequate and more stringent.
Entanglement .....	All accessible stitching must be lock stitching.	Not addressed .....	Maximum free length of 220 mm .....	ASTM is adequate to address U.S. incident data.
Seam Stitching .....	All accessible stitching must be lock stitching.	Not addressed .....	Seams must not be penetrated >6 mm with 12 mm diameter probe.	ASTM is adequate and more stringent.
After-Market Mattresses.	Mattresses shall have same thickness, floor support structure and attachment method as the mattress it is intended to replace.	Not addressed .....	Not addressed .....	ASTM is more stringent; NPR proposes to extend dimension requirements in 5.7.2 to all after-market non-full-size crib mattresses.
Warning Labels/Instructions.	Warning labels required, instructions not required.	Not addressed .....	Instructions required/warning labels do not address as many hazards.	ASTM is inadequate. See human factors assessment in Tab C of Staff's NPR Briefing Package.

With the exception of mattress firmness, the Commission concludes that ASTM F2933–19 is equivalent to, or more stringent than, AS/NZS 8811.1 or EN 16890 because it more fully addresses the hazard patterns identified by CPSC staff in the reported incident data. Compared to these international standards, ASTM F2933–19 is more comprehensive because it also addresses non-full-size crib mattresses and after-market mattresses for play yards and non-full-size cribs. Furthermore, the Commission notes that ASTM F2933–19 was developed through collaboration between CPSC staff and stakeholders, and has been revised three times in the attempt to address incident data provided by CPSC staff. Therefore, the Commission concludes that ASTM F2933–19, when modified to include a test for mattress firmness based on sections 6 and 8 of AS/NZS 8811.1:2013, is more appropriate than AS/NZS 8811.1:2013 or EN 16890 to address hazard patterns associated with crib mattresses.

**V. Voluntary Standard—ASTM F2933**<sup>41</sup>

*A. History of ASTM F2933*

The ASTM Committee F15 on Consumer Products first published the voluntary standard for crib mattresses in 2013, as ASTM F2933–13, *Standard Consumer Safety Specification for Crib Mattresses*. The first publication established requirements for the standard and addressed the following issues:

- Sharp points and sharp edges,<sup>42</sup>
- Small parts,
- Lead and other toxic substances in paints,
- Finger entrapment,

<sup>41</sup> See Staff's NPR Briefing Package at Tab B for additional information about the history and performance requirements in ASTM F2933–19.

<sup>42</sup> Tapered ends that do not meet the requirements of 16 CFR 1500.48 and metal or glass tapered surfaces that do not meet the requirements of 16 CFR 1500.49.

- Mattress dimension conformity,
- Mattress thickness, and
- Marking and labeling.

Since 2013, ASTM has revised and updated the voluntary standard three times to address safety issues, as outlined below:

*ASTM F2933–16 (approved 12/1/2016):*

- Revised warning label permanency requirements in 5.6.1, to include requirement that “[n]on-coated paper warning label shall not be applied on either side of sleeping surface.” Added a note under this section, stating that non-coated paper label may absorb water and can deteriorate.

*ASTM F2933–18 (approved 8/15/2018):*

- Revised scope to include a new section 1.5, stating the standard was developed in accordance with internationally recognized principles on standardization.
- Added definition of “after-market mattress for play yard or non-full-size crib,” to section 3, Terminology.
- Added a new requirement for after-market mattresses for play yards and non-full-size crib mattresses in section 5, General Requirements, stating that after-market mattresses for soft-sided and non-rectangular, rigid-sided products shall have the same thickness, floor support structure, and attachment method as the mattress it is intended to replace and shall meet the specifications of Mattress Vertical Displacement test from ASTM F406–19, *Standard Consumer Safety Specification for Non-Full-Size Baby Cribs/Play Yards*.

Added additional marking and labeling requirements for after-market mattresses in sections 7.5 through 7.7. To comply with these sections, after-market mattresses and their retail packaging shall include specified suffocation warning language related to hazardous gaps and stacked mattresses. Sections 7.5 and 7.6 have additional requirements that distinguish between

types of products. Section 7.5 has requirements specific to mesh/fabric-sided and rigid-sided, non-rectangular products, including as follows: After-market mattresses shall have all the warnings that the original manufacturer had and provide instructions that are on the original mattress, and both the after-market mattress and the retail packaging shall identify the brand and model numbers of products in which it is intended to be used. Section 7.6 contains requirements specific to rigid sided rectangular products including as follows: After-market mattresses and their retail packaging shall have a specified statement regarding mattress dimensions and fit.

*ASTM F2933–19 (approved 6/15/2019):*

- Added a new requirement for mattress seam stitching in section 5, General Requirements, requiring that all seam stitching that is accessible to the occupant be lock stitching.

*B. Description of Performance Requirements in ASTM F2933–19*

In addition to the general requirements typically found in other ASTM juvenile product standards, such as requirements for openings, label permanency, and the prohibition of sharp points/edges, small parts, and lead in paints, section 5 of ASTM F2933–19 contains the following four additional requirements that apply specifically to mattresses for cribs, non-full-size-cribs, and to after-market mattresses for non-full-size cribs and play yards:

- *§ 5.7 Mattress Dimensions:* Describes the dimensional requirements for full-size mattresses and OEM non-full-size crib mattresses, to prevent an infant from becoming wedged in a gap caused by a too small crib mattress. To ensure the crib mattress dimensions are within the allowable range, the test requires a mattress to be placed in a test box and pushed against the side of the

box with a force prescribed in the test method.

- **§ 5.7.2.2 Mattress Thickness:** Applies to OEM non-full-size crib mattresses, to prevent occupants from falling out of the product. The requirement states that a mattress supplied with a non-full-size crib shall have a thickness that will provide a minimum effective crib-side height dimension of at least 20 inches when the crib side is in its highest adjustable position and the mattress support is in its lowest adjustable position. Additionally, the mattress shall have a thickness that will provide a minimum effective crib-side height dimension of at least 3 inches when the crib side is in its lowest adjustable position, and the mattress support is in its highest adjustable position.

- **§ 5.8 Mattress Seam Stitching:** Applies to all crib mattresses within the scope of the standard, and requires that all seam stitching that is accessible to the occupant be lock stitching to prevent accessible stitching from becoming loose and creating a small part or strangulation hazard.

- **§ 5.9 After-Market Mattress for Play Yards and Non-Full-Size Cribs:** Applies to after-market mattresses for

play yards and non-full-size cribs, and requires that mesh/fabric sided products, and rigid sided non-rectangular products, must have the same thickness, floor support structure, and attachment method as the mattress it is intended to replace. Accordingly, after-market mattresses for play yards and non-rectangular rigid sided products must be identical to the OEM mattress.<sup>43</sup> After-market mattresses must also meet the Mattress Vertical Displacement test in ASTM F406.<sup>44</sup> Finally, section 5.9.1.3 requires “replacement” mattresses intended to be used in the bassinet of a play yard with a bassinet attachment to meet the requirements of ASTM F2194, when tested with each brand and model the mattress is intended to replace.

**VI. Assessment of the Voluntary Standard ASTM F2933–19**

*A. Adequacy of Performance Requirements*<sup>45</sup>

ASTM developed ASTM F2933 to mitigate the risk of injury associated with the use of crib mattresses. Hazard mitigation strategies include performance requirements and instructions and on-product warnings to

help inform caretakers of the primary hazards during use of the product. Based on CPSC staff’s Engineering, Human Factors, and Health Sciences assessments, Tabs B, C, and E of Staff’s NPR Briefing Package, respectively, the requirements in the current voluntary standard, ASTM F2933–19, adequately address the hazard patterns related to expanding or inflating crib mattresses, mattresses falling apart, and most hazards associated with multiple contributing factors, or other hazards. However, ASTM F2933–19 does not adequately address the most prevalent or severe identified hazards associated with the use of crib mattresses, such as coil spring issues, face in mattress, fit issues, found prone, and softness. The warning labeling for factors within multiple contributing factors (such as, face in mattress, found prone, and softness) are also inadequate. Accordingly, the Commission proposes additional requirements in the NPR to make the standard more stringent, to further reduce the risks of death and injury from these hazard patterns. Table 6 summarizes CPSC’s assessment of the adequacy of ASTM F2933–19 to address the identified hazard patterns.

**TABLE 6—ADEQUACY OF ASTM F2933–19 IN ADDRESSING IDENTIFIED HAZARD PATTERNS**

Identified hazard pattern (potential injury)	Applicable mattresses	How addressed in ASTM F2933–19	Adequacy	Comments
Chemical/Flammability Hazards (odors, rash).	All .....	16 CFR part 1303—Lead-Containing Paint; 16 CFR part 1500—Hazardous Substances Act Regulations (Sections 5.1 and 5.4); 16 CFR part 1632—Flammability of Mattresses and Mattress Pads; 16 CFR part 1633—Flammability (Open Flame) of Mattress Sets.	Adequate .....	Staff’s NPR Briefing Package (SBP) Tab B.
Coil or Spring (laceration) .....	Coil or spring mattresses (primarily full-size).	Prohibition of sharp points (Section 5.2).	Inadequate .....	Propose additional cyclic testing to identify potential for springs to break through surface during foreseeable use and misuse. SBP Tab B.
Crib Mattress Used in a Play Yard (suffocation due to ill-fitting mattress).	Aftermarket play yard mattresses.	Labeling requirements, requirements for after-market mattresses. Testing requirements harmonized with ASTM F406. (Section 7.5).	Adequate .....	SBP Tabs B & C.
Expand or Inflate (suffocation due to ill-fitting mattress that does not expand or inflate properly).	Foam products, typically full-size and shipped as “bed in a box”.	Dimensional conformity, mattress thickness, and labeling requirements (Section 5.7).	Adequate .....	SBP Tab B.
Face in Mattress (suffocation) .....	All .....	Labeling requirements (Section 7.3) ....	Inadequate .....	NPR proposes a test based on sections 6 and 8 of AS/NZS 8811.1 firmness test. SBP Tabs B & C.
Fit Issues (suffocation due to ill-fitting mattress).	All .....	Dimensional conformity and after-market mattress requirements (Sections 5.7 and 5.9).	Inadequate .....	NPR proposes additional fitted sheet compression test for full-size crib mattresses and extending dimensional requirements in section 5.7 to all after-market, non-full-size crib mattresses. SBP Tab B.

<sup>43</sup> Requirements for OEM mattresses sold with play yards and non-full-size cribs are codified at 16 CFR parts 1220 (non-full-size cribs) and 1221 (play yards), which incorporate by reference ASTM F406, *Standard Consumer Safety Specification for Non-Full-Size Baby Cribs/Play Yards* (ASTM F406).

<sup>44</sup> The purpose of requiring after-market mattresses to be identical to OEM mattresses is to reduce the risk of infant entrapment and suffocation associated with after-market mattresses that are too thick, or that do not fit correctly or attach to a play yard or non-full-size crib. ASTM developed this requirement in collaboration with CPSC staff and

the ASTM Play Yard Vertical Displacement Task Group and the Play Yard Mattress Fit and Thickness Task Group.

<sup>45</sup> Staff’s NPR Briefing Package at Tab B contains additional details on the CPSC staff’s analysis of ASTM F2933–19 and its ability to address identified hazards.

TABLE 6—ADEQUACY OF ASTM F2933–19 IN ADDRESSING IDENTIFIED HAZARD PATTERNS—Continued

Identified hazard pattern (potential injury)	Applicable mattresses	How addressed in ASTM F2933–19	Adequacy	Comments
Found Prone (suffocation due to prone position).	All .....	Labeling requirements (Section 7.3) ....	Inadequate .....	Propose additional mattress firmness test based on sections 6 and 8 of AS/NZS 8811.1 and strengthening warning label requirements. SBP Tabs B & C.
Mattress Falls Apart (choking/ingestion)	All .....	Mattress seam stitching requirement and small parts prohibition (Sections 5.3 and 5.8).	Adequate .....	SBP Tab B.
Softness (suffocation due to soft surface).	All .....	Not addressed .....	Inadequate .....	Propose additional mattress firmness test based on sections 6 and 8 of AS/NZS 8811.1 firmness test. SBP Tab B.
Multiple Contributing Factors (MCFs, e.g., entrapment in bumper pads, limb entrapment, crib sharing with another infant, existing health condition).	All .....	General requirements and warning labels (Sections 5.7 and 7.3).	Inadequate .....	Some MCFs addressed by proposed additional requirements, while others are related to another product use or other factor out of the scope of the crib mattresses standard.

1. Coil or Spring Lacerations

Laceration hazards due to an exposed coil or spring accounted for 124 of the 440 incident reports (38% of nonfatal incidents). Currently, ASTM F2933–19 does not address this hazard. A cyclic test could address this hazard, by loading and unloading any mattress that contains coils or springs for a set number of cycles, to exercise metal coil springs and identify springs that cannot withstand normal use without breaking, or that may otherwise break the surface of the mattress.

In July 2018, the ASTM Crib Mattress Cyclic Testing task group discussed a cyclic impact test based on the Mattress Support Vertical Impact Test from section 7.4 of ASTM F1169–19 (the standard for full-size cribs). At the F15.66 Crib Mattress subcommittee meeting held in October 2018, the subcommittee discussed both the Mattress Support Vertical Impact Test and the Mattress Durability Roller Testing for spring/coil mattresses, based on ASTM F1566, *Standard Test Methods for Evaluation of Innersprings, Boxsprings, Mattresses or Mattress Sets*, section 7, as possible cycle loading tests. In the following months, CPSC staff and other members of the Crib Mattress Cyclic Testing task group performed variations of the Mattress Support Vertical Impact Test to determine a test that would be most applicable to crib mattresses with coil springs.

On April 29, 2019, CPSC staff sent a letter to the subcommittee chair in response to ballot F15 (19–04), stating staff’s initial test results. In the task group meeting in July 2019, staff and one manufacturer discussed the results of their continued testing and refined the requirements. The task group focused testing on the Mattress Support Vertical Impact Test because this test uses the same equipment employed in

full-size crib testing. After replicating the full-size crib impact test (45 pounds dropped 750 times), staff assessed that the test was too onerous. During task group discussions, consensus was to lower the weight to 30 pounds and increase the number of cycles to 1,000.

ASTM has not held additional task group meetings or issued ballots on this issue since the July 2019 task group meeting. The Commission’s proposed requirement in the NPR to address coils and springs is based on the last work of the task group, and the test requires a 30-pound impactor drop, similar to the full-size crib standard, on a mattress in four specified locations for a total of 1000 impacts. Tab B of Staff’s NPR Briefing Package provides additional details of staff’s work to address coil and spring lacerations and the proposed cyclic test.

2. Fit Issues

Fit issues are associated with 108 of 439 incidents; 20 were fatal, and 88 were nonfatal. In these reports, gaps between the crib mattress and the crib rail or play yard mesh, on one or more areas around the perimeter of a crib mattress, created a wedging or entrapment hazard. Reports of mattresses that fail to expand, compress, or buckle, indicate the potential to form hazardous gaps between the corner of a crib and the corner of the mattress. This hazard can arise when a fitted sheet is placed on the mattress, creating large corner gaps that could lead to entrapment. Fit issues can also occur when a mattress is not dimensionally appropriate for use with a specific crib.

a. Mattress Compression With Fitted Sheet

ASTM F2933–19 contains a mattress dimensional conformity test intended to address hazardous gaps between the edge of a crib and the mattress.

However, staff testing found that tight-fitting sheets over crib mattresses can create gaps between the corners of the mattress and the interior corner of the crib, creating an entrapment hazard. ASTM F2933–19 does not adequately address this mattress compression issue that creates an entrapment hazard between a full-size crib mattress and the side or corner of a full-size crib.

For further examination, staff obtained 11 full-size crib mattresses and eight 100 percent cotton full-size crib mattress sheets to investigate this reported hazard pattern. Staff washed four sets of sheets twice in hot water then dried them at the highest temperature setting; staff did not wash the remaining four sheet sets. Staff measured the length and width of two corner seams of the eight mattress sheets with the corner seams straightened. Staff measured length and width by holding the innermost ends of two adjacent corner seams, separating them until a straight edge was formed, and measuring the straight edge.

Staff set aside for mattress testing the smallest sheet of each group, as determined by the smallest length and width dimensions. The sheets were then fitted on the mattresses to determine the change in dimensions and whether any potentially hazardous gaps were created. Staff shared the test results, detailed in Tab B of Staff’s NPR Briefing Package, with the subcommittee chair on March 20, 2020, but no ASTM subcommittee or task group meetings for crib mattresses have occurred since then, due to the COVID–19 pandemic. To strengthen the standard, the Commission proposes in the NPR to add a test for full-size mattresses to assess compression and fit issues caused by a tight-fitting sheet. This additional test may also help with complaints around mattresses inflating or expanding,

because the proposed test would repeat the dimensional conformity test.

b. Dimension Requirements for After-Market Non-Full-Size Crib Mattresses

ASTM F2933–19 addresses dimensional requirements for non-full-size crib mattresses in two places: Section 5.7, which addresses mattresses

“supplied with” a non-full-size crib (OEM mattresses), and section 5.9, which addresses after-market mattresses for non-full-size cribs (mattresses purchased separately from a crib, which are not intended by the OEM as a replacement mattress). Dimensional requirements for non-full-size crib mattresses are a key requirement in

ASTM F2933–19, because size requirements prevent hazardous gaps from forming between the edge of a mattress and the side of the crib, where infants can become entrapped and suffocate. Table 7 presents the types of crib mattresses covered by ASTM F2933 and the current dimensional requirements for each mattress type.

TABLE 7—CURRENT PERFORMANCE REQUIREMENTS FOR CRIB MATTRESS DIMENSIONS

		ASTM F2933–19	16 CFR 1221 ASTM F406	16 CFR 1220 ASTM F406	ASTM F2933–19	ASTM F2933–19
		Crib mattresses	Play yards	Non-full-size cribs	Crib mattresses	Crib mattresses
		5.7.1.1	5.16.2	5.17	5.7.2	5.9.1
Full-Size	All	X				
Play Yards	Original*		X			X**
	After-market					
Rectangular NFS	Original*			X	X	
	After-market					
Non-Rectangular NFS	Original*			X	X	X*
	After-market					

\* Includes “replacement mattresses,” which are assumed to be sold by an original equipment manufacturer (OEM) and equivalent in dimension and specification to the original mattress (see ASTM F2933–19 section 3.1.1.1).

\*\* After-market play yard mattresses that are also used in a bassinet attachment to that play yard must also meet ASTM F2194, for bassinets.

Table 7 demonstrates a gap in the dimensional requirements for after-market, rectangular-shaped, non-full-size crib mattresses in section 5.9 ASTM F2933–19 (shaded), which does not appear to have a performance requirement for mattress dimension. The Commission proposes in the NPR to address this gap by expanding the non-full-size crib mattress requirements in 5.7.2, which currently only apply to OEM mattresses, to apply to all non-full-size crib mattresses.

Although the after-market requirements in section 5.9 are purportedly intended to apply to “After-market mattress for play yard and non-full size crib,” the requirements in section 5.9.1 are limited to “mesh/fabric sided products” (meaning play yards) and “rigid sided non-rectangular products” (meaning non-rectangular non-full-size cribs). Because section 5.7 of ASTM F2933–19 only applies to OEM mattresses, no performance requirements in the standard apply to after-market, rectangular-shaped, non-full-size crib mattresses. CPSC staff reviewed the rationales for changes to the after-market requirements for crib mattresses in the ASTM standards, and notes that the ASTM intentionally limited performance requirements in section 5.9.1 by omitting rectangular mattresses for rigid-sided products (i.e., rectangular non-full-size cribs). Staff reviewed ASTM minutes and ballot F15 (17–02), which implemented this requirement in F2933; however, staff

could not determine the rationale for limiting the requirements to only *non-rectangular* products.

Although ASTM F2933–19 contains no dimension requirements for after-market, rectangular-shaped, non-full-size crib mattresses, the standard does contain warning requirements pertaining to the size of after-market mattresses for rectangular non-full-size cribs. Staff’s NPR Briefing Package details these warnings requirements in section 7 of ASTM F2933–19. Generally, solely relying on a warning label puts the onus on the consumer to read, understand, and follow the direction to only use an OEM mattress. CPSC staff concluded that warnings alone are insufficient to address the hazards associated with ill-fitting, after-market, non-full-size crib mattresses.

3. Found Prone, Face Into Mattress, and Softness

CPSC staff separated the hazard patterns for found prone, face into mattress, and softness in the incident review, as reflected in Table 6. However, due to available details in each incident, CPSC staff considers these hazard patterns to be related. Accordingly, the Commission’s proposed modifications in the NPR related to each of these hazard patterns may address incidents associated with all three hazard patterns.

Staff found that in 57 percent (66 out of 116) of the reported fatalities and three reported nonfatal incidents (1%),

the infant was found in a prone position (face down) with no mention of whether the face of the child was in contact with the crib mattress or crib sheet, and no mention of whether the face was obstructed by other crib bedding or other items in the sleep environment. However, in 11 percent (13 out of 116) of fatalities, when discovered, the child was found prone and the report specifically indicated the face of the child was in contact with a crib mattress or crib sheet covering the crib mattress. Based on the available information about each fatality, staff found that some reports indicate that bedding was present in the sleeping environment, but bedding was not touching the infant or did not appear to be a contributing factor in the death. Additionally, staff found that in 11 percent (36 out of 323) of the nonfatal incidents, the report stated that a crib mattress inner cushioning was too soft. Although these incidents did not involve a fatality, soft bedding, such as pillows and comforters, is associated with infant fatalities, and staff deduces that an excessively soft mattress (i.e., one that may mold around or otherwise occlude an infant’s airway), such as mattresses made of memory foam,<sup>46</sup> could present the same hazard.

Pillows, and other soft, pillow-like objects can pose a suffocation hazard to

<sup>46</sup> Memory foam is a viscoelastic-foam product that is sensitive to pressure and temperature and intended to conform to the body.

infants by conforming to the face and blocking the nose and mouth. A crib mattress must be sufficiently firm to prevent a child's nose and mouth from being obstructed by a mattress that is too soft and pillow-like. Prone positioning is a known risk factor for SUID, and may be related to limited physical and developmental capabilities of infants, who may not arouse themselves in a low-oxygen situation. Suffocation-type asphyxial deaths (e.g., smothering) involve occlusion of airways and can occur when an infant is placed to sleep or rolls into a prone position on a surface capable of conforming to the body or face of an infant, such that the mouth and nose are physically blocked, preventing air passage. Moreover, published guidance from the American Academy of Pediatrics (AAP) states: "A soft sleeping surface (e.g., memory foam) can increase the risk of rebreathing or suffocation"<sup>47</sup>; and "Soft mattresses, including those made from memory foam, could create a pocket (or indentation) and increase the chance of rebreathing or suffocation if the infant is placed in or rolls over to the prone position."<sup>48</sup> Tab E of Staff's NPR Briefing Package contains additional information about the suffocation hazard.

Other than through warnings, ASTM F2933–19 does not address mattress firmness or softness hazards potentially related to prone and face into mattress incidents. ASTM F2933–19 contains warning requirements regarding prone positioning; however, based on CPSC staff's analysis, warnings alone are inadequate to address the suffocation hazard. The Commission proposes in the NPR a performance requirement to measure mattress firmness, to address some prone-positioning deaths<sup>49</sup>—in which it was not clear that that face was *in* the mattress. In a letter to the ASTM subcommittee chair for crib mattresses, dated December 11, 2019, staff recommended that the subcommittee continue their previous work on mattress firmness. The firmness task group met on January 8, 2020, to discuss this recommendation. In a task group meeting held on February 13, 2020, staff verbally shared the results of staff's testing to AS/NZS 8811.1:2013 and a

<sup>47</sup> <https://www.aafp.org/afp/2017/0615/p806.html>.

<sup>48</sup> <https://pediatrics.aappublications.org/content/138/5/e20162938#ref-19>.

<sup>49</sup> Many factors contribute to prone positioning deaths, and suffocation face down in a soft mattress is just one possible factor. Staff could not definitively associate soft mattresses with specific incidents. However, staff did not associate incidents with firm mattresses, and staff is aware of deaths associated with other products with conforming surfaces (e.g., pillows, blankets).

draft test method in ISO/CD 23767, although most members had yet to perform any testing. Staff also shared testing results in a letter to the subcommittee and task group chair on March 20, 2020. The task group planned to discuss CPSC testing results at the April subcommittee meeting, which was canceled due to the COVID–19 pandemic. CPSC staff's testing, detailed in Tab B of Staff's NPR Briefing Package, found few failures with either test method, based on 11 sample mattresses available from big box retail stores.

After evaluating the hazards associated with soft surfaces, the Commission proposes in the NPR additional performance requirements to make the standard more stringent, to further reduce the risk of death and injury associated with mattresses that are too soft and have the ability to conform to an infant's face. Although the warning label change and the firmness test will not make prone sleeping safe, they may help to reduce the instances in which an infant maneuvers into a prone position with its face *in* the mattress that could have been mitigated with a firmer surface. CPSC staff determined that the AS/NZS 8811.1:2103 is more repeatable and more stringent than the draft test in ISO/CD 23767. Accordingly, the Commission proposes a mattress firmness test in the NPR for all crib mattresses within the scope of the standard that is based on sections 6 and 8 of AS/NZS 8811.1:2013.<sup>50</sup> Tab B of Staff's NPR Briefing Package contains additional details regarding staff's testing of mattress firmness and the rationale for recommending the addition of the performance test based on AS/NZS 8811.1:2013.

#### *B. Adequacy of Marking, Labeling, and Instructions*<sup>51</sup>

Universally, labeling experts view warning about a hazard as less effective at addressing hazards than either designing the hazard out of a product, or guarding the consumer from the hazard. The use of warnings is lower in the hazard-control hierarchy than

<sup>50</sup> Staff also used a test based on AS/NZS 8811.1:2013 to address a smothering-type suffocation hazard presented by crib bumpers separating from the crib or otherwise protruding into the sleep area and getting underneath an infant. In these situations, the crib bumper behaves like a quilt or soft bedding that is able to conform to, and occlude, airway openings. Extending the requirement to the mattress will similarly reduce the risk of suffocation posed by soft depressions or indentations in crib mattresses.

<sup>51</sup> Staff's NPR Briefing Package at Tab F contains additional details on the basis for the Commission's proposed modifications to the marking, labeling, and instructional literature requirements for crib mattresses.

design-based approaches because the effectiveness depends on persuading consumers to alter their behavior in some way to avoid hazards, rather than eliminating hazards or inhibiting exposure to hazards. Therefore, when a standard relies on warnings to address a hazard, warning statements must be as strong as possible; *i.e.*, the warnings must be noticeable, understandable, and motivating. The primary U.S. voluntary consensus standard for product safety signs and labels, ANSI Z535.4, *American National Standard for Product Safety Signs and Labels*, recommends that on-product warnings include content that addresses the following three elements:<sup>52</sup>

- A description of the hazard;
- information about the consequences of exposure to the hazard; and
- instructions regarding appropriate hazard-avoidance behaviors.

Section 7 of ASTM F2933–19 specifies requirements for marking and labeling for full-size crib mattresses, non-full-size crib mattresses, and after-market mattresses for play yards and non-full-size cribs. Based on CPSC staff's examination of literature, incident data, and consumer feedback, the crib mattress warnings specified in ASTM F2933–19 do not adequately address these warning elements regarding the identified hazards. While there are warnings pertaining to infant positioning, soft bedding, and gap entrapment, the wording and formatting of the warning message needs to be improved to communicate the hazards effectively. Below we summarize the relevant warnings in ASTM F2933–19 and the Commission's concerns with the warnings.

#### 1. Warnings Regarding Infant Positioning

Regarding positioning babies on their backs to sleep, ASTM F2933–19 requires the following warning:

Failure to follow these warnings could result in serious injury or death. To prevent deaths, the U.S. Consumer Product Safety Commission (CPSC), the American Academy of Pediatrics (AAP), and the National Institute of Child Health and Human Development (NICHD) recommend the following:

To reduce the risk of Sudden Infant Death Syndrome (SIDS) and suffocation, pediatricians recommend healthy infants be placed on their backs to sleep, unless otherwise advised by your physician.

The warning to place babies on their backs to sleep includes, and is

<sup>52</sup> All three elements may not be necessary in some cases, such as if certain information is open and obvious or can be readily inferred by consumers. However, people often overestimate the obviousness of such information to consumers.

presented after, a significant amount of unnecessary text. Given that at least 102 of the 116 deaths involved prone positioning, many of which indicated no other known contributing factors, it is imperative that this warning be as clear and direct as possible. As discussed in Tab C of Staff's NPR Briefing Package, and the Appendix to Tab C, the Commission proposes in the NPR to modify this warning statement and its position on the warning label to increase the likelihood of consumers reading and understanding the hazard of prone sleeping.

## 2. Warnings Regarding Soft Bedding

Regarding soft bedding, ASTM F2933–19 includes the following warnings:

- Infants can suffocate on soft bedding. Never place a pillow or comforter under sleeping infant for additional padding or as a mattress substitute.

- Do not cover the heads of babies with a blanket or over bundle them in clothing and blankets. Overheating can lead to SIDS.

- [For full-size crib mattresses] Only use sheets and mattress pads designed specifically for crib mattresses.

- [For non-full-size crib mattresses] Only use sheets and mattress pads designed specifically for this mattress size.

Staff's review indicates that unnecessary wording is included in the warnings pertaining to soft bedding, and that the warnings are not clearly organized. Reports for at least 49 incidents indicate that caregivers added soft bedding to the sleep area, and survey<sup>53</sup> and focus group<sup>54</sup> feedback demonstrates that consumers commonly use soft bedding in infant sleep areas. As advocated in numerous public awareness campaigns by health and safety professionals, warnings regarding soft bedding must be communicated effectively. The Commission proposes to modify the warning content and formatting to

<sup>53</sup> See section ILC of this preamble for information about the DNPES.

<sup>54</sup> The 2019 "Consumer Product Safety Commission (CPSC): Caregiver Perceptions and Reactions to Safety Messaging Final Report," by Fors Marsh Group, includes a discussion of feedback from parents and grandparents who participated in focus groups pertaining to safe sleep practices. See Staff's NPR Briefing Package at Tab C for more information.

increase the readability and directness of the warnings.

## 3. Warnings Regarding Gaps

Regarding gaps, in addition to specifying consumers use only sheets and mattress pads designed for the crib mattress, ASTM F2933–19 includes the following warnings:

- [For full-size crib mattresses] Do not use this mattress in a crib having interior dimensions that exceed 28<sup>5</sup>/<sub>8</sub> by 53 in. (73 by 135 cm) as measured from the innermost surfaces of the crib.

- [For non-full-size rigid sided rectangular products] Check for proper fit of the mattress. This mattress measures \_\_\_\_\_ long, \_\_\_\_\_ wide, and \_\_\_\_\_ thick when measured from seam to seam. (The blank is to be filled in.)

- [For play yards and non-full-size cribs] Suffocation hazard: Babies have suffocated:

- In gaps between wrong-size mattress and side walls of product.

- Between the side walls and extra padding, such as stacked mattresses.

ALWAYS check mattress fit by pushing mattress tight to one corner. Look for any gaps between the mattress and the side walls. If this gap is larger than 1 in., the mattress does not fit and should NOT be used.

NEVER stack with another mattress. Use only ONE mattress.

For full-size crib mattresses, staff's review shows that these warnings do not provide consumers with enough information about the gap entrapment hazard. Reports for at least 14 of the cases resulting in death describe gaps involving a full-size crib mattress (at least 119 incident reports including complaints with and without injuries). Regarding this hazard, the warnings in ASTM F2933–19 inform consumers that only the full-size crib mattress is to be used in a crib with the specified dimensions (full-size crib dimensions in compliance with 16 CFR part 1219), and that consumers are to use only sheets and mattress pads designed specifically for crib mattresses. A single statement about specified dimensions is not sufficient, given the prevalence of this hazard and that factors such as rounded edges and compression can increase the size of side wall or corner gaps. The Commission proposes to modify these warnings to present more clearly and accurately the hazard information,

including the hazard information for full-size crib mattresses.

## 4. Additional Concerns Regarding the Warnings

The Commission has additional concerns with the safety information requirements in ASTM F2933–19, which undercut the effectiveness of the communication of the identified hazards. These concerns include, but are not limited to, the following:

- The definition of "conspicuous" in section 3 is ambiguous;

- the warning labels do not have a clear and comprehensive hazard identifier;

- the packaging requirements for marking and labeling are limited and exclude full-size crib mattresses;

- there are no requirements for warnings in instructional literature;

- the warning message includes a significant amount of superfluous text, resulting consequently in warning labels that are more difficult to understand and less likely to be read in their entirety; and

- the requirements in section 7 are worded and organized poorly, which may lead to confusion among manufacturers, test labs, and others viewing the standard.

The Commission proposes in the NPR to improve the requirements for safety information in ASTM F2933–19 to address the above concerns and further reduce the risk of injury and death from the identified hazards. In a side-by-side redline of the current and proposed labeling provisions in the Appendix to Tab C of Staff's NPR Briefing Package, staff identifies the specific weaknesses of ASTM F2933–19 for addressing the hazards, and provides explanations for the proposed modifications.

## 5. Basis for NPR Proposed Modifications to Safety Information

The Commission proposes in the NPR substantial modifications to the requirements for marking and labeling specified in ASTM F2933–19, including a new section on instructional literature. Figure 1 shows a comparison of full-size crib mattress warning labels compliant with ASTM F2933–19 current requirements versus the NPR's proposed labeling requirements.

**BILLING CODE 6355-01-P**

Current warning in ASTM F2933-19	Proposed NPR warning
<p style="text-align: center;"><b>⚠ WARNING</b></p> <p>Failure to follow these warnings could result in serious injury or death.</p> <p>To prevent deaths, the U.S. Consumer Product Safety Commission (CPSC), the American Academy of Pediatrics (AAP), and the National Institute of Child Health and Human Development (NICHD) recommend the following:</p> <p>To reduce the risk of Sudden Infant Death Syndrome (SIDS) and suffocation, pediatricians recommend healthy infants be placed on their backs to sleep, unless otherwise advised by your physician.</p> <ul style="list-style-type: none"> <li>• Infants can suffocate on soft bedding. Never place a pillow or comforter under sleeping infant for additional padding or as a mattress substitute.</li> <li>• Do not cover the heads of babies with a blanket or over bundle them in clothing and blankets. Overheating can lead to SIDS.</li> <li>• Do not use this mattress in a crib having interior dimensions that exceed 28<math>\frac{5}{8}</math> by 53 in. (73 by 135 cm) as measured from the innermost surfaces of the crib.</li> <li>• Only use sheets and mattress pads designed specifically for crib mattresses.</li> </ul> <p>DO NOT remove these important safety instructions.</p>	<p style="text-align: center;"><b>⚠ WARNING</b></p> <p><b>SIDS AND SUFFOCATION HAZARDS</b></p> <p><b>ALWAYS</b> place baby on back to sleep to reduce the risks of SIDS and suffocation.</p> <p><b>Babies have suffocated:</b></p> <ul style="list-style-type: none"> <li>• on pillows, comforters, and extra padding</li> <li>• in gaps between a wrong-size mattress, or extra padding, and side walls of product.</li> </ul> <p><b>NEVER</b> add soft bedding, padding, or an extra mattress.</p> <p><b>USE ONLY</b> one mattress at a time.</p> <p><b>DO NOT</b> cover the faces or heads of babies with a blanket or over-bundle them. Overheating can increase the risk of SIDS.</p> <p><b>ALWAYS</b> check mattress fit <b>every time you change the sheets</b>, by pushing mattress tight to one corner. Look for any gaps between the mattress and the side walls. If a gap is larger than 1<math>\frac{3}{8}</math> in. (3.5 cm), the mattress does not fit – <b>do not</b> use it.</p> <p><b>DO NOT</b> use this mattress in a crib having interior dimensions that exceed 28<math>\frac{5}{8}</math> by 53 in. (73 by 135 cm) as measured from the innermost surfaces of the crib.</p> <p><b>USE ONLY</b> sheets and mattress pads designed specifically for crib mattresses.</p> <p><b>DO NOT</b> remove these important safety warnings.</p>

**Figure 1. Current (left) and proposed (right) example warning labels for full-size crib mattresses.**

These labels are not shown in actual size.

**BILLING CODE 6355-01-C**

Proposed modifications to safety information in the NPR consider improvements to the safety information from ASTM F15.66 and additional members of the ASTM F15 committee on consumer products.<sup>55</sup> Recently, ASTM F15 balloted changes to ASTM F2933-19, which were developed by ASTM F15.66.<sup>56</sup> The recommendations by ASTM F15.66, as well as those provided in comments by ASTM F15 members on the ballot, include improvements to the warning content and format, and clarifications for

<sup>55</sup> Since May 2018, staff has been participating in ASTM F15.66 to address the identified hazards. Subcommittee members include manufacturers, safety and health advocacy groups, and other interested parties.

<sup>56</sup> ASTM F15 balloted revisions to ASTM F2933-19, particularly section 7, on April 6, 2020, resulting in 97 affirmatives, 7 negatives, and 293 abstentions (ASTM ballot F15 (20-02), item #15, *Proposed Changes to ASTM F2933-19 Standard Consumer Safety Specification for Crib Mattresses (WK 72077)*). Currently, ASTM F15.66 has not resolved the negative comments, so ESHF staff has considered the negative comments in developing staff's recommended changes to the safety information in ASTM F2933-19.

manufacturers, regulators, and test labs regarding the requirements of the standard. Many of the changes incorporate efforts to align with recommendations from the Ad Hoc Language task group.<sup>57</sup>

In 2016, ASTM juvenile products standards began adopting "Ad Hoc" labeling recommendations, to increase the consistency of on-product warning design among juvenile products, and to address numerous warning format issues related to capturing consumer attention, improving readability, and increasing hazard perception and avoidance behavior. The warning format recommendations from Ad Hoc are based primarily on the requirements of ANSI Z535.4, while also accounting for the wide range and unique nature of durable nursery products, the concerns raised by industry representatives, and CPSC staff's recommendations

<sup>57</sup> The "Recommended Language Approved by Ad Hoc Task Group Revision E," dated May 28, 2019, documents recommendations from the ASTM Ad Hoc Language task group for ASTM juvenile products standards.

associated with durable nursery product rulemaking projects over the past several years. These recommendations include requirements for the following:

- Content that is "easy to read and understand," not contradicted elsewhere on the product, and in English, at a minimum;
- conformance to the following sections of ANSI Z535.4-2011:
  - ANSI Z535.4, sections 6.1-6.4, which include requirements related to safety alert symbol use, signal word selection, and warning panel format, arrangement, and shape;
  - ANSI Z535.4, sections 7.2-7.6.3, which include color requirements for each panel; and
  - ANSI Z535.4, section 8.1, which addresses letter style;
- minimum text size and text alignment; and
- the use of bullets, lists, outline, and paragraph form for hazard-avoidance statements.

The Ad Hoc recommendations also include text for general labeling issues, such as labeling permanency, and content related to manufacturer contact

information and date of manufacture. The majority of the Commission's proposed modifications incorporate recommendations from stakeholders participating in ASTM F15, but several proposed modifications in the NPR deviate from what has been balloted and recommended by ASTM F15. These modifications in the NPR are based on staff's further consideration of the available data, and have not yet been reviewed by ASTM.

## VII. Proposed Standard for Crib Mattresses

The Commission proposes in the NPR a mandatory standard for crib mattresses that incorporates by reference ASTM F2933-19 with modifications to make

the standard more stringent, to further reduce the risk of injury associated with crib mattresses. Below we summarize the proposed modifications in the NPR.

### A. Cyclic Test for Coil or Spring Lacerations

To further reduce the risk of infant lacerations from exposed coils and springs, the Commission proposes in the NPR to require a cyclic loading test for all crib mattresses that use coils and springs, as follows:

1. Mattress shall be tested in an enclosed frame measuring 29 inches x 53 inches (737 mm by 1346 mm) for the purpose of restricting mattress movement. A crib meeting the requirements of ASTM F1169-19 would suffice.

2. The mattress can be placed on top of a  $\frac{3}{4}$ " piece of plywood or OSB, which is rigidly supported along the perimeter.

3. An impactor with the dimensions of the vertical impactor of ASTM F1169-19 weighing 30 lbs. shall be dropped from a height of 6 inches from the top of the mattress surface to the bottom of the impactor, 250 times in four locations (specified in Figure 1), for a total of 1,000 cycles. Cyclic loading rate shall be one drop every  $4 \pm 1$  seconds.

4. At the conclusion of the cyclic loading test, the mattress shall be removed from the test enclosure and visually inspected for exposed wires or coil springs.

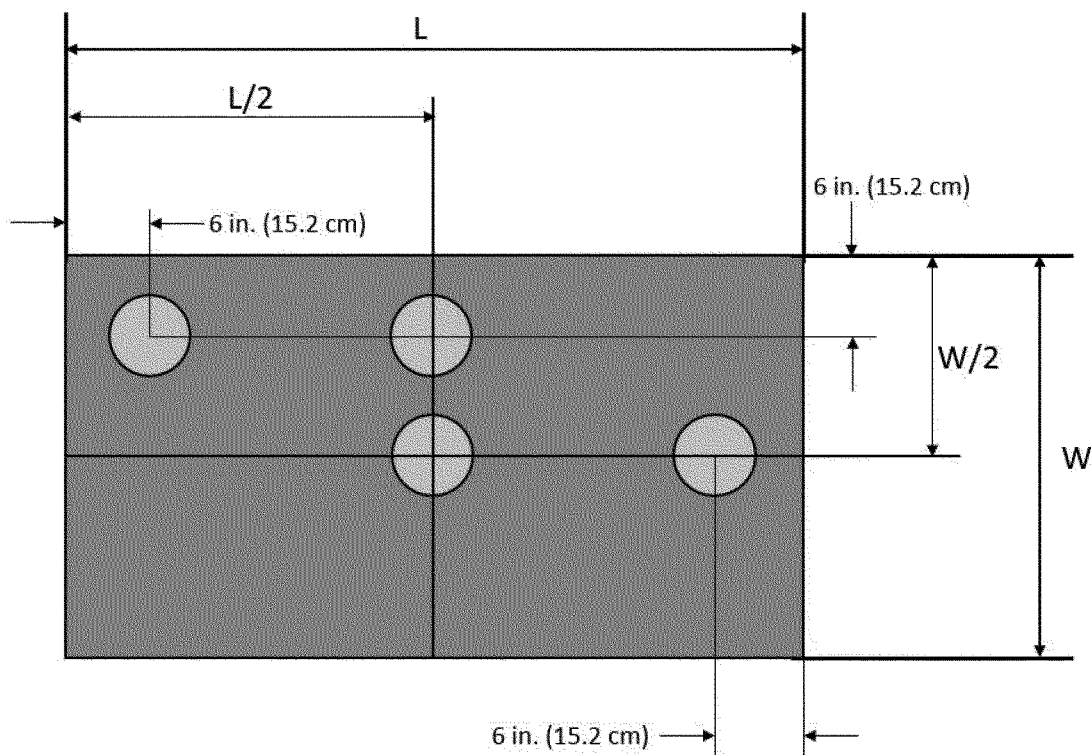

Figure 1. Impact test locations.

### B. Test for Mattress Compression From Fitted Sheets

To further reduce the risk of injury associated with corner gap entrapment from compression by fitted sheets, the Commission proposes in the NPR the following new test for full-size crib mattresses:

1. To condition the sheet for compression testing, a store-bought fitted mattress sheet intended for the tested mattress size, consisting of 100 percent cotton, shall be washed in hot water (50 °C [122 °F] or higher) and dried a minimum of two times on the

highest setting, using household textile laundering units.

2. The shrunken fitted sheet shall be placed fully on the mattress, such that each sheet edge is wrapped fully around and under the mattress.

3. The mattress, with the shrunken sheet, shall meet the *Mattress Dimension* requirements in ASTM F2933-19.

3.1. A full-size crib mattress shall be measured according to section 6.2 of the standard.

3.1.1. After dimensional measurements are taken, while no force

is being applied, measure the corner gap between the adjoining Walls C and D and the crib mattress. See Figure 1 for illustration. The gap shall not exceed 1.75 in.

3.1.1.1. Corner gap measurements shall be repeated after rotating the mattress 180° and repositioning it in the corner following sections 6.2.2.1 and 6.2.2.2 of ASTM F2933-19.

The Commission is not aware of incidents related to non-full-size crib mattresses compressing when sheets are installed. Therefore, at this time, the Commission is not proposing a similar



sheet compression test for non-full-size crib mattresses. However, the Commission seeks more information on whether to require the sheet compression test for non-full-size crib mattresses, and whether such a test would help reduce corner gap entrapments in non-full-size cribs. Accordingly, the Commission invites comments regarding the applicability of the sheet compression test for non-full-size crib mattresses and the use of sheets with non-full-size mattresses.

#### *C. Dimension Requirements for After-Market Non-Full-Size Crib Mattresses*

To further reduce the risk of injury associated with after-market non-full-size crib mattresses, the Commission proposes in the NPR to require a dimensional performance requirement for all non-full-size crib mattresses. The Commission proposes that the current performance requirements for OEM non-full-size crib mattresses in section 5.7.2 of ASTM F2933–19 be modified to apply to all non-full-size crib mattresses, regardless of whether the mattress is sold with a crib, and regardless of the shape of the mattress. The size and thickness requirements for OEM non-full-size crib mattresses in section 5.7.2 of ASTM F2933–19 repeat the requirements for non-full-size crib mattresses in section 5.17 of ASTM F406. To preclude the size requirements in each standard from unintentionally diverging in the future, the Commission proposes in the NPR to revise section 5.7.2 to refer to the requirements for non-full-size crib mattresses in F406, rather than repeating the same requirements in F2933.

#### *D. Corrections to Section 5.9 of ASTM F2933–19*

To accommodate the modification for non-full-size cribs in section 5.7, the Commission proposes in the NPR to remove references to after-market non-full-size crib mattresses from section 5.9 of ASTM F2933–19, such that section 5.9 focuses solely upon performance requirements for after-market play yard mattresses.

The Commission also notes an inconsistency in the language of ASTM F2933–19 section 5.9.1.3, which requires that a “replacement mattress” for a play yard bassinet with a bassinet attachment meet certain specifications in ASTM F2194, when tested with each brand and model it is intended to replace. This requirement for bassinet mattresses appears in the section for “after-market” mattresses. Section 3.1.1 of ASTM F2933–19 specifically exempts “replacement” mattresses from the term “after-market,” because “replacement”

mattresses are supplied by an OEM and are equivalent to the original mattress. The Commission proposes in the NPR to clarify that the requirements in section 5.9.1.3 apply to after-market mattresses, by replacing the term “replacement,” with the word “after-market.”

Appendix B to Tab B of Staff’s NPR Briefing Package contains a redline of the proposed changes to sections 5.7.2 and 5.9 of ASTM F2933–19. The Commission invites comments on this proposal. Staff intends to continue to work with ASTM to address concerns with exempting after-market, rectangular-shaped, non-full-size crib mattresses from performance requirements.

#### *E. Mattress Firmness Test*

To further reduce the risk of infant suffocation associated with surface softness in crib mattresses, the Commission proposes the following mattress firmness test for all crib mattresses within the scope of the standard, based on a test for mattress firmness in section 8 of AS/NZS 8811.1:2013:

1. Mark three equidistant points along the longitudinal center line, with one at the center and the other two equidistantly between the center and the edge of the mattress. Choose one more “worst-case” scenario test location(s) where an infant’s head might lie in a particularly soft spot, or an infant’s nose or mouth might contact a protrusion above the sleep surface.

2. Hold the test fixture with its base horizontally, and rotate it so the feeler arm is aligned with the center line of the sleep surface, and pointing in the same direction for each test; then gently set down the fixture on one of the test locations, ensuring that the edge of the bottom disk does not extend beyond the edge of the sleep surface.

3. If the level indicates that the feeler arm is approximately level when the fixture is resting on the sleep surface, observe whether the feeler arm makes any contact with the top of the sleep surface or cover. If the feeler arm is not level, decompress the mattress, allow it to settle, and start again. If the feeler arm contacts the sleep surface even when the test fixture is tilted back so as to raise the feeler arm, assume that such contact would occur had the fixture come to rest horizontally.

4. Repeat steps at remaining locations.

#### *F. Proposed Modifications to Safety Information*

As detailed in Tab C of Staff’s NPR Briefing Package, and the Appendix to Tab C, the Commission proposes in the NPR to include a significant number of

modifications to the requirements for the safety information that accompanies crib mattresses, including warning labels, packaging, and instructions. Labeling modifications include the following:

- Improved definition of “conspicuous” to clarify that the warning label’s placement must make it visible to someone who positions the mattress for use;
- Updated the general marking and labeling requirements;
- Improved warning labels and examples;
- Re-organized and clarified the marking and labeling requirements for manufacturers, test labs, and other viewers of the standard;
- Added warning requirements for full-size crib mattress packaging and improved the warning requirements for packaging of after-market mattresses for play yards and non-full-size cribs; and
- Added a new section on instructional literature, which provides an additional medium by which to communicate safe-use information.

These modifications are intended to further reduce the risk of death and serious injury associated with crib mattresses, such as SUID related to prone positioning of infants, soft bedding in sleep areas, and hazardous gaps between crib mattresses and product sides. The majority of the modifications incorporate recommendations from stakeholders participating in ASTM F15, with several deviations based on CPSC staff’s further consideration of the available data, which have not yet been reviewed by ASTM. While safety information is unlikely to effectively address the identified hazards, these modifications are likely to support the effectiveness of the proposed performance requirements, increase the likelihood of consumers understanding the hazards, and clarify the requirements for manufacturers, test labs, and other viewers of the standard.

#### **VIII. Proposed Amendment to 16 CFR Part 1112 To Include NOR for Crib Mattresses**

The CPSA establishes certain requirements for product certification and testing. Products subject to a consumer product safety rule under the CPSA, or to a similar rule, ban, standard or regulation under any other act enforced by the Commission, must be certified as complying with all applicable CPSC-enforced requirements. 15 U.S.C. 2063(a). Certification of children’s products subject to a children’s product safety rule must be based on testing conducted by a CPSC-accepted third party conformity

assessment body. *Id.* 2063(a)(2). The Commission must publish an NOR for the accreditation of third party conformity assessment bodies to assess conformity with a children's product safety rule to which a children's product is subject. *Id.* 2063(a)(3). Thus, the proposed rule for 16 CFR part 1241, *Standard Consumer Safety Specification for Crib Mattresses*, if issued as a final rule, would be a children's product safety rule that requires the issuance of an NOR.

The Commission published a final rule, *Requirements Pertaining to Third Party Conformity Assessment Bodies*, 78 FR 15836 (March 12, 2013), codified at 16 CFR part 1112 ("part 1112") and effective on June 10, 2013, which establishes requirements for accreditation of third party conformity assessment bodies to test for conformity with a children's product safety rule in accordance with section 14(a)(2) of the CPSA. Part 1112 also codifies all of the NORs issued previously by the Commission.

All new NORs for new children's product safety rules, such as the crib mattress standard, require an amendment to part 1112. To meet the requirement that the Commission issue an NOR for the crib mattress standard, as part of this NPR, the Commission proposes to amend the existing rule that codifies the list of all NORs issued by the Commission to add crib mattresses to the list of children's product safety rules for which the CPSC has issued an NOR.

Test laboratories applying for acceptance as a CPSC-accepted third party conformity assessment body to test to the new standard for crib mattresses would be required to meet the third party conformity assessment body accreditation requirements in part 1112. When a laboratory meets the requirements as a CPSC-accepted third party conformity assessment body, the laboratory can apply to the CPSC to have 16 CFR part 1241, *Standard Consumer Safety Specification for Crib Mattresses*, included in the laboratory's scope of accreditation of CPSC safety rules listed for the laboratory on the CPSC website at: [www.cpsc.gov/labsearch](http://www.cpsc.gov/labsearch).

#### IX. Proposed Amendment to Definitions in Consumer Registration Rule

The statutory definition of "durable infant or toddler product" in section 104(f) applies to all of section 104 of the CPSIA. In addition to requiring the Commission to issue safety standards for durable infant or toddler products, section 104 of the CPSIA also directed the Commission to issue a rule requiring

that manufacturers of durable infant or toddler products establish a program for consumer registration of those products. Public Law 110-314, section 104(d).

Section 104(f) of the CPSIA defines the term "durable infant or toddler product" and lists examples of such products:

(f) DEFINITION OF DURABLE INFANT OR TODDLER PRODUCT. As used in this section, the term "durable infant or toddler product"—

(1) means a durable product intended for use, or that may be reasonably expected to be used, by children under the age of 5 years; and

- (2) includes—
- (A) full-size cribs and non-full-size cribs;
  - (B) toddler beds;
  - (C) high chairs; booster chairs, and hook-on-chairs;
  - (D) bath seats;
  - (E) gates and other enclosures for confining a child;
  - (F) play yards;
  - (G) stationary activity centers;
  - (H) infant carriers;
  - (I) strollers;
  - (J) walkers;
  - (K) swings; and
  - (L) bassinets and cradles.

Public Law 110-314, section 104(f).

The product categories listed in section 104(f)(2) of the CPSIA represent a non-exhaustive list of durable infant or toddler product categories, including infant sleep products such as cribs (full-size and non-full-size), toddler beds, bassinets and cradles, and play yards. *Id.* 2056a(f)(2). Although crib mattresses are used with infant sleep products, crib mattresses are not included in the statutory list of durable infant or toddler products.

In 2009, the Commission issued a rule implementing the consumer registration requirement. 16 CFR part 1130. As the CPSIA directs, the consumer registration rule requires each manufacturer of a durable infant or toddler product to: Provide a postage-paid consumer registration form with each product; keep records of consumers who register their products with the manufacturer; and permanently place the manufacturer's name and certain other identifying information on the product. When the Commission issued the consumer registration rule, the Commission identified six additional products as "durable infant or toddler products":

- Children's folding chairs;
- changing tables;
- infant bouncers;
- infant bathtubs;
- bed rails; and
- infant slings.

16 CFR 1130.2. The Commission stated that the specified statutory categories

were not exclusive, but that the Commission should explicitly identify the product categories that are covered. The preamble to the 2009 final consumer registration rule states: "Because the statute has a broad definition of a durable infant or toddler product but also includes 12 specific product categories, additional items can and should be included in the definition, but should also be specifically listed in the rule." 74 FR 68668, 68669 (Dec. 29, 2009).

This Commission proposes in the NPR to amend part 1130 to include "crib mattresses," as defined in ASTM F2933, including full-size crib mattresses, non-full-size crib mattresses, and after-market mattresses for play yards and non-full-size cribs, as durable infant or toddler products. The Commission proposes to include "crib mattresses" as a "durable infant or toddler product" because: (1) They are intended for use, and may be reasonably expected to be used, by children under the age of 5 years; (2) they are products similar to the products listed in section 104(f)(2) of the CPSIA; (3) they are used in conjunction with other durable infant or toddler products used for unattended infant sleep, such as cribs, bassinets, and play yards; and (4) CPSC cannot fully address the risk of injury associated with such infant sleep products without addressing the hazards associated with the use of crib mattresses in these infant sleep products.

#### X. Incorporation by Reference

The Commission proposes to incorporate by reference ASTM F2933-19, with modifications to further reduce the risk of injury associated with crib mattresses. The Office of the Federal Register (OFR) has regulations concerning incorporation by reference. 1 CFR part 51. For a proposed rule, agencies must discuss in the preamble of the NPR ways that the materials the agency proposes to incorporate by reference are reasonably available to interested persons or how the agency worked to make the materials reasonably available. In addition, the preamble of the proposed rule must summarize the material. 1 CFR 51.5(a).

In accordance with the OFR's requirements, section V of this preamble summarizes the provisions of ASTM F2933-19 that the Commission proposes to incorporate by reference. ASTM F2933-19 is copyrighted. By permission of ASTM, the standard can be viewed as a read-only document during the comment period on this NPR, at: <http://www.astm.org/cpsc.htm>. To download or print the standard, interested persons

may purchase a copy of ASTM F2933–19 from ASTM, through its website (<http://www.astm.org>), or by mail from ASTM International, 100 Bar Harbor Drive, P.O. Box 0700, West Conshohocken, PA 19428. Alternatively, interested parties may inspect a copy of the standard at CPSC's Division of the Secretariat by contacting Alberta E. Mills, Division of the Secretariat, U.S. Consumer Product Safety Commission, 4330 East-West Highway, Bethesda, MD 20814; telephone: 301–504–7479; email: [cpsc-os@cpsc.gov](mailto:cpsc-os@cpsc.gov).

## XI. Effective Date

The Administrative Procedure Act (APA) generally requires that the effective date of a rule be at least 30 days after publication of the final rule. 5 U.S.C. 553(d). The Commission proposes a 6-month effective date for a final rule on crib mattresses. Barring evidence to the contrary, 6 months is typically sufficient time for suppliers to come into compliance with a new standard, and this amount of time is typical for other CPSIA section 104 rules. Six months is also the period that the Juvenile Products Manufacturers Association typically allows for products in their certification program to shift to a new standard once that new standard is published. Therefore, juvenile product manufacturers are accustomed to adjusting to new standards within this time. The Commission notes that this NPR for crib mattresses contains additional testing requirements and labeling changes, and that the current global COVID–19 pandemic has affected supply chains. The Commission invites comments, particularly from small businesses, regarding the amount of time they will need to come into compliance with a final rule.

## XII. Regulatory Flexibility Act<sup>58</sup>

### A. Introduction

The Regulatory Flexibility Act (RFA) requires that agencies review a proposed rule for the rule's potential economic impact on small entities, including small businesses. Section 603 of the RFA generally requires that agencies prepare an initial regulatory flexibility analysis (IRFA) and make the analysis available to the public for comment when the agency publishes an NPR. 5 U.S.C. 603. Section 605 of the RFA provides that an IRFA is not required if the agency certifies that the rule will not, if promulgated, have a significant economic impact on a substantial number of small entities. The IRFA

must describe the impact of the proposed rule on small entities and identify significant alternatives that accomplish the statutory objectives and minimize any significant economic impact of the proposed rule on small entities. Specifically, the IRFA must contain:

- A description of the reasons why action by the agency is being considered;
- a succinct statement of the objectives of, and legal basis for, the proposed rule;
- a description of, and where feasible, an estimate of the number of small entities to which the proposed rule will apply;
- a description of the projected reporting, recordkeeping, and other compliance requirements of the proposed rule, including an estimate of the classes of small entities subject to the requirements and the type of professional skills necessary for the preparation of reports or records; and
- identification, to the extent possible, of all relevant federal rules that may duplicate, overlap, or conflict with the proposed rule.

Additionally, the IRFA must describe any significant alternatives to the proposed rule that accomplish the stated objectives of applicable statutes and minimize any significant economic impact of the proposed rule on small entities. CPSC staff prepared an IRFA for this rulemaking which appears at Tab F of the Staff's NPR Briefing Package. We provide a summary of the IRFA below.

### B. Agency Action, NPR Objectives, Product Description, and Market Description

An explanation of why the agency is considering issuing a mandatory rule for crib mattresses and a statement of the objectives of, and legal basis for, the proposed rule, are set forth in section I of this preamble. Section II of this preamble describes the types of crib mattresses within the scope of the NPR, the market for crib mattresses, and the use of crib mattresses in the United States.

### C. Small Entities to Which the NPR Would Apply

Manufacturers of crib mattresses are typically categorized under the NAICS category 337910 (Mattress Manufacturing). The Small Business Administration (SBA) guidelines consider mattress manufacturing establishments to be small if they have

fewer than 1,000 employees.<sup>59</sup> Importers of crib mattresses are typically categorized under NAICS code 423210 (Furniture Merchant Wholesalers) and SBA guidelines would consider them small if they have fewer than 100 employees.

Staff identified 26 manufacturers and importers of full-size and non-full-size crib mattresses, and after-market play yard mattresses. A majority of the 26 firms have under 50 employees. Most of the firms are domestic manufacturers (14) or domestic importers (8). Four firms are foreign. Sixteen of these 26 firms meet the SBA criteria for small businesses, and 10 firms would be considered large according to the SBA criteria.<sup>60</sup> Among the 16 small domestic firms identified by staff, 9 were manufacturers and 7 were importers. Staff observes that annual revenue varies among small domestic firms, as median annual revenue is estimated at \$6,740,000, but average annual revenue is higher at \$46,037,100.

Online registries are widely available for new crib mattresses. Producers supply crib mattresses to the U.S. market via electronic commerce websites, such as *Amazon.com*, *Buy Buy Baby*, *Hayneedle*, *KOHL'S*, *Overstock*, *Walmart*, and *Wayfair*. According to a 2017 Statista survey of baby products, the majority (59 percent) of respondents indicated they buy baby products mainly or exclusively online.<sup>61</sup> Staff expects that consumers of crib mattresses that do not buy online, purchase their mattresses in retail stores.

The majority of crib mattresses on the market are full-size crib mattresses. Staff estimates that 40 percent of crib mattresses on the market are coil/innerspring mattresses, and approximately 60 percent of crib mattresses are foam-core mattresses.<sup>62</sup> Among small domestic manufacturers, approximately 45 percent of available crib mattresses are coil mattresses. Among small importers, just 25 percent of available crib mattresses are composed of a coil core. Seventy-five percent of crib mattresses supplied by small domestic importers of crib mattresses consist of a foam core. Staff identified at least three small firms that only produce foam-core mattresses,

<sup>59</sup> The size guidelines are established by the U.S. Small Business Administration (SBA).

<sup>60</sup> Based on size and revenue data from Reference USA and firm financial reports, websites, and press releases.

<sup>61</sup> Statista Survey of Baby Products in the U.S., 2017.

<sup>62</sup> Based on staff's compiled search results of data available on the internet found March through May 2020.

<sup>58</sup> See Tab F of Staff's NPR Briefing Package for additional information on the RFA.

while the majority of small entities produce a combination of both coil and foam-core crib mattresses.

#### D. Impact of the Proposed Rule on Small Manufacturers and Importers

Of the 16 small manufacturers and importers identified by staff, 12 (8 manufacturers and 4 importers) are members of the JPMA, but staff cannot determine how many crib mattresses are currently certified to ASTM F2933–19. Many of the firms that would be subject to the draft proposed rule are known to produce a variety of children’s products that are already subject to CPSC children’s product safety rules, and therefore, are familiar with such requirements.<sup>63</sup> Additionally, two firms that are not JPMA members supply products that claim to meet ASTM standards. The Commission seeks comments from small firms on the number of mattress models they would typically certify to the ASTM standard annually.

Manufacturers and importers of crib mattresses would be responsible for ensuring that their products comply with the requirements of the proposed rule. If a crib mattress does not comply with the requirements, the manufacturers or importers will need to modify the product or cease manufacture or importation. Importers might be able to work with their manufacturers to supply compliant mattresses and could potentially switch suppliers if their current supplier is unwilling to supply current mattresses. Alternatively, importers might simply drop the noncompliant mattresses from their product lines.

Additionally, as required by section 14 of the CPSA and its implementing regulations, manufacturers and importers of crib mattresses would be required to certify that their crib mattresses comply with the requirements of a final rule, if issued, based on the results of third party testing by a CPSC-accepted third party conformity assessment body (*i.e.*, testing laboratory). Crib mattresses are already subject to third party testing requirements and adoption of the proposed rule would only augment existing testing requirements.<sup>64 65</sup>

<sup>63</sup> Crib mattresses listed for sale on a variety of online retail websites often include product descriptions indicating that the crib mattress product meets CPSC general safety standards, while not referencing any one specific CPSC safety standard.

<sup>64</sup> Manufacturers and importers of children’s products must certify compliance with applicable federal safety requirements in a Children’s Product Certificate (CPC). In most instances, testing by a third party CPSC-accepted laboratory must serve as the basis for the production of the CPC.

#### 1. Costs Associated With Modifying Products

The majority of crib mattresses currently available on the market will not require extensive modification to comply with the proposed rule. Staff reports that the majority of crib mattresses they tested already meet the performance requirements of the proposed rule. We do not know the exact costs of modifying crib mattresses to comply with the proposed rule, which would vary by product model. Modifying crib mattresses to comply with the compression standard could be as simple as adding a perimeter border wire to the mattress edge or an anti-sag weight distribution bar to the mattress structure. However, staff believes it possible that a required modification could be prohibitively expensive, and therefore, the proposed rule may result in the removal of certain crib mattresses from commerce.

Generally, the costs associated with providing instructional materials are low on a per-unit basis. Many firms already provide instructions with their products, but they may have to change the content or formatting of the instructions to comply. Likewise, the cost of warning labels is generally low, especially if some warning labels are already present, and the product does not need to be modified to accommodate new labels.

#### 2. Third Party Testing Costs

If issued, a final rule would require all manufacturers and importers of crib mattresses to meet additional third-party testing requirements under section 14 of the CPSA. Third-party testing requirements will include any physical and mechanical test requirements specified in the final crib mattress rule. Based on information from a testing laboratory, the cost of testing to the current version of ASTM F2933 is \$200 to \$250 per sample. The additional testing that would be required by the proposed rule would increase this cost by \$50 to \$75 per sample tested. Thus, the total cost of the third-party testing would be \$250 to \$325 per sample. Given that the average number of crib mattress models per firm is approximately 12, the cost of the third-party testing could be about \$3,000 to \$3,900, if only one model per sample were required to provide a high degree

<sup>65</sup> Mattresses intended for children must be tested at a third party test laboratory or a fire-walled internal laboratory: [https://cpsc.gov/s3fs-public/pdfs/blk\\_media\\_mattress.pdf](https://cpsc.gov/s3fs-public/pdfs/blk_media_mattress.pdf). In either case, the lab would need to be CPSC-accepted to test to the standards since crib mattresses are considered to be primarily intended for children 12 and under.

of assurance that the model complied with the requirements of the rule.

Additionally, according to conformity assessment bodies that staff contacted, for each mattress model to be tested, the firm will need to provide the crib or play yard equipment intended to be used with the mattress being tested. However, to comply with ASTM F2933–19 and other CPSC requirements for children’s products, the costs of supplying a crib, crib mattress, or play yard to the conformity assessment body are already borne by the producer for testing under previously adopted rules and standards. Regardless, third-party testing facilities have indicated that they are unable to store equipment that will be needed or used during testing, such as cribs or play yards, for long periods of time. Therefore, ensuring that all crib equipment needed for testing arrives at the testing lab at the appropriate time may pose a logistical burden, even if there is no increase in monetary costs for freight or shipping.

Additional costs of the proposed testing would include the cost of the 100 percent cotton sheets used during testing.<sup>66 67</sup> These sheets would be used in the proposed “Compression Test” for full-size crib mattresses. While the number of times a sheet can be reused has not yet been determined, we assume one new sheet per test. The cost of one, 100 percent cotton, full-size crib mattress sheet is approximately \$10.<sup>68</sup> Staff estimates approximately 3 out of 4 crib mattresses on the market are full-size crib mattresses.<sup>69</sup> Therefore, for a typical manufacturer or importer with 12 crib mattress models, 9 might be full-size crib mattresses, and the additional cost of one fitted sheet per full-size mattress would be \$90, plus the testing costs charged by the conformity assessment body.

For a subset of mattresses, *i.e.*, metal coil spring crib mattresses, the proposed rule would include cyclic impact testing called the “Cyclic Load Test.” During the Cyclic Load Test, an impactor weighing 30 pounds shall be dropped repetitively from above the mattress surface, and across four different locations on the mattress. As a result of the Cyclic Load Test, the mattress product is rendered unusable for either of the proposed mattress firmness or

<sup>66</sup> The proposed test includes measuring the mattress without a fitted sheet and with a twice-washed fitted sheet.

<sup>67</sup> With input from the ASTM standards organization, CPSC staff will determine the number of times a sheet can be reused.

<sup>68</sup> Based on compiled search results of data available on the internet.

<sup>69</sup> Based on a review of over 300 mattress models available for sale on the internet.

compression tests. Under cyclic load testing, the mattress product could be misshapen, deformed, or otherwise destroyed, and wire coils may protrude from the mattress surface.

Approximately 40 percent of crib mattresses available for sale are metal spring coil mattresses. The average cost of a crib mattress available for sale in the United States is \$150,<sup>70</sup> and on average, the typical manufacturer or importer of crib mattresses tests 12 models annually. Therefore, the cost to the typical small firm of the destroyed mattresses would amount to 40 percent of \$1,800 (12 models × \$150), or approximately \$720, as a result of the proposed Cyclic Load Test.

Based on the foregoing, for a typical manufacturer or importer with 12 crib mattress models that requires only one test per model to provide a high degree of assurance, the full cost of third party testing will be approximately \$3,000 to \$3,900, plus \$90 in costs for fitted-sheet testing materials, and \$720 for the cost of used test mattresses, for a total of \$3,810 to \$4,710 or an average of \$318 to \$393 per model.

### 3. Summary of Impacts

Generally, based on Small Business Administration guidelines, CPSC considers impacts that exceed one percent of a firm's revenue to be *potentially* significant. The lowest reported annual revenue for any small domestic firm producing fewer than four crib mattress models was \$1.36 million. One percent of annual revenue for the firm is \$13,600 ( $\$1,360,000 \times 0.01$ ). Consequently, if the costs of modifying their mattresses to comply with the standard exceeded \$13,600, the rule could have a significant impact on some small firms. This would include the costs of modifying noncompliant mattresses to comply with the requirements, the loss of revenue that results from removing noncompliant mattresses from their product line, and the cost of third-party testing. For manufacturers or importers with greater revenue, the impact of the proposed rule would have to be higher than this for the impact to be considered significant.

Given that a substantial number of mattresses already comply with the requirements of the proposed rule, and some of the testing costs are already being borne by firms that certify to the current voluntary standard, the Commission considers it unlikely that the rule would have a significant impact on a substantial number of small

entities. However, we request comments on the costs of the proposed rule, or impediments to modifying existing crib mattress products to conform to the proposed rule, especially those that would result in the removal of the mattress product from the market and other impacts of the draft proposed rule on small manufacturers and importers.

#### *E. Other Federal Rules That May Duplicate, Overlap, or Conflict With the Draft Proposed Rule*

CPSC staff did not identify any other federal rules that duplicate, overlap, or conflict with the proposed rule.

#### *F. Alternatives Considered To Reduce the Impact on Small Entities*

The Commission considered the following alternatives to the proposed rule to reduce the impact on small businesses. The Commission requests comments on these alternatives or other alternatives that could reduce the potential burden on small entities.

##### 1. Adopt ASTM F2933–19 Without Modification

The Commission considered proposing to incorporate by reference ASTM F2933–19, without any modifications, and to direct staff to work with ASTM to improve test methods and the firmness of crib mattresses in a future revision of the voluntary standard. This alternative could reduce the impact of the rule on small businesses, but, according to CPSC staff, the reduction would not be expected to be very significant. As discussed in the IRFA analysis in Tab F of Staff's NPR Briefing Package, and in this preamble, many crib mattresses probably already comply with the proposed standard. The additional testing costs associated with the modifications to ASTM F2933–19 in the proposed rule would only increase the testing costs by \$50 to \$75 per sample. Moreover, adopting ASTM F2933–19 without modification would not address all of the identified hazard patterns associated with crib mattresses.

##### 2. Small Batch Exemption

Under Section 14(d)(4)(C)(ii) of the CPSA, the Commission cannot "provide any alternative requirements or exemption" from third party testing for "durable infant or toddler products," as defined in section 104(f) of the Consumer Product Safety Improvement Act of 2008. Consequently, the Commission cannot create a small batch exemption absent a statutory change.

##### 3. Delay the Effective Date of the Requirements

Typically, the Commission proposes an effective date of 6 months for durable nursery product rules. Six months is generally considered sufficient time for suppliers to come into compliance with a proposed durable infant or toddler product rule, unless specific circumstances evince the need for a longer effective date. Additionally, 6 months from the change in a voluntary standard is the time frame that JPMA uses for its certification program, so compliant manufacturers are used to a 6-month time frame to comply with a modified standard. The Commission proposes a 6-month effective date for a final rule on crib mattresses.

One alternative the Commission will consider to reduce the impact of a mandatory rule on small firms is to set an effective date later than 6 months. Implementing a later effective date could mitigate the effects of the rule on small businesses. For businesses that would choose to exit the crib mattress market, or discontinue certain crib mattress models currently in production (rather than produce conforming products), such a delay might provide them with more time to adjust marketing towards other product offerings, sell inventory, or consider alternative business opportunities. The Commission requests comments on the proposed 6-month effective date.

##### 4. Not Issue a Mandatory Standard

Another option available to the Commission that would reduce the burden on small firms is not to adopt a mandatory standard for crib mattresses. Although this option would eliminate the cost impacts of complying with the proposed rule, failure to issue a mandatory standard for crib mattresses would not adequately address the hazard patterns for crib mattresses, especially for hazard patterns that are not adequately addressed in the voluntary standard.

#### *G. IRFA Conclusion*

CPSC staff evaluated the possible impacts of the proposed rule on small entities, as required by the RFA. Staff identified 26 manufacturers and importers of mattress products, 16 of which would be considered small businesses (9 manufacturers and 7 importers). The potential impacts include the costs of modifying mattresses to conform to the requirements, the lost revenue if some models are discontinued, and the costs associated with the third-party testing. The Commission believes it possible

<sup>70</sup>Price estimated from data available on the internet, collected between January 2020 and June 2020.

that the proposed rule could have a significant impact on some small firms, but cannot estimate how many. However, the Commission believes it unlikely that the proposed rule would have a significant impact on a substantial number of small entities. The Commission considered several staff-identified alternatives to the proposed rule, to reduce any adverse impact on small firms. The Commission concludes that each of these alternatives would provide limited relief, or is not available due to statutory limitations. The Commission invites comments, particularly from small businesses, on the cost of making necessary modifications to noncomplying crib mattress models to comply with the proposed rule, and alternatives that could reduce the burden on small businesses.

**XIII. Environmental Considerations**

The Commission’s regulations address whether the agency is required to prepare an environmental assessment or an environmental impact statement. Under these regulations, certain categories of CPSC actions normally

have “little or no potential for affecting the human environment,” and therefore do not require an environmental assessment or an environmental impact statement. Safety standards providing requirements for products come under this categorical exclusion. 16 CFR 1021.5(c)(1). The NPR for crib mattresses falls within the categorical exclusion.

**XIV. Paperwork Reduction Act**

This proposed rule for crib mattresses contains information collection requirements that are subject to public comment and review by the Office of Management and Budget (“OMB”) under the Paperwork Reduction Act of 1995 (44 U.S.C. 3501–3521). In this document, pursuant to 44 U.S.C. 3507(a)(1)(D), we set forth:

- A title for the collection of information;
- a summary of the collection of information;
- a brief description of the need for the information and the proposed use of the information;
- a description of the likely respondents and proposed frequency of

response to the collection of information;

- an estimate of the burden that shall result from the collection of information; and
- notice that comments may be submitted to the OMB.

*Title:* Safety Standard for Crib Mattresses.

*Description:* The proposed rule would require each crib mattress within the scope of the rule to comply with ASTM F2933–19, *Standard Consumer Safety Specification for Crib Mattresses*, including the proposed additional requirements summarized in section VII of this preamble. Section 7 of ASTM F2933–19, and a proposed new section 8 in the NPR, contain requirements for marking, labeling, and instructional literature. These requirements fall within the definition of “collection of information,” as defined in 44 U.S.C. 3502(3).

*Description of Respondents:* Persons who manufacture or import crib mattresses.

*Estimated Burden:* We estimate the burden of this collection of information as follows:

TABLE 8—ESTIMATED ANNUAL REPORTING BURDEN

16 CFR section	Number of respondents	Frequency of responses	Total annual responses	Hours per response	Total burden hours
1241.2(a), (b) .....	26	12	312	1	312

Our estimate is based on the following:

The Commission proposes in the NPR modifications to section 7 of ASTM 2933–19, and a new section 8 on instructional literature, to bring the standard into alignment with other safety standards for durable infant or toddler products. For example, in addition to improved warning format and content, proposed modifications to section 7.1.1 of ASTM F2933–19 would require that the name and the place of business (city, state, and mailing address, including zip code) or telephone number of the manufacturer, distributor, or seller be marked clearly and legibly on each product and its retail package. Proposed modifications to section 7.1.2 of ASTM F2933–19 would also require a code mark or other means that identifies the date (month and year, as a minimum) of manufacture. Proposed modifications to section 7.2 of ASTM F2933–19 would require marking and labeling on the product to be permanent.

Twenty-six known entities supply crib mattresses to the U.S. market and

these entities may need to make some modifications to existing product labels. We estimate that the time required to make these modifications is about 1 hour per model. Based on an evaluation of supplier product lines, each entity supplies an average of 12 models of crib mattresses;<sup>71</sup> therefore, the estimated burden associated with labels is 1 hour per model × 26 entities × 12 models per entity = 312 hours. We estimate the hourly compensation for the time required to create and update labels is \$32.74 (U.S. Bureau of Labor Statistics, “Employer Costs for Employee Compensation,” March 2020, total compensation for all sales and office workers in goods-producing private industries: <http://www.bls.gov/ncs/>). Therefore, the estimated annual cost to industry associated with the labeling requirements is \$10,214.88 (\$32.74 per hour × 312 hours = \$10,214.88). No

<sup>71</sup> This number was derived during the market research phase of the initial regulatory flexibility analysis by dividing the total number of crib mattresses supplied by all crib mattress suppliers by the total number of crib mattress suppliers.

operating, maintenance, or capital costs are associated with the collection.

The NPR also proposes a new section 8 that would require instructions to be supplied with the crib mattress. The instructions would be required to: (a) Be easy to read and understand; (b) include information regarding assembly, maintenance, cleaning, and use, where applicable; and (c) address the same warning and safety-related statements that must appear on the product, with similar formatting requirements, but without the need to be in color. Under the OMB’s regulations (5 CFR 1320.3(b)(2)), the time, effort, and financial resources necessary to comply with a collection of information that would be incurred by persons in the “normal course of their activities” are excluded from a burden estimate, where an agency demonstrates that the disclosure activities required to comply are “usual and customary.” Based on staff’s review of product information online, approximately 80 percent of firms that supply cribs to the crib mattress market already provide instructional literature to consumers for

products intended for use by children. All of the firms which supply crib mattresses already provide customer support for use of their children's products. Therefore, we tentatively estimate that no burden hours are associated with the proposed section 8 of ASTM F2933–19, because any burden associated with supplying instructions with crib mattresses would be “usual and customary” and not within the definition of “burden” under the OMB's regulations.

Based on this analysis, the proposed standard for crib mattresses would impose a burden to industry of 312 hours at a cost of \$10,214.88 annually.

In compliance with the Paperwork Reduction Act of 1995 (44 U.S.C. 3507(d)), we have submitted the information collection requirements of this rule to the OMB for review. Interested persons are requested to submit comments regarding information collection by November 25, 2020, to the Office of Information and Regulatory Affairs, OMB (see the **ADDRESSES** section at the beginning of this document).

Pursuant to 44 U.S.C. 3506(c)(2)(A), we invite comments on:

- Whether the collection of information is necessary for the proper performance of the CPSC's functions, including whether the information will have practical utility;
- the accuracy of the CPSC's estimate of the burden of the proposed collection of information, including the validity of the methodology and assumptions used;
- ways to enhance the quality, utility, and clarity of the information to be collected;
- ways to reduce the burden of the collection of information on respondents, including the use of automated collection techniques, when appropriate, and other forms of information technology; and
- the estimated burden hours associated with label modification, including any alternative estimates.

#### XV. Preemption

Section 26(a) of the CPSA, 15 U.S.C. 2075(a), states that when a consumer product safety standard is in effect and applies to a product, no state or political subdivision of a state may either establish or continue in effect a standard or regulation that prescribes requirements for the performance, composition, contents, design, finish, construction, packaging, or labeling of such product dealing with the same risk of injury unless the state requirement is identical to the federal standard. Section 26(c) of the CPSA also provides that states or political subdivisions of states may apply to the Commission for an

exemption from this preemption under certain circumstances. Section 104(b) of the CPSIA refers to the rules to be issued under that section as “consumer product safety rules.” Therefore, the preemption provision of section 26(a) of the CPSA would apply to a rule issued under section 104.

#### XVI. Request for Comments

This Commission proposes a rule under section 104(b) of the CPSIA to issue a consumer product safety standard for crib mattresses, to amend part 1112 to add crib mattresses to the list of children's product safety rules for which the CPSC has issued an NOR, and to amend part 1130 to identify crib mattresses as a durable infant or toddler product subject to CPSC consumer registration requirements. The Commission requests comments on the proposal to incorporate by reference ASTM F2933–19, with modifications to address mattress firmness, mattress compression, lacerations from coils and springs, dimensional requirements for non-full-size cribs, and improve warnings and instructions. The Commission also requests comments on the proposed effective date; the costs of compliance with, and testing to, the proposed Safety Standard for Crib Mattresses; and any aspect of this proposal. During the comment period, the ASTM F2933–19 Standard Consumer Safety Specification for Crib Mattresses, is available as a read-only document at: <http://www.astm.org/cpsc.htm>.

Comments should be submitted in accordance with the instructions in the **ADDRESSES** section at the beginning of this document.

#### List of Subjects

##### 16 CFR Part 1112

Administrative practice and procedure, Audit, Consumer protection, Reporting and recordkeeping requirements, Third party conformity assessment body.

##### 16 CFR Part 1130

Administrative practice and procedure, Business and industry, Consumer protection, Reporting and recordkeeping requirements.

##### 16 CFR Part 1241

Consumer protection, Imports, Incorporation by reference, Infants and children, Labeling, Law enforcement, and Mattresses.

For the reasons discussed in the preamble, the Commission proposes to amend Title 16 of the Code of Federal Regulations as follows:

#### PART 1112—REQUIREMENTS PERTAINING TO THIRD PARTY CONFORMITY ASSESSMENT BODIES

- 1. The authority citation for part 1112 continues to read as follows:

**Authority:** 15 U.S.C. 2063; Pub. L. 110–314, section 3, 122 Stat. 3016, 3017 (2008).

- 2. Amend § 1112.15 by adding paragraph (b)(51) to read as follows:

**§ 1112.15 When can a third party conformity assessment body apply for CPSC acceptance for a particular CPSC rule and/or test method?**

\* \* \* \* \*

(b) \* \* \*

(51) 16 CFR part 1241, Safety Standard for Crib Mattresses.

\* \* \* \* \*

- 3. The authority citation for part 1130 continues to read as follows:

**Authority:** 15 U.S.C. 2056a, 2056(b).

- 4. Amend § 1130.2 by adding paragraph (a)(19) to read as follows:

#### PART 1130—REQUIREMENTS FOR CONSUMER REGISTRATION OF DURABLE INFANT OR TODDLER PRODUCTS

##### § 1130.2 Definitions.

\* \* \* \* \*

(a) \* \* \*

(19) Crib mattresses.

\* \* \* \* \*

- 5. Add part 1241 to read as follows:

#### PART 1241—SAFETY STANDARD FOR CRIB MATTRESSES

Sec.

1241.1 Scope.

1241.2 Requirements for crib mattresses.

**Authority:** Sec. 104, Pub. L. 110–314, 122 Stat. 3016 (15 U.S.C. 2056a); Sec. 3, Pub. L. 112–28, 125 Stat. 273.

##### § 1241.1 Scope.

This part establishes a consumer product safety standard for crib mattresses. The scope of this standard for crib mattresses includes all crib mattresses within the scope of ASTM F2933, *Standard Consumer Safety Specification for Crib Mattresses*, including: Full-size crib mattresses, non-full-size crib mattresses, and after-market mattresses for play yards and non-full-size cribs.

##### § 1241.2 Requirements for crib mattresses.

(a) Except as provided in paragraph (b) of this section, each crib mattress must comply with all applicable provisions of ASTM F2933–19, *Standard Consumer Safety Specification for Crib Mattresses* (approved on June 15, 2019). The Director of the Federal

Register approves this incorporation by reference in accordance with 5 U.S.C. 552(a) and 1 CFR part 51. You may obtain a copy from ASTM International, 100 Bar Harbor Drive, P.O. Box 0700, West Conshohocken, PA 19428; <http://www.astm.org/cpsc.htm>. Once incorporated by reference, you may review a read-only copy of ASTM F2933–19 at <http://www.astm.org/READINGROOM/>. You may also inspect a copy at the Division of the Secretariat, U.S. Consumer Product Safety Commission, Room 820, 4330 East-West Highway, Bethesda, MD 20814, telephone 301–504–7923, or at the National Archives and Records Administration (NARA). For information on the availability of this material at NARA, call 202–741–6030, or go to: [http://www.archives.gov/federal\\_register/code\\_of\\_federal\\_regulations/ibr\\_locations.html](http://www.archives.gov/federal_register/code_of_federal_regulations/ibr_locations.html).

(b) Comply with ASTM F2933–19 with the following additions or exclusions:

(1) Instead of complying with section 3.1.2 of ASTM F2933–19, comply with the following:

(i) 3.1.2 *Conspicuous*, adj—visible while the mattress is being placed in its intended use position.

(ii) [Reserved]

(2) Add the following paragraph to section 3.1 of ASTM F2933–19:

(i) 3.1.11 *Sleep surface*—The product component, or group of components, providing the horizontal plane, or nearly horizontal plane ( $\leq 10^\circ$ ), intended to support an infant during sleep.

(ii) [Reserved]

(3) Instead of complying with section 5.7.1.1 of ASTM F2933–19, comply with the following:

(i) 5.7.1.1 *Mattress Size*—The dimensions of a full-size crib mattress shall measure at least  $27\frac{1}{4}$  in. (690 mm) wide and  $51\frac{5}{8}$  in. (1310 mm) long. When the mattress is placed against the perimeter and in the corner of the crib, the corner gap shall not exceed 1.75 in. (44.5 mm). Dimensions shall be tested in accordance with 6.2.

(ii) [Reserved]

(4) Instead of complying with section 5.7.2.1 and 5.7.2.2 of ASTM F2933–19, comply with the following:

(i) 5.7.2.1 *Mattress supplied with a non-full-size crib*: Shall meet the specifications of *Mattresses for Rigid sided products* of Consumer Safety Specification ASTM F406 when tested with the non-full-size crib product with which it is supplied.

(ii) 5.7.2.2 *After-market mattresses for non-full-size cribs*: Shall be treated as though the mattresses were “the mattress supplied with a non-full-size

crib” and shall meet the specifications of *Mattresses for Rigid sided products* in Consumer Safety Specification ASTM F406, when tested to the equivalent interior dimension of the product for which it is intended to be used.

(5) In section 5.9 of ASTM F2933–19, remove the term “and Non-Full Size Crib.”

(6) In section 5.9.1 of ASTM F2933–19, replace the term “For Mesh/Fabric Sided Products and Rigid Sided Non-Rectangular Products” with “For Mesh/Fabric Sided Play Yard Products.”

(7) In section 5.9.1.2 of ASTM F2933–19, remove the term “Mattresses for Rigid sided products;”.

(8) In section 5.9.1.3 of ASTM F2933–19, replace the term “replacement” with “after-market.”

(9) Add the following paragraphs to section 5 of ASTM F2933–19:

(i) 5.10 *Mattress Firmness*.

(ii) 5.10.1 All crib mattresses within the scope of this standard, when tested in accordance with 6.3, the feeler arm shall not contact the sleep surface of the crib mattress.

(iii) 5.11 *Coil Springs*.

(iv) 5.11.1 When tested in accordance with 6.4, there shall be no exposed coil springs or metal wires. The requirements in this section only pertain to crib mattresses with coil springs.

(10) Renumber section 6.2.2 of ASTM F2933–19 to 6.2.3.

(11) Add the following paragraph to section 6.2.2 of ASTM F2933–19:

(i) 6.2.2 *Test Equipment-Mattress Sheet*:

(ii) [Reserved]

(12) Renumber section 6.2.2.1 of ASTM F2933–19 to 6.2.3.1.

(13) Add the following paragraph to section 6.2.2.1 of ASTM F2933–19:

(i) 6.2.2.1 The mattress sheet shall be 100% cotton and fitted for the mattress to be tested.

(ii) [Reserved]

(14) Renumber section 6.2.2.2 of ASTM F2933–19 to 6.2.3.2.

(15) Add the following paragraph to section 6.2.2.2 of ASTM F2933–19:

(i) 6.2.2.2 The mattress sheet shall be washed in hot water (50 °C [122 °F] or higher) and dried a minimum of two times on the highest setting using household textile laundering units. This shall be the test mattress sheet.

(ii) [Reserved]

(16) Renumber section 6.2.2.3 of ASTM F2933–19 to 6.2.3.3.

(17) Renumber section 6.2.2.4 of ASTM F2933–19 to 6.2.3.4.

(18) Add the following paragraphs to section 6.2.3 of ASTM F2933–19:

(i) 6.2.3.5 Measure the shortest gap between the mattress and the mattress

measuring box at the corner adjoining Walls C and D after the dimensions of the mattress have been recorded. The mattress shall not be moved before or during measurement. This shall be the corner gap measurement.

(ii) 6.2.3.6 Rotate the mattress 180° such that the opposing corner is adjacent to Walls C and D, then repeat 6.2.3.2 and 6.2.3.5.

(iii) 6.2.3.7 The test mattress sheet shall be placed on the mattress such that each sheet edge is wrapped fully around and under the mattress.

(iv) 6.2.3.8 The mattress with test mattress sheet shall be measured following steps 6.2.3.1 through 6.2.3.6. The mattress dimensions shall meet the requirements in 5.7.

(19) Add the following paragraphs as section 6.3 of ASTM F2933–19.

(i) 6.3 *Mattress Firmness*.

(ii) 6.3.1 *Test Fixture*:

(iii) 6.3.1.1 The fixture, as shown in Fig. 2, shall be a rigid, robust object with a round footprint of diameter  $203 \pm 1$  mm, and an overall mass of  $5200 \pm 20$  g. The lower edge of the fixture shall have a radius not larger than 1 mm. Overhanging the footprint by  $40 \pm 2$  mm shall be a flexible, flat bar of width  $12 \pm 0.2$  mm with square-cut ends. This bar may be fashioned from a shortened hacksaw blade. The bar shall rest parallel to the bottom surface of the fixture and shall be positioned at a height of  $15 \pm 0.2$  mm above the bottom surface of the fixture. The bar shall lay directly over a radial axis of the footprint (*i.e.*, such that a longitudinal centerline of the bar would pass over the center of the footprint).

(iv) 6.3.1.2 Included on the fixture, but not overhanging the footprint, shall be a linear level that is positioned on a plane parallel to the bar, and in a direction parallel to the bar.

(v) 6.3.1.3 Other parts of the fixture, including any handle arrangement and any clamping arrangement for the bar, shall not comprise more than 30% of the total mass of the fixture, and shall be mounted as concentric and as low as possible.

(vi) 6.3.2 *Test Method*:

(vii) 6.3.2.1 Mattresses that are supplied with a product shall be tested when positioned on that product. Mattresses sold independent of a product, shall be tested on a flat, rigid, horizontal support. After-market mattresses for play yards and non-full-size cribs shall be tested with each brand and model of product it is intended to replace.

(viii) 6.3.2.2 Where a user of a mattress could possibly position either side face up, even if this is not an



intended use, then both sides of the mattress shall be tested.

(ix) 6.3.2.3 Before testing each mattress, the following steps shall be followed:

(A) Verify there is no excess moisture in the mattress, beyond reasonable laboratory humidity levels.

(B) Allow sufficient time per the manufacturer's instructions to fully inflate, if shipped in a vacuum sealed package.

(C) Shake and or agitate the mattress in order to fully aerate and distribute all internal components evenly.

(D) Place the mattress in the manufacturer's recommended use position if there is one, in the supplied product, or on a flat, rigid, horizontal support.

(E) Let the mattress rest for at least 5 minutes.

(F) Mark a longitudinal centerline on the mattress sleep surface, and divide this line in half. This point will be the first test location. Then further divide the two lines on either side of the first test location into halves. These will be the second and third test locations.

(x) 6.3.2.4.

(A) Position the test fixture on each of the test locations, with the footprint of the fixture centered on the location, with the bar extending over the centerline and always pointing at the same end of the mattress sleep surface.

(B) At each test location in turn, rotate the bar to point in the required direction, and gently set the fixture down on the mattress sleep surface, ensuring that the footprint of the fixture does not extend beyond the edge of the mattress. The fixture shall be placed as

horizontal as possible, using the level to verify. If the bar makes contact with the top of the mattress sleep surface, even slightly, the mattress is considered to have failed the test.

(C) Repeat Steps (1) and (2) and at the remaining locations identified in 6.3.2.1(6).

(D) Repeat Steps (1) and (2) at a location away from the centerline most likely to fail (e.g., a very soft spot on the sleep surface or at a raised portion of the sleep surface). In the case of testing a raised portion of a sleep surface, position center of the fixture such that the bar is over the raised portion, to simulate the position of an infant's nose.

(E) In the event that the fixture is not resting in a nearly horizontal orientation, repeat the test procedure at that location by beginning again from paragraph (b)(19)(x)(A). However, if the test produces a fail even with the device tilted back away from the bar so as to raise it, then a fail can be recorded.

(20) Add the following paragraphs as section 6.4 of ASTM F2933–19:

(i) 6.4 Coil Spring Test.

(ii) 6.4.1 General—This test consists of dropping a specified weight repeatedly onto the mattress. The test assists in evaluating the structural integrity of a mattress with coil springs.

(iii) 6.4.2 Test Fixture:

(iv) 6.4.2.1 A guided free-fall impacting system machine (which keeps the upper surface of the impact mass parallel to the horizontal surface on which the crib is secured) (See Fig. 3).

(v) 6.4.2.2 A 30-lb (13.6-kg) impact mass (see Fig. 4 and Fig. 5).

(vi) 6.4.2.3 A 6-in. (150-mm) long gauge.

(vii) 6.4.2.4 An enclosed frame measuring 29 inches by 53 inches (737 mm by 1346 mm) for the purpose of restricting mattress movement. When testing full-size mattresses, a full-size crib meeting the requirements of ASTM F1169–19 would suffice.

(viii) 6.4.2.5 A ¾" piece of plywood or OSB that is rigidly supported along the perimeter.

(ix) 6.4.3 Test Method:

(x) 6.4.3.1 Place the mattress on the wooden support and inside the enclosed frame.

(xi) 6.4.3.2 Position geometric center of the impact mass above the geometric center of the test mattress.

(xii) 6.4.3.3 Adjust the distance between the top surface of the mattress and bottom surface of the impact mass to 6 in. (150 mm) (using the 6-in. (150-mm) long gauge, per 6.4.2.3) when the impact mass is in its highest position. Lock the impactor mechanism at this height and do not adjust the height during impacting to compensate for any change in distance as a result of the mattress compressing or the mattress support deforming or moving during impacting.

(xiii) 6.4.3.4 Allow the 30-lb (13.6-kg) impact mass to fall freely 250 times at the rate of one impact every 4 s. Load retraction shall not begin until at least 2 s after the start of the drop.

(xiv) 6.4.3.5 Repeat the step described in 6.4.3.4 at the other test locations shown in Fig. 6.

(21) Add the following Figures to section 6 of ASTM F2933–19:

**BILLING CODE 6355-01-P**

<sup>72</sup> Reprinted with permission, from ASTM F1169–19 Standard Consumer Safety Specification for Full-Size Baby Cribs, copyright ASTM International, 100 Barr Harbor Drive, West Conshohocken, PA 19428. A copy of the complete standard may be obtained from ASTM International, [www.astm.org](http://www.astm.org).

(i) Figure 2.

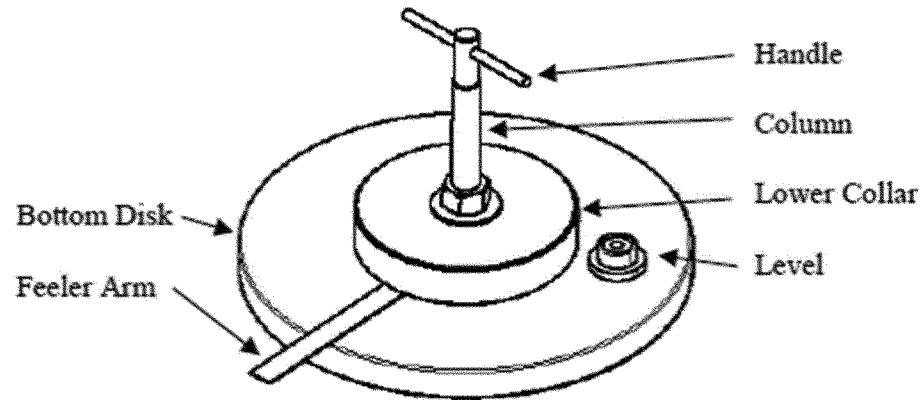

Figure 2. Mattress Firmness Test Fixture

(ii) Figure 3.

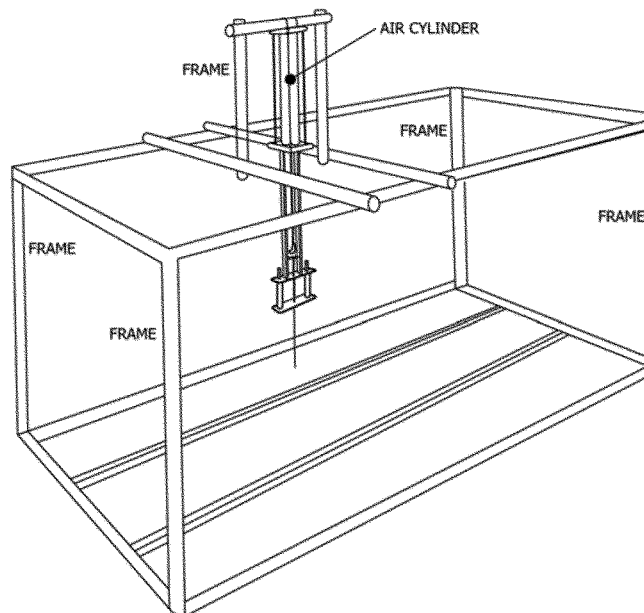

Figure 3. Typical free fall impacting system<sup>72</sup>

(iii) Figure 4.

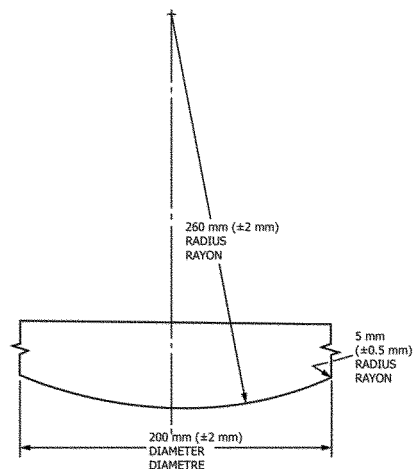

Figure 4. Profile of Impact mass<sup>72</sup>

(iv) Figure 5.

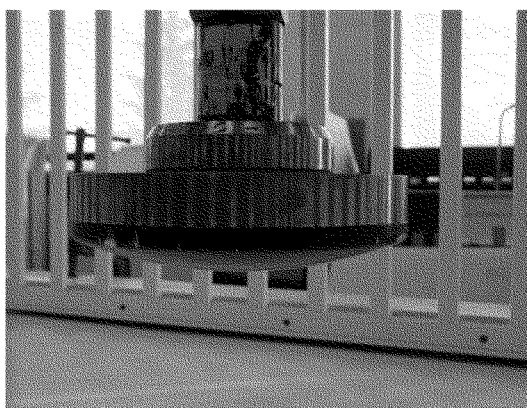

Figure 5. Photo of typical impact mass<sup>72</sup>

(v) Figure 6.

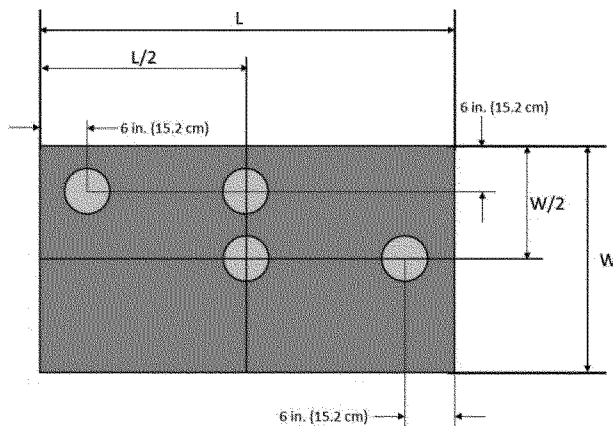

Figure 6. Impact test locations

(22) Instead of complying with sections 7.1 and 7.2 of ASTM F2933–19, comply with the following:

(i) 7.1 Each mattress and its retail package shall be marked or labeled clearly and legibly to indicate the following:

(ii) 7.1.1 The name, place of business (city, state, and mailing address, including zip code), and telephone number of the manufacturer, distributor, or seller.

(iii) 7.1.2 A code mark or other means that identifies the date (month and year at a minimum) of manufacture.

(iv) 7.2 The marking and labeling on the product shall be permanent.

(23) Do not comply with sections 7.2.1, 7.2.2, 7.2.2.1, 7.2.2.2, and 7.2.2.3 of ASTM F2933–19.

(24) Instead of complying with sections 7.3, 7.3.1, 7.3.2, and 7.3.3 of ASTM F2933–19, comply with the following:

(i) 7.3 Any upholstery labeling required by law shall not be used to meet the requirements of this section.

(ii) [Reserved]

(25) Instead of complying with sections 7.4 and 7.4.1 of ASTM F2933–19, comply with the following:

(i) 7.4 *Warning Design for Mattresses:*

(ii) 7.4.1 The warnings shall be easy to read and understand and be in the English language at a minimum.

(iii) 7.4.2 Any marking or labeling provided in addition to those required by this section shall not contradict or confuse the meaning of the required information, or be otherwise misleading to the consumer.

(iv) 7.4.3 The warnings shall be conspicuous and permanent.

(v) 7.4.4 The warnings shall conform to ANSI Z535.4—2011, American National Standard for Product Safety Signs and Labels, sections 6.1–6.4, 7.2–7.6.3, and 8.1, with the following changes.

(vi) 7.4.4.1 In sections 6.2.2, 7.3, 7.5, and 8.1.2, replace “should” with “shall.”

(vii) 7.4.4.2 In section 7.6.3, replace “should (when feasible)” with “shall.”

(viii) 7.4.4.3 Strike the word “safety” when used immediately before a color (e.g., replace “safety white” with “white”).

(ix) *Note 3*—For reference, ANSI Z535.1 provides a system for specifying safety colors.

(x) 7.4.5 The safety alert symbol “[Safety Alert Symbol]” and the signal word “WARNING” shall be at least 0.2 in. (5 mm) high. The remainder of the text shall be in characters whose upper case shall be at least 0.1 in. (2.5 mm), except where otherwise specified.

(xi) *Note 4*—For improved warning readability, typefaces with large height-to-width ratios, which are commonly identified as “condensed,” “compressed,” “narrow,” or similar should be avoided.

(xii) 7.4.6 *Message Panel Text Layout:*

(xiii) 7.4.6.1 The text shall be left aligned, ragged right for all but one-line text messages, which can be left aligned or centered.

(xiv) *Note 5*—Left aligned means that the text is aligned along the left margin, and, in the case of multiple columns of text, along the left side of each individual column. Please see FIG. 7 for examples of left aligned text.

(xv) 7.4.6.2 The text in each column needs to be arranged in list or outline format, with precautionary (hazard avoidance) statements preceded by bullet points. Multiple precautionary statements shall be separated by bullet points if paragraph formatting is used.

(xvi) 7.4.7 Example warnings in the format described in this section are shown in FIGS. 8, 9, and 10.

(26) Instead of complying with sections 7.5, 7.5.1, 7.5.2, 7.5.3, 7.5.3.1, and 7.5.3.2 of ASTM F2933–19, comply with the following:

(i) 7.5 *Warning Statements*—Each mattress shall have warning statements to address the following, at a minimum, unless otherwise specified. The blank in the mattress fit statement beginning with “If a gap is larger than,” needs to be filled with “1<sup>3</sup>/<sub>8</sub> in. (3.5 cm)” for full-size crib mattresses and “1 in. (2.5 cm)” for all other mattresses.

(ii) *Note 6*—Address means that verbiage other than what is shown can be used as long as the meaning is the same or information that is product-specific is presented.

#### SIDS AND SUFFOCATION HAZARDS

*ALWAYS* place baby on back to sleep to reduce the risks of SIDS and suffocation.

*Babies have suffocated:*

- On pillows, comforters, and extra padding

- in gaps between a wrong-size mattress, or extra padding, and side walls of product.

*NEVER* add soft bedding, padding, or an extra mattress.

*USE ONLY* one mattress at a time.

*DO NOT* cover the faces or heads of babies with a blanket or over-bundle them. Overheating can increase the risk of SIDS.

*ALWAYS* check mattress fit every time you change the sheets, by pushing mattress tight to one corner. Look for any gaps between the mattress and the

side walls. If a gap is larger than \_\_\_\_\_, the mattress does not fit—do not use it.

(iii) Renumber section 7.3.1 of ASTM F2933–19 to section 7.5.1.

(iv) In section 7.5.1, replace the reference to “7.3” with a reference to “7.5.”

(v) In section 7.5.1, replace the term “Only use” with the term “*USE ONLY*.”

(vi) Renumber section 7.3.2 of ASTM F2933–19 to section 7.5.2.

(vii) In section 7.5.2, replace the term “For non-full-size crib mattresses” with the term “For non-full-size crib mattresses and after-market mattresses for play yards and non-full-size cribs.”

(viii) In section 7.5.2, replace the reference to “7.3” with a reference to “7.5.”

(ix) In section 7.5.2, replace the term “Only use” with the term “*USE ONLY*.”

(x) Renumber section 7.3.3 of ASTM F2933–19 to section 7.5.3.

(xi) In section 7.5.3, replace the term “Additional manufacturers warnings may be included between the warnings specified in 7.3 and 7.4 if desired” with “Manufacturers are permitted to include additional warnings between the warnings specified in 7.5 and 7.6 if desired.”

(27) Instead of complying with sections 7.6, 7.6.1, 7.6.1.1, 7.6.1.2, or 7.7 of ASTM F 2933–19, comply with the following:

(i) 7.6 The following warning statement shall be included exactly as stated in this paragraph (b)(27)(i) and shall be located at the bottom of the warnings on each mattress:

*DO NOT* remove these important safety warnings.

(ii) 7.7 *Additional Marking and Warnings for After-Market Mattresses for Play Yards and Non-Full-Size Cribs*—The mattress shall have:

(iii) 7.7.1 All warnings added by the original manufacturer which are in addition to those required by this standard.

(iv) 7.7.2 Assembly/attachment instructions that were provided on the original mattress.

(v) 7.7.3 The specific brand(s) and model(s) number(s) of the product(s) in which it is intended to be used.

(vi) 7.7.4 *For Rigid Sided Rectangular Products*—the following statement shall appear exactly as stated in this paragraph (b)(27)(vi) (the blanks are to be filled in as appropriate).

This mattress measures \_\_\_\_\_ long, \_\_\_\_\_ wide, and \_\_\_\_\_ thick when measured from seam to seam.

(28) Add the following paragraphs as section 7.8 of ASTM F2933–19:

(i) 7.8 *Package Warnings.*

(ii) 7.8.1 The warnings and statements are not required on the retail

package if they are on the mattress and are visible in their entirety through the retail package. Cartons and other materials used exclusively for shipping the mattress are not considered retail packaging.

(iii) 7.8.2 Warning Statements—Each mattress' retail package shall have statements to address the following, at a minimum.

(iv) 7.8.2.1 All warnings included in section 7.5, as applicable.

(v) 7.8.2.2 All additional markings and warnings included in section 7.7, as applicable.

(29) Add the following figures to section 7 of ASTM F2933-19:

BILLING CODE 6355-01-P

(i) Figure 7.

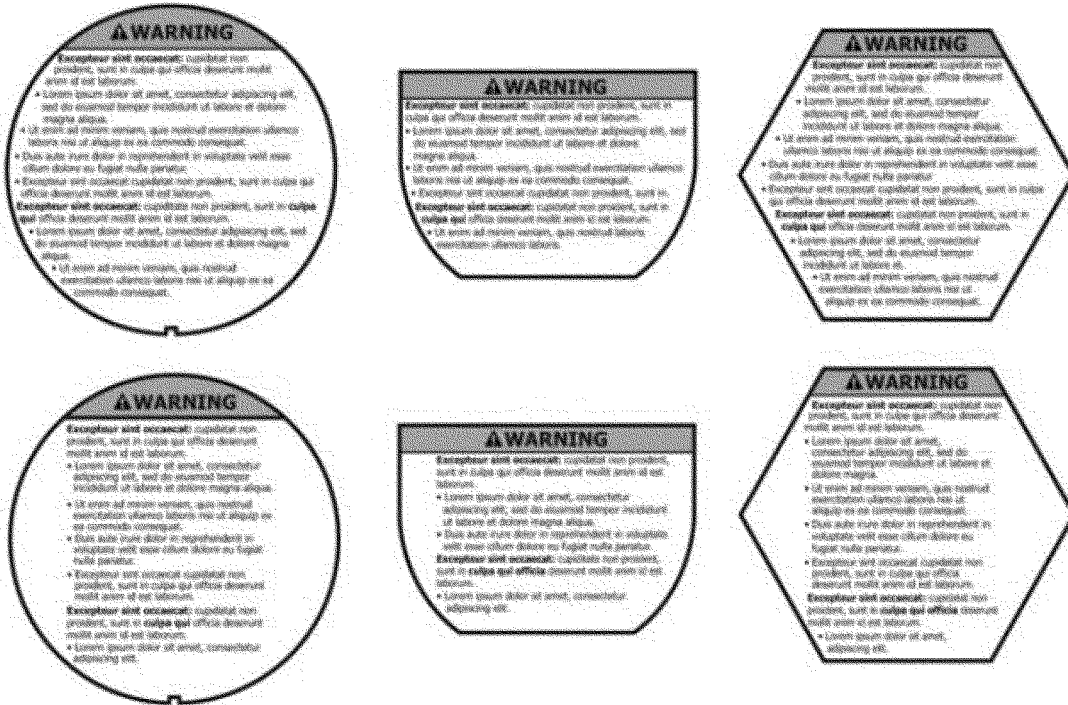

Figure 7. Examples of Left Aligned Text.

(ii) Figure 8.

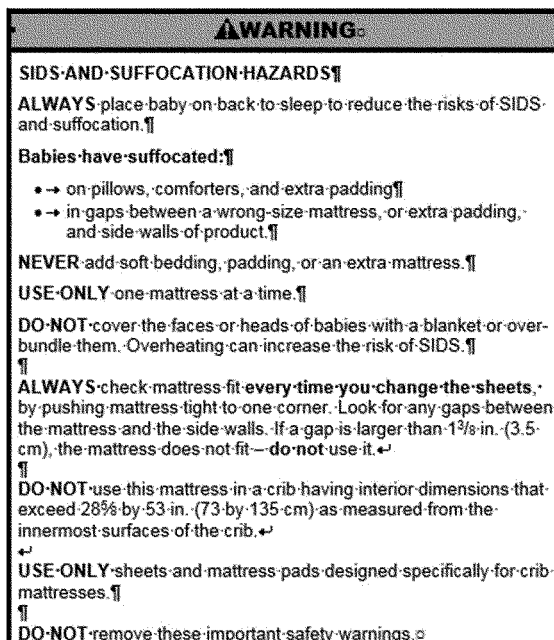

Figure 8. Example of warning label for Full-Size Crib Mattress.

(iii) Figure 9.



Figure 9. Example of warning label for After-Market Mattress for Mesh/Fabric Sided Products and Rigid Sided Non-Rectangular Products. Items italicized in brackets are to be added as appropriate.

(iv) Figure 10.

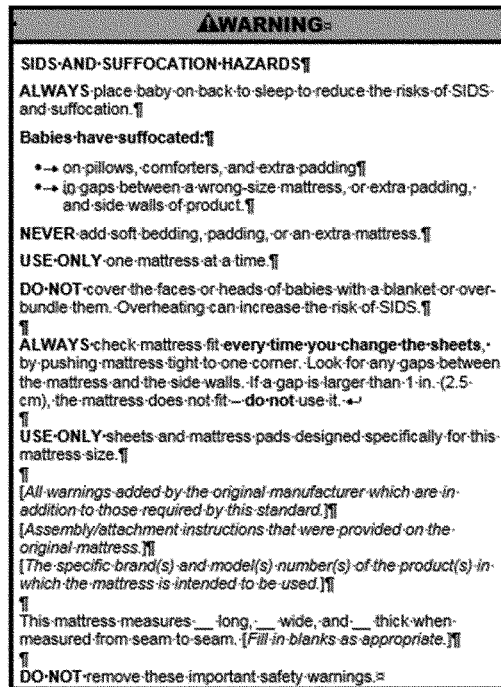

**Figure 10. Example of warning label for After-Market Mattress for Rigid Sided Rectangular Products.**

Items italicized in brackets, and blanks, are to be added or filled in as appropriate.

**BILLING CODE 6355-01-C**

(30) Renumber section 8 of ASTM F2933-19 to section 9.

(31) Add the following paragraphs to section 8 of ASTM F2933-19:

(i) 8. Instructional Literature.

(ii) 8.1 Instructions shall be provided with the mattress and shall be easy to read and understand, and shall be in the English language, at a minimum. These instructions shall include information on assembly, maintenance, cleaning, and use, where applicable.

(iii) 8.2 The instructions shall have statements to address the following, at a minimum.

(iv) 8.2.1 All warnings included in section 7.5, as applicable.

(v) 8.2.2 All additional markings and warnings included in section 7.7, as applicable.

(vi) 8.3 The warnings in the instructions shall meet the requirements specified in 7.4.4, 7.4.5, and 7.4.6, except that sections 6.4 and 7.2-7.6.3 of ANSI Z535.4 need not be applied. However, the signal word and safety alert symbol shall contrast with the background of the signal word panel, and the cautions and warnings shall contrast with the background of the instructional literature.

(vii) *Note 7*—For example, the signal word, safety alert symbol, and the warnings may be black letters on a white background, white letters on a black background, navy blue letters on an off-white background, or some other high-contrast combination.

(viii) 8.4 Any instructions provided in addition to those required by this section shall not contradict or confuse the meaning of the required information, or be otherwise misleading to the consumer.

(ix) *Note 8*—For additional guidance on the design of warnings for instructional literature, please refer to ANSI Z535.6, *American National Standard: Product Safety Information in Product Manuals, Instructions, and Other Collateral Materials*.

**Alberta E. Mills,**

*Secretary, Consumer Product Safety Commission.*

[FR Doc. 2020-22558 Filed 10-23-20; 8:45 am]

**BILLING CODE 6355-01-P**