

Commission issued an LEO prohibiting the entry of infringing beverage dispensing systems and components thereof and a CDO directed to respondent Anheuser-Busch LLC. *Id.*

On May 4, 2020, Heineken and ABI filed a joint petition to rescind the limited exclusion order and the cease and desist order based on a settlement agreement. The petition contains confidential and non-confidential versions of the Global Settlement Agreement between the parties. On May 26, 2020, the parties supplemented their petition to state that there are no other agreements, written or oral, express or implied between the parties concerning the subject matter of the investigation. See 19 CFR 210.76(a)(3).

Having reviewed the petition, as supplemented, and determined that it complies with Commission rules, the Commission has determined to institute a rescission proceeding and to grant the petition. The LEO and the CDO are hereby rescinded.

The rescission proceeding is terminated.

The Commission vote for this determination took place on June 3, 2020.

The authority for the Commission's determination is contained in section 337 of the Tariff Act of 1930, as amended (19 U.S.C. 1337), and in part 210 of the Commission's Rules of Practice and Procedure (19 CFR part 210).

By order of the Commission.

Issued: June 3, 2020.

**Lisa Barton,**

*Secretary to the Commission.*

[FR Doc. 2020-12362 Filed 6-5-20; 8:45 am]

**BILLING CODE 7020-02-P**

## DEPARTMENT OF JUSTICE

### Bureau of Alcohol, Tobacco, Firearms and Explosives

[OMB Number 1140-0098]

#### Agency Information Collection Activities; Proposed eCollection Comments Requested; Extension Without Change of a Currently Approved Collection; Prevent All Cigarette Trafficking (PACT) Act Registration Form—ATF Form 5070.1

**AGENCY:** Bureau of Alcohol, Tobacco, Firearms and Explosives, Department of Justice.

**ACTION:** 60-Day notice.

**SUMMARY:** The Department of Justice (DOJ), Bureau of Alcohol, Tobacco, Firearms and Explosives (ATF), will

submit the following information collection request to the Office of Management and Budget (OMB) for review and approval in accordance with the Paperwork Reduction Act of 1995. The proposed information collection (IC) is also being published to obtain comments from the public and affected agencies.

**DATES:** Comments are encouraged and will be accepted for 60 days until August 7, 2020.

**FOR FURTHER INFORMATION CONTACT:** If you have additional comments, regarding the estimated public burden or associated response time, suggestions, or need a copy of the proposed information collection instrument with instructions, or additional information, please contact: David Marshall, Operational Intelligence Division, internet Investigations Center either by mail at 99 New York Avenue NE, 90 K-250, Washington, DC 20226, by email at *David.Marshall@atf.gov*, or by telephone at 202-648-7118.

**SUPPLEMENTARY INFORMATION:** Written comments and suggestions from the public and affected agencies concerning the proposed collection of information are encouraged. Your comments should address one or more of the following four points:

- Evaluate whether the proposed collection of information is necessary for the proper performance of the functions of the agency, including whether the information will have practical utility;
- Evaluate the accuracy of the agency's estimate of the burden of the proposed collection of information, including the validity of the methodology and assumptions used;
- Evaluate whether and if so how the quality, utility, and clarity of the information to be collected can be enhanced; and
- Minimize the burden of the collection of information on those who are to respond, including through the use of appropriate automated, electronic, mechanical, or other technological collection techniques or other forms of information technology, *e.g.*, permitting electronic submission of responses.

#### Overview of This Information Collection

(1) *Type of Information Collection (check justification or form 83):* Extension without change of a currently approved collection.

(2) *The Title of the Form/Collection:* Prevent All Cigarette Trafficking (PACT) Act Registration Form.

(3) *The agency form number, if any, and the applicable component of the Department sponsoring the collection:* Form number (if applicable): ATF Form 5070.1.

*Component:* Bureau of Alcohol, Tobacco, Firearms and Explosives, U.S. Department of Justice.

(4) *Affected public who will be asked or required to respond, as well as a brief abstract:*

*Primary:* Business or other for-profit.

*Other (if applicable):* None.

*Abstract:* Any person who sells, transfers, or ships for profit cigarettes and/or smokeless tobacco in interstate commerce, must register with ATF using the Prevent All Cigarette Trafficking (PACT) Act Registration Form—ATF Form 5070.1.

(5) *An estimate of the total number of respondents and the amount of time estimated for an average respondent to respond:* An estimated 400 respondents will utilize the form annually, and it will take each respondent approximately 60 minutes to complete their responses.

(6) *An estimate of the total public burden (in hours) associated with the collection:* The estimated annual public burden associated with this collection is 400 hours, which is equal to 400 (# of respondents) \* 1 (# of responses per respondents) \* 1 (60 minutes or time taken to complete each response).

(7) *An Explanation of the Change in Estimates:* Due to an increase in both the wage and postage rates, the total public cost burden has risen from \$9,396 in 2017 to 13,542 currently.

*If additional information is required contact:* Melody Braswell, Department Clearance Officer, United States Department of Justice, Justice Management Division, Policy and Planning Staff, Two Constitution Square, 145 N Street NE, 3E.405A, Washington, DC 20530.

Dated: June 3, 2020.

**Melody Braswell,**

*Department Clearance Officer for PRA, U.S. Department of Justice.*

[FR Doc. 2020-12361 Filed 6-5-20; 8:45 am]

**BILLING CODE 4410-14-P**

## DEPARTMENT OF JUSTICE

### Antitrust Division

#### United States v. Odyssey Investment Partners Fund V, LP et al.; Proposed Final Judgment and Competitive Impact Statement

Notice is hereby given pursuant to the Antitrust Procedures and Penalties Act, 15 U.S.C. 16(b)–(h), that a proposed

Final Judgment, Stipulation, and Competitive Impact Statement have been filed with the United States District Court for the District of Columbia in *United States of America v. Odyssey Investment Partners Fund V, LP et al.*, Civil Action No. 20–cv–1614. On May 28, 2020, the United States filed a Complaint alleging that Communications & Power Industries Inc.’s proposed acquisition of General Dynamics SATCOM Technologies, Inc. would violate Section 7 of the Clayton Act, 15 U.S.C. 18. The proposed Final Judgment, filed at the same time as the Complaint, requires Communications & Power Industries to divest its subsidiary, CPI ASC Signal Division Inc., along with certain tangible and intangible assets.

Copies of the Complaint, proposed Final Judgment, and Competitive Impact Statement are available for inspection on the Antitrust Division’s website at <http://www.justice.gov/atr> and at the Office of the Clerk of the United States District Court for the District of Columbia. Copies of these materials may be obtained from the Antitrust Division upon request and payment of the copying fee set by Department of Justice regulations.

Public comment is invited within 60 days of the date of this notice. Such comments, including the name of the submitter, and responses thereto, will be posted on the Antitrust Division’s website, filed with the Court, and, under certain circumstances, published in the **Federal Register**. Comments should be directed to Katrina Rouse, Chief, Defense, Industrials, and Aerospace Section, Antitrust Division, Department of Justice, 450 Fifth Street NW, Suite 8700, Washington, DC 20530 (telephone: 202–307–0468).

**Suzanne Morris,**

*Chief, Pre-Merger and Division Statistics.*

#### **UNITED STATES DISTRICT COURT FOR THE DISTRICT OF COLUMBIA**

*United States of America, U.S. Department of Justice, Antitrust Division, 450 Fifth Street NW, Suite 8700, Washington, DC 20530, Plaintiff, v. Odyssey Investment Partners Fund V, LP, 590 Madison Ave., 39th Floor, New York, NY 10022; Communications and Power Industries LLC, 811 Hansen Way, Palo Alto, CA 94303; and General Dynamics Corporation, 11011 Sunset Hills Road, Reston, VA 20190, Defendants.*

Civil Action No. 20–cv–1614  
Judge: Hon. Thomas F. Hogan

#### **Complaint**

The United States of America (“United States”), acting under the direction of the Attorney General of the United States, brings this civil antitrust

action against Defendants Odyssey Investment Partners Fund V, LP (“Odyssey”), Communications and Power Industries LLC (“CPI”), and General Dynamics Corporation (“General Dynamics”) to enjoin CPI’s proposed acquisition of General Dynamics SATCOM Technologies, Inc. (“GD SATCOM”), a subsidiary of General Dynamics. The United States complains and alleges as follows:

#### **I. Nature of the Action**

1. Pursuant to a purchase agreement dated July 22, 2019, CPI intends to acquire GD SATCOM from its parent company, General Dynamics.

2. CPI and GD SATCOM are the only two significant suppliers of large (four meters in diameter and above) ground station antennas for geostationary satellites (hereinafter “large geostationary satellite antennas”) for use by the United States military and commercial customers in the United States. Large geostationary satellite antennas are a key component of communications networks utilized by the U.S. Department of Defense (“DoD”) as well as commercial customers, such as broadband internet suppliers, in areas that lack access to the main telecommunications grid.

3. Competition between CPI and GD SATCOM has led to lower prices, higher quality products, and innovative new solutions for large geostationary satellite antennas. The proposed merger would eliminate this competition and leave DoD and commercial customers without meaningful competitive alternatives, likely resulting in higher prices, lower quality, and diminished innovation in the development of these important products.

4. As a result, the proposed acquisition likely would substantially lessen competition in the market for the design, manufacture, and sale of large geostationary satellite antennas in the United States in violation of Section 7 of the Clayton Act, 15 U.S.C. 18.

#### **II. The Defendants**

5. Odyssey, a private equity fund managed by Odyssey Investment Partners, is a Delaware limited partnership with its headquarters in New York, New York. Odyssey Investment Partners has raised over \$5 billion since its inception and invests in a wide array of industries, including aerospace and defense.

6. CPI is a portfolio company of Odyssey. It is a Delaware corporation with its headquarters in Palo Alto, California. CPI is a global manufacturer of electronic components and subsystems focused primarily on

communications and defense markets. CPI had sales of approximately \$500 million in 2019 and sells satellite communication antennas through its subsidiary, CPI ASC Signal Division Inc. (“ASC Signal”), a business it acquired in 2017.

7. General Dynamics is a Delaware corporation with its headquarters in Reston, Virginia. General Dynamics’s subsidiary, GD SATCOM, designs, manufactures, and sells satellite communications systems used in commercial, defense, and scientific applications and provides related products such as amplifiers and antennas. GD SATCOM earned between \$200 million and \$300 million in revenues in 2019.

#### **III. Jurisdiction and Venue**

8. The United States brings this action under Section 15 of the Clayton Act, 15 U.S.C. 25, as amended, to prevent and restrain Defendants from violating Section 7 of the Clayton Act, 15 U.S.C. 18.

9. Defendants design, manufacture, and sell large geostationary satellite antennas throughout the United States, and their activities in these areas substantially affect interstate commerce. This Court therefore has subject matter jurisdiction over this action pursuant to Section 15 of the Clayton Act, 15 U.S.C. 25, and 28 U.S.C. 1331, 1337(a), and 1345.

10. Defendants have consented to venue and personal jurisdiction in this judicial district. Venue is therefore proper in this district under Section 12 of the Clayton Act, 15 U.S.C. 22 and under 28 U.S.C. 1391(c).

#### **IV. Large Geostationary Satellite Antennas**

##### *A. Background*

11. Satellite communications networks enable secure communications links in remote areas that lack access to the main telecommunications grid. For example, DoD uses satellite communications networks to communicate with military bases in theaters of war, where access to the communications grid may be intermittent or even non-existent. Similarly, where it is too expensive to run traditional communications lines, commercial network operators provide satellite communications networks that individual users—or clusters of users in a central location—can use to access the internet, television, and voice communications services.

12. Both commercial and military satellite communications networks operate in the same way: Information is

transmitted from a remote user through a satellite in orbit and back down through a ground station that is connected to a traditional communications grid. This process is reversed as information returns to the remote user. At both ends of the satellite communication link, there must be an antenna that can “see” the satellite(s) with which the ground stations are interfacing.

13. The satellite is the most critical, and expensive, element of a satellite communications network. Satellite-based design constraints, such as the power of the transmission signal (which is directly impacted by limitations on size and weight) and the orbit in which the satellite will operate, thus drive other significant design decisions for the entire satellite communications network.

14. The other key component of a satellite communications network is the ground station antenna, which connects the satellite to the communications grid. As shown below, the ground station antenna consists of a parabolic dish, the structure on which the dish is mounted, and any motors or other equipment needed to move, or “point,” the dish at the satellite(s) in its network.

BILLING CODE 4410-11-P

**Figure 1. Diagram of a Large Geostationary Satellite Antenna**

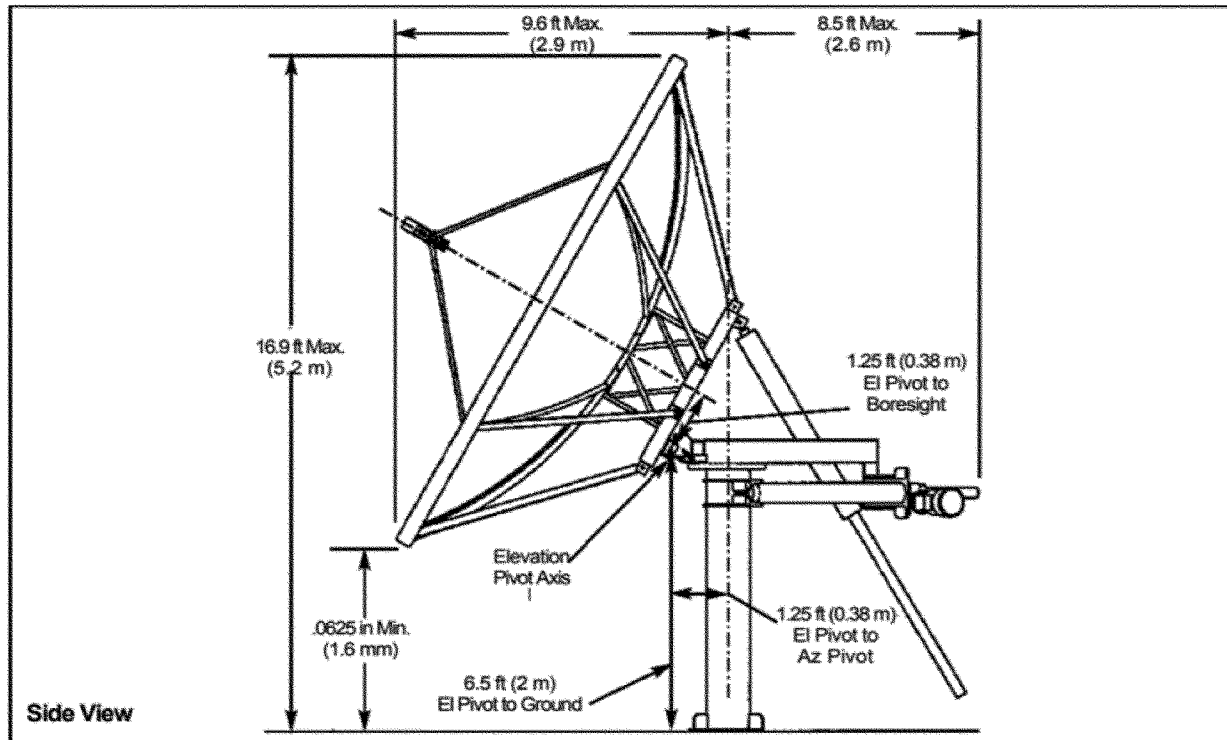

Source: ASC Signal Foundation Specifications  
For 4.5-4.6 meter Earth Station Antennas

BILLING CODE 4410-11-C

15. Several characteristics differentiate ground station antennas, but the two most important are the size of the antenna (which is typically measured by the diameter of its parabolic dish) and the ability of the antenna to track satellites that change their position relative to the Earth (as described below, some antennas remain pointed in the same direction while others track satellites as they cross the sky).

16. Antenna size is important because larger antennas can receive fainter signals (*i.e.*, signals impacted by rain, clouds, or other atmospheric conditions) than smaller antennas. As a result, satellite networks using larger antennas are more reliable than networks using

smaller antennas. Additionally, because larger antennas can receive fainter signals, the power requirements for the transmitting satellite (which must be supplied through batteries and/or solar generation) are diminished as compared to transmission to smaller antennas. Satellites for larger antennas therefore need not be as large or expensive as satellites for smaller antennas. Larger antennas thus decrease the overall cost of the satellite communications system.

17. The other major factor differentiating between types of ground station antennas is their ability to track satellites that change their position relative to the Earth. For example, satellites in geostationary orbit remain in a fixed position relative to the Earth's

rotation and are more than 20,000 miles above Earth. Antennas for geostationary satellites are therefore “fixed” and point in one direction. Low-earth orbit (“LEO”) and mid-earth orbit (“MEO”) satellites, by contrast, are multiple thousands of miles closer to earth and rotate the earth every 70 minutes. LEO and MEO satellites thus frequently “cross” the sky as they orbit and antennas used to communicate with them must be “full-motion” in order to track the LEO and MEO satellites as they move relative to the antennas’ positions. While full motion antennas duplicate some of the capabilities of fixed antennas, they are typically only used for LEO and MEO satellites because they are significantly more

expensive due to the motors and structural design elements necessary to ensure accurate full-motion pointing. Fixed antennas are thus more cost-effective than full-motion antennas.

### *B. Relevant Markets*

#### 1. Product Market

18. For DoD customers, satellite communications networks provide vital communications links for the battlefield and other remote locations. For many uses, DoD requires large geostationary satellite antennas in order to guarantee reliable communications connections. DoD cannot switch to smaller geostationary antennas without compromising the reliability and usefulness of its network. Because switching to smaller geostationary antennas would effectively render a satellite communications network unfit for its intended use, DoD is unlikely to switch to smaller geostationary antennas in response to a small but significant increase in price for large geostationary satellite antennas.

19. Commercial customers—whose reliability requirements are not as rigid as DoD's—are also unlikely to switch to smaller geostationary antennas in the event of a small but significant increase in price for large geostationary satellite antennas because, like DoD, doing so would decrease the reliability of their network. Further, switching to smaller geostationary antennas would require a satellite communications network with a larger—and significantly more expensive—satellite at its core, thus increasing the overall cost of the network.

20. Similarly, DoD and commercial customers with geostationary satellites are unlikely to switch from fixed to full-motion antennas—like those used for MEO and LEO satellites—in response to a small but significant increase in price of fixed antennas. Even when full-motion antennas have similar capabilities to fixed antennas, they are significantly more expensive due to the additional motors and equipment necessary to ensure accurate full-motion pointing.

21. For the foregoing reasons, customers will not substitute to smaller or full-motion antennas in response to a small but significant and non-transitory increase in the price of large geostationary satellite antennas. Accordingly, the design, manufacture, and sale of large geostationary satellite antennas is a relevant product market and line of commerce under Section 7 of the Clayton Act, 15 U.S.C. 18.

#### 2. Geographic Market

22. For national security reasons, DoD prefers domestic suppliers of large geostationary satellite antennas when it is deciding on potential antenna sources. Similarly, commercial customers prefer domestic suppliers of large geostationary satellite antennas, in part because they resell network access to DoD and other government customers that prefer to avoid having foreign suppliers for components in the transmission chain for sensitive national security-related information. For these reasons, neither DoD nor commercial customers are likely to turn to any foreign suppliers in the face of a small but significant and non-transitory price increase by domestic suppliers of large geostationary satellite antennas.

23. The United States is therefore a relevant geographic market within the meaning of Section 7 of the Clayton Act, 15 U.S.C. 18.

### *C. Anticompetitive Effects of the Proposed Transaction*

24. CPI, through its subsidiary ASC Signal, and GD SATCOM are the only two significant suppliers that design, manufacture, and sell large geostationary satellite antennas in the United States. The merger would give the combined firm an effective monopoly, leaving customers, including DoD, without a meaningful competitive alternative for this critical component of satellite communications networks.

25. CPI and GD SATCOM compete for sales of large geostationary satellite antennas on the basis of quality, price, and contractual terms such as delivery times. This competition has resulted in higher quality, lower prices, and shorter delivery times. The combination of CPI and GD SATCOM would eliminate this competition and its future benefits to customers, including DoD. Post-acquisition, the merged firm likely would have the incentive and ability to increase prices and offer less favorable contractual terms.

26. Competition between CPI and GD SATCOM has also fostered important industry innovation, leading to antennas that are more durable, can withstand more extreme environments, and operate at higher bandwidths. The combination of CPI and GD SATCOM would eliminate this competition and its future benefits to customers, including DoD. Post-acquisition, the merged firm likely would have less incentive to engage in research and development efforts that lead to innovative and high-quality products.

27. The proposed acquisition, therefore, likely would substantially

lessen competition in the design, manufacture, and sale of large geostationary satellite antennas in the United States in violation of Section 7 of the Clayton Act, 15 U.S.C. 18.

### *D. Difficulty of Entry*

28. Entry of additional competitors into the market for the design, manufacture, and sale of large geostationary satellite antennas in the United States is unlikely to prevent the harm to competition that is likely to result if the proposed acquisition is consummated. Production facilities for large geostationary satellite antennas require a substantial investment in both capital equipment and human resources. A new entrant would need to set up a factory to produce parabolic dishes, design the complex electronic assemblies and components necessary to point the antenna, and build assembly lines and testing facilities. Engineering and research personnel would need to be assigned to design, test, and troubleshoot the complex manufacturing process that is necessary to produce large geostationary satellite antennas. Any new products manufactured by such an entrant would also require extensive testing and qualification before they could be used by the U.S. military. Accordingly, entry would be costly and time-consuming.

29. As result of these barriers, entry into the market for the design, manufacture, and sale of large geostationary satellite antennas in the United States would not be timely, likely, or sufficient to defeat the anticompetitive effects likely to result from CPI's acquisition of GD SATCOM.

### **V. Violations Alleged**

30. CPI's acquisition of GD SATCOM likely would substantially lessen competition in the design, manufacture, and sale of large geostationary satellite antennas in the United States in violation of Section 7 of the Clayton Act, 15 U.S.C. 18.

31. Unless enjoined, the acquisition likely would have the following anticompetitive effects, among others, related to the relevant market:

(a) Actual and potential competition between CPI and GD SATCOM would be eliminated;

(b) competition generally likely would be substantially lessened; and

(c) prices likely would increase, quality and innovation would likely decrease, and contractual terms likely would be less favorable to customers.

### **VI. Request for Relief**

32. The United States requests that this Court:

(a) Adjudge and decree that CPI's acquisition of GD SATCOM would be unlawful and violate Section 7 of the Clayton Act, 15 U.S.C. 18;

(b) preliminarily and permanently enjoin and restrain Defendants and all persons acting on their behalf from consummating the proposed acquisition of GD SATCOM by CPI, or from entering into or carrying out any other contract, agreement, plan, or understanding, the effect of which would be to combine CPI with GD SATCOM;

(c) award the United States its costs for this action; and

(d) award the United States such other and further relief as the Court deems just and proper.

Dated: May 28, 2020

Respectfully submitted,

FOR PLAINTIFF UNITED STATES:

---

Makan Delrahim (D.C. Bar #457795)  
Assistant Attorney General

---

Bernard A. Nigro, JR. (D.C. Bar #412357)  
Principal Deputy Assistant Attorney General

---

Alexander P. Okuliar (D.C. Bar # 481103)  
Deputy Assistant Attorney General

---

Kathleen S. O'Neill  
Senior Director of Investigations & Litigation

---

Katrina H. Rouse (D.C. Bar #1013035)  
Chief Defense, Industrials, and Aerospace Section

---

Jay D. Owen\*  
Assistant Chief, Defense, Industrials, and Aerospace Section

---

Rebecca Valentine (D.C. Bar #989607)  
Kevin Quin (D.C. Bar #415268)  
Attorneys for the United States, Defense, Industrials, and Aerospace Section, U.S. Department of Justice, Antitrust Division, 450 Fifth Street NW, Suite 8700, Washington, D.C. 20530, Telephone: (202) 598-2987, Facsimile: (202) 514-9033, Email: jay.owen@usdoj.gov

\*Lead Attorney to be Noticed

**UNITED STATES DISTRICT COURT FOR THE DISTRICT OF COLUMBIA**

*United States of America, Plaintiff, v. Odyssey Investment Partners Fund V, LP; Communications & Power LLC, and General Dynamics Corporation, Defendants.*

Civil Action No. 20-cv-1614

Judge: Hon. Thomas F. Hogan

**Proposed Final Judgment**

Whereas, Plaintiff, United States of America, filed its Complaint on May 28, 2020, the United States and Defendants, Odyssey Investment Partners Fund V, LP ("Odyssey"), Communications & Power Industries LLC ("CPI"), and General Dynamics Corporation ("General Dynamics"), by their respective attorneys, have consented to

entry of this Final Judgment without trial or adjudication of any issue of fact or law and without this Final Judgment constituting any evidence against or admission by a party regarding any issue of fact or law;

And whereas, Defendants agree to be bound by the provisions of this Final Judgment pending its approval by the Court;

And whereas, the essence of this Final Judgment is the prompt and certain divestiture of certain rights or assets by Defendants to assure that competition is not substantially lessened;

And whereas, Defendants agree to make a divestiture for the purpose of remedying the loss of competition alleged in the Complaint;

And whereas, Defendants represent that the divestiture and other relief required by this Final Judgment can and will be made and that Defendants will not later raise a claim of hardship or difficulty as grounds for asking the Court to modify any provision of this Final Judgment;

Now therefore, before any testimony is taken, without trial or adjudication of any issue of fact or law, and upon consent of the parties, *it is ordered, adjudged, and decreed:*

**I. Jurisdiction**

The Court has jurisdiction over the subject matter of and each of the parties to this action. The Complaint states a claim upon which relief may be granted against Defendants under Section 7 of the Clayton Act, as amended (15 U.S.C. 18).

**II. Definition**

As used in this Final Judgment:

A. "Acquirer" means the entity to whom Defendants divest the Divestiture Assets.

B. "Odyssey" means Defendant Odyssey Investment Partners Fund V, LP, a Delaware limited partnership with its headquarters in New York, New York, its successors and assigns, and its subsidiaries, divisions, groups, affiliates, including Odyssey Investment Partners, partnerships, and joint ventures, and their directors, officers, managers, agents, and employees.

C. "Odyssey Investment Partners" means Odyssey Investment Partners, LLC, an affiliate of Odyssey and a Delaware limited liability company with its headquarters in New York, New York, its successors and assigns, and its subsidiaries, divisions, groups, affiliates, partnerships, and joint ventures, and their directors, officers, managers, agents and employees.

D. "CPI" means Defendant Communications & Power Industries

LLC, a Delaware limited liability company with its headquarters in Palo Alto, California, its successors and assigns, and its subsidiaries, divisions, groups, affiliates, partnerships, and joint ventures, and their directors, officers, managers, agents, and employees. As used in this definition, the terms subsidiaries, divisions, groups, affiliates, partnerships, and joint ventures refer to any person or entity in which CPI holds twenty-five (25) percent or more total ownership or control.

E. "General Dynamics" means Defendant General Dynamics Corporation, a Delaware corporation with its headquarters in Reston, Virginia, its successors and assigns, and its subsidiaries, divisions, groups, affiliates, partnerships, and joint ventures, and their directors, officers, managers, agents, and employees.

F. "GD SATCOM" means General Dynamics SATCOM Technologies, Inc., a Delaware corporation with its headquarters in Fairfax, Virginia, its successors and assigns, and its subsidiaries, divisions, groups, affiliates, partnerships, and joint ventures, and their directors, officers, managers, agents, and employees. GD SATCOM is a wholly-owned subsidiary of General Dynamics.

G. "ASC Signal" means CPI ASC Signal Division Inc., a Delaware corporation with its headquarters in Plano, Texas, its successors and assigns, and its subsidiaries, divisions, groups, affiliates, partnerships, and joint ventures, and their directors, officers, managers, agents, and employees. ASC Signal is a wholly-owned subsidiary of CPI.

H. "Divestiture Assets" means ASC Signal, including but not limited to:

1. The support facility located at 1120 Jupiter Road, Suite 102, Plano, Texas 75074;

2. The manufacturing facility located at 606 Beech Street West, Whitby, Ontario, Canada L1N 0E7;

3. The testing facility located at 9860 Heron Rd., Ashburn, Ontario, Canada L0B 1A0;

4. The testing facility located at 1411 CR 2740, Caddo Mills, Texas 75135;

5. All tangible assets related to or used in connection with ASC Signal, including, but not limited to: Research and development activities; all manufacturing equipment, tooling and fixed assets, personal property, inventory, office furniture, materials, supplies, and other tangible property; all licenses, permits, certifications, and authorizations issued by any governmental organization; all contracts, teaming arrangements,

agreements, leases, commitments, certifications, and understandings, including supply agreements and development and production contracts; all customer lists, contracts, accounts, and credit records; all repair and performance records; and all other records; and

6. All intangible assets related to or used in connection with ASC Signal, including, but not limited to: All patents; licenses and sublicenses; intellectual property; copyrights; trademarks, trade names, service marks, and service names; technical information; computer software (including software developed by third parties), and related documentation; customer relationships, agreements, and contracts; know-how; trade secrets; drawings; blueprints; designs; design protocols; specifications for materials; specifications for parts and devices; safety procedures for the handling of materials and substances; quality assurance and control procedures; design tools and simulation capability; all manuals and technical information ASC Signal provides to its own employees, customers, suppliers, agents, or licensees; and all research data concerning historic and current research and development efforts, including, but not limited to, designs of experiments, and the results of successful and unsuccessful designs and experiments.

I. "Relevant Personnel" means all full-time, part-time, or contract employees of (i) ASC Signal, and (ii) all additional full-time, part-time, or contract employees of CPI, wherever located, primarily involved in the design, manufacture, or sale of geostationary antennas larger than four meters in diameter, including, but not limited to, the reflector, pedestal, and tracking and control mechanisms used in antennas. Notwithstanding the foregoing, Relevant Personnel does not include employees of CPI primarily engaged in human resources, legal, or other general or administrative support functions.

J. "Regulatory Approvals" means (i) any approvals or clearances pursuant to filings with the Committee on Foreign Investment in the United States ("CFIUS"), or under antitrust or competition laws required for the Transaction to proceed; and (ii) any approvals or clearances pursuant to filings with CFIUS, or under antitrust, competition, or other U.S. or international laws required for Acquirer's acquisition of the Divestiture Assets to proceed.

K. "Transaction" means the proposed acquisition of GD SATCOM by CPI.

### III. Applicability

A. This Final Judgment applies to Odyssey, CPI, and General Dynamics, as defined above, and all other persons, in active concert or participation with any Defendant, who receive actual notice of this Final Judgment.

B. If, prior to complying with Section IV and Section V of this Final Judgment, CPI sells or otherwise disposes of all or substantially all of its assets or of lesser business units that include the Divestiture Assets, CPI must require the purchaser to be bound by the provisions of this Final Judgment. CPI need not obtain such an agreement from Acquirer.

### IV. Divestiture

A. CPI is ordered and directed, within the later of sixty (60) calendar days after the Court's entry of the Hold Separate Stipulation and Order in this matter, or thirty (30) calendar days after Regulatory Approvals have been received, to divest the Divestiture Assets in a manner consistent with this Final Judgment to an Acquirer acceptable to the United States, in its sole discretion. The United States, in its sole discretion, may agree to one or more extensions of this time period not to exceed ninety (90) calendar days in total, and will notify the Court of any extensions. CPI agrees to use its best efforts to divest the Divestiture Assets as expeditiously as possible.

B. In accomplishing the divestiture ordered by this Final Judgment, CPI promptly must make known, by usual and customary means, the availability of the Divestiture Assets. CPI must inform any person making an inquiry regarding a possible purchase of the Divestiture Assets that the Divestiture Assets are being divested in accordance with this Final Judgment and must provide that person with a copy of this Final Judgment. CPI must offer to furnish to all prospective Acquirers, subject to customary confidentiality assurances, all information and documents relating to the Divestiture Assets customarily provided in a due-diligence process; provided, however, that CPI need not provide information or documents subject to the attorney-client privilege or work-product doctrine. CPI must make this information available to the United States at the same time that the information is made available to any other person.

C. CPI must cooperate with and assist Acquirer in identifying and hiring all Relevant Personnel, including:

1. Within ten (10) business days following the filing of the Complaint in this matter, CPI must identify all

Relevant Personnel to Acquirer and the United States, including by providing organization charts covering all Relevant Personnel.

2. Within ten (10) business days following receipt of a request by Acquirer or the United States, CPI must provide to Acquirer and the United States the following additional information related to Relevant Personnel: Name; job title; current salary and benefits including most recent bonus paid, aggregate annual compensation, current target or guaranteed bonus, if any, and any other payments due to or promises made to the employee; descriptions of reporting relationships, past experience, responsibilities, and training and educational histories; lists of all certifications; and all job performance evaluations. If CPI is barred by any applicable laws from providing any of this information, within ten (10) business days following receipt of the request, CPI must provide the requested information to the full extent permitted by law and also must provide a written explanation of CPI's inability to provide the remaining information.

3. At the request of Acquirer, CPI must promptly make Relevant Personnel available for private interviews with Acquirer during normal business hours at a mutually agreeable location or via teleconference or videoconference.

4. Defendants must not interfere with any efforts by Acquirer to employ any Relevant Personnel. Interference includes but is not limited to offering to increase the salary or improve the benefits of Relevant Personnel unless the offer is part of a company-wide increase in salary or benefits that was announced prior to August 5, 2019. Defendants' obligations under this paragraph will expire six (6) months after the divestiture of the Divestiture Assets pursuant to this Final Judgment.

5. For Relevant Personnel who elect employment with Acquirer within six (6) months of the date on which the Divestiture Assets are divested to Acquirer, CPI must waive all non-compete and non-disclosure agreements, vest all unvested pension and other equity rights, and provide all benefits that those Relevant Personnel otherwise would have been provided had the Relevant Personnel continued employment with CPI, including but not limited to any retention bonuses or payments CPI may maintain reasonable restrictions on disclosure by Relevant Personnel of CPI's proprietary non-public information that is unrelated to ASC Signal and not otherwise required to be disclosed by this Final Judgment.

6. For a period of twelve (12) months from the date on which the Divestiture Assets are divested to Acquirer, Defendants may not solicit to hire Relevant Personnel who were hired by Acquirer within six (6) months of the date on which the Divestiture Assets are divested to Acquirer unless (a) an individual is terminated or laid off by Acquirer or (b) Acquirer agrees in writing that Defendants may solicit to hire that individual. Nothing in this paragraph prohibits Defendants from advertising employment openings using general solicitations or advertisements.

D. CPI must permit prospective Acquirers of the Divestiture Assets to have reasonable access to make inspections of the physical facilities and access to all environmental, zoning, and other permit documents and information, and all financial, operational, or other documents and information customarily provided as part of a due diligence process.

E. CPI must warrant to Acquirer that each asset to be divested will be fully operational and without material defect on the date of sale.

F. Defendants must not take any action that will impede in any way the permitting, operation, or divestiture of the Divestiture Assets.

G. CPI must assign, subcontract, or otherwise transfer all contracts, agreements, and relationships related to the Divestiture Assets, including all supply and sales contracts, to Acquirer, *provided however*, that for any contracts or agreements that require the consent of another party to sign, subcontract, or otherwise transfer, CPI must use best efforts to accomplish this assignment, subcontracting or other transfer. Defendants must not interfere with any negotiations between Acquirer and a contracting party.

H. At the option of Acquirer, and subject to approval by the United States in its sole discretion, on or before the date on which the Divestiture Assets are divested to Acquirer, CPI must enter into a contract to provide transition services for back office, human resource, and information technology services and support for ASC Signal for a period of up to twelve (12) months on terms and conditions reasonably related to market conditions for the provision of the transition services. The United States, in its sole discretion, may approve one or more extensions of this contract for transition services, for a total of up to an additional six (6) months. If Acquirer seeks an extension of the term of this contract for transition services, CPI must notify the United States in writing at least three (3) months prior to the date the contract

expires. Acquirer may terminate a contract for transition services without cost or penalty at any time upon commercially reasonable notice. The employee(s) of CPI tasked with providing these transition services must not share any competitively sensitive information of Acquirer with any other employee of CPI.

I. CPI must warrant to Acquirer that there are no material defects in the environmental, zoning, or other permits pertaining to the operation of the Divestiture Assets. Following the sale of the Divestiture Assets, Defendants must not undertake, directly or indirectly, any challenges to the environmental, zoning, or other permits relating to the operation of the Divestiture Assets.

J. Unless the United States otherwise consents in writing, the divestiture pursuant to Section IV or by a Divestiture Trustee appointed pursuant to Section V of this Final Judgment must include the entire Divestiture Assets, and must be accomplished in such a way as to satisfy the United States, in its sole discretion, that the Divestiture Assets can and will be used by Acquirer as part of a viable, ongoing business of the design, manufacture, and sale of large ground station antennas for geostationary satellites, and will remedy the competitive harm alleged in the Complaint. The divestiture, whether pursuant to Section IV or Section V of this Final Judgment,

(1) must be made to an Acquirer that, in the United States' sole judgment, has the intent and capability (including the necessary managerial, operational, technical, and financial capability) of competing effectively in the business of the design, manufacture, and sale of large ground station antennas for geostationary satellites; and

(2) must be accomplished so as to satisfy the United States, in its sole discretion, that none of the terms of any agreement between an Acquirer and CPI give CPI the ability unreasonably to raise Acquirer's costs, to lower Acquirer's efficiency, or otherwise to interfere in the ability of Acquirer to compete effectively.

K. If any term of an agreement between CPI and Acquirer to effectuate the divestiture required by this Final Judgment varies from a term of this Final Judgment then, to the extent that CPI cannot fully comply with both, this Final Judgment determines CPI's obligations.

#### **V. Appointment of Divestiture Trustee**

A. If CPI has not divested the Divestiture Assets within the period specified in Paragraph IV(A), CPI must immediately notify the United States of that fact in writing. Upon application of the United States, the Court will appoint a Divestiture Trustee selected by the

United States and approved by the Court to effect the divestiture of the Divestiture Assets.

B. After the appointment of a Divestiture Trustee by the Court, only the Divestiture Trustee will have the right to sell the Divestiture Assets. The Divestiture Trustee will have the power and authority to accomplish the divestiture to an Acquirer acceptable to the United States, in its sole discretion, at a price and on terms as are then obtainable upon reasonable effort by the Divestiture Trustee, subject to the provisions of Sections IV, V, and VI of this Final Judgment, and will have other powers as the Court deems appropriate. Subject to Paragraph V(D) of this Final Judgment, the Divestiture Trustee may hire at the cost and expense of CPI any agents or consultants, including, but not limited to, investment bankers, attorneys, and accountants, who will be solely accountable to the Divestiture Trustee, reasonably necessary in the Divestiture Trustee's judgment to assist in the divestiture. Any such agents or consultants will serve on such terms and conditions as the United States approves, including confidentiality requirements and conflict of interest certifications.

C. Defendants may not object to a sale by the Divestiture Trustee on any ground other than malfeasance by the Divestiture Trustee. Objections by Defendants must be conveyed in writing to the United States and the Divestiture Trustee within ten (10) calendar days after the Divestiture Trustee has provided the notice required under Section VI.

D. The Divestiture Trustee will serve at the cost and expense of CPI pursuant to a written agreement, on such terms and conditions as the United States approves, including confidentiality requirements and conflict of interest certifications. The Divestiture Trustee will account for all monies derived from the sale of the assets sold by the Divestiture Trustee and all costs and expenses so incurred. After approval by the Court of the Divestiture Trustee's accounting, including fees for any of its services yet unpaid and those of any agents and consultants retained by the Divestiture Trustee, all remaining money will be paid to CPI and the trust will then be terminated. The compensation of the Divestiture Trustee and any agents or consultants retained by the Divestiture Trustee must be reasonable in light of the value of the Divestiture Assets and based on a fee arrangement that provides the Divestiture Trustee with incentives based on the price and terms of the divestiture and the speed with which it

is accomplished, but the timeliness of the divestiture is paramount. If the Divestiture Trustee and CPI are unable to reach agreement on the Divestiture Trustee's or any agents' or consultants' compensation or other terms and conditions of engagement within fourteen (14) calendar days of the appointment of the Divestiture Trustee, the United States may, in its sole discretion, take appropriate action, including making a recommendation to the Court. Within three (3) business days of hiring any agent or consultant, the Divestiture Trustee must provide written notice of the hiring and rate of compensation to CPI and the United States.

E. CPI must use its best efforts to assist the Divestiture Trustee in accomplishing the required divestiture. The Divestiture Trustee and any agents or consultants retained by the Divestiture Trustee must have full and complete access to the personnel, books, records, and facilities of the business to be divested, and CPI must provide or develop financial and other information relevant to such business as the Divestiture Trustee may reasonably request, subject to reasonable protection for trade secrets; other confidential research, development, or commercial information; or any applicable privileges. Defendants may not take any action to interfere with or impede the Divestiture Trustee's accomplishment of the divestiture.

F. After appointment, the Divestiture Trustee will file monthly reports with the United States setting forth the Divestiture Trustee's efforts to accomplish the divestiture ordered by this Final Judgment. Reports must include the name, address, and telephone number of each person who, during the preceding month, made an offer to acquire, expressed an interest in acquiring, entered into negotiations to acquire, or was contacted or made an inquiry about acquiring, any interest in the Divestiture Assets and will describe in detail each contact with any such person. The Divestiture Trustee will maintain full records of all efforts made to divest the Divestiture Assets.

G. If the Divestiture Trustee has not accomplished the divestiture ordered by this Final Judgment within six months of appointment, the Divestiture Trustee must promptly file with the Court a report setting forth: (1) The Divestiture Trustee's efforts to accomplish the required divestiture; (2) the reasons, in the Divestiture Trustee's judgment, why the required divestiture has not been accomplished; and (3) the Divestiture Trustee's recommendations. To the extent such report contains information

that the Divestiture Trustee deems confidential, such report will not be filed in the public docket of the Court. The Divestiture Trustee will at the same time furnish such report to the United States, which will have the right to make additional recommendations to the Court consistent with the purpose of the trust. The Court thereafter may enter such orders as it deems appropriate to carry out the purpose of this Final Judgment, which, if necessary, may include extending the trust and the term of the Divestiture Trustee's appointment by a period requested by the United States.

H. If the United States determines that the Divestiture Trustee is not acting diligently or in a reasonably cost-effective manner, the United States may recommend that the Court appoint a substitute Divestiture Trustee.

#### **VI. Notice of Proposed Divestiture**

A. Within two (2) business days following execution of a definitive divestiture agreement, CPI or the Divestiture Trustee, whichever is then responsible for effecting the divestiture required herein, must notify the United States of a proposed divestiture required by this Final Judgment. If the Divestiture Trustee is responsible for effecting the divestiture, the Divestiture Trustee also must notify Defendants. The notice must set forth the details of the proposed divestiture and list the name, address, and telephone number of each person not previously identified who offered or expressed an interest in or desire to acquire any ownership interest in the Divestiture Assets, together with full details of the same.

B. Within fifteen (15) calendar days of receipt by the United States of this notice, the United States may request from Defendants, the proposed Acquirer, other third parties, or the Divestiture Trustee, if applicable, additional information concerning the proposed divestiture, the proposed Acquirer and other prospective Acquirers. Defendants and the Divestiture Trustee must furnish the additional information requested within fifteen (15) calendar days of the receipt of the request, unless the United States provides written agreement to a different period.

C. Within forty-five (45) calendar days after receipt of the notice or within twenty (20) calendar days after the United States has been provided the additional information requested from Defendants, the proposed Acquirer, other third parties, and the Divestiture Trustee, whichever is later, the United States must provide written notice to Defendants and the Divestiture Trustee,

if there is one, stating whether or not the United States, in its sole discretion, objects to the proposed Acquirer or any other aspect of the proposed divestiture. If the United States provides written notice that it does not object, the divestiture may be consummated, subject only to Defendants' limited right to object to the sale under Paragraph V(C) of this Final Judgment. Absent written notice that the United States does not object or upon objection by the United States, a divestiture may not be consummated. Upon objection by Defendants pursuant to Paragraph V(C), a divestiture by the Divestiture Trustee may not be consummated unless approved by the Court.

D. No information or documents obtained pursuant to Section VI may be divulged by the United States to any person other than an authorized representative of the executive branch of the United States, except in the course of legal proceedings to which the United States is a party (including grand-jury proceedings), for the purpose of evaluating a proposed Acquirer or securing compliance with this Final Judgment, or as otherwise required by law.

E. In the event of a request by a third party for disclosure of information under the Freedom of Information Act, 5 U.S.C. 552, the Antitrust Division will act in accordance with that statute, and the Department of Justice regulations at 28 CFR part 16, including the provision on confidential commercial information, at 28 CFR 16.7. Persons submitting information to the Antitrust Division should designate the confidential commercial information portions of all applicable documents and information under 28 CFR 16.7. Designations of confidentiality expire ten years after submission, "unless the submitter requests and provides justification for a longer designation period." See 28 CFR 16.7(b).

F. If at the time a person furnishes information or documents to the United States pursuant to Section VI, that person represents and identifies in writing information or documents for which a claim of protection may be asserted under Rule 26(c)(1)(G) of the Federal Rules of Civil Procedure, and marks each pertinent page of such material, "Subject to claim of protection under Rule 26(c)(1)(G) of the Federal Rules of Civil Procedure," the United States must give that person ten calendar days' notice before divulging the material in any legal proceeding (other than a grand-jury proceeding).



## VII. Financing

Defendants may not finance all or any part of Acquirer's purchase of all or part of the Divestiture Assets made pursuant to this Final Judgment.

## VIII. Hold Separate

Until the divestiture required by this Final Judgment has been accomplished, Defendants must take all steps necessary to comply with the Hold Separate Stipulation and Order entered by the Court. Defendants will take no action that would jeopardize the divestiture ordered by the Court.

## IX. Affidavits

A. Within twenty (20) calendar days of the filing of the Complaint in this matter, and every thirty (30) calendar days thereafter until the divestiture required by this Final Judgment has been completed, Defendants must deliver to the United States an affidavit describing the fact and manner of Defendants' compliance with this Final Judgment. Odyssey's affidavits must be signed by the Vice Chairman and a Managing Principal of Odyssey Investment Partners; CPI's affidavits must be signed by its Chief Financial Officer and its highest-ranking officer; and General Dynamics's affidavits must be signed by General Dynamics Mission Systems' President and General Counsel. The United States, in its sole discretion, may approve different signatories for each affidavit. Each affidavit must include the name, address, and telephone number of each person who, during the preceding thirty (30) calendar days, made an offer to acquire, expressed an interest in acquiring, entered into negotiations to acquire, or was contacted or made an inquiry about acquiring, an interest in the Divestiture Assets, and must describe in detail each contact with such persons during that period. Each affidavit also must include a description of the efforts Defendants have taken to solicit buyers for and complete the sale of the Divestiture Assets, and to provide required information to prospective Acquirers. Each affidavit also must include a description of any limitations placed by Defendants on information provided to prospective Acquirers. If the information set forth in the affidavit is true and complete, objection by the United States to information provided by Defendants to prospective Acquirers must be made within fourteen (14) calendar days of receipt of the affidavit.

B. Within twenty (20) calendar days of the filing of the Complaint in this matter, Defendants must deliver to the United States an affidavit that describes

in reasonable detail all actions Defendants have taken and all steps Defendants have implemented on an ongoing basis to comply with Section VIII of this Final Judgment. Defendants must deliver to the United States an affidavit describing any changes to the efforts and actions outlined in Defendants' earlier affidavits filed pursuant to Section IX within fifteen (15) calendar days after the change is implemented.

C. CPI must keep all records of all efforts made to preserve and divest the Divestiture Assets until one year after the divestiture has been completed.

## X. Compliance Inspection

A. For the purposes of determining or securing compliance with this Final Judgment, or of related orders such as a Hold Separate Stipulation and Order or of determining whether this Final Judgment should be modified or vacated, and subject to any legally-recognized privilege, from time to time authorized representatives of the United States, including agents retained by the United States, must, upon written request of an authorized representative of the Assistant Attorney General in charge of the Antitrust Division, and reasonable notice to Defendants, be permitted:

(1) Access during Defendants' office hours to inspect and copy, or at the option of the United States, to require Defendants to provide electronic copies of all books, ledgers, accounts, records, data, and documents in the possession, custody, or control of Defendants, relating to any matters contained in this Final Judgment; and

(2) to interview, either informally or on the record, Defendants' officers, employees, or agents, who may have their individual counsel present, regarding such matters. The interviews must be subject to the reasonable convenience of the interviewee and without restraint or interference by Defendants.

B. Upon the written request of an authorized representative of the Assistant Attorney General in charge of the Antitrust Division, Defendants must submit written reports or respond to written interrogatories, under oath if requested, relating to any of the matters contained in this Final Judgment.

C. No information or documents obtained pursuant to Section X may be divulged by the United States to any person other than an authorized representative of the executive branch of the United States, except in the course of legal proceedings to which the United States is a party (including grand jury proceedings), for the purpose of securing compliance with this Final Judgment, or as otherwise required by law.

D. In the event of a request by a third party for disclosure of information under the Freedom of Information Act, 5 U.S.C. 552, the Antitrust Division will act in accordance with that statute, and the Department of Justice regulations at 28 CFR part 16, including the provision on confidential commercial information, at 28 CFR 16.7. Defendants submitting information to the Antitrust Division should designate the confidential commercial information portions of all applicable documents and information under 28 CFR 16.7. Designations of confidentiality expire ten years after submission, "unless the submitter requests and provides justification for a longer designation period." See 28 CFR 16.7(b).

E. If at the time that Defendants furnish information or documents to the United States pursuant to Section X, Defendants represent and identify in writing information or documents for which a claim of protection may be asserted under Rule 26(c)(1)(G) of the Federal Rules of Civil Procedure, and Defendants mark each pertinent page of such material, "Subject to claim of protection under Rule 26(c)(1)(G) of the Federal Rules of Civil Procedure," the United States must give Defendants ten (10) calendar days' notice before divulging the material in any legal proceeding (other than a grand jury proceeding).

## XI. Notification

A. Unless a transaction is otherwise subject to the reporting and waiting period requirements of the Hart-Scott-Rodino Antitrust Improvements Act of 1976, as amended, 15 U.S.C. 18a (the "HSR Act"), Odyssey and CPI, without providing advance notification to the United States, may not directly or indirectly acquire any assets of or any interest in, including a financial, security, loan, equity, or management interest, an entity involved in the design, manufacture, and sale of large ground station antennas for geostationary satellites in the United States during the term of this Final Judgment.

B. Odyssey and CPI must provide the notification required by Section XI in the same format as, and in accordance with the instructions relating to, the Notification and Report Form set forth in the Appendix to Part 803 of Title 16 of the Code of Federal Regulations as amended, except that the information requested in Items 5 through 8 of the instructions must be provided only about the design, manufacture, and sale of large ground station antennas for geostationary satellites. Notification must be provided at least thirty (30)

calendar days before acquiring any such interest, and must include, beyond the information required by the instructions, the names of the principal representatives who negotiated the agreement on behalf of each party, and all management or strategic plans discussing the proposed transaction. If, within the 30-day period following notification, representatives of the United States make a written request for additional information, Odyssey and CPI may not consummate the proposed transaction or agreement until thirty (30) calendar days after submitting all requested information. Early termination of the waiting periods in this Paragraph may be requested and, where appropriate, granted in the same manner as is applicable under the requirements and provisions of the HSR Act and rules promulgated thereunder. Section XI will be broadly construed and any ambiguity or uncertainty regarding the filing of notice under Section XI will be resolved in favor of filing notice.

C. Paragraphs XI(A) and XI(B) will only apply to Odyssey to the extent it continues to hold an interest in CPI.

#### **XII. Limitations on Reacquisition**

Odyssey and CPI may not reacquire any part of or any interest in the Divestiture Assets during the term of this Final Judgment

#### **XIII. Retention of Jurisdiction**

The Court retains jurisdiction to enable any party to this Final Judgment to apply to the Court at any time for further orders and directions as may be necessary or appropriate to carry out or construe this Final Judgment, to modify any of its provisions, to enforce compliance, and to punish violations of its provisions.

#### **XIV. Enforcement of Final Judgment**

A. The United States retains and reserves all rights to enforce the provisions of this Final Judgment, including the right to seek an order of contempt from the Court. Defendants agree that in a civil contempt action, a motion to show cause, or a similar action brought by the United States regarding an alleged violation of this Final Judgment, the United States may establish a violation of this Final Judgment and the appropriateness of a remedy therefor by a preponderance of the evidence, and Defendants waive any argument that a different standard of proof should apply.

B. This Final Judgment should be interpreted to give full effect to the procompetitive purposes of the antitrust laws and to restore the competition the

United States alleged was harmed by the challenged conduct. Defendants agree that they may be held in contempt of, and that the Court may enforce, any provision of this Final Judgment that, as interpreted by the Court in light of these procompetitive principles and applying ordinary tools of interpretation, is stated specifically and in reasonable detail, whether or not it is clear and unambiguous on its face. In any such interpretation, the terms of this Final Judgment should not be construed against either party as the drafter.

C. In an enforcement proceeding in which the Court finds that Defendants have violated this Final Judgment, the United States may apply to the Court for a one-time extension of this Final Judgment, together with other relief that may be appropriate. In connection with a successful effort by the United States to enforce this Final Judgment against a Defendant, whether litigated or resolved before litigation, that Defendant agrees to reimburse the United States for the fees and expenses of its attorneys, as well as all other costs including experts' fees, incurred in connection with that enforcement effort, including in the investigation of the potential violation.

D. For a period of four (4) years following the expiration of this Final Judgment, if the United States has evidence that a Defendant violated this Final Judgment before it expired, the United States may file an action against that Defendant in this Court requesting that the Court order: (1) Defendant to comply with the terms of this Final Judgment for an additional term of at least four years following the filing of the enforcement action; (2) all appropriate contempt remedies; (3) additional relief needed to ensure the Defendant complies with the terms of this Final Judgment; and (4) fees or expenses as called for by Section XIV.

#### **XV. Expiration of Final Judgment**

Unless the Court grants an extension, this Final Judgment will expire ten (10) years from the date of its entry, except that after five (5) years from the date of its entry, this Final Judgment may be terminated upon notice by the United States to the Court and Defendants that the divestiture has been completed and the continuation of this Final Judgment no longer is necessary or in the public interest.

#### **XVI. Public Interest Determination**

Entry of this Final Judgment is in the public interest. The parties have complied with the requirements of the Antitrust Procedures and Penalties Act, 15 U.S.C. 16, including by making available to the public copies of this

Final Judgment, the Competitive Impact Statement, comments thereon, and the United States' responses to comments. Based upon the record before the Court, which includes the Competitive Impact Statement and any comments and responses to comments filed with the Court, entry of this Final Judgment is in the public interest.

Date:

[Court approval subject to procedures of Antitrust Procedures and Penalties Act, 15 U.S.C. 16]

United States District Judge

#### **UNITED STATES DISTRICT COURT FOR THE DISTRICT OF COLUMBIA**

*United States of America, Plaintiff, v. Odyssey Investment Partners Fund V, LP; Communications & Power Industries LLC, and General Dynamics Corporation, Defendants.*

Civil Action No. 20-cv-1614

Judge: Hon. Thomas F. Hogan

#### **Competitive Impact Statement**

The United States of America, under Section 2(b) of the Antitrust Procedures and Penalties Act, 15 U.S.C. 16(b)-(h) (the "APPA" or "Tunney Act"), files this Competitive Impact Statement relating to the proposed Final Judgment submitted for entry in this civil antitrust proceeding.

#### **I. Nature and Purpose of the Proceeding**

On July 22, 2019, Communications and Power Industries LLC ("CPI") agreed to acquire General Dynamics SATCOM Technologies, Inc. ("GD SATCOM") from its parent company, General Dynamics Corporation ("General Dynamics"), for approximately \$175 million. The United States filed a civil antitrust Complaint on May 28, 2020 seeking to enjoin the proposed acquisition. The Complaint alleges that the likely effect of this acquisition would be to substantially lessen competition for the design, manufacture, and sale of large ground station antennas for geostationary satellites ("large geostationary satellite antennas") in violation of Section 7 of the Clayton Act, 15 U.S.C. 18.

At the same time the Complaint was filed, the United States filed a Hold Separate Stipulation and Order ("Stipulation and Order") and proposed Final Judgment, which are designed to address the anticompetitive effects of the acquisition. Under the proposed Final Judgment, which is explained more fully below, CPI is required to divest its subsidiary CPI ASC Signal Division Inc. ("ASC Signal"), which houses the entirety of CPI's business

that competes in the design, manufacture, and sale of large geostationary satellite antennas. Under the terms of the Stipulation and Order, CPI will take certain steps to ensure that ASC Signal is operated as a competitively independent, economically viable, and ongoing business concern, which will remain independent and uninfluenced by CPI or its parent company, Odyssey Investment Partners Fund V, LP (“Odyssey”), and that competition is maintained during the pendency of the required divestiture.

The United States and Defendants have stipulated that the proposed Final Judgment may be entered after compliance with the APPA. Entry of the proposed Final Judgment will terminate this action, except that the Court will retain jurisdiction to construe, modify, or enforce the provisions of the proposed Final Judgment and to punish violations thereof.

## II. Description of Events Giving Rise to the Alleged Violation

### (A) The Defendants and the Proposed Transaction

Odyssey, a private equity fund managed by Odyssey Investment Partners, is a Delaware limited partnership with its headquarters in New York, New York. Odyssey Investment Partners has raised over \$5 billion since its inception and invests in a wide array of industries, including aerospace and defense. CPI is a portfolio company of Odyssey. It is a Delaware corporation with its headquarters in Palo Alto, California. CPI is a global manufacturer of electronic components and subsystems focused primarily on communications and defense markets. CPI had sales of approximately \$500 million in 2019 and sells satellite communication antennas through its subsidiary, ASC Signal, a business it acquired in 2017.

General Dynamics is a Delaware corporation with its headquarters in Reston, Virginia. General Dynamics’s subsidiary, GD SATCOM, designs, manufactures, and sells satellite communications systems used in commercial, defense, and scientific applications and provides related products such as amplifiers and antennas. GD SATCOM earned between \$200 million and \$300 million in revenues in 2019.

Pursuant to a purchase agreement dated July 22, 2019, CPI intends to acquire GD SATCOM from General Dynamics for approximately \$175 million.

### (B) Industry Background

Satellite communications networks enable secure communications links in remote areas that lack access to the main telecommunications grid. For example, the Department of Defense (“DoD”) uses satellite communications networks to communicate with military bases in theaters of war, where access to the communications grid may be intermittent or even non-existent. Similarly, where it is too expensive to run traditional communications lines, commercial network operators provide satellite communications networks that individual users—or clusters of users in a central location—can use to access the internet, television, and voice communications services.

Both commercial and military satellite communications networks operate in the same way: Information is transmitted from a remote user through a satellite in orbit and back down through a ground station that is connected to a traditional communications grid. This process is reversed as information returns to the remote user. At both ends of the satellite communication link, there must be an antenna that can “see” the satellite(s) with which the ground stations are interfacing.

The satellite is the most critical, and expensive, element of a satellite communications network. Satellite-based design constraints, such as the power of the transmission signal (which is directly impacted by limitations on size and weight) and the orbit in which the satellite will operate, thus drive other significant design decisions for the entire satellite communications network.

The other key component of a satellite communications network is the ground station antenna, which connects the satellite to the communications grid. The ground station antenna consists of a parabolic dish, the structure on which the dish is mounted, and any motors or other equipment needed to move, or “point,” the dish at the satellite(s) in its network.

Several characteristics differentiate ground station antennas, but the two most important are the size of the antenna (which is typically measured by the diameter of its parabolic dish) and the ability of the antenna to track satellites that change their position relative to the Earth (as described below, some antennas remain pointed in the same direction while others track satellites as they cross the sky).

Antenna size is important because larger antennas can receive fainter signals (*i.e.*, signals impacted by rain,

clouds, or other atmospheric conditions) than smaller antennas. As a result, satellite networks using larger antennas are more reliable than networks using smaller antennas. Additionally, because larger antennas can receive fainter signals, the power requirements for the transmitting satellite (which must be supplied through batteries and/or solar generation) are diminished as compared to transmission to smaller antennas. Satellites for larger antennas therefore need not be as large or expensive as satellites for smaller antennas. Larger antennas thus decrease the overall cost of the satellite communications system.

The other major factor differentiating between types of ground station antennas is their ability to track satellites that change their position relative to the Earth. For example, satellites in geostationary orbit remain in a fixed position relative to the Earth’s rotation and are more than 20,000 miles above Earth. Antennas for geostationary satellites are therefore “fixed” and point in one direction. Low-earth orbit (“LEO”) and mid-earth orbit (“MEO”) satellites, by contrast, are multiple thousands of miles closer to earth and rotate the earth every 70 minutes. LEO and MEO satellites thus frequently “cross” the sky as they orbit and antennas used to communicate with them must be “full-motion” in order to track the LEO and MEO satellites as they move relative to the antennas’ positions. While full motion antennas duplicate some of the capabilities of fixed antennas, they are typically only used for LEO and MEO satellites because they are significantly more expensive due to the motors and structural design elements necessary to ensure accurate full-motion pointing. Fixed antennas are thus more cost-effective than full-motion antennas.

### (C) Relevant Markets

#### 3. Product Market

For DoD customers, satellite communications networks provide vital communications links for the battlefield and other remote locations. For many uses, DoD requires large geostationary satellite antennas in order to guarantee reliable communications connections. DoD cannot switch to smaller geostationary antennas without compromising the reliability and usefulness of its network. Because switching to smaller geostationary antennas would effectively render a satellite communications network unfit for its intended use, the Complaint alleges that DoD is unlikely to switch to smaller geostationary antennas in response to a small but significant

increase in price for large geostationary satellite antennas.

According to the Complaint, commercial customers—whose reliability requirements are not as rigid as DoD's—are also unlikely to switch to smaller geostationary antennas in the event of a small but significant increase in price for large geostationary satellite antennas because, like DoD, doing so would decrease the reliability of their network. Further, switching to smaller geostationary antennas would require a satellite communications network with a larger—and significantly more expensive—satellite at its core, thus increasing the overall cost of the network.

Similarly, the Complaint alleges that DoD and commercial customers with geostationary satellites are unlikely to switch from fixed to full-motion antennas—like those used for MEO and LEO satellites—in response to a small but significant increase in price of fixed antennas. Even when full-motion antennas have similar capabilities to fixed antennas, they are significantly more expensive due to the additional motors and equipment necessary to ensure accurate full-motion pointing.

According to the Complaint, customers will not substitute to smaller or full-motion antennas in response to a small but significant and non-transitory increase in the price of large geostationary satellite antennas. Therefore, the Complaint alleges that the design, manufacture, and sale of large geostationary satellite antennas is a relevant product market and line of commerce under Section 7 of the Clayton Act, 15 U.S.C. 18.

#### 4. Geographic Market

The Complaint alleges that the relevant geographic market for large geostationary satellite antennas is the United States. For national security reasons, DoD prefers domestic suppliers of large geostationary satellite antennas when it is deciding on potential antenna sources. Similarly, commercial customers prefer domestic suppliers of large geostationary satellite antennas, in part because they resell network access to DoD and other government customers that prefer to avoid having foreign suppliers for components in the transmission chain for sensitive national security-related information. For these reasons, neither DoD nor commercial customers are likely to turn to any foreign suppliers in the face of a small but significant and non-transitory price increase by domestic suppliers of large geostationary satellite antennas.

#### *(D) Anticompetitive Effects of the Proposed Transaction*

As alleged in the Complaint, CPI, through its subsidiary ASC Signal, and GD SATCOM are the only two significant suppliers that design, manufacture, and sell large geostationary satellite antennas in the United States. The merger would give the combined firm an effective monopoly, leaving customers, including DoD, without a meaningful competitive alternative for this critical component of satellite communications networks.

According to the Complaint, CPI and GD SATCOM compete for sales of large geostationary satellite antennas on the basis of quality, price, and contractual terms such as delivery times. This competition has resulted in higher quality, lower prices, and shorter delivery times. The combination of CPI and GD SATCOM would eliminate this competition and its future benefits to customers, including DoD. Post-acquisition, the merged firm likely would have the incentive and ability to increase prices and offer less favorable contractual terms.

As described in the Complaint, competition between CPI and GD SATCOM has also fostered important industry innovation, leading to antennas that are more durable, can withstand more extreme environments, and operate at higher bandwidths. The combination of CPI and GD SATCOM would eliminate this competition and its future benefits to customers, including DoD. Post-acquisition, the merged firm likely would have less incentive to engage in research and development efforts that lead to innovative and high-quality products.

#### *(E) Entry*

According to the Complaint, entry of additional competitors into the market for the design, manufacture, and sale of large geostationary satellite antennas in the United States is unlikely to prevent the harm to competition that is likely to result if the proposed acquisition is consummated. Production facilities for large geostationary satellite antennas require a substantial investment in both capital equipment and human resources. A new entrant would need to set up a factory to produce parabolic dishes, design the complex electronic assemblies and components necessary to point the antenna, and build assembly lines and testing facilities. Engineering and research personnel would need to be assigned to design, test, and troubleshoot the complex manufacturing process that is necessary to produce large geostationary satellite

antennas. Any new products manufactured by such an entrant would also require extensive testing and qualification before they could be used by the U.S. military. As a result, the Complaint alleges that entry would be costly and time-consuming.

#### **III. Explanation of the Proposed Final Judgment**

The divestiture required by the proposed Final Judgment will remedy the loss of competition alleged in the Complaint by establishing an independent and economically viable competitor in the design, manufacture, and sale of large geostationary satellite antennas. Paragraph IV(A) of the proposed Final Judgment requires CPI, within the later of 60 calendar days after the entry of the Stipulation and Order by the Court or 30 calendar days after all regulatory approvals needed to complete the transaction and divestiture have been received, to divest the Divestiture Assets. The assets must be divested in such a way as to satisfy the United States in its sole discretion that they can and will be operated by the purchaser as a viable, ongoing business that can compete effectively in the design, manufacture, and sale of large geostationary satellite antennas. The regulatory approvals are defined in Paragraph II(J) of the proposed Final Judgment and include approvals or clearances pursuant to filings with the Committee on Foreign Investment in the United States (“CFIUS”) or under antitrust or competition laws required for CPI's acquisition of GD SATCOM and approvals or clearances pursuant to filings with CFIUS or under antitrust, competition, or other U.S. or international laws or regulations required for the divestiture of the Divestiture Assets. The Divestiture Assets are defined as ASC Signal, and include four facilities (a support facility in Plano, Texas, a manufacturing facility located in Whitby, Ontario, and testing facilities located in Ashburn, Ontario and Caddo Mills, Texas) and all tangible and intangible assets related to or used in connection with the ASC Signal. CPI must take all reasonable steps necessary to accomplish the divestiture quickly and must cooperate with prospective purchasers.

The proposed Final Judgment also contains provisions intended to facilitate the acquirer's efforts to hire employees supporting ASC Signal. Paragraph IV(C) of the proposed Final Judgment requires CPI to provide the acquirer and the United States with organization charts and information relating to these employees and to make them available for interviews, and it

provides that the Defendants must not interfere with any negotiations by the acquirer to hire them. In addition, for employees who elect employment with the acquirer, CPI must waive all non-compete and non-disclosure agreements, vest all unvested pension and other equity rights, and provide all benefits that the employees would generally be provided if transferred to a buyer of an ongoing business. This paragraph further provides that the Defendants may not solicit to hire any employee of the Divestiture Assets who was hired by the acquirer, unless that individual is terminated or laid off by the acquirer or the acquirer agrees in writing that the Defendants may solicit to hire that individual. The non-solicitation period runs for 12 months from the date of the divestiture.

Paragraph IV(H) of the proposed Final Judgment requires CPI, at the acquirer's option, to enter into a transition services agreement for back office, human resource, and information technology services and support for ASC Signal for a period of up to 12 months. The paragraph further provides that the United States, in its sole discretion, may approve one or more extensions of this transition services agreement for a total of up to an additional six months. Paragraph IV(H) also provides that employees of CPI tasked with providing any transition services must not share any competitively sensitive information of the acquirer with any other employee of Defendants.

Paragraph IV(G) of the proposed Final Judgment facilitates the transfer of customers and other contractual relationships from CPI to the acquirer. CPI must transfer all contracts, agreements, and relationships to the acquirer and must make best efforts to assign, subcontract, or otherwise transfer contracts or agreements that require the consent of another party before assignment, subcontracting or other transfer.

If CPI does not accomplish the divestiture within the period prescribed in the proposed Final Judgment, Section V of the proposed Final Judgment provides that the Court will appoint a divestiture trustee selected by the United States to effect the divestiture. If a divestiture trustee is appointed, the proposed Final Judgment provides that CPI will pay all costs and expenses of the trustee. The divestiture trustee's commission will be structured so as to provide an incentive for the trustee based on the price obtained and the speed with which the divestiture is accomplished. After the divestiture trustee's appointment becomes effective, the trustee will provide periodic reports

to the United States setting forth his or her efforts to accomplish the divestiture. At the end of six months, if the divestiture has not been accomplished, the divestiture trustee and the United States will make recommendations to the Court, which will enter such orders as appropriate, in order to carry out the purpose of the trust, including by extending the trust or the term of the divestiture trustee's appointment.

Section XI of the proposed Final Judgment requires Odyssey and CPI to notify the United States in advance of acquiring an entity involved in the design, manufacture, and sale of large ground station antennas for geostationary satellites in the United States in a transaction that would not otherwise be reportable under the Hart-Scott-Rodino Antitrust Improvements Act of 1976, as amended, 15 U.S.C. 18a (the "HSR Act"). The proposed Final Judgment further provides for waiting periods and opportunities for the United States to obtain additional information analogous to the provisions of the HSR Act. Because CPI and GD Satcom are the only two significant suppliers of these products in the United States, it is important for the Division to receive notice of even small transactions that have the potential to eliminate competition in this market through the acquisition of an important startup or new entrant. Requiring notification of any acquisition of an entity involved in the design, manufacture, and sale of large ground station antennas for geostationary satellites in the United States will permit the United States to assess the competitive effects of that acquisition before it is consummated and, if necessary, seek to enjoin the transaction.

The proposed Final Judgment also contains provisions designed to promote compliance and make the enforcement of the Final Judgment as effective as possible. Paragraph XIV(A) provides that the United States retains and reserves all rights to enforce the provisions of the Final Judgment, including its rights to seek an order of contempt from the Court. Under the terms of this paragraph, Defendants have agreed that in any civil contempt action, any motion to show cause, or any similar action brought by the United States regarding an alleged violation of the Final Judgment, the United States may establish the violation and the appropriateness of any remedy by a preponderance of the evidence and that Defendants have waived any argument that a different standard of proof should apply. This provision aligns the standard for compliance obligations with the standard of proof that applies

to the underlying offense that the compliance commitments address.

Paragraph XIV(B) provides additional clarification regarding the interpretation of the provisions of the proposed Final Judgment. The proposed Final Judgment is intended to restore competition the United States alleges would otherwise be harmed by the transaction. Defendants agree that they will abide by the proposed Final Judgment, and that they may be held in contempt of this Court for failing to comply with any provision of the proposed Final Judgment that is stated specifically and in reasonable detail, as interpreted in light of this procompetitive purpose.

Paragraph XIV(C) of the proposed Final Judgment provides that if the Court finds in an enforcement proceeding that Defendants have violated the Final Judgment, the United States may apply to the Court for a one-time extension of the Final Judgment, together with such other relief as may be appropriate. In addition, to compensate American taxpayers for any costs associated with investigating and enforcing violations of the Final Judgment, Paragraph XIV(C) provides that in any successful effort by the United States to enforce the Final Judgment against a Defendant, whether litigated or resolved before litigation, that Defendant will reimburse the United States for attorneys' fees, experts' fees, and other costs incurred in connection with any enforcement effort, including the investigation of the potential violation.

Paragraph XIV(D) states that the United States may file an action against a Defendant for violating the Final Judgment for up to four years after the Final Judgment has expired or been terminated. This provision is meant to address circumstances such as when evidence that a violation of the Final Judgment occurred during the term of the Final Judgment is not discovered until after the Final Judgment has expired or been terminated or when there is not sufficient time for the United States to complete an investigation of an alleged violation until after the Final Judgment has expired or been terminated. This provision, therefore, makes clear that, for four years after the Final Judgment has expired or been terminated, the United States may still challenge a violation that occurred during the term of the Final Judgment.

Finally, Section XV of the proposed Final Judgment provides that the Final Judgment will expire ten years from the date of its entry, except that after five years from the date of its entry, the Final Judgment may be terminated upon

notice by the United States to the Court and Defendants that the divestiture has been completed and that the continuation of the Final Judgment is no longer necessary or in the public interest.

#### IV. Remedies Available to Potential Private Litigants

Section 4 of the Clayton Act, 15 U.S.C. 15, provides that any person who has been injured as a result of conduct prohibited by the antitrust laws may bring suit in federal court to recover three times the damages the person has suffered, as well as costs and reasonable attorneys' fees. Entry of the proposed Final Judgment neither impairs nor assists the bringing of any private antitrust damage action. Under the provisions of Section 5(a) of the Clayton Act, 15 U.S.C. 16(a), the proposed Final Judgment has no prima facie effect in any subsequent private lawsuit that may be brought against Defendants.

#### V. Procedures Available for Modification of the Proposed Final Judgment

The United States and Defendants have stipulated that the proposed Final Judgment may be entered by the Court after compliance with the provisions of the APPA, provided that the United States has not withdrawn its consent. The APPA conditions entry upon the Court's determination that the proposed Final Judgment is in the public interest.

The APPA provides a period of at least 60 days preceding the effective date of the proposed Final Judgment within which any person may submit to the United States written comments regarding the proposed Final Judgment. Any person who wishes to comment should do so within 60 days of the date of publication of this Competitive Impact Statement in the **Federal Register**, or the last date of publication in a newspaper of the summary of this Competitive Impact Statement, whichever is later. All comments received during this period will be considered by the U.S. Department of Justice, which remains free to withdraw its consent to the proposed Final Judgment at any time before the Court's entry of the Final Judgment. The comments and the response of the United States will be filed with the Court. In addition, comments will be posted on the U.S. Department of Justice, Antitrust Division's internet website and, under certain circumstances, published in the **Federal Register**.

Written comments should be submitted to: Katrina Rouse, Chief, Defense, Industrials, and Aerospace

Section, Antitrust Division, U.S. Department of Justice, 450 Fifth Street, NW, Suite 8700, Washington, DC 20530.

The proposed Final Judgment provides that the Court retains jurisdiction over this action, and the parties may apply to the Court for any order necessary or appropriate for the modification, interpretation, or enforcement of the Final Judgment.

#### VI. Alternatives to the Proposed Final Judgment

As an alternative to the proposed Final Judgment, the United States considered a full trial on the merits against Defendants. The United States could have continued the litigation and sought preliminary and permanent injunctions against CPI's acquisition of GD SATCOM. The United States is satisfied, however, that the divestiture of assets described in the proposed Final Judgment will remedy the anticompetitive effects alleged in the Complaint, preserving competition for the design, manufacture, and sale of large geostationary satellite antennas. Thus, the proposed Final Judgment achieves all or substantially all of the relief the United States would have obtained through litigation, but avoids the time, expense, and uncertainty of a full trial on the merits of the Complaint.

#### VII. Standard of Review Under the APPA for the Proposed Final Judgment

The Clayton Act, as amended by the APPA, requires that proposed consent judgments in antitrust cases brought by the United States be subject to a 60-day comment period, after which the Court shall determine whether entry of the proposed Final Judgment "is in the public interest." 15 U.S.C. 16(e)(1). In making that determination, the Court, in accordance with the statute as amended in 2004, is required to consider:

(A) The competitive impact of such judgment, including termination of alleged violations, provisions for enforcement and modification, duration of relief sought, anticipated effects of alternative remedies actually considered, whether its terms are ambiguous, and any other competitive considerations bearing upon the adequacy of such judgment that the court deems necessary to a determination of whether the consent judgment is in the public interest; and

(B) the impact of entry of such judgment upon competition in the relevant market or markets, upon the public generally and individuals alleging specific injury from the violations set forth in the complaint including consideration of the public benefit, if any, to be derived from a determination of the issues at trial.

15 U.S.C. 16(e)(1)(A) & (B). In considering these statutory factors, the

Court's inquiry is necessarily a limited one as the government is entitled to "broad discretion to settle with the defendant within the reaches of the public interest." *United States v. Microsoft Corp.*, 56 F.3d 1448, 1461 (D.C. Cir. 1995); *United States v. U.S. Airways Grp., Inc.*, 38 F. Supp. 3d 69, 75 (D.D.C. 2014) (explaining that the "court's inquiry is limited" in Tunney Act settlements); *United States v. InBev N.V./S.A.*, No. 08-1965 (JR), 2009 U.S. Dist. LEXIS 84787, at \*3 (D.D.C. Aug. 11, 2009) (noting that a court's review of a consent judgment is limited and only inquires "into whether the government's determination that the proposed remedies will cure the antitrust violations alleged in the complaint was reasonable, and whether the mechanism to enforce the final judgment are clear and manageable").

As the U.S. Court of Appeals for the District of Columbia Circuit has held, under the APPA a court considers, among other things, the relationship between the remedy secured and the specific allegations in the government's complaint, whether the proposed Final Judgment is sufficiently clear, whether its enforcement mechanisms are sufficient, and whether it may positively harm third parties. *See Microsoft*, 56 F.3d at 1458-62. With respect to the adequacy of the relief secured by the proposed Final Judgment, a court may not "make de novo determination of facts and issues." *United States v. W. Elec. Co.*, 993 F.2d 1572, 1577 (D.C. Cir. 1993) (quotation marks omitted); *see also Microsoft*, 56 F.3d at 1460-62; *United States v. Alcoa, Inc.*, 152 F. Supp. 2d 37, 40 (D.D.C. 2001); *United States v. Enova Corp.*, 107 F. Supp. 2d 10, 16 (D.D.C. 2000); *InBev*, 2009 U.S. Dist. LEXIS 84787, at \*3. Instead, "[t]he balancing of competing social and political interests affected by a proposed antitrust consent decree must be left, in the first instance, to the discretion of the Attorney General." *W. Elec. Co.*, 993 F.2d at 1577 (quotation marks omitted). "The court should bear in mind the *flexibility* of the public interest inquiry: the court's function is not to determine whether the resulting array of rights and liabilities is one that will *best* serve society, but only to confirm that the resulting settlement is within the *reaches* of the public interest." *Microsoft*, 56 F.3d at 1460 (quotation marks omitted); *see also United States v. Deutsche Telekom AG*, No. 19-2232 (TJK), 2020 WL 1873555, at \*7 (D.D.C. Apr. 14, 2020). More demanding requirements would "have enormous practical consequences for the government's ability to negotiate future

settlements,” contrary to congressional intent. *Id.* at 1456. “The Tunney Act was not intended to create a disincentive to the use of the consent decree.” *Id.*

The United States’ predictions about the efficacy of the remedy are to be afforded deference by the Court. *See, e.g., Microsoft*, 56 F.3d at 1461 (recognizing courts should give “due respect to the Justice Department’s . . . view of the nature of its case”); *United States v. Iron Mountain, Inc.*, 217 F. Supp. 3d 146, 152–53 (D.D.C. 2016) (“In evaluating objections to settlement agreements under the Tunney Act, a court must be mindful that [t]he government need not prove that the settlements will perfectly remedy the alleged antitrust harms[;] it need only provide a factual basis for concluding that the settlements are reasonably adequate remedies for the alleged harms.”) (internal citations omitted); *United States v. Republic Servs., Inc.*, 723 F. Supp. 2d 157, 160 (D.D.C. 2010) (noting “the deferential review to which the government’s proposed remedy is accorded”); *United States v. Archer-Daniels-Midland Co.*, 272 F. Supp. 2d 1, 6 (D.D.C. 2003) (“A district court must accord due respect to the government’s prediction as to the effect of proposed remedies, its perception of the market structure, and its view of the nature of the case.”). The ultimate question is whether “the remedies [obtained by the Final Judgment are] so inconsonant with the allegations charged as to fall outside of the ‘reaches of the public interest.’” *Microsoft*, 56 F.3d at 1461 (quoting *W. Elec. Co.*, 900 F.2d at 309).

Moreover, the Court’s role under the APPA is limited to reviewing the remedy in relationship to the violations that the United States has alleged in its complaint, and does not authorize the Court to “construct [its] own hypothetical case and then evaluate the decree against that case.” *Microsoft*, 56 F.3d at 1459; *see also U.S. Airways*, 38 F. Supp. 3d at 75 (noting that the court must simply determine whether there is a factual foundation for the government’s decisions such that its conclusions regarding the proposed settlements are reasonable); *InBev*, 2009 U.S. Dist. LEXIS 84787, at \*20 (“[T]he ‘public interest’ is not to be measured by comparing the violations alleged in the complaint against those the court believes could have, or even should have, been alleged”). Because the “court’s authority to review the decree depends entirely on the government’s exercising its prosecutorial discretion by bringing a case in the first place,” it follows that “the court is only authorized to review the decree itself,”

and not to “effectively redraft the complaint” to inquire into other matters that the United States did not pursue. *Microsoft*, 56 F.3d at 1459–60.

In its 2004 amendments to the APPA, Congress made clear its intent to preserve the practical benefits of using consent judgments proposed by the United States in antitrust enforcement, Public Law 108–237 § 221, and added the unambiguous instruction that “[n]othing in this section shall be construed to require the court to conduct an evidentiary hearing or to require the court to permit anyone to intervene.” 15 U.S.C. 16(e)(2); *see also U.S. Airways*, 38 F. Supp. 3d at 76 (indicating that a court is not required to hold an evidentiary hearing or to permit intervenors as part of its review under the Tunney Act). This language explicitly wrote into the statute what Congress intended when it first enacted the Tunney Act in 1974. As Senator Tunney explained: “[t]he court is nowhere compelled to go to trial or to engage in extended proceedings which might have the effect of vitiating the benefits of prompt and less costly settlement through the consent decree process.” 119 Cong. Rec. 24,598 (1973) (statement of Sen. Tunney). “A court can make its public interest determination based on the competitive impact statement and response to public comments alone.” *U.S. Airways*, 38 F. Supp. 3d at 76 (citing *Enova Corp.*, 107 F. Supp. 2d at 17).

#### VIII. Determinative Documents

There are no determinative materials or documents within the meaning of the APPA that were considered by the United States in formulating the proposed Final Judgment.

Dated: May 28, 2020

Respectfully submitted,

Jay D. Owen,  
Assistant Chief,  
Defense, Industrials, and Aerospace Section,  
Antitrust Division, U.S. Department of  
Justice, 450 Fifth St. NW, Suite 8700,  
Washington, DC 205, Telephone (202) 598–  
2987, Facsimile (202) 514–9033, jay.owen@  
usdoj.gov.

[FR Doc. 2020–12289 Filed 6–5–20; 8:45 am]

BILLING CODE 4410–11–P

## DEPARTMENT OF JUSTICE

### Antitrust Division

#### Notice Pursuant to the National Cooperative Research and Production Act of 1993—Petroleum Environmental Research Forum

Notice is hereby given that, on May 13, 2020, pursuant to Section 6(a) of the National Cooperative Research and Production Act of 1993, 15 U.S.C. 4301 *et seq.* (“the Act”), Petroleum Environmental Research Forum (“PERF”) has filed written notifications simultaneously the Attorney General and the Federal Trade Commission disclosing changes in its membership. The notifications were filed for the purpose of extending the Act’s provisions limiting the recovery of antitrust plaintiffs to actual damages under specified circumstances. Specifically, Suncor Energy Inc. and Tullow Oil Plc have withdrawn as parties to this venture.

No other changes have been made in either the membership or planned activity of the group research project. Membership in this group research project remains open, and PERF intends to file additional written notifications disclosing all changes in membership.

On February 10, 1986, PERF filed its original notification pursuant to Section 6(a) of the Act. The Department of Justice published a notice in the **Federal Register** pursuant to Section 6(b) of the Act on March 14, 1986 (51 FR 8903).

The last notification was filed with the Department on February 22, 2019. A notice was published in the **Federal Register** pursuant to Section 6(h) of the Act on March 08, 2019 (84 FR 8545).

Suzanne Morris,

Chief, Premerger and Division Statistics,  
Antitrust Division.

[FR Doc. 2020–12305 Filed 6–5–20; 8:45 am]

BILLING CODE 4410–11–P

## DEPARTMENT OF JUSTICE

### Antitrust Division

#### Notice Pursuant to the National Cooperative Research and Production Act of 1993—Automotive Cybersecurity Industry Consortium

Notice is hereby given that, on May 29, 2020, pursuant to Section 6(a) of the National Cooperative Research and Production Act of 1993, 15 U.S.C. 4301 *et seq.* (“the Act”), Automotive Cybersecurity Industry Consortium (“ACIC”) has filed written notifications simultaneously with the Attorney General and the Federal Trade