

**DEPARTMENT OF TRANSPORTATION****Federal Railroad Administration****49 CFR Part 299**

[Docket No. FRA–2019–0068, Notice 1]

RIN 2130–AC84

**Texas Central Railroad High-Speed Rail Safety Standards**

**AGENCY:** Federal Railroad Administration (FRA), Department of Transportation (DOT).

**ACTION:** Notice of proposed rulemaking; rule of particular applicability.

**SUMMARY:** FRA is proposing a rule of particular applicability (RPA) to establish safety standards for the Texas Central Railroad (TCRR or the railroad) high speed rail system. The proposed standards are not intended for general application in the railroad industry, but would apply only to the TCRR system planned for development in the State of Texas. The proposed RPA takes a systems approach to safety, and so includes standards that address all aspects of the TCRR high-speed system, including signal and trainset control, track, rolling stock, operating practices, system qualifications, and maintenance. The TCRR system is planned to operate from Houston to Dallas, on dedicated track, with no grade crossings, at speeds not to exceed 330 km/h (205 mph). The TCRR rolling stock, track, and core systems will replicate the Central Japan Railway Company (JRC), Tokaido Shinkansen high-speed rail system, and will be used exclusively for revenue passenger service.

**DATES:** Written comments must be received by May 11, 2020. Comments received after that date will be considered to the extent possible without incurring additional expense or delay.

FRA anticipates holding three public hearings to receive oral comment on this NPRM, and that proceedings will also be necessary under 49 U.S.C. 20306. FRA will publish a separate announcement in the **Federal Register** to inform interested parties of the date, time, and location of these hearings.

**ADDRESSES:** *Comments:* Comments related to Docket No. FRA–2019–0068, Notice No. 1, may be submitted by any of the following methods:

- *Federal eRulemaking Portal:* Go to <http://www.regulations.gov> and follow the online instructions for submitting comments;
- *Fax:* 202–493–2251;
- *Mail:* Docket Management Facility, U.S. Department of Transportation, 1200

New Jersey Avenue SE, Room W12–140, Washington, DC 20590; or

- *Hand Delivery:* Docket Management Facility, U.S. Department of Transportation, 1200 New Jersey Avenue SE, Room W12–140 is located on the ground level of the West Building, between 9 a.m. and 5 p.m., Monday through Friday, except Federal holidays.

*Instructions:* All submissions must include the agency name and docket number or Regulatory Identification Number (RIN) for this rulemaking (2130–AC84). Note that all comments received will be posted without change to <http://www.regulations.gov>, including any personal information provided. Please see the Privacy Act heading in the **SUPPLEMENTARY INFORMATION** section of this document for Privacy Act information related to any submitted comments or materials.

*Docket:* For access to the docket to read background documents or comments received, go to <http://www.regulations.gov> at any time or visit the Docket Management Facility, U.S. Department of Transportation, 1200 New Jersey Avenue SE, Room W12–140 on the Ground level of the West Building, between 9 a.m. and 5 p.m., Monday through Friday, except Federal holidays.

**FOR FURTHER INFORMATION CONTACT:** Frederick Mottley, Systems Engineer, U.S. Department of Transportation, Federal Railroad Administration, Office of Railroad Safety, 1200 New Jersey Avenue SE, Washington, DC 20590 (telephone: (617) 494–3160); or Michael Hunter, Attorney Adviser, U.S. Department of Transportation, Federal Railroad Administration, Office of Chief Counsel, 1200 New Jersey Avenue SE, Washington, DC 20590 (telephone: (202) 493–0368).

**SUPPLEMENTARY INFORMATION:****Table of Contents**

- I. Executive Summary
- II. Statutory Authority
- III. Regulatory Approach
- IV. Project Background and Regulatory Development
  - A. History of Tokaido Shinkansen
  - B. RPA Development Process
  - C. The Proposed System
    1. Rolling Stock
    2. Automatic Train Control System
    3. Track Safety Standards
    4. Maintenance-of-Way Operations
    5. System Qualification
    6. Personnel Qualification
    7. Inspection, Testing, and Maintenance
    8. Operating Rules and Practices
  - D. Applicability of FRA's Current Regulations
  - E. Incorporation by Reference
  - F. Enforcement

## V. Regulatory Impact and Notices

- A. Executive Orders 12866 and 13771, and DOT Regulatory Policies and Procedures
- B. Regulatory Flexibility Act and Executive Order 13272; Regulatory Flexibility Assessment
- C. Paperwork Reduction Act
- D. Federalism Implications
- E. International Trade Impact Assessment
- F. Environmental Impact
- G. Executive Order 12898 (Environmental Justice)
- H. Executive Order 13175 (Tribal Consultation)
- I. Unfunded Mandates Reform Act of 1995
- J. Energy Impact
- K. Privacy Act Statement

**I. Executive Summary**

On August 30, 2019, FRA granted TCRR's petition for rulemaking (petition), which was submitted April 15, 2016. TCRR's petition represented that the regulatory requirements offered by TCRR translate the technological and operational aspects of the JRC Tokaido Shinkansen system.

The Tokaido Shinkansen first went into service on October 1, 1964, under the operation of the Japanese National Railways (JNR). On April 1, 1987, JNR was privatized and split into six passenger railroads and a freight railroad. JRC was the company that took over operations of the Tokaido Shinkansen system, and is still operating the system today. In 50+ years of Tokaido Shinkansen system operations, JNR, and now JRC, have optimized its operations to a very high level of performance. Accordingly, the Shinkansen has moved over 6 billion passengers without a passenger fatality or injury due to trainset accidents such as a derailment or collision.

TCRR intends to implement a high-speed passenger rail system, based upon the service-proven technology used on the Tokaido Shinkansen and replicating the operational and maintenance practices and procedures employed by JRC. TCRR plans to implement the latest, service-proven derivative of the N700 trainset and other core systems currently in use on the Tokaido Shinkansen line,<sup>1</sup> which have been refined for high-speed operations over the last 50+ years. TCRR plans to adapt the N700 series trainset and supporting systems in a manner that is appropriate for the Texas environment and operate under a regulatory framework that enables FRA to provide effective safety oversight.

Additionally, FRA has prepared an analysis of the economic impact of this

<sup>1</sup> Subsequent references to "N700" or "N700 series trainset" are meant to refer to the N700 series trainset currently in, or future variants approved for, use.

proposed rule under section V.A., below. FRA concluded that because the NPRM generally includes only voluntary actions, or alternative action that would be voluntary, the NPRM does not impart additional burdens on TCRR.

## II. Statutory Authority

Under the Federal railroad safety laws, FRA has jurisdiction over all railroads, as defined in 49 U.S.C. 20102, except urban rapid transit operations that are not connected to the general railroad system of transportation. Moreover, FRA would consider a stand-alone intercity railroad line to be part of the general system, even though not physically connected to other railroads (as FRA has previously stated with respect to the Alaska Railroad; *see* 49 CFR part 209, appendix A). FRA considers the contemplated TCRR system as intercity passenger rail, not urban rapid transit. Accordingly, the TCRR system will be subject to FRA jurisdiction whether it is connected to the general railroad system or not. Please see FRA's policy statement discussing in greater detail FRA's jurisdiction over passenger railroads, which includes discussion on how FRA's characterizes passenger operations, contained at 49 CFR part 209, appendix A.

FRA has a regulatory program in place, pursuant to its statutory authority, to address equipment, track, operating practices, and human factors in the existing, conventional railroad environment. However, significant operational and equipment differences exist between the system proposed for Texas and existing passenger operations in the United States. In many of the railroad safety disciplines, FRA's existing regulations do not address the safety concerns and operational peculiarities of the proposed TCRR system. Therefore, in order to allow TCRR to operate with effective safety oversight, an alternative regulatory approach is required.

## III. Regulatory Approach

Consistent with its statement in the most recent Passenger Equipment Safety Standards final rule, published November 21, 2018 (83 FR 59182), FRA proposes to regulate the TCRR system as a stand-alone system under this enabling rule. FRA stated that a stand-alone system regulation would have to bring together all aspects of railroad safety (such as operating practices, signal and trainset control, and track) that must be applied to the individual system. *See* 83 FR 59182, 59186. Such an approach covers more than passenger equipment,

and would likely necessitate particular right-of-way intrusion protection and other safety requirements not adequately addressed in FRA's regulations. FRA continues to believe that addressing proposals for stand-alone high-speed rail systems on a case-by-case basis and comprehensively (such as through an RPA or other specific regulatory action(s)) is prudent because of the small number of potential operations, and the potential for significant and unique differences in their design. Entities considering such operations voluntarily assume the higher costs of building new infrastructure, knowing they cannot take advantage of the cost savings from sharing existing infrastructure.

Alternatively, FRA could issue a comprehensive set of waivers from FRA's existing regulations, to the extent permitted by law, under 49 U.S.C. 20103(b), in order to provide regulatory approval to the operation. However, in this case, electing to develop and publish a comprehensive regulation is a more efficient alternative. Such a regulation, in addition to providing regulatory approval, institutes a comprehensive regulatory framework, that provides TCRR clarity on the minimum Federal safety standards that it must comply with through technology-specific requirements, incorporating the service-proven aspects of the Tokaido Shinkansen system. Additionally, it provides the railroad a higher degree of regulatory certainty than would waivers, as waivers are revocable, subject to changing conditions, and necessitate renewal, generally every five years.

## IV. Project Background and Regulatory Development

TCRR plans to construct and operate a high-speed rail system running approximately 240 miles from Houston, TX, to Dallas, TX, with a stop in Grimes County east of College Station, TX. The system's trainset will travel on dedicated rail, with no public grade crossings, in exclusive passenger service, at speeds not to exceed 330 km/h (205 mph). These operational characteristics, and the equipment that TCRR plans to use, mark a significant technological advancement in regional, high-speed, passenger rail service in the United States.

The system TCRR proposes to build in Texas will replicate the service-proven Japanese Tokaido Shinkansen high-speed rail system, as operated by JRC. TCRR is modeling its system on the Tokaido Shinkansen system because of its reputation as being one of the safest and most punctual train systems in the

world over its 50-year history. TCRR seeks to model its operation on JRC's operational and maintenance practices and philosophies, and utilize the high-speed technology that was developed and refined in Japan, known as the Shinkansen N700 series (Shinkansen or N700). The Shinkansen series of high-speed trainsets has been in service in Japan since 1964 and has safely carried over 6 billion passengers with no passenger fatalities or injuries due to trainset accidents/incidents such as a derailment or collision in while in revenue train operations. The N700 series was first introduced by JRC in 2007.

This is a traditional rail system, in the sense that steel wheels operate over steel rails, powered by electrical power that is carried and transferred to the equipment through an overhead catenary system. However, the Tokaido Shinkansen system is engineered to maximize the advantage of its dedicated environment, resulting in rolling stock that is much lighter than conventional rail vehicles; track conditions that are tuned specifically to low-mass, high-speed operations; and advanced aerodynamic technology that facilitates travel at very high speeds, with minimal track and equipment degradation.

The lightweight design of the equipment permits exceptional performance and safety for high-speed travel, but also lends itself to inherent deficiencies if exposed to many of the risks presented by conventional lines, such as a train-to-train collision or a grade crossing accident, particularly where heavy freight or commercial vehicles are present. To counter this aspect of the design, the Tokaido Shinkansen system and N700 series of trainsets are operated with a focus on collision avoidance, utilizing a systems-approach to safety to mitigate or eliminate potential risks through the design of the entire system as a whole, rather than focusing on individual aspects of an operation (*e.g.*, rolling stock crashworthiness). This approach to eliminating or mitigating risks and hazards through design has an inherent safety that has proven to be incredibly successful. (It is also important to note that the Texas system will be prohibited, as proposed in this NPRM, from allowing any freight traffic on its system.) The Shinkansen is equipped with an advanced trainset control system that is optimized for the high-speed operations. The Shinkansen system has an exceedingly safe record, which is discussed in greater detail below.

### A. History of the Tokaido Shinkansen

The term “Shinkansen” is used to denote the Japanese high-speed rail system, also known as the “bullet train.” The Japan National Railway system was privatized into six passenger railways in 1986. The name “Tokaido Shinkansen” is the initial high-speed trainset system introduced in 1964. It is now owned and operated by JRC.

The Tokaido Shinkansen operates high-speed service between Tokyo and Shin-Osaka, a route that is 515 km long, at a maximum operating speed of 270 km/h (168 mph).<sup>2</sup> With 17 passenger stations on the system, the operation includes 368 daily departures. Although TCRR is replicating the Tokaido Shinkansen system, FRA notes that some of the N700 trainsets also travel over the Sanyo Shinkansen system between Shin-Osaka and Hakata, a route that is 554 km in length, which is operated by the West Japan Railway Company. The maximum operating speed is 300 km/h on the Sanyo Shinkansen.

Each 16-car trainset on the Tokaido Shinkansen is equipped with 1,323 seats. According to JRC, the annual ridership in 2017 was 170 million passengers, or 466,000 passengers per day. In over 50 years of service, the Shinkansen has moved over 6 billion passengers and traveled over 632 million rolling stock miles. The minimum headway between high-speed trainsets is 3 minutes 15 seconds during peak travel times. The average annual delay of trainsets is less than 1 minute.

### B. RPA Petition Development Process

In March 2014, TCRR sought FRA’s technical assistance in the development of a rulemaking petition. In order to assist TCRR with its effort, an RPA Working Group was established consisting of Core Team members from both TCRR and FRA. For discipline-specific discussions, the RPA Core Team was able to call upon the technical expertise of subject matter experts to discuss the technical justifications for departures from existing U.S. requirements or minor modifications to the JRC practices as adapted for the smaller system<sup>3</sup>

<sup>2</sup> In order to accurately replicate the JRC operation of the Tokaido Shinkansen, and to minimize rounding and other errors associated with converting units of measurement, the text of this proposed rule uses the International System of Units (*i.e.*, the metric system), rather than the standard units of measurement more commonly used in the U.S. rail environment, as these are the units of measurement used by JRC.

<sup>3</sup> TCRR’s contemplated system will be smaller than JRC’s Tokaido Shinkansen in almost every way, such as overall length of system, number of

proposed in Texas. The RPA Working Group held 25 meetings from March 2014 to April 2016,<sup>4,5</sup> to discuss specific topics to be covered by the proposed RPA. The final work product of these meetings is the proposed rule text and supporting documentation included in the rulemaking docket.

On April 15, 2016, TCRR submitted to FRA its petition for an RPA to address the safe operation of a high-speed rail system in Texas, based on the Japanese Shinkansen technology. TCRR supplemented its petition in August 2016, and again in September 2017. *See* FRA Docket No. FRA–2019–0068.

TCRR’s petition contained proposed regulatory text—along with supporting technical data—providing a regulatory framework that applies the holistic “systems” approach. Specifically, through its petition, TCRR has translated and adapted the technology specific aspects of the Tokaido Shinkansen system into a format that enables effective regulatory oversight by FRA. The Tokaido Shinkansen operation ensures safe operations through application of a systems approach to safety and accident avoidance philosophy. Safety can only be ensured through a holistic approach; attention to or focus on individual aspects of the operation alone may not be sufficient. TCRR used in its development of its rulemaking petition, a previous proposed RPA for the Florida Overland eXpress (62 FR 65478), to help identify the regulatory needs of the proposed high-speed system operations, which are not currently covered by a consistent set of regulatory requirements.

FRA granted TCRR’s rulemaking petition on August 30, 2019, stating that it would undertake this rulemaking process.

### C. The Proposed System

TCRR will replicate the Tokaido Shinkansen system and its essential technologies in Texas. The TCRR system will be based on accident avoidance principles to assure that collisions or other operational risks and hazards are eliminated or reduced to the highest degree possible, as is done in Japan. The

station stops, and anticipated frequency of daily trainset departures, to name a few aspects.

<sup>4</sup> Exhibit E to TCRR’s rulemaking petition contains all the presentations that were discussed during the 25 meetings held between TCRR and FRA. All the meeting presentations are in the rulemaking docket, FRA–2019–0068.

<sup>5</sup> Additional meetings were held after the petition was submitted in April and August of 2019. Both were informational technical meetings. Copies of the presentations discussed at these meetings are included in the rulemaking docket, FRA–2019–0068.

system includes a dedicated, grade-separated, and fully fenced right-of-way, equipped with intrusion detection capabilities to detect the intrusion of unauthorized vehicles into the right-of-way. It is designed to facilitate only high-speed rail trainsets of a specific type on the right-of-way during revenue operations, with a strict temporal separation of maintenance activities. The system will have no at-grade crossings with any other rail system or surface transportation modes, such as highway vehicles. This approach ensures that the complete system mitigates any potential risks and is consistent with the N700 series trainsets that have been chosen as the service-proven rolling stock platform for TCRR.

This proposed rule requires the TCRR system to implement all the service-proven, safety-critical aspects of the Japanese Shinkansen system. It also provides for the FRA approval of the key system elements as implemented in Texas. The proposed rule text incorporates the structural characteristics of the N700 series trainset in a manner that can be regulated and enforced by FRA, and requires the system to be designed, operated, and maintained in a manner that effectively mitigates any hazard that could compromise the integrity of the trainset. Implementing the N700 series trainsets as they are currently designed (with minor modifications that do not impact the safety performance of the trainset, as further discussed below), along with the accident mitigation measures required by a systems approach and defined in the proposed rule text, will allow TCRR to replicate the service-proven system and operations of the Tokaido Shinkansen system.

FRA makes clear that this rule proposes to codify standards and practices unique to JRC’s operations that are inherent to the safe operation of this proposed service in Texas, which must be maintained and protected in order to ensure that the safety record of the Tokaido Shinkansen can be effectively transferred.

#### 1. Rolling Stock

The basis of the TCRR operation is the adoption of the Tokaido Shinkansen system with the N700 series trainset, and its variants, as the rolling stock, adapted for service in Texas. JRC’s N700 series trainsets, have been in service since 2007 on the Tokaido Shinkansen line and operate up to speeds of 300 km/h on the adjacent Sanyo Shinkansen line. The N700 trainset is an electric multiple unit (EMU) trainset design based upon an accident avoidance

philosophy to ensure safe, reliable, and efficient service. The current design has been continuously refined with these principals in mind, building on over 50 years of experience that JRC has developed, together with its rolling stock manufacturers, in the design, operation, and maintenance of integrated high-speed trainsets. This proposed rule maintains the service-proven safety and operational history of this trainset, while adapting it to the conditions unique to TCRR's operating environment.

At the time of TCRR's petition, FRA was developing its rule (now final) governing the next generation of interoperable high-speed trainsets, known as Tier III. See 83 FR 59182. A primary goal of this rule was to provide more performance-based safety standards to allow U.S. operations to benefit from the service-proven high-speed trainset designs operating throughout the world, in a manner that allows for continuous technological innovation. Because the Tier III rule considered designs and operational practices such as those used on the Tokiado Shinkansen in its development, TCRR was able to take advantage of a paradigm shift in FRA's regulatory approach to high-speed passenger rail as established by the November 2018 Passenger Equipment Safety Standards final rule. As such, the rolling stock requirements of this proposed rule, contained in proposed subpart D, focus largely on those elements that differ from the Tier III standards, either because a risk that exists on the general system has been eliminated or highly mitigated (e.g., grade crossings), or because the strict adherence to a requirement might otherwise effect the safety proven aspect of the design (e.g., suspension design). A brief explanation of substantive deviations or essential areas of note are articulated in further detail below.

#### Trainset Structure

As previously stated, the central philosophy behind the safety approach of the Tokiado Shinkansen is collision avoidance and accident prevention. By eliminating and mitigating common risks and hazards to high-speed rail operations through design and technology, the need to provide occupant protection to mitigate certain accident scenarios through carbody structural requirements can be greatly reduced. By prohibiting other types of equipment (i.e., conventional passenger and freight equipment) from operating over the same track, eliminating at-grade crossings with motor vehicles (particularly commercial equipment),

temporally separating maintenance-of-way operations, and providing enhanced train control and intrusion protection technology, a higher level of safety can be attained rather than just relying on occupant protection standards *after* an accident occurs. This allows for the trainset design to focus on reducing mass and aerodynamic inefficiencies, which not only provides improved economic and environmental performance, but also provides for additional safety through improved braking characteristics, better stability, and reduced wear on running gear and tracks.

Furthermore, since the general system requirements often drive the carbody design, FRA believes requiring them, without cause, would result in significant changes, negating the service-proven design of the N700 series trainset. This could potentially have a negative effect with respect to braking, trainset stability, and wear on the track structure and running gear.

FRA is not proposing TCRR comply with the more robust conventional U.S. crashworthiness and occupant protection requirements applicable to equipment operating over the general system, which are driven largely by train-to-train collisions and grade crossing conflicts, as these risks have been heavily mitigated through the design of the system (i.e., prohibition of both comingling with heavy freight equipment and grade crossings). However, FRA does propose to retain the crashworthiness and occupant requirements established by JRC to address potential residual risks to the operation and to ensure the trainset can handle the expected operational loads experienced in the intended service environment. Specifically, FRA proposes that TCRR demonstrate that the trainsets used in Texas have the same occupied volume integrity as those used on the Tokiado Shinkansen, verified through quasi-static compression and dynamic collision scenario testing. Additionally, FRA is proposing that TCRR also verify the trainset's resistance to override, should a collision occur. Further, FRA is proposing that TCRR demonstrate its trainsets meet the same roof and side structure integrity requirements, and truck-to-carbody attachment strength requirements, as the N700 series trainset operated by JRC.

The proposed rule requires trainset interior fittings to be securely attached and designed to operate without failure under conditions and loads to be expected in TCRR's proposed operating environment. The rule does not adopt the conventional attachment loading, as

doing so would jeopardize other safety critical designs of the service-proven N700 series trainset (e.g., the suspension system). In addition, all interior surfaces should be free of corners and sharp edges that could pose a hazard to occupants under sudden deceleration or braking events.

The proposed rule will require cab end-facing glazing to comply with Tier III requirements: Large object impact test in accordance with EN15152 and the ballistic impact resistance requirements under appendix A of 49 CFR part 223. Side-facing glazing are proposed to meet FRA's current Type II requirements, unless an alternative standard is approved, which is also what Tier III equipment must comply with. FRA welcomes comments on whether international standards exist for side-facing glazing that may be better suited for very high-speed operations, particularly those operating in dedicated and protected ROW environments as the rule proposes.

FRA believes these baseline trainset carbody requirements, to include interior fittings and glazing, will ensure that the trainset remains stable and safe for the high-speed environment it is intended to operate in, while protecting against the very low residual potential derailment and foreign object collision risks.

#### Braking System Requirements

This rule proposes requirements for the brake system based upon FRA's November 2018 Passenger Equipment Safety Standards final rule, with modifications where appropriate for technology specific to the N700 series trainset. The brake commands are transmitted through the trainset-borne network system, as well as through the trainline for redundancy. Unlike typical North American brake systems, the N700 series trainset uses a loop circuit for the urgent brake control and does not have brake pipes. The brake system of a motorized car on a N700 series trainset has a blended brake system, consisting of an electronically controlled pneumatic brake and a regenerative brake. A non-motorized car on a N700 series trainset has an electronically controlled pneumatic brake. The brake system on the N700 series trainset also has a state-of-the-art wheel slide control system.

Consistent with proper railway engineering practice, the proposed rule would require the railroad to demonstrate the maximum safe operating speed for the trainsets without thermal damage to equipment or infrastructure during normal operation of the brake system. The brake system

must be capable of stopping the trainset from its maximum operating speed within the signal spacing on the track under the realistic worst-case adhesion conditions expected. As proposed, tests on trainsets to verify the brake system performs as expected will be conducted during the pre-revenue service qualification testing proposed under subpart F. Additionally, operational restrictions based on degraded braking system performance are to be addressed by the railroad under the proposed requirements for movement of defective equipment.

The N700 series trainset braking system utilizes an “urgent” brake as defined in the proposed § 299.5. An urgent brake is equivalent to the emergency brake in the U.S. in that it produces an irretrievable stop, with maximum braking effort. The N700 series trainset has an urgent brake switch for use by the trainset crew from the controlling cab and the conductor’s room(s). The use of the urgent brake by the conductor is usually within stations to assure passenger safety when boarding and alighting from the trainset. The proposed rule requires that an urgent brake application be available at any time, and shall be initiated by an unintentional parting of the trainset or action by the trainset crew. Further, the station platform will be equipped with trainset protection switches on the station platform so that both station personnel and conductors can activate the urgent brake on the trainset in the event that they observe an unsafe condition during boarding/alighting of trainsets.

The proposed rule requires a means to initiate a passenger brake alarm at two locations in each unit of a trainset, consistent with the requirements developed for Tier III trainsets. The proposed rule does not incorporate the exception provision for length of individual cars as it is applicable to shorter designs than the N700 series trainset.

Additionally, the N700 series trainset braking system utilizes an “emergency” brake as defined in the proposed § 299.5. The emergency brake on the N700 series trainset is equivalent to the North American full-service brake.

Requirements for the main reservoir system are based on the requirements included in the November 2018 Tier III final rule, but modified to accommodate the specific design standards used for the N700 series trainset. The proposed rule requires the brake system main reservoirs in a trainset to be designed and tested to meet the pressure vessel standards in Japanese Industrial Standard JIS B 8265, “Construction of

pressure vessels-general principles.” This is the same pressure vessel standard the N700 series trainsets comply with to operate in Japan. The JIS standard adequately ensures that the pressure vessel (the main reservoir) is suitable for the service conditions under which the brake system main reservoirs will operate, ensuring that the system replicates the service-proven brake system used currently on the N700, operated on the Tokaido Shinkansen. Requiring adherence to conventional U.S. standards would not be prudent, as this would jeopardize the service-proven aspect of the design.

#### Fire Safety

The proposed rule will require interior furnishings to be compliant with current FRA flammability and smoke emission requirements under appendix B to part 238 (see, generally, the discussion of FRA’s flammability and smoke emission requirements at 64 FR 25660, 67 FR 42909, and 83 FR 59182). Many of the elements affected by fire safety standards are driven by business decisions made by the project (*e.g.*, carpeting, seating fabric, etc.) and are not inherent to the safe performance of the trainset as it related to its structure or stability at speed. Therefore, it was determined by the project that it would be appropriate to simply adopt and comply with the current U.S. standards in lieu of justifying new ones.

#### Door Systems

The proposed requirements for the trainset door systems, particularly as it relates to emergency functionality, largely follow FRA’s existing requirements and established North American practice. The relevant requirements for operating; inspection, testing, and maintenance (ITM); and training on door systems have been consolidated under their respective subparts as proposed within this rule. The proposed modifications focus mainly on how the requirements apply to the Tokaido Shinkansen technology and the applicability of certain elements of APTA SS–M–18–10. The proposal would retain the service-proven door system on the N700 series trainset, and, though FRA is not proposing to require it, TCRR is expected to adopt the coordination between the trainset crew members and platform attendants, replicating operations by JRC, rather than incorporating certain requirements that were promulgated in December 2015 for conventional U.S. operations (*see* 80 FR 76118), which, if applied, would require alteration that could have a significant negative impact on the

service-proven door design of the N700 series trainset.

#### Emergency Systems

The proposed rule defines typical North American requirements for emergency lighting, emergency communications, emergency egress and rescue access, and emergency marking requirements. A number of these provisions will require minor changes to the current N700 series trainset design, such as the emergency lighting system, public address system, and interior signage and markings. However, compliance with these proposed emergency systems requirements would not have a negative impact on the service-proven design of the N700 series trainset as they have no impact on the performance of the trainset or its integration with other safety-critical systems. These changes will also provide first-responders and the traveling public with a set of safety communications and features that are consistent with other U.S. rail operations.

#### Safety Appliances

Current FRA regulations for safety appliances are based on longstanding statutory requirements for individual railroad cars used in general service. These requirements are primarily intended to keep railroad employees safe while performing their essential job functions. Historically, these duties have revolved around the practice of building trains by switching individual cars or groups of cars, and are not directly applicable to how modern high-speed passenger equipment are designed and operated. The application of such appliances would require a significant redesign of high-speed rail equipment, and would create aerodynamic problems particularly with respect to associated noise emissions. FRA proposes to exempt TCRR from statutory requirements that are not applicable or practical for inclusion on its high-speed trainset technology, pursuant to the authority granted under 49 U.S.C. 20306.<sup>6</sup>

Rather than apply legacy requirements that are inappropriate for the proposed equipment design and service environment, this proposed rule focuses on how to provide a safe environment for crews as it pertains to the N700 series trainset, and modern high-speed operations throughout the world. In this respect, the proposed rule

<sup>6</sup> Utilization of this statutory authority necessitates a public hearing. As stated above, under **DATES**, the time and place of this public hearing will be announced by a separate announcement published in the **Federal Register**.

would define specific safety appliance performance requirements applicable to this semi-permanently coupled trainset. By focusing on the job functions, rather than mandating specific legacy designs for dissimilar equipment, the proposed approach will arguably improve safety for crews and railroad employees, but provide flexibility for superior designs based on modern ergonomics, and eliminate appliances that might otherwise encourage their use even though their functionality is moot (*e.g.*, riding on side sills despite an inability to couple/decouple cars). FRA believes it is appropriate to consider relief under the discretionary process established under 49 U.S.C. 20306 and proposes to adopt these requirements under its statutory authority as part of this rulemaking.

#### Image and Audio Recording Devices

On July 24, 2019, FRA published an NPRM regarding locomotive mounted image and audio recording devices for passenger trains. 84 FR 35712. In that NPRM, FRA proposed to require the installation of inward- and outward-facing image recording devices on all lead locomotives in passenger trains, and that these devices would record while a lead locomotive is in motion and retain the data in a crashworthy memory module. FRA also proposed to treat these recording devices as safety devices under existing FRA regulations to prohibit tampering with or disabling them.

Although the proposal for image and audio recording devices is not yet final, FRA anticipates that any final requirements for image and audio recording devices would also apply to TCRR. Currently, FRA proposes to place the image and audio recording device requirements under 49 CFR part 229. Under this proposed rule, it is stated that 49 CFR part 229 will not be applicable to the railroad's high-speed trainsets. However, FRA makes clear here that it proposes to make applicable the requirements for the image and audio recording devices to TCRR's high-speed trainsets, while leaving the remainder of part 229 inapplicable to the high-speed trainsets, and would anticipate that once the July 2019 NPRM becomes final, FRA would make appropriate conforming changes to the requirements outlined in this NPRM.

FRA acknowledges that this was not a requirement contained in TCRR's rulemaking petition, and that this is not a requirement for the Tokaido Shinkansen system as operated in Japan. However, FRA does not anticipate this requirement having a detrimental effect

on the service-proven nature of the N700 series trainset design.

#### 2. Automatic Train Control System

As an intercity passenger railroad, TCRR must comply with all applicable requirements under 49 U.S.C. 20157, including, but not limited to, the statutory requirement to fully implement an FRA-certified positive train control (PTC) system on its main lines over which intercity or commuter rail passenger transportation is regularly provided. The rule proposes to require TCRR to use the signal system based upon the service-proven Tokaido Shinkansen Automatic Train Control (ATC) system, which has demonstrated an outstanding safety record during its 55 years of operations. This system is a standalone digital ATC system, and as such, does not rely on an underlying conventional signaling system.

This proposed rule, under subpart B, outlines the requirements for signal and trainset control systems governing the operation of TCRR, based on the fundamental statutory requirements of 49 U.S.C. 20157 and 49 CFR part 236, subpart I, but is tailored for a standalone and service-proven trainset control system intended for high-speed passenger service. TCRR is proposing to implement a PTC-compliant trainset control system throughout its entire network, to include trainset maintenance facilities and depots (shop facilities), in addition to main line operation. While TCRR, in its petition for rulemaking, initially intended to comply with all elements under 49 CFR part 236, subpart I, FRA proposes to tailor the requirements to only those elements of subpart I that would apply to a standalone trainset control system intended for high-speed passenger service.

FRA notes that many of the requirements in 49 CFR part 236, subpart I were written to establish the process by which existing railroads would develop and implement PTC systems as overlays on conventional signaling systems. As TCRR is a new system, and will utilize service-proven technology that does not need to be integrated with a legacy signal system or be interoperable with other PTC systems, the requirements proposed in this rule have been streamlined to focus on the core requirements and documentation necessary to validate and certify a PTC system of its design and application. This proposal also acknowledges that if any changes are made to the service-proven, safety-critical software utilized on the Tokaido Shinkansen signaling system (such as changes to the fundamental architecture

or safety critical functions), those changes must be developed and validated in accordance with the procedures proposed under subpart B. This rule balances the service-proven history of the Tokaido Shinkansen ATC system with the fundamental fail-safe principles encompassed in FRA's regulations governing advanced trainset control technology, to ensure TCRR's system is implemented and maintained safely, in a manner consistent with U.S. law, while holding true to the collision avoidance principles on which the Tokaido Shinkansen is based.

#### 3. Track Safety Standards

All high-speed track safety standards are based on the principle that the interaction of the vehicles, and the track over which they operate, must be considered as a system. This systems approach ensures that the capabilities and limitations of both the rolling stock and the physical infrastructure (*i.e.*, track) are considered when developing safety metrics and provides for specific limits for vehicle response to track perturbation(s).

FRA's Track Safety Standards, under 49 CFR part 213, and its Passenger Equipment Safety Standards, under 49 CFR part 238, promote the safe interaction of rail vehicles with the track over which they operate. These safety standards were developed with industry stakeholder participation, and are applicable to all high-speed and high cant deficiency train operations in the United States. Last amended in March 2013 (78 FR 16052), subpart G of part 213, consolidated repetitive guidance found in part 238, and revised existing minimum safety limits for vehicle response to track perturbations and also added new limits. FRA's rules are not applicable to one vehicle type, but account for a range of vehicle types (like vehicles with variations in their physical properties, such as suspension, mass, interior arrangements, and dimensions that do not result in significant changes to their dynamic characteristics) that are currently used and may likely be used on future high-speed or high cant deficiency rail operations, or both. FRA's high speed/high cant deficiency regulations are based on the results of simulation studies designed to identify track geometry irregularities associated with unsafe wheel/rail forces and accelerations, thorough reviews of vehicle qualification and revenue service test data, and consideration of international practices.

Track Classes

FRA differentiates track classes by speed. Existing regulations contain requirements for track classes 1–5, for speeds not exceeding 90 mph, and track classes 6–9 for operations up to 220 mph. In the 2013 final rule, FRA stated that the Class 9 standards would remain as benchmark standards with the understanding that the final suitability of track safety standards for operations above 150 mph would be determined by FRA after examination of the entire operating system, including the subject equipment, track structure, and other system attributes. FRA explained that direct FRA approval is required for any such high-speed rail operation, whether through an RPA such as this or another regulatory proceeding.

The basis of the TCRR operation and this proposed rule, however, is adoption of the Tokaido Shinkansen system, using the series N700 series trainset, and its variants, as the only rolling stock for a fully dedicated, grade-separated, high-speed rail service between Dallas and Houston, TX. JRC’s N700 series trainsets have been in service since 2007 and operate at the speed of 285 km/h on the Tokaido Shinkansen and 300 km/h

on the Sanyo Shinkansen. As stated previously, the N700 series trainset is a service-proven EMU trainset design that has been continuously refined, and highly optimized by JRC for over 50 years.

JRC’s track safety standards have evolved concurrently with these N700 Shinkansen EMU trainsets, allowing for a high degree of optimization of the trainset interacting with the track structure. TCRR plans to replicate the Tokaido Shinkansen system to bring the same safety and performance of the Shinkansen system to this Dallas-Houston operation. This rule proposes to adopt the same JRC-derived track safety standards to ensure that this optimized vehicle-track interaction is achieved between Dallas and Houston in its entirety. Therefore, this proposal would require the railroad to follow the JRC approach for the definition of track classes, track geometry limits, carbody acceleration criteria, and track inspection intervals for both automated and visual inspection on all TCRR track Classes at all speeds up to and including the maximum track speed of 330 km/h.

JRC defines track and the speed range by function (*i.e.*, main track, etc.), and

not by a track class designation. However, in this proposed rule, the JRC practice has been translated into eight classes of track from track Classes H0 to H7. As stated, the maximum authorized speed from track class is based on current JRC practice with the addition of track Class H7, which covers operating speeds up to 305 km/h. It is notable that in this proposal, track Class H0 will be dedicated to maintenance-of-way equipment, with a maximum allowable operating speed of 20 km/h (12 mph), which is consistent with JRC practice. As is done in Japan, this proposal would prohibit high-speed trainsets from operating on the proposed track Class H0. Below is a table outlining the proposed classes of track, the associated maximum operating speed for that class, and where that class of track is proposed to be used within the system. The table is not meant to dictate that these are the only locations for the various classes of track to be located within the TCRR system, but meant to represent FRA’s general understanding of how TCRR will use the various track classes.

TRACK CLASSES—MAXIMUM SPEED

	H0	H1	H2	H3	H4	H5	H6	H7
km/h .....	20	30	70	120	170	230	285	330
mph .....	12	19	43	75	106	143	177	205

Track type

	Maintenance-of-way yards	Trainset Maintenance Facilities (TMF).	Terminals, stations, sidings, TMF marshaling tracks.	Main line track, and track connecting the main line with TMF.	Main line track.

Track Geometry

The proposed track safety standards for TCRR are under subpart C of this proposed rule. Within that proposed subpart, FRA has included certain track geometry requirements for the TCRR system. The geometry limits proposed by FRA are based on JRC practice. Likewise, FRA proposes to adopt the JRC practice for remedial action for instances when optimal track geometry limits and car body accelerations are exceeded, and trainset operations would require speed and/or operational restrictions, with speed restrictions enforced by the ATC system.

The highly effective JRC track measurement system is based on monitoring track geometry and vehicle performance, and represents a hybrid approach consisting of physical measurements directly on the track, in combination with performance-based track geometry as defined by vehicle

response. TCRR will adopt this approach which is based on a 10 m mid chord offset (MCO) measurement to effectively control short wavelength track geometry irregularities and the measurement of car body accelerations to control long wavelength anomalies.

TCRR is adapting and implementing the same track geometry limits and car body accelerations utilized by JRC to ensure the continued success of this vehicle-track system and the optimized performance of the N700 series trainset. The JRC approach is very different from FRA, and is based on measuring track gauge, cross-level, and twist over 2.5 m, and alignment/surface on a 10 m MCO, with long wavelength defects controlled by monitoring car body acceleration. The JRC track measurement system adequately controls track geometry for short and longer wavelengths (20 and 40 m) such that wheel/rail forces are well within acceptable limits. TCRR is using

JCR’s geometry limits for the 10 m MCO and car body acceleration limits, both of which will be enforced by FRA, thereby ensuring the trainset’s track/vehicle system meets FRA’s safety criteria (wheel/rail forces) for track maintained to those geometry and acceleration limits.

Inspection, Testing, and Maintenance for Track

Inspection, testing, and maintenance requirements for the track and right-of-way are found generally in the proposed regulatory text, and in greater detail within the FRA-approved ITM program. The proposed track maintenance requirements are based on JRC practice, which is grounded in significant testing and many years of proven JRC operation. The JRC approach for the high-speed track layout and structure is optimized for the safe and efficient operation of the N700s trainset utilized.

As mentioned throughout this NPRM, TCRR will implement a track maintenance program based on these successful and well respected JRC practices.

JRC uses a dedicated, multi-purpose, vehicle-based, inspection system to inspect track geometry. Track geometry measurements and car body accelerations are made during revenue operations at revenue operating speeds. This proposal reflects U.S. and JRC practice with respect to track geometry measurements. FRA proposes to require a track geometry measurement system (TGMS) and a track acceleration measurement system (TAMS) to be operated over the system route on track Classes H3 and above.

Regarding restoration or renewal of track under operating conditions, this proposed rule will prohibit the railroad from performing maintenance-of-way operations during revenue service, other than in MOW yards and trainset maintenance facilities, as further discussed below. Restoration or renewal of track by TCRR on track Class H2 in trainset maintenance facilities, will be limited to the replacement of worn, broken, or missing components or fastenings that do not affect the safe passage of trainsets. This will reflect the JRC practice and is more restrictive than existing FRA track safety standards as it permits such restoration and renewal under traffic conditions only in yards and trainset maintenance facilities and not the mainline.

#### Vehicle/Track Interaction

The approach to vehicle/track interaction (VTI) system safety in this rule proposes to follow JRC's approach that is service-proven to provide safe operation and optimum VTI performance. JRC places considerable emphasis on maintaining track infrastructure, as the Tokaido Shinkansen N700 series trainset suspension design is optimized for high-speed performance on well-maintained track. Track geometry irregularities are held to tighter tolerances than those allowed under U.S. practice.

The VTI requirements FRA proposes are similar to those contained in current FRA regulations under 49 CFR part 213, and will require the trainsets to comply with the same wheel/rail force limits. However, as noted earlier, JCR requires more stringent peak-to-peak car body acceleration limits than currently permitted under FRA regulations. Accordingly, FRA proposes that instrumented wheelset tests be required for vehicle/track system qualification.

Unique to the Tokaido Shinkansen system, and as mentioned earlier, JRC

sets track geometry limits based on a 10 m MCO and controls long wavelength perturbations using stringent vertical and lateral car body accelerations, rather than the 3-chord (31, 62, and 124 ft) method used in current FRA regulations. Vehicle dynamic simulations have been conducted and validated by JRC specialists to demonstrate the 10m MCO and car body accelerations, as used by JRC, are sufficient to safely control short, long wavelength, and repeated perturbations; and to validate the proposed track geometry limits contained in the proposed rule.<sup>7</sup>

#### Continuous Welded Rail

TCRR is proposing to use continuously welded rail (CWR) and moveable point frogs to eliminate gaps at turnouts and crossings. Consistent with current FRA practice for CWR, FRA proposes to require the railroad develop and comply with its own CWR plan, which will have procedures addressing the installation, adjustment, maintenance, and inspection of CWR and CWR joints. However, as the FRA CWR requirements under 49 CFR part 213 are inconsistent with JRC technology and practices, FRA proposes a set of CWR requirements that reflects JRC's service-proven practice. Under this rule as proposed, TCRR will be required submit a CWR plan that includes procedures for maintaining a desired rail installation temperature range when cutting CWR, and with adjustments made to tight track or a track buckle.

In addition to the proposed requirements discussed above, FRA is also proposing to require TCRR's CWR plan to contain procedures that control trainset speed on CWR track when the difference between the rail temperature and the rail neutral temperature is in a range that causes buckling-prone conditions to be present at a specific location. This proposed requirement is consistent with JRC practice, which uses "instantaneous" temperature, a more stringent requirement, instead of "average" temperature. When the temperature exceeds a specified limit,

<sup>7</sup> Exhibit F to TCRR's rulemaking petition explains how JRC helped develop and validated the track geometry limits proposed in this NPRM, and provides some explanation of the vehicle dynamic simulations conducted. Although the Tokaido Shinkansen operates at a maximum speed of 270 km/h, the vehicle dynamic tests used to validate the track geometry limits proposed in this NPRM were conducted at simulated speeds up to 340 km/h (330 km/h + 10 km/h). FRA notes, though, that the maximum safe operating speed for the system will be determined only after TCRR conducts full scale analysis and validated dynamic testing, as proposed under subpart F.

operational restrictions are enforced over the entire segment. JRC uses the same temperature limits on all segments.

FRA is also proposing that the railroad's CWR plan include procedures that address track inspections under extreme temperature conditions, consistent with JRC practice. As stated previously, there is continuous monitoring of rail temperature on the Tokaido Shinkansen system and a speed restriction of 70 km/h is enforced when CWR temperature is between 60 °C and 64 °C. JRC suspends revenue operations and conducts visual inspections on foot when the CWR temperatures reach 64 °C or above.

#### 4. Maintenance-of-Way Operations

Strict adherence to complete temporal separation of the scheduled right-of-way maintenance work will be required by the proposed rule. This rule proposes to adopt JRC's long-established maintenance-of-way operational practices to ensure roadway worker safety. To accomplish this, the rule proposes requirements for strict adherence to temporal separation of maintenance-of-way operations and revenue trainsets, as well as removal of overhead power from the section(s) of ROW where maintenance-of-way work is being performed. Additionally, this rule proposes prohibiting the railroad from conducting any scheduled maintenance on a section of the right-of-way prior to that section of the right-of-way being cleared after revenue service. Further, the railroad will also be prohibited from conducting revenue service on a section of the right-of-way before completion of the maintenance activities and clearance by a sweeper vehicle. As proposed by this rule, the ATC system must also enforce the temporal separation or otherwise protect maintenance-of-way employees performing on-track duties (to include unscheduled and emergency inspections or repairs).

TCRR will use maintenance-of-way equipment that is designed to be compatible with the track safety standards under proposed subpart C. Subject to certain exceptions, as proposed under § 299.3(c)(24), the railroad's maintenance-of-way equipment will be subject to FRA's existing regulations that address the safety of conventional locomotive and freight equipment (*i.e.*, 49 CFR parts 215, 223, 229, 231, and 232). Although there is a general prohibition that freight equipment cannot operate on the railroad's right-of-way, the freight equipment being considered here is



strictly for non-revenue, right-of-way maintenance operations.

The railroad's proposed maintenance-of-way fleet will include a sweeper vehicle. As part of this rule, FRA is also proposing that sweeper vehicles run on both tracks along the full length of the railroad right-of-way every day prior to the start of revenue service, in order to ensure that there are no obstacles on the tracks within the lower construction clearance envelope, consistent with the practice of JRC. The sweeper vehicle is designed to detect the presence of any small obstacles, such as tools left out from a roadway worker gang. Additionally, the qualified individuals operating the sweeper vehicle will be required to be trained to conduct visual inspections of both tracks to ensure the integrity of the right-of-way, including the condition of fencing and other railroad infrastructure. Strict adherence to this temporal separation, protection of maintenance-of-way work by use of the ATC system, and the daily requirement for sweeper vehicle use will help ensure that there are no maintenance-of-way equipment, no heavy maintenance tools, and no obstruction hazards on the tracks when the revenue service starts every day.

## 5. System Qualification

### Responsibility for Verification Demonstrations and Tests

Under proposed subpart F, FRA proposes a set of pre-revenue qualification testing requirements that the railroad must complete before commencing passenger service. Successful completion of the proposed testing program will provide the railroad assurance that the system, as designed, constructed, and integrated, will meet the minimum safety requirements established, so that the risk to passengers is minimized when operations begin. This proposed subpart F is organized such that the approach to system qualification generally requires the preparation of a system-wide qualification test plan, pre-operational qualification testing of individual components and sub-systems, and then pre-revenue service testing that verifies the compatibility of the various sub-systems. Finally, a period of simulated revenue operations is proposed that would replicate revenue operations without passengers. This would provide final verification that the systems operate as intended, all safety-critical personnel are adequately trained, and operating rules or practices and the inspection, testing, and maintenance program are appropriate.

### Preparation of System-Wide Qualification Test Plan

As proposed, prior to execution of any system qualification tests, the railroad will develop a system-wide qualification test plan that identifies the tests necessary to demonstrate the operability of all system elements, including: Track and infrastructure, signal, communications, rolling stock, software, operating practices, and the system as a whole. The system-wide qualification plan will include procedures for functional and performance qualification testing, pre-revenue service systems integration testing, vehicle/track system qualification, and simulated revenue operations, all discussed further below.

The proposed provisions include FRA's review timeframe (180 days prior to testing) and expected FRA response time (45 days after receipt of the submission) and actions. FRA will identify in the notification any test procedures requiring approval by FRA. The system-wide qualification test plan is generally consistent with current FRA practice under 49 CFR part 238 for passenger equipment, but addresses the system holistically. Under this proposal, TCRR will be required to develop a list of all tests to be conducted to qualify all aspects of the system including rolling stock, track, vehicle-track interaction, and signaling. FRA makes clear that, as proposed, FRA's approval of the system-wide test plan will be limited to approving that the test plan addresses all required tests, providing procedures for such tests; however, FRA is not approving the specific procedures adopted by the railroad to conduct each required test.

### Functional and Performance Qualification Tests

Also proposed in this NPRM is a requirement that the railroad will conduct functional and performance qualification tests, prior to commencing revenue operations, to verify that all safety-critical components meet all functional and all performance specifications. The railroad will be required to submit a list of all tests to be conducted, along with the test procedures, as part of its system-wide qualification test plan, as discussed above.

### Pre-Revenue Service Systems Integration Testing

The pre-revenue service testing of systems proposed in this NPRM will be used to verify the compatibility of the various sub-systems. The pre-revenue service testing will include such things

as: Vehicle clearances to structures along the right-of-way; mechanical performance of the overhead catenary system; and the integrated performance of the track, signal, power supply, vehicle, software, and communications. Also, the railroad will be required to demonstrate safe system performance during normal and degraded operating conditions. These tests will be used to verify: Catenary and pantograph interaction; incremental increases in trainset speed; braking rates; and vehicle-track interaction.

### Vehicle/Track System Qualification

As discussed above, under the proposed track safety standards, the approach to VTI system safety in this rule proposes to follow JRC's approach that is service-proven to provide safe operation and optimum VTI performance. As part of the system wide test plan, FRA proposes to require the railroad to qualify its high-speed trainset for the maximum operating speed and cant deficiency contemplated. The format proposed largely follows current FRA practice, with the qualification criteria based on JRC requirements for the N700 series trainset currently operating on the Tokaido Shinkansen system.

### Simulated Revenue Operations

FRA is also adopting TCRR's proposal that the railroad conduct a period of simulated revenue operations, replicating most, if not all, aspects of revenue operations, but without passengers. This will provide the final verification that the system, and all sub-systems, operate as intended, together with all properly trained, safety-critical personnel. Further, the proposed simulated revenue operations will give valuable operational experience to the railroad and its employees prior to carrying passengers.

The proposed provision will assure that all issues found during simulated revenue operations are properly addressed and corrected prior to the start of revenue service. It is not anticipated that issues found during simulated revenue operations would extend the period for testing if the specific deficiencies found were adequately rectified during that period; however, FRA would expect the start of revenue operations to be postponed, if necessary, to properly and thoroughly correct any such deficiencies.

### Verification of Compliance

Under this proposed subpart F, FRA proposes to require the railroad to prepare a report detailing the results of all functional and performance

qualification testing, pre-revenue service systems integration testing, and vehicle/track system qualification tests. The report will also require the railroad to outline the remedial measures necessary to correct any deficiencies discovered during the testing. In addition, FRA also proposes that the railroad be required to implement the improvement measures discussed in the report. With the exception of reports related to vehicle/track system qualification, verification of braking rates, and field testing data related to the ATC system, FRA proposes that the railroad submit the report prior to commencement of simulated revenue operations. For the reports regarding vehicle/track system qualification and verification of braking rates, FRA proposes they be submitted for review and approval at least 60 days prior to the start of revenue service. Certification of the railroad's PTC system must also be achieved prior to the start of revenue service.

FRA also proposes to require the railroad to obtain FRA approval of the test procedures used for the verification of any major upgrades to safety-critical system component(s) or sub-systems, or prior to introducing new safety-critical technology.

#### 6. Inspection, Testing, and Maintenance General Requirements

This NPRM proposes general requirements for inspection, testing, and maintenance under subpart G. The program will provide detailed information, consistent with the requirements set forth in §§ 299.337 through 299.349, 299.447(a), and 299.207. The conceptual basis for the proposed requirements under subpart G stems from FRA's practice regarding the inspection, testing, and maintenance of high-speed trainsets, originally set forth in subpart F of 49 CFR part 238. The underlying premise for this proposed approach is to tailor the performance-based requirements of the ITM program to the specific needs of the equipment or infrastructure, rather than specifying static maintenance intervals with explicit requirements. This approach has proven successful since it was first adopted for Tier II high-speed equipment, and therefore, FRA proposes to expand the practice for other critical areas requiring a similar performance-based approach to ITM. The general requirements within proposed subpart G specify that the railroad will develop an inspection, testing, and maintenance program to address all aspects of the operation—track, rolling stock, and signal and trainset control.

The NPRM proposes that submittal of the initial inspection, testing, and maintenance requirements associated with the bogie inspection and general overhaul can be at a later date. However, the proposal requires that the railroad submit the requirements to FRA no later than 180 days prior to the first scheduled bogie inspection or general overhaul, so that FRA has time to review and approve the associated inspection, testing, and maintenance requirements.

FRA proposes the initial inspection intervals for safety-critical items, including those covered in the bogie inspection and general overhaul, are covered by §§ 299.13(c)(1) and 299.907(a), to be based upon JRC's service inspection, testing, and maintenance practice to ensure the integrity and safe operation of the entire system, as required in § 299.13(c)(2). Additionally, the inspection, testing, and maintenance program for safety-critical items is subject to FRA approval under § 299.913.

#### ITM Program Format

As discussed above, FRA proposes to limit the scope of its approval to only those items deemed safety-critical to the operation of the system. However, FRA does propose to require the railroad submit the entire ITM program for review to make sure all safety-critical items have been properly identified and accounted for by the railroad. Accordingly, FRA proposes that the procedures for safely performing the necessary inspections, testing, and maintenance or repairs submitted to FRA for approval should only be those designated as safety-critical or potentially hazardous tasks as required by § 299.911(b).

Additionally, FRA proposes that the railroad review the inspection, testing, and maintenance procedures annually to enable the railroad to review any pertinent operational changes or conditions that may result in modifications to the safety-critical aspects of the inspection, testing, and maintenance program. Under this proposal, FRA can participate in the annual review. The annual review would be conducted to identify necessary modifications to procedures or intervals. While FRA may determine it is not necessary to participate in the annual review in a particular year, any amendment to the safety-critical portions of the ITM will need FRA approval prior to implementation.

#### 7. Operating Rules and Practices

Under proposed subpart E, this NPRM proposes that the railroad develop,

maintain, adopt, and comply with a code of operating rules, timetables, and timetable special instructions, along with procedures for instruction and testing of all employees involved with the movement of rail vehicles prior to commencing revenue operations.

FRA also proposes to require that the railroad's initial code of operating rules, timetable, and timetable special instructions be based on the service-proven practices and procedures used by JRC on the Tokaido Shinkansen system. FRA acknowledges that as the project matures, changes to the code of operating rules, timetable, and timetable special instructions that deviate from JRC practice may become necessary due to the uniqueness of the individual operation. However, FRA still expects that whatever changes are made to the code of operating rules, timetable, and timetable special instructions, they will remain consistent with JRC practice, and provide the same level of safety and performance.

It is important to note that, unlike what was included in the railroad's rulemaking petition, FRA does not propose to expressly approve the railroad's code of operating rules, timetable, and timetable special instructions. Rather, FRA proposes to remain consistent with current U.S. practice, with respect to the approval. FRA does, however, propose to retain the ability to disapprove the code of operating rules, timetable, and timetable special instructions in whole or in part, for cause stated, and at any time.

#### 8. Personnel Qualification

This proposal follows FRA's current practice of requiring employees who perform safety related duties to be qualified to perform those duties under a training program developed by the railroad. The railroad will be responsible for developing the curriculum for the program and ensuring that specific training requirements outlined in relevant sections of this NPRM, or applicable FRA regulations of general applicability, are properly included. Based on the railroad's rulemaking petition, the qualification training program will be modeled on JRC's training program in Japan.

Although a separate subpart addressing personnel qualifications was proposed in TCRR's petition for rulemaking, FRA has decided that proposing a separate subpart is unnecessary. The proposed subpart, as drafted by TCRR, required compliance with 49 CFR part 243 and contained additional, specific training requirements for track inspectors. As 49

CFR part 243 is proposed as applicable to the railroad under § 299.3(c), there is no need for a separate subpart to so state. Additionally, since the additional training requirements were specific to track inspectors, FRA has moved those provisions under proposed subpart C, which addresses track safety, thus fully obviating the need for the subpart.

#### *D. Applicability of FRA's Current Regulations*

The proposed rule holds the railroad ultimately responsible for compliance with all aspects of the proposal, along with certain existing FRA regulations. In its petition, TCRR proposed to comply with the pertinent existing FRA regulations contained generally in 49 CFR parts 200–299, as listed in § 299.3(c), that are speed and technology neutral. After further review of those rules, there are certain additional provisions that are not appropriate for this system. Those individual sections are specifically excluded under § 299.3(c).

FRA also notes that there are many sectional cross-references within applicable FRA regulations to other FRA regulations that are not applicable to this project, such as 49 CFR parts 213, 217, subpart I of 236, and 238. Without specifically addressing each instance, FRA makes clear that where such a cross-reference exists in the applicable regulations enumerated under § 299.3(c)(1) through (23), the railroad will instead comply with the equivalent requirements proposed in this NPRM. For example, where there is a cross-reference to a section under 49 CFR part 213, which deals with track safety standards, or 49 CFR part 217, which deals with railroad operating rules and practices, the railroad would instead refer to, and comply with, subpart C for the applicable track safety requirements, or subpart E for the applicable requirements addressing operating rules and practices.

#### *E. Incorporation by Reference*

FRA proposes to incorporate by reference six Japanese Industrial Standards (JIS) and three ASTM International (ASTM) standards. As required by 1 CFR 51.5, FRA has summarized the standards it proposes to incorporate by reference and has shown the reasonable availability of those standards here. The Japanese Industrial Standards are reasonably available to all interested parties online at [www.jsa.or.jp](http://www.jsa.or.jp) (Japanese site), or [www.jsa.or.jp/en](http://www.jsa.or.jp/en) (English site). Additionally, the ASTM standards are reasonably available to all interested parties online at [www.astm.org](http://www.astm.org). Further,

FRA will maintain a copy of these standards available for review at the Federal Railroad Administration, Docket Clerk, 1200 New Jersey Avenue SE, Washington, DC 20590.

Under § 299.13(d)(4) and (5), FRA proposes to incorporate by reference three versions of JIS E 1101, “Flat bottom railway rails and special rails for switches and crossings of non-treated steel.” JIS E 1101:2001 addresses the manufacturing of the steel rail. It specifies the quality and the tests for flat bottom railway rails of non-treated steel with a calculated mass of 30 kg/m or more and special rails for those railway switches and crossings. JIS E 1101:2006 and JIS E 1101:2012 amend JIS E 1101:2001 by updating references to other cited standards (e.g., updating the title to the cited reference), updating references to specific clauses within a cited standard, or by deleting a reference to a cited standard. By incorporating these standards by reference, FRA will make certain that the rail side of the wheel-rail interface remains identical to that used on the service proven high-speed lines of JRC, by ensuring that the rail is manufactured to the same specifications as the rail used on the Tokaido Shinkansen system.

Under § 299.403(b), FRA proposes to incorporate by reference two versions of JIS E 7105 “Rolling Stock—Test methods of static load for body structures.” JIS E 7105:2006 addresses test methods for trainset carbody. It specifies the test methods of static load for confirming strength, rigidity and the like of body structures for passenger stock such as electric railcars, internal-combustion railcars and passenger cars principally. JIS E 7105:2011 amends JIS E 7105:2006 by updating references to other cited standards (e.g., updating the title to the cited reference), updating references to specific clauses within a cited standard, or by updating specifications from the 2006 version. By incorporating these standards by reference, FRA will maintain the same strength and rigidity of TCRR’s trainset carbody structure. This will help preserve the occupied volume from premature degradation due to typical in-service loads and vibration.

Under § 299.409(g), FRA proposes to incorporate by reference JIS B 8265 “Construction of pressure vessels-general principles,” published December 27, 2010. JIS B 8265 addresses manufacturing of pressure vessels and specifies certain requirements for the construction and fixtures of pressure vessels with the design pressure of less than 30 MPa. By incorporating this standard by reference,

FRA will ensure that the pressurized air reservoirs used in TCRR’s trainset are designed and constructed to the same service-proven standard as used in the N700 trainsets currently operated on the Tokaido Shinkansen system.

Under § 299.423(e)(1), FRA proposes to incorporate by reference ASTM D 4956–07<sup>e1</sup> “Standard Specification for Retroreflective Sheeting for Traffic Control,” approved March 15, 2007. ASTM D 4956–07<sup>e1</sup> covers flexible, non-exposed glass bead lens and microprismatic, retroreflective sheeting designed for use on traffic control signs, delineators, barricades, and other devices.

Under § 299.423(e)(1) and (f)(3), FRA proposes to incorporate by reference ASTM E 810–03 “Standard Test Method for Coefficient of Retroreflection of Retroreflective Sheeting Utilizing the Coplanar Geometry,” approved February 10, 2003. Test method ASTM E 810–03 describes an instrument measurement of the retroreflective performance of retroreflective sheeting.

Under § 299.423(e)(2), FRA proposes to incorporate by reference ASTM E 2073–07 “Standard Test Method for Photopic Luminance of Photoluminescent (Phosphorescent) Markings,” approved July 1, 2007. FRA is also proposing to incorporate by reference Section 5.2 of ASTM E 2073–07 under § 299.423(e)(2)(ii). Test method ASTM E 2073–07 covers a procedure for determining the photopic luminance of photoluminescent (phosphorescent) markings. It does not cover scotopic or mesopic measurements.

Incorporation of the three ASTM standards by reference is to ensure that the materials used for interior and exterior emergency markings can provide adequate photoluminescence or retroreflectivity. As the markings utilizing these materials will be relied on during emergencies (either for passenger to egress or first responders to gain access), it is important that the marking can be easily identified and followed should the emergency occur during hours of limited visibility with possible degradation or complete loss of interior lighting. The standards either provide performance specifications for design and manufacture, or provide the testing methods.

#### *F. Enforcement*

FRA may impose civil penalties on any person, including the railroad or an independent contractor providing goods or services to the railroad, that violates any requirement of this rule. These penalty provisions parallel the civil penalty provisions for numerous other

railroad safety regulations, and are authorized by 49 U.S.C. 21301, 21302, 21303, and 21304. Any person who violates a requirement of this rule may be subject to civil penalties between the minimum and maximum amounts authorized by statute and adjusted for inflation per violation.<sup>8</sup> Individuals may be subject to penalties for willful violations only. Where a pattern of repeated violations, or a grossly negligent violation creates an imminent hazard of death or injury, or causes death or injury, an aggravated maximum penalty may be assessed.<sup>9</sup> In addition, each day a violation continues constitutes a separate offense. Finally, a person may be subject to criminal penalties under 49 U.S.C. 21311 for knowingly and willfully falsifying reports required by these regulations. FRA believes that inclusion of the penalty provisions is important in ensuring that compliance is achieved. See 49 CFR part 209, appendix A for a detailed statement of the Agency's enforcement policy.

Consistent with FRA's final rule regarding the removal of civil penalty schedules from the CFR, please see 84 FR 23730 (May 23, 2019), FRA will not publish a civil penalty schedule for this rule in the CFR, but plans to publish a civil penalty schedule on its website. Because such penalty schedules are statements of agency policy, notice and comment are not required prior to their issuance, nor are they required to be published in the CFR. See 5 U.S.C. 553(b)(3)(A). Nevertheless, commenters are invited to submit suggestions to FRA describing the types of actions or omissions under each regulatory section that would subject a person to the assessment of a civil penalty. Commenters are also invited to recommend what penalty amounts may be appropriate, based upon the relative seriousness of each type of violation.

## V. Regulatory Impact and Notices

### A. Executive Orders 12866, 13771, and DOT Regulatory Policies and Procedures

The TCRR high-speed system is modeled on the Tokaido Shinkansen high-speed system, which does not meet many of the current requirements under the Passenger Equipment Safety Standards final rule, published

November 21, 2018 (83 FR 59182). TCRR desires to maintain the safety record of the Tokaido Shinkansen high-speed system, so it is imperative that the system approach to safety and philosophy of the JRC system be implemented as it is in Japan. As such, TCRR is requesting, through the proposed RPA, that they comply with regulations that are more stringent than the current Tier III standards.

FRA has a regulatory program that addresses equipment, track, operating practices, and human factors in the existing, conventional railroad environment. However, significant operational and equipment differences exist between the system proposed by TCR and existing passenger operations in the United States. In many of the railroad safety disciplines, FRA's existing regulations do not address the operational characteristics of the proposed TCRR system. Therefore, to ensure that this new system will operate safely, minimum Federal safety standards must be in place when TCRR commences operations.

FRA is proposing to regulate the TCRR system as a standalone system. FRA stated in the Tier III final rule that a standalone system would have to combine all aspects of railroad safety (such as operating practices, signal and train control, and track) that must be applied to the individual system. Such an approach covers more than passenger equipment and would likely necessitate particular right-of-way intrusion protection and other safety requirements not adequately addressed in FRA's regulations. FRA continues to believe that addressing proposals for standalone high-speed rail systems on a case-by-case basis and comprehensively (such as through an RPA or other specific regulatory action(s)), is prudent because of the small number of potential operations and the possibility of significant differences in their designs.

Without the proposed RPA, TCRR would not be allowed to implement their proposed system as it does not meet the requirements outlined under the Tier III rule. The proposed regulation, as a rule of particular applicability, was not subject to review under Executive Order (E.O.) 12866.

FRA concluded that because the NPRM generally includes only voluntary actions or alternative action that would be voluntary, the NPRM does not impart additional burdens on regulated entities. This proposed rule is expected to be an E.O. 13771 deregulatory action. Details on the estimate cost savings of this proposed rule can be found below.

### 1. Costs

Since TCRR, in its rulemaking petition, requests regulatory requirements that may exceed those currently imposed upon other railroads, there are no assumed new costs associated with the NPRM, as any additional burdens placed onto TCRR are voluntarily assumed. TCRR is assuming this burden to ensure that the Tokaido Shinkansen system can be fully implemented, as it is currently used by JRC. Both TCRR and FRA believe that a complete system approach to safety is needed to maintain the over 50-year exemplary safety record that the Tokaido Shinkansen system has experienced in Japan. As such, TCRR is willing to assume the additional burden by voluntarily requesting regulatory requirements that exceed what is currently imposed on other railroads.

### 2. Benefits

TCRR will replicate the Tokaido Shinkansen system, adapting the system and its essential technologies to the geographic and environmental conditions in Texas. The TCRR system is based on accident avoidance principles to assure collisions and other operational risks and hazards are eliminated or reduced to the highest possible degree. The system includes a dedicated, grade-separated, and fully fenced right-of-way with intrusion detection capabilities. It will be designed only for high-speed trainsets of a specific type on the right-of-way during revenue operations, and implements a strict temporal separation of maintenance activities (*i.e.*, maintenance will be done at night when there are no passenger train operations).

The safety features of the TCRR system will be unique in this country and do not exist in combination on any other existing North American railroad. The proposed rule will require the TCRR system to implement all service-proven, safety-critical aspects of JRC's Tokaido Shinkansen system. Additionally, the proposed rule incorporates the structural characteristics of JRC's N700 series trainset in a manner that can be regulated and enforced by FRA. The NPRM also requires the system to be designed, operated, and maintained in a manner that effectively mitigates any hazard that could compromise the integrity of the trainset. Implementing the Tokaido Shinkansen N700 series trainsets as they are currently designed, along with the accident mitigation measures required by a systems approach, and defined in the proposed rule, will allow TCRR to replicate the

<sup>8</sup>DOT publishes notices in the *Federal Register* announcing when it adjusts the minimum and maximum civil penalties. When adjustments are made, FRA publishes such adjustments on its website. Please visit FRA's website for the current minimum and maximum civil penalty amounts at <https://railroads.dot.gov/>.

<sup>9</sup>Please visit FRA's website for the current aggravated maximum penalty amount at <https://railroads.dot.gov/>.

service-proven system and operations of the Tokaido Shinkansen system.

The replication of the Tokaido Shinkansen high-speed system by TCRR will allow TCRR to achieve a degree of safety that is at least as great or greater than would be achieved while complying with existing FRA safety standards and regulations.

This proposed rule would facilitate the creation of a new high-speed passenger railroad operating between Dallas and Houston, Texas, utilizing the existing Tokaido Shinkansen technology that is currently in service in Japan. Without the proposed rulemaking, TCRR would incur potentially significant costs (and potentially lower system performance) to comply with existing FRA regulations, or would need to seek waivers of those regulations that would not provide long term regulatory certainty. In either event, such costs and uncertainty could potentially leave the project financially infeasible. If that were the case, potential users of the new high-speed rail service between Dallas and Houston would lose the consumer surplus gains that they would otherwise enjoy, and any external societal benefits associated with modal shift for passenger travel between the two cities would be lost as well.<sup>10</sup>

As the Tokaido Shinkansen high-speed system is a service-proven system, FRA believes that the proposed rulemaking is the best course of action to ensure that the public is provided with the highest level of safety, while still providing regulatory clarity to TCRR.

### 3. Alternatives

FRA provides two alternatives to the proposed RPA: The “No Action” alternative where, without the proposed rule, TCRR could decide to not pursue the Tokaido Shinkansen high-speed system and instead pursue a system that could be built using the current Tier III standards, or where TCRR could elect to comply with FRA’s existing regulations where the TCRR equipment and procedures may conflict, necessitating a comprehensive set of waivers from existing FRA standards.

#### “No Build” Alternative

Under one of the potential baseline alternatives, the “No Build” alternative, without the proposed RPA TCRR could decide not to pursue the construction of its Tokaido Shinkansen high-speed system and instead could pursue to

build a high-speed system that complies with the current Tier III standards.

JRC would most likely not allow TCRR to use the Tokaido Shinkansen high-speed system if it was modified it to adhere to the current Tier III standards. In this event, TCRR would need to design and develop a brand new high-speed system. In addition to the high costs of designing and developing a new high-speed system, there would be high levels of uncertainty associated with the overall safety performance of the system, especially when compared to the Tokaido Shinkansen high-speed system. Any new system that TCRR creates would lack the proven safety record of the Tokaido Shinkansen high-speed system. FRA believes it is unlikely that TRR would build this system under this alternative.

#### Waivers of Compliance

As an alternative to redesigning the Tokaido Shinkansen system to comply with FRA’s existing regulations, TCRR could apply for waivers of compliance. The continual renewal of waivers would impose a large paperwork burden on TCRR as it would need a waiver for a large portion of its operations, since the proposed system differs greatly from the Tier III standards.<sup>11</sup> Furthermore, waivers are revocable, and provide approval that can be subject to change and conditions.<sup>12</sup>

This uncertainty of the longevity of waiver approval could hinder the financing and implementation of the TCRR system. In addition to investor uncertainty, if waivers are revoked in the future, there is the potential that the TCRR system would need to stop revenue service, which could have a large impact on passengers who desire to use the high-speed rail system.

FRA also believes that not regulating the system holistically could impose burdens on the Tokaido Shinkansen system and operations that could be detrimental to the overall safety of the system. The Tokaido Shinkansen system has a proven safety record with over 50 years of service without a single passenger-related injury or fatality. Both TCRR and FRA believe that the integration of the whole Tokaido Shinkansen system is needed to ensure the historical safety record is maintained on TCRR. For example, if TCRR allowed MOW workers to perform maintenance during revenue service,

there is a potential that the MOW workers could be injured or killed. By not allowing the MOW workers to perform maintenance during revenue service, JRC removed the risk potential entirely. Any deviation from the Tokaido Shinkansen system, as it is implemented in Japan, could result in a decrease in the overall safety of the system.

#### B. Regulatory Flexibility Act and Executive Order 13272

The Regulatory Flexibility Act of 1980 (5 U.S.C. 601 *et seq.*) and Executive Order 13272 (67 FR 53461, Aug. 16, 2002) require agency review of proposed and final rules to assess their impacts on small entities. An agency must prepare an Initial Regulatory Flexibility Analysis (IRFA) unless it determines and certifies that a rule, if promulgated, would not have a significant economic impact on a substantial number of small entities. As discussed below, FRA does not believe this proposed rule would have a significant economic impact on a substantial number of small entities. However, FRA is requesting comments on whether the proposed rule would impact small entities. Therefore, FRA is publishing this IRFA to aid the public in commenting on the potential small business impacts of the requirements in this NPRM. FRA invites all interested parties to submit data and information regarding the potential economic impact on small entities that would result from the adoption of the proposals in this NPRM. FRA will consider all information, including comments received in the public comment process, to determine whether the rule will have a significant economic impact on small entities.

#### 1. Reasons FRA Is Considering the Proposed Rule

The proposed rule takes a systems-approach to safety, and so includes standards that address all aspects of the TCRR high-speed system, including signal and trainset control, track safety, rolling stock, operating rules and practices, system qualification tests, and personnel qualifications. In addition, the proposed rule would make applicable certain FRA regulations that apply to all railroads, which are appropriate for application to TCRR, such as alcohol and drug standards, hours of service requirements, and locomotive engineer and conductor certification. Consistent with its statement in the most recent Passenger Equipment Safety Standards final rule, published November 21, 2018 (83 FR 59182), FRA proposes to regulate the TCRR system as a standalone system.

<sup>10</sup> Note that FRA has not made any determination regarding the potential financial viability of the TCRR proposal, even under the terms of this NPRM.

<sup>11</sup> On average, waivers would need to be renewed every 5 years; however, given the complexity of the TCRR system it is unknown if those waivers would need to be renewed more often.

<sup>12</sup> Waivers are designed to provide relief from a specific regulatory provision and not to provide regulatory oversight for an entire railroad system.

## 2. Objectives and the Legal Basis for the Proposed Rule

The Federal railroad statutes apply to all railroads, as defined in 49 U.S.C. 20102, including the TCRR system proposed to be built in Texas.

## 3. Description and Estimate of the Number of Small Entities Affected

The Regulatory Flexibility Act of 1980 (5 U.S.C. 601 *et seq.*) requires a review of proposed and final rules to assess their impact on small entities, unless the Secretary certifies that the rule would not have a significant economic impact on a substantial number of small entities. “Small entity” is defined in 5 U.S.C. 601 as a small business concern that is independently owned and operated, and is not dominant in its field of operation. The U.S. Small Business Administration (SBA) has authority to regulate issues related to small businesses, and stipulates in its size standards that a “small entity” in the railroad industry is a for profit “line-haul railroad” that has fewer than 1,500 employees, a “short line railroad” with fewer than 500 employees, or a “commuter rail system” with annual receipts of less than seven million dollars. *See* “Size Eligibility Provisions and Standards,” 13 CFR part 121, subpart A. Additionally, section 601(5) of the Small Business Act defines “small entities” as governments of cities, counties, towns, townships, villages, school districts, or special districts with populations less than 50,000 that operate railroads.

Federal agencies may adopt their own size standards for small entities in consultation with SBA and in conjunction with public comment. Thus, in consultation with SBA, FRA has published a final statement of agency policy that formally establishes “small entities” or “small businesses” as railroads, contractors and shippers that meet the revenue requirements of a Class III railroad<sup>13</sup>—\$20 million or less in inflation-adjusted annual revenue—and commuter railroads or small government jurisdictions that serve populations of 50,000 or less.<sup>14</sup>

The “universe” of entities this NPRM would affect includes only those small entities that can reasonably be expected to be directly affected by the provisions of this rule. In this case, the “universe” consists of a single railroad, TCRR. For the purposes of this analysis, TCRR is not considered a small entity, as it is considered to be a passenger railroad, and therefore doesn’t meet any of the

above definitions of a “small entity” or a “small business.”

FRA requests comments about the impact that the proposed regulation would have on TCRR.

## 4. Description and Estimate of Compliance Requirements Including Differences in Cost, if Any, for Different Groups of Small Entities

As TCRR is not considered a small entity and, furthermore, is the only entity being regulated through the proposed regulation, there are no compliance requirements that would impact any small entities.

## 5. Identification of Relevant Federal Rules That May Duplicate, Overlap, or Conflict With the Proposed Rule

The proposed rule takes a systems-approach, and so includes standards that address all aspects of the TCRR high-speed system signal and trainset control, track safety, rolling stock, operating rules and practices, system qualification tests, and personnel qualifications. In addition, the proposed rule would make applicable certain existing FRA regulations that apply to all railroads, which are appropriate for application to TCRR, such as alcohol and drug standards, hours of service requirements, and locomotive engineer and conductor certification. No new regulations are being created with the proposed rule but rather, the thresholds of specific general rules of applicability that apply to all railroads are being modified to accommodate the unique Tokaido Shinkansen high-speed rail system.

As no new regulations are being created with the proposed rule, FRA doesn’t believe there is any overlap or conflict with any rules and regulations. FRA requests comments regarding any overlap or conflict with other rules and regulations that might result from the proposed rule.

## 6. Significant Regulatory Alternatives

FRA has a regulatory program in place, pursuant to its statutory authority, to address equipment, track, operating practices, and human factors in the existing, conventional railroad environment. However, significant operational and equipment differences exist between the system proposed for Texas and existing passenger operations in the United States. In many of the railroad safety disciplines, FRA’s current regulations do not adequately address the safety concerns and operational characteristics of the proposed TCRR system. Therefore, to assure the public that this new system will operate safely, minimum Federal

safety standards must be in place when TCRR commences operations.

Furthermore, as TCRR is not considered a small entity and is the only entity being regulated through the proposed rule, there is no economic impact to a small entity for which an alternative regulatory approach is needed in order to minimize the potential impact to small entities.

FRA invites all interested parties to submit data and information regarding the potential economic impact that would result from adoption of the proposals in this NPRM. FRA will consider all comments received in the public comment process when making a determination.

### C. Paperwork Reduction Act

In accordance with the Paperwork Reduction Act of 1995, 44 U.S.C 3501–3520, and its implementing regulations, 5 CFR part 1320, when information collection requirements pertain to nine or fewer entities, Office of Management and Budget (OMB) approval of the collection requirements is not required. This regulation pertains to one railroad, and therefore, OMB approval of the paperwork collection requirements in this proposed rule is not required.

### D. Federalism Implications

E.O. 13132, “Federalism” (64 FR 43255, Aug. 10, 1999), requires FRA to develop an accountable process to ensure “meaningful and timely input by State and local officials in the development of regulatory policies that have federalism implications.” “Policies that have federalism implications” are defined in the Executive Order to include regulations that have “substantial direct effects on the States, on the relationship between the national government and the States, or on the distribution of power and responsibilities among the various levels of government.” Under E.O. 13132, the agency may not issue a regulation with federalism implications that imposes substantial direct compliance costs and that is not required by statute, unless the Federal Government provides the funds necessary to pay the direct compliance costs incurred by State and local governments, or the agency consults with State and local government officials early in the process of developing the regulation. Where a regulation has federalism implications and preempts State law, the agency seeks to consult with State and local officials in the process of developing the regulation.

This proposed rule has been analyzed under the principles and criteria

<sup>13</sup> See 49 CFR 1201.1

<sup>14</sup> See 68 FR 24891 (May 9, 2003) (codified at appendix C to 49 CFR part 209).

contained in E.O. 13132. This proposed rule will not have a substantial effect on the States or their political subdivisions, and it will not affect the relationships between the Federal Government and the States or their political subdivisions, or the distribution of power and responsibilities among the various levels of government. In addition, FRA has determined that this regulatory action will not impose substantial direct compliance costs on the States or their political subdivisions. Therefore, the consultation and funding requirements of E.O. 13132 do not apply.

However, the final rule arising from this rulemaking could have preemptive effect by operation of law under certain provisions of the Federal railroad safety statutes, specifically the former Federal Railroad Safety Act of 1970, repealed and recodified at 49 U.S.C. 20106, and the former Locomotive Boiler Inspection Act (LIA) at 45 U.S.C. 22–34, repealed and re-codified at 49 U.S.C. 20701–20703. Section 20106 provides that States may not adopt or continue in effect any law, regulation, or order related to railroad safety or security that covers the subject matter of a regulation prescribed or order issued by the Secretary of Transportation (with respect to railroad safety matters) or the Secretary of Homeland Security (with respect to railroad security matters), except when the State law, regulation, or order qualifies under the “essentially local safety or security hazard” exception to section 20106. Moreover, the former LIA has been interpreted by the Supreme Court as preempting the field concerning locomotive safety. *See Napier v. Atlantic Coast Line R.R.*, 272 U.S. 605 (1926).

#### *E. International Trade Impact Assessment*

The Trade Agreements Act of 1979 (Pub. L. 96–39, 19 U.S.C. 2501 *et seq.*) prohibits Federal agencies from engaging in any standards or related activities that create unnecessary obstacles to the foreign commerce of the United States. Legitimate domestic objectives, such as safety, are not considered unnecessary obstacles. The statute also requires consideration of international standards and, where appropriate, that they be the basis for U.S. standards.

FRA has assessed the potential effect of this proposed rulemaking on foreign commerce and believes that its proposed requirements are consistent with the Trade Agreements Act. The requirements are safety standards, which, as noted, are not considered unnecessary obstacles to trade.

#### *F. Environmental Impact*

FRA is evaluating the potential environmental impacts that may result from this proposed rule in accordance with the National Environmental Policy Act (NEPA; 42 U.S.C. 4321 *et seq.*), other environmental statutes, related regulatory requirements, and its “Procedures for Considering Environmental Impacts” (FRA’s Procedures) (64 FR 28545, May 26, 1999). FRA released a draft environmental impact statement (EIS) for public comment on December 22, 2017. The public comment period on the draft EIS closed on March 9, 2018. FRA is addressing public comments received on the draft EIS and conducting additional environmental analysis as needed to inform its preparation of the final EIS. FRA must issue the final EIS and its record of decision before issuing the final rule establishing an alternative regulatory framework for safety oversight of the system proposed by TCRR. The draft EIS is available on FRA’s website at <https://www.fra.dot.gov/Page/P0700>. FRA will provide notice of publication of the final EIS to the public in the **Federal Register**, through the Environmental Protection Agency’s weekly Notice of Availability, and on its website at the above web address.

#### *G. Executive Order 12898 (Environmental Justice)*

E.O. 12898, “Federal Actions to Address Environmental Justice in Minority Populations and Low-Income Populations,” and DOT Order 5610.2(a) (91 FR 27534, May 10, 2012) require DOT agencies to achieve environmental justice as part of their mission by identifying and addressing, as appropriate, disproportionately high and adverse human health or environmental effects, including interrelated social and economic effects, of their programs, policies, and activities on minority populations and low-income populations. The DOT Order instructs DOT agencies to address compliance with E.O. 12898 and requirements within the DOT Order in rulemaking activities, as appropriate. FRA has evaluated this proposed rule under E.O. 12898 and the DOT Order and has determined that it will not cause disproportionately high and adverse human health and environmental effects on minority populations or low-income populations.

#### *H. Executive Order 13175 (Tribal Consultation)*

FRA has evaluated this proposed rule in accordance with the principles and

criteria contained in E.O. 13175, “Consultation and Coordination with Indian Tribal Governments,” dated November 6, 2000. This proposed rule will not have a substantial direct effect on one or more Indian tribes, will not impose substantial direct compliance costs on Indian tribal governments, and will not preempt tribal laws. Therefore, the funding and consultation requirements of E.O. 13175 do not apply, and a tribal summary impact statement is not required.

#### *I. Unfunded Mandates Reform Act of 1995*

Under section 201 of the Unfunded Mandates Reform Act of 1995 (Pub. L. 104–4, 2 U.S.C. 1531), each Federal agency “shall, unless otherwise prohibited by law, assess the effects of Federal regulatory actions on State, local, and tribal governments, and the private sector (other than to the extent that such regulations incorporate requirements specifically set forth in law).” Section 202 of the Act (2 U.S.C. 1532) further requires that “before promulgating any general notice of proposed rulemaking that is likely to result in the promulgation of any rule that includes any Federal mandate that may result in expenditure by State, local, and tribal governments, in the aggregate, or by the private sector, of \$100,000,000 or more (adjusted annually for inflation) in any 1 year, and before promulgating any final rule for which a general notice of proposed rulemaking was published, the agency shall prepare a written statement” detailing the effect on State, local, and tribal governments and the private sector. This proposed rule will not result in the expenditure, in the aggregate, of \$100,000,000 or more (as adjusted annually for inflation) in any one year, and thus preparation of such a statement is not required.

#### *J. Energy Impact*

E.O. 13211, “Actions Concerning Regulations That Significantly Affect Energy Supply, Distribution, or Use,” requires Federal agencies to prepare a Statement of Energy Effects for any “significant energy action.” *See* 66 FR 28355, May 22, 2001. FRA has evaluated this proposed rule in accordance with E.O. 13211 and determined that this regulatory action is not a “significant energy action” within the meaning of the E.O.

E.O. 13783, “Promoting Energy Independence and Economic Growth,” requires Federal agencies to review regulations to determine whether they potentially burden the development or use of domestically produced energy

resources, with particular attention to oil, natural gas, coal, and nuclear energy resources. See 82 FR 16093, March 31, 2017. FRA has determined this regulatory action will not burden the development or use of domestically produced energy resources.

#### *K. Privacy Act Statement*

In accordance with 5 U.S.C. 553(c), DOT solicits comments from the public to better inform its rulemaking process. DOT posts these comments, without edit, to *www.regulations.gov*, as described in the system of records notice, DOT/ALL-14 FDMS, accessible through *www.dot.gov/privacy*. To facilitate comment tracking and response, we encourage commenters to provide their name, or the name of their organization; however, submission of names is completely optional. Whether commenters identify themselves, all timely comments will be fully considered. If you wish to provide comments containing proprietary or confidential information, please contact the agency for alternate submission instructions.

#### **List of Subjects**

High-speed rail, Incorporation by reference, Railroad safety, Reporting and recordkeeping requirements, Rule of particular applicability, Tokaido Shinkansen.

#### **The Proposed Rule**

For the reasons discussed in the preamble, FRA proposes to add part 299 to chapter II, subtitle B of title 49, Code of Federal Regulations as follows:

1. Part 299 is added to read as follows:

### **PART 299—TEXAS CENTRAL RAILROAD HIGH-SPEED RAIL SAFETY STANDARDS**

#### **Subpart A—General Requirements**

Sec.

- 299.1 Purpose and scope.
- 299.3 Applicability.
- 299.5 Definitions.
- 299.7 Responsibility for compliance.
- 299.9 Notifications and filings.
- 299.11 Electronic recordkeeping.
- 299.13 System description.
- 299.15 Special approvals.
- 299.17 Incorporation by reference.

#### **Subpart B—Signal and Trainset Control System**

- 299.201 Technical PTC system requirements.
- 299.203 PTC system required.
- 299.205 PTC System Certification.
- 299.207 PTC Safety Plan content requirements.
- 299.209 PTC system use and failures.
- 299.211 Communications and security requirements.
- 299.213 Records retention.

- 299.215 Operations and Maintenance Manual.

#### **Subpart C—Track Safety Standards**

- 299.301 Restoration or renewal of track under traffic conditions.
- 299.303 Measuring track not under load.
- 299.305 Drainage.
- 299.307 Vegetation.
- 299.309 Classes of track: operating speed limits.
- 299.311 Track geometry; general.
- 299.313 Track geometry; performance based.
- 299.315 Curves; elevations and speed limitations.
- 299.317 Track strength.
- 299.319 Track fixation and support.
- 299.321 Defective rails.
- 299.323 Continuous welded rail (CWR) plan.
- 299.325 Continuous welded rail (CWR); general.
- 299.327 Rail end mismatch.
- 299.329 Rail joints and torch cut rails.
- 299.331 Turnouts and crossings generally.
- 299.333 Frog guard rails and guard faces; gauge.
- 299.335 Derails.
- 299.337 Automated vehicle-based inspection systems.
- 299.339 Daily sweeper inspection.
- 299.341 Inspection of rail in service.
- 299.343 Initial inspection of new rail and welds.
- 299.345 Visual inspections; right-of-way.
- 299.347 Special inspections.
- 299.349 Inspection records.
- 299.351 Qualifications for track maintenance and inspection personnel.
- 299.353 Personnel qualified to supervise track restoration and renewal.
- 299.355 Personnel qualified to inspect track.
- 299.357 Personnel qualified to inspect and restore continuous welded rail.

#### **Subpart D—Rolling Stock**

- 299.401 Clearance requirements.
- 299.403 Trainset structure.
- 299.405 Trainset interiors.
- 299.407 Glazing.
- 299.409 Brake system.
- 299.411 Bogies and suspension system.
- 299.413 Fire safety.
- 299.415 Doors.
- 299.417 Emergency lighting.
- 299.419 Emergency communication.
- 299.421 Emergency roof access.
- 299.423 Markings and instructions for emergency egress and rescue access.
- 299.425 Low-location emergency exit path marking.
- 299.427 Emergency egress windows.
- 299.429 Rescue access windows.
- 299.431 Driver's controls and cab layout.
- 299.433 Exterior lights.
- 299.435 Electrical system design.
- 299.437 Automated monitoring.
- 299.439 Event recorders.
- 299.441 Trainset electronic hardware and software safety.
- 299.443 Safety appliances.
- 299.445 Trainset inspection, testing, and maintenance requirements.
- 299.447 Movement of defective equipment.

#### **Subpart E—Operating Rules**

- 299.501 Purpose.
- 299.503 Operating rules; filing and recordkeeping.
- 299.505 Programs of operational tests and inspections; recordkeeping.
- 299.507 Program of instruction on operating rules; recordkeeping.

#### **Subpart F—System Qualification Tests**

- 299.601 Responsibility for verification demonstrations and tests.
- 299.603 Preparation of system-wide qualification test plan.
- 299.605 Functional and performance qualification tests.
- 299.607 Pre-revenue service systems integration testing.
- 299.609 Vehicle/track system qualification.
- 299.611 Simulated revenue operations.
- 299.613 Verification of compliance.

#### **Subpart G—Inspection, Testing, and Maintenance Program**

- 299.701 General requirements.
- 299.703 Compliance.
- 299.705 Standard procedures for safely performing inspection, testing, and maintenance, or repairs.
- 299.707 Maintenance intervals.
- 299.709 Quality control program.
- 299.711 Inspection, testing, and maintenance program format.
- 299.713 Program approval procedures.

#### **Appendix A to Part 299—Criteria for Certification of Crashworthy Event Recorder Memory Module**

#### **Appendix B to Part 299—Cab Noise Test Protocol**

**Authority:** 49 U.S.C. 20103, 20107, 20133, 20141, 20302–20303, 20306, 20701–20702, 21301–21302, 21304; 28 U.S.C. 2461, note; and 49 CFR 1.89.

#### **Subpart A—General Requirements**

##### **§ 299.1 Purpose and scope.**

This part prescribes minimum Federal safety standards for the high-speed transportation system described in detail in § 299.13, known as Texas Central Railroad, LLC and hereinafter referred to as the “railroad.” The purpose of this part is to prevent accidents, casualties, and property damage which could result from operation of this system.

##### **§ 299.3 Applicability.**

(a) This part applies only to the railroad, as described in § 299.13.

(b) Except as stated in paragraph (c) of this section, this part, rather than the generally applicable Federal railroad safety regulations, shall apply to the railroad.

(c) The following Federal railroad safety regulations found in Title 49 of the Code of Federal Regulations, and any amendments are applicable to the railroad.

- (1) Part 207, Railroad Police Officers;



(2) Part 209, Railroad Safety Enforcement Procedures;

(3) Part 210, Railroad Noise Emission Compliance Regulations;

(4) Part 211, Rules of Practice;

(5) Part 212, State Safety Participation Regulations;

(6) Part 214, Railroad Workplace Safety, except § 214.339;

(7) Part 216, Special Notice and Emergency Order Procedures;

(8) Part 218, Railroad Operating Practices;

(9) Part 219, Control of Alcohol and Drug Use;

(10) Part 220, Radio Standards and Procedures;

(11) Part 225, Railroad Accidents/ Incidents: Reports, Classification, and Investigations;

(12) Part 227, Occupational Noise Exposure except § 227.119(c)(10) and (11) with respect to the railroad's high-speed trainsets only, which shall comply with 299.431(k) and (l);

(13) Part 228, Hours of Service of Railroad Employees;

(14) Part 233, Signal Systems Reporting Requirements;

(15) Part 235, Instructions Governing Applications for Approval of a Discontinuance or Material Modification of a Signal System or Relief from the Requirements of Part 236, except § 235.7;

(16) Part 236, Installation, Inspection, Maintenance and Repair of Signal and Train Control System, Devices, and Appliances, subparts A through G, as excepted by the railroad's PTC Safety Plan (PTCSP) under § 299.201(d);

(17) Part 237, Railroad Bridge Safety Standards;

(18) Part 239, Passenger Train Emergency Preparedness;

(19) Part 240, Qualification and Certification of Locomotive Engineers;

(20) Part 242, Qualification and Certification of Train Conductors;

(21) Part 243, Training, Qualification, and Oversight for Safety-Related Railroad Employees;

(22) Part 270, System Safety Program

(23) Part 272, Critical Incident Stress Plans; and

(24) The following parts shall apply to the railroad's maintenance-of-way equipment as it is used in work trains, rescue operations, yard movements, and other non-passenger functions:

(i) Part 215, Railroad Freight Car Safety Standards;

(ii) Part 223 Glazing Standards;

(iii) Part 229, Railroad Locomotive Safety Standards, except—

(A) Section 229.71. Instead, the railroad's maintenance-of-way equipment shall comply with § 299.401(b), except for the sweeper

vehicle, which shall have a clearance above top of rail no less than 35 mm (1.77 inches).

(B) Section 229.73. Instead, the railroad's maintenance-of-way equipment shall be designed so as to be compatible with the railroad's track structure under subpart C of this part.

(iv) Part 231, Railroad Safety Appliance Standards; and,

(v) Part 232, Railroad Power Brakes and Drawbars.

(d) The Federal railroad safety statutes apply to all railroads, as defined in 49 U.S.C. 20102. The railroad covered by this part is a railroad under that definition. Therefore, the Federal railroad safety statutes, Subtitle V of Title 49 of the United States Code, apply directly to the railroad. However, pursuant to authority granted under 49 U.S.C. 20306, FRA has exempted the railroad from certain requirements of 49 U.S.C. ch. 203.

#### § 299.5 Definitions.

As used in this part—

*Absolute block* means a block of track circuits in which no trainset is permitted to enter while occupied by another trainset.

*Adjusting/de-stressing* means the procedure by which a rail's neutral temperature is readjusted to the desired value. It typically consists of cutting the rail and removing rail anchoring devices, which provides for the necessary expansion and contraction, and then re-assembling the track.

*Administrator* means the Administrator of the FRA or the Administrator's delegate.

*Associate Administrator* means FRA's Associate Administrator for Safety and Chief Safety Officer, or that person's delegate.

*Automatic train control (ATC)* means the signaling system, composed of ground and on-board equipment. The on-board equipment continually receives a signal from the ground equipment. ATC on-board equipment controls the trainset speed to prevent train-to-train collisions and overspeed derailments.

*ATC cut-out mode* means the mode of ATC on-board equipment used for emergency operations to disable the ATC on-board equipment on the trainset.

*ATC main line mode* means the mode of ATC on-board equipment which controls trainset speed on mainlines.

*ATC overrun protection* means an overlay of the ATC shunting mode to prevent overrun at the end of a track.

*ATC shunting mode* means the mode of ATC on-board equipment which restricts the trainsets maximum speed to 30 km/h (19 mph).

*Brake, air* means a combination of devices operated by compressed air, arranged in a system and controlled electrically or pneumatically, by means of which the motion of a train or trainset is retarded or arrested.

*Brake, disc* means a retardation system used on the passenger trainsets that utilizes flat discs as the braking surface.

*Brake, electric* means a trainset braking system in which the kinetic energy of a moving trainset is used to generate electric current at the traction motors, which is then returned into the catenary system.

*Brake, emergency application* means a brake application initiated by a de-energized brake command and is retrievable when there is no malfunction that initiates an automatic emergency brake application. An emergency brake application can be initiated by the driver or automatically by ATC. An emergency brake application, as defined here, is equivalent to a full-service brake application in the U.S.

*Brake, urgent application* means an irretrievable brake application designed to minimize the braking distance. An urgent brake application, as defined here, is the equivalent of an emergency brake application in the U.S.

*Bogie* means an assembly that supports the weight of the carbody and which incorporates the suspension, wheels and axles, traction motors and friction brake components. Each unit of a trainset is equipped with two bogies. In the U.S. a bogie is commonly referred to as a truck.

*Broken rail* means a partial or complete separation of an otherwise continuous section of running rail, excluding rail joints, expansion joints, and insulated joints.

*Buckling incident/buckling rail* means the formation of a lateral misalignment caused by high longitudinal compressive forces in a rail sufficient in magnitude to exceed the track geometry alignment safety limits defined in § 299.309.

*Buckling-prone condition* means a track condition that can result in the track being laterally displaced due to high compressive forces caused by critical rail temperature combined with insufficient track strength and/or train dynamics.

*Cab* means the compartment or space within a trainset that is designed to be occupied by a driver and contain an operating console for exercising control over the trainset.

*Cab car* means a rail vehicle at the leading or trailing end, or both, of a trainset which has a driver's cab and is

intended to carry passengers, baggage, or mail. A cab car may or may not have propelling motors.

*Cab end structure* means the main support projecting upward from the underframe at the cab end of a trainset.

*Cab signal* means a signal located in the driver's compartment or cab, indicating a condition affecting the movement of a trainset.

*Calendar day* means a time period running from one midnight to the next midnight on a given date.

*Cant deficiency* means the additional height, which if added to the outer rail in a curve, at the designated vehicle speed, would provide a single resultant force, due to the combined effects of weight and centrifugal force on the vehicle, having a direction perpendicular to the plane of the track.

*Continuous welded rail (CWR)* means rail that has been welded together into lengths exceeding 122 m (400 feet). Rail installed as CWR remains CWR, regardless of whether a joint is installed into the rail at a later time.

*Consist, fixed* means a semi-permanently coupled trainset that is arranged with each unit in a specific location and orientation within the trainset.

*Core system, high-speed* means the safety-critical systems, sub-systems, and procedures required for a high-speed system operation that assures a safe operation as required within this part.

*Crewmember* means a railroad employee called to perform service covered by 49 U.S.C. 21103.

*Critical buckling stress* means the minimum stress necessary to initiate buckling of a structural member.

*Desired rail installation temperature range* means the rail temperature range in a specific geographical area, at which forces in CWR installed in that temperature range should not cause a track buckle in extreme heat, or a pull-apart during extreme cold weather.

*Disturbed track* means the disturbance of the roadbed or ballast section, as a result of track maintenance or any other event, which reduces the lateral or longitudinal resistance of the track, or both.

*Driver* means any person who controls the movement of a trainset(s) from the cab, and is required to be certified under 49 CFR part 240. A driver, as used in this part, is equivalent to a locomotive engineer.

*Employee or railroad employee* means an individual who is engaged or compensated by the railroad or by a contractor to the railroad to perform any of the duties defined in this part.

*Event recorder* means a device, designed to resist tampering, that

monitors and records data, as detailed in §§ 299.439 and 236.1005(d) of this chapter, over the most recent 48 hours of operation of the trainset.

*Expansion joint* means a piece of special trackwork designed to absorb heat-induced expansion and contraction of the rails.

*General control center* means the location where the general control center staff work.

*General control center staff* means qualified individuals located in the general control center who are responsible for the safe operation of the railroad's high-speed passenger rail system. The duties of individuals who work at the general control center include: Trainset movement control, crew logistic management, signaling, passenger services, rolling stock logistic management, and right-of-way maintenance management.

*Glazing, end-facing* means any exterior glazing installed in a trainset cab located where a line perpendicular to the exterior surface glazing material makes horizontal angle of 50 degrees or less with the longitudinal center line of the rail vehicle in which the panel is installed. A glazing panel that curves so as to meet the definition for both side-facing and end-facing glazing is end-facing glazing.

*Glazing, exterior* means a glazing panel that is an integral part of the exterior skin of a rail vehicle with a surface exposed to the outside environment.

*Glazing, side-facing* means any glazing located where a line perpendicular to the exterior surface of the panel makes an angle of more than 50 degrees with the longitudinal center line of the rail vehicle in which the panel is installed.

*High voltage* means an electrical potential of more than 150 volts.

*In passenger service/in revenue service* means a trainset that is carrying, or available to carry, passengers. Passengers need not have paid a fare in order for the trainset to be considered in passenger or in revenue service.

*In service* means, when used in connection with trainset, a trainset subject to this part that is in revenue service, unless the equipment—

- (1) Is being handled in accordance with § 299.447, as applicable;
- (2) Is in a repair shop or on a repair track; or
- (3) Is on a storage track and is not carrying passengers.

*Insulated joint, glued* means a rail joint located at the end of a track circuit designed to insulate electrical current from the signal system in the rail.

*Interior fitting* means any component in the passenger compartment which is mounted to the floor, ceiling, sidewalls, or end walls and projects into the passenger compartment more than 25 mm (1 in.) from the surface or surfaces to which it is mounted. Interior fittings do not include side and end walls, floors, door pockets, or ceiling lining materials, for example.

*Intermediate car* means a passenger car or unit of a trainset located between cab cars which may or may not have propelling motors.

*L/V ratio* means the ratio of the lateral force that any wheel exerts on an individual rail to the vertical force exerted by the same wheel on the rail.

*Lateral* means the horizontal direction perpendicular to the direction of travel.

*Locomotive* means a piece of on-track rail equipment, other than hi-rail, specialized maintenance, or other similar equipment, which may consist of one or more units operated from a single control stand with one or more propelling motors designed for moving other passenger equipment; with one or more propelling motors designed to transport freight or passenger traffic, or both; or without propelling motors but with one or more control stands.

*Longitudinal* means in a direction parallel to the direction of travel of a rail vehicle.

*Marking/delineator* means a visible notice, sign, symbol, line or trace.

*N700* means the N700 series trainset currently in, or future variants approved for, use on JRC's Tokaido Shinkansen system.

*Occupied volume* means the volume of a passenger car or a unit in a trainset where passengers or crewmembers are normally located during service operation, such as the cab and passenger seating areas. The entire width of a vehicle's end compartment that contains a control stand is an occupied volume. A vestibule is typically not considered occupied.

*On-board attendant* means a qualified individual on a trainset that is responsible for coordination with a station platform attendant to assure safety during passenger boarding and alighting within a station. An on-board attendant, as used in this part, is equivalent to a passenger conductor.

*Override* means to climb over the normal coupling or side buffers and linking mechanism and impact the end of the adjoining rail vehicle or unit above the underframe.

*Overrun protection coil* means track circuit cables placed short of turnouts, or crossovers within stations and trainset maintenance facilities to prevent unauthorized route access.

*Passenger car* means a unit of a trainset intended to provide transportation for members of the general public. A cab car and an intermediate car are considered passenger cars.

*Passenger compartment* means an area of a passenger car that consists of a seating area and any vestibule that is connected to the seating area by and open passageway.

*Passenger equipment* means the N700 series trainset currently in, or future variants approved for, use on the on JRC's Tokaido Shinkansen system, or any unit thereof.

*Permanent deformation* means the undergoing of a permanent change in shape of a structural member of a rail vehicle.

*PTC* means positive train control as further described in § 299.201.

*Qualified individual* means a person that has successfully completed all instruction, training, and examination programs required by both the employer and this part, and that the person, therefore, may reasonably be expected to proficiently perform his or her duties in compliance with all Federal railroad safety laws, regulations, and orders.

*Rail neutral temperature* is the temperature at which the rail is neither in compression nor tension.

*Rail temperature* means the temperature of the rail, measured with a rail thermometer.

*Rail vehicle* means railroad rolling stock, including, but not limited to passenger and maintenance vehicles.

*Railroad equipment* means all trains, trainsets, rail cars, locomotives, and on-track maintenance vehicles owned or used by the railroad.

*Railroad*, the means the company, also known as the Texas Central Railroad, LLC, which is the entity that will operate and maintain the high-speed rail system initially connecting Dallas to Houston, Texas, and is responsible for compliance with all aspects of this rule.

*Repair point* means a location designated by the railroad where repairs of the type necessary occur on a regular basis. A repair point has, or should have, the facilities, tools, and personnel qualified to make the necessary repairs. A repair point need not be staffed continuously.

*Representative car/area* means a car/area that shares the relevant characteristics as the car(s)/area(s) it represents (*i.e.*, same signage/markings layout, and charging light system for passive systems or light fixtures and power system for electrically powered systems).

*Rollover strength* means the strength provided to protect the structural integrity of a rail vehicle in the event the vehicle leaves the track and impacts the ground on its side or roof.

*Safety appliance* means an appliance, required under 49 U.S.C. ch. 203, excluding power brakes. The term includes automatic couplers, handbrakes, crew steps, handholds, handrails, or ladder treads made of steel or a material of equal or greater mechanical strength used by the traveling public or railroad employees that provides a means for safe coupling, uncoupling, or ascending or descending passenger equipment.

*Safety-critical* means a component, system, software, or task that, if not available, defective, not functioning, not functioning correctly, not performed, or not performed correctly, increases the risk of damage to railroad equipment or injury to a passenger, railroad employee, or other person.

*Search, valid* means a continuous inspection for internal rail defects where the equipment performs as intended and equipment responses are interpreted by a qualified individual as defined in subpart C.

*Semi-permanently coupled* means coupled by means of a drawbar or other coupling mechanism that requires tools to perform the coupling or uncoupling operation. Coupling and uncoupling of each semi-permanently coupled unit in a trainset can be performed safely only while at a trainset maintenance facility where personnel can safely get under a unit or between units, or other location under the protections of subpart B of part 218 of this chapter.

*Side sill* means that portion of the underframe or side at the bottom of the rail vehicle side wall.

*Shinkansen, Tokaido* means the high-speed rail system operated by the Central Japan Railway Company between Tokyo and Shin-Osaka, Japan, that is fully dedicated and grade separated.

*Slab track* means railroad track structure in which the rails are attached to and supported by a bed or slab, usually of concrete (or asphalt), which acts to transfer the load and provide track stability.

*Spall, glazing* means small pieces of glazing that fly off the back surface of the glazing when an object strikes the front surface.

*Speed, maximum approved* means the maximum trainset speed approved by FRA based upon the qualification tests conducted under § 299.609(g).

*Speed, maximum authorized* means the speed at which trainsets are permitted to travel safely, as determined

by all operating conditions and signal indications.

*Speed, maximum safe operating* means the highest speed at which trainset braking may occur without thermal damage to the discs.

*Station platform attendant* means a qualified individual positioned on the station platform in close proximity to the train protection switches while a trainset is approaching and departing a station, and is responsible for coordination with an on-board attendant to assure safety during passenger boarding and alighting within a station.

*Superelevation* means the actual elevation of the outside rail above the inside rail.

*Sweeper vehicle* means a rail vehicle whose function is to detect obstacles within the static construction gauge prior to the start of daily revenue service.

*Tight track* means CWR which is in a considerable amount of compression.

*Track acceleration measurement system (TAMS)* means an on-track, vehicle-borne technology used to measure lateral and vertical carbody accelerations.

*Track geometry measurement system (TGMS)* means an on-track, vehicle-borne technology used to measure track surface, twist, crosslevel, alignment, and gauge.

*Track lateral resistance* means the resistance provided to the rail/crosstie structure against lateral displacement.

*Track longitudinal resistance* means the resistance provided by the rail anchors/rail fasteners and the ballast section to the rail/crosstie structure against longitudinal displacement.

*Track, non-ballasted* means a track structure not supported by ballast in which the rails are directly supported by concrete or steel structures. Non-ballasted track can include slab track and track structures where the rails are directly fixed to steel bridges or to servicing pits within trainset maintenance facilities.

*Train* means a trainset, or locomotive or locomotive units coupled with or without cars.

*Train-induced forces* means the vertical, longitudinal, and lateral dynamic forces which are generated during train movement and which can contribute to the buckling potential of the rail.

*Train protection switch* means a safety device located on station platforms and on safe walkways along the right-of-way. The train protection switch is tied directly into the ATC system and is used in the event that trainsets in the immediate area must be stopped.

*Trainset* means a passenger train including the cab cars and intermediate cars that are semi-permanently coupled to operate as a single consist. The individual units of a trainset are uncoupled only for emergencies or maintenance conducted in repair facilities.

*Trainset maintenance facility* means a location equipped with the special tools, equipment, and qualified individuals capable of conducting pre-service inspections and regular inspections on the trainsets in accordance with the railroad's inspection, testing, and maintenance program. Trainset maintenance facilities are also considered repair points.

*Transponder* means a wayside component of the ATC system used to provide trainset position correction on the mainline or to provide an overlay of overrun protection within a trainset maintenance facility.

*Underframe* means the lower horizontal support structure of a rail vehicle.

*Unit, trainset* means a cab car or intermediate car of a trainset.

*Vestibule* means an area of a passenger car that normally does not contain seating, is located adjacent to a side exit door, and is used in passing from a seating area to a side exit door.

*Yard* means a system of tracks within defined limits and outside of the territory controlled by signals, which can be used for the making up of non-passenger trains or the storing of maintenance-of-way equipment.

*Yield strength* means the ability of a structural member to resist a change in length caused by an applied load. Exceeding the yield strength will cause permanent deformation of the member.

#### **§ 299.7 Responsibility for compliance.**

- (a) The railroad shall not—
- (1) Use, haul, or permit to be used or hauled on its line(s) any trainset—
    - (i) With one or more defects not in compliance with this part; or
    - (ii) That has not been inspected and tested as required by a provision of this part.
  - (2) Operate over any track, except as provided in paragraph (e) of this section, with one or more conditions not in compliance this part, if the railroad has actual knowledge of the facts giving rise to the violation, or a reasonable person acting in the circumstances and exercising reasonable care would have that knowledge.
  - (3) Violate any other provision of this part or any provision of the applicable FRA regulations listed under § 299.3(c).
- (b) For purposes of this rule, a trainset shall be considered in use prior to the

trainset's departure as soon as it has received, or should have received the inspection required under this part for movement and is ready for service.

(c) Although many of the requirements of this part are stated in terms of the duties of the railroad, when any person (including, but not limited to, a contractor performing safety-related tasks under contract to the railroad subject to this part) performs any function required by this part, that person (whether or not the railroad) is required to perform that function in accordance with this part.

(d) For purposes of this part, the railroad shall be responsible for compliance with all track safety provisions set forth in subpart C of this part. When the railroad and/or its assignee have actual knowledge of the facts giving rise to a violation, or a reasonable person acting in the circumstances and exercising reasonable care would have knowledge that the track does not comply with the requirements of this part, it shall—

- (1) Bring the track into compliance;
- (2) Halt operations over that track; or
- (3) Continue operations over the segment of non-complying track in accordance with the provisions of § 299.309(b) or (c).

(e) The FRA Administrator may hold the railroad, the railroad's contractor, or both responsible for compliance with the requirements of this part and subject to civil penalties.

#### **§ 299.9 Notification and filings.**

All notifications and filings to the FRA required by this part shall be submitted to the Associate Administrator for Railroad Safety and Chief Safety Officer, 1200 New Jersey Avenue SE, Washington, DC 20590, unless otherwise specified.

#### **§ 299.11 Electronic recordkeeping.**

The railroad's electronic recordkeeping shall be retained such that—

- (a) The railroad maintains an information technology security program adequate to ensure the integrity of the electronic data storage system, including the prevention of unauthorized access to the program logic or individual records;
- (b) The program and data storage system must be protected by a security system that utilizes an employee identification number and password, or a comparable method, to establish appropriate levels of program access meeting all of the following standards:
  - (1) No two individuals have the same electronic identity; and
  - (2) A record cannot be deleted or altered by any individual after the

record is certified by the employee who created the record.

(c) Any amendment to a record is either—

- (1) Electronically stored apart from the record that it amends; or
- (2) Electronically attached to the record as information without changing the original record;
- (d) Each amendment to a record uniquely identifies the person making the amendment;
- (e) The system employed by the railroad for data storage permits reasonable access and retrieval; and
- (f) Information retrieved from the system can be easily produced in a printed format which can be readily provided to FRA representatives in a timely manner and authenticated by a designated representative of the railroad as a true and accurate copy of the railroad's records if requested to do so by FRA representatives.

#### **§ 299.13 System description.**

(a) *General.* This section describes the components, operations, equipment, and systems of the railroad's high-speed rail system. The railroad shall adhere to the following general requirements:

- (1) The railroad shall not exceed the maximum trainset speed approved by FRA under § 299.609(g) while in revenue service, up to a maximum speed of 330 km/h (205 mph).
- (2) The railroad shall not transport or permit to be transported in revenue service any product that has been established to be a hazardous material pursuant to 49 CFR part 172, as amended.

(3) The railroad shall not conduct scheduled right-of-way maintenance on a section of the right-of-way prior to that section of the right-of-way being cleared of all revenue service trainsets (including any trainset repositioning moves), and proper action is taken by the general control center staff to protect incursion into established maintenance zones by revenue trainsets. Additionally, the railroad shall not commence revenue service prior to completion of the maintenance activities, that section of the right-of-way being cleared of all maintenance-of-way equipment. Further, the railroad is prohibited from commencing revenue operations until after conclusion of the daily sweeper inspection, under § 299.339, and the general control center returning the signal and trainset control system to the state required to protect revenue operations.

(b) *Right-of-way.* (1) The railroad shall operate on a completely dedicated right-of-way and shall not operate or conduct joint operations with any other freight

equipment, other than the railroad's maintenance-of-way equipment, or passenger rail equipment. Only the railroad's high-speed trainsets approved for revenue operations under this part, and any equipment required for construction, maintenance, and rescue purposes may be operated over the railroad's right-of-way.

(2) There shall be no public highway-rail grade crossings. Animal and non-railroad equipment crossings shall be accomplished by means of an underpass or overpass. Private at-grade crossings shall be for the exclusive use by the railroad and shall be limited to track Classes H0 and H1.

(3) The railroad shall develop and comply with a right-of-way barrier plan. The right-of-way barrier plan shall be maintained at the system headquarters and will be made available to FRA upon request. At a minimum, the plan will contain provisions in areas of demonstrated need for the prevention of—

- (i) Vandalism;
- (ii) Launching of objects from overhead bridges or structures onto the path of trainsets;
- (iii) Intrusion of vehicles from adjacent rights-of-way; and
- (iv) Unauthorized access to the right-of-way.

(4) The entire perimeter of the system's right-of-way, except for elevated structures such as bridges and viaducts shall be permanently fenced. Elevated structures shall be equipped with walkways and safety railing.

(5) The railroad shall install intrusion detectors in accordance with the requirements set forth in subpart C of this part.

(6) The railroad shall install rain, flood, and wind detectors in locations identified by the railroad, based on relevant criteria used by JRC to provide adequate warning of when operational restrictions are required due to adverse weather conditions. Operating restrictions shall be defined in the railroad's operating rules.

(7) Access to the right-of-way for maintenance-of-way staff shall be provided on both sides of the right-of-way in accordance with the inspection, testing, and maintenance program. This access shall be protected against entry by unauthorized persons.

(8) Provision shall be made to permit emergency personnel to access the right-of-way in accordance with the Emergency Preparedness Plan pursuant to part 239 of this chapter. This access shall be protected against entry by unauthorized persons.

(9) Throughout the length of the right-of-way, the railroad shall install

walkways located at a safe distance from the tracks at a minimum distance of 2.0 m (6.56 feet) from the field side of the outside rail for a design speed of 330 km/h (205 mph). The walkways shall be used primarily for track and right-of-way inspection, but may be used for emergency evacuation or rescue access.

(10) Access to the right-of-way by maintenance-of-way personnel shall not be allowed during revenue operations unless the access is outside the minimum safe distance defined in § 299.13(b)(9). In the event of unscheduled maintenance or repair, emergency access will be provided under specific circumstances allowed under the railroad's operating rules and the inspection, testing, and maintenance program.

(11) The railroad shall record all difficulties and special situations regarding geology, hydrology, settlement, landslide, concrete, and quality criteria that arise during construction of the right-of-way. After construction, the railroad shall monitor the stability and quality standards of structures such as bridges, viaducts, and earth structures.

(12) The railroad shall make available for review by the FRA the track layout drawings which show, at a minimum, the following information:

- (i) Length of straight sections, spirals and curves, curve radius, superelevation, superelevation variations, gradients, and vertical curve radii;
- (ii) Turnouts and crossover location, technology, and geometry;
- (iii) Maximum operating speed and allowable cant deficiencies;
- (iv) Signal boxes, Go/No-Go signals, and communication devices;
- (v) Details and arrangement of track circuitry;
- (vi) Power feeding equipment including sectionalization, and return routing;
- (vii) Location of accesses to the right-of-way; and

(viii) The railroad shall also submit the specifications for the track layout, permissible track forces, components such as rail, ballast, ties, rail fasteners, and switches.

(13) Protection devices shall be installed on all highway bridge overpasses in accordance with the right-of-way plan in paragraph (b)(3) of this section.

(14) There shall be no movable bridges in the railroad's system. Stationary rail bridges located over highways or navigable waterways shall have their foundations, piers, or other support structure appropriately

protected against the impact of road vehicles or water-borne vessels.

(15) Train protection switches shall be installed at regular intervals on both sides of the right-of-way at intervals defined by the railroad and at intervals not to exceed 60 m (197 feet) on platforms within stations. These devices shall act directly on the ATC system.

(16) The railroad shall use the design wheel and rail profiles, service-proven on the Tokaido Shinkansen system, or alternate wheel and rail profiles approved by FRA.

(c) *Railroad system safety*—(1) *Inspection, testing, and maintenance procedures and criteria.* The railroad shall develop, implement, and use a system of inspection, testing, maintenance procedures and criteria, under subpart G of this part, which are initially based on the Japanese Tokaido Shinkansen system service-proven procedures and criteria, to ensure the integrity and safe operation of the railroad's rolling stock, infrastructure, and signal and trainset control system. The railroad may, subject to FRA review and approval, implement inspection, testing, maintenance procedures and criteria, incorporating new or emerging technology, under § 299.713(d)(4).

(2) *Operating practices.* The railroad shall develop, implement, and use operating rules, which meet the standards set forth in subpart E of this part and which are based on practices and procedures proven on the Tokaido Shinkansen system to ensure the integrity and safe operation of the railroad's system. The railroad shall have station platform attendants on the platform in close proximity to the train protection switches required by paragraph (b)(15) of this section, while trainsets are approaching and departing the station. The railroad's operating rules shall require coordination between on-board crew and station platform attendants to assure safety during passenger boarding and alighting from trainsets at stations.

(3) *Personnel qualification requirements.* The railroad shall develop, implement, and use a training and testing program, which meets the requirements set forth in this part and part 243 of this chapter, to ensure that all personnel, including railroad employees and employees of railroad contractors, possess the skills and knowledge necessary to effectively perform their duties.

(4) *System qualification tests.* The railroad shall develop, implement, and use a series of operational and design tests, which meet the standards set forth in subpart F of this part, to demonstrate

the safe operation of system components, and the system as a whole.

(d) *Track and infrastructure.* (1) The railroad shall construct its track and infrastructure to meet all material and operational design criteria, within normal acceptable construction tolerances, and to meet the requirements set forth in subpart C of this part.

(2) The railroad shall operate on nominal standard gauge, 1,435 mm (56.5 inches), track.

(3) The railroad shall install and operate on double track throughout the mainlines, with a minimum nominal distance between track centerlines of 4 m (13.1 feet) for operating speeds up to 170 km/h (106 mph) (track Classes up to H4) and 4.2 m (13.8 feet) for operating speeds greater than 170 km/h (106 mph) (track Classes H5 and above). Generally, each track will be used for a single direction of traffic, and trainset will not overtake each other on mainline tracks (except at non-terminal station locations). The railroad may install crossover connections between the double track at each station, and at regular intervals along the line to permit flexibility in trainset operations, maintenance, and emergency rescue.

(4) The railroad's main track (track Classes H4 and above) shall consist of continuous welded rail. Once installed, the rail shall be field-welded to form one continuous track segment except rail expansion joints and where glued-insulated joints are necessary for signaling purposes. The rail shall be JIS E 1101 60 kg rail, as specified in JIS E 1101:2011 as amended by JIS E 1101:2012, and JIS E 1101:2016 (all incorporated by reference, see § 299.17).

(5) In yards and maintenance facilities, where operations will be at lower speeds, the railroad shall install either JIS E 1101 50kgN rail or JIS E 1101 60 kg rail as specified in JIS E 1101:2011 as amended by JIS E 1101:2012, and JIS E 1101:2016 (all incorporated by reference, see § 299.17).

(6) The railroad shall use either ballasted or non-ballasted track to support the track structure, as appropriate for the intended high-speed system.

(i) Except as noted in paragraph (c)(6)(ii) of this section, for ballasted mainline track structure, the railroad shall install pre-stressed concrete ties.

(ii) For special track work such as turnouts and expansion joints, and at transitions to bridges, and for non-ballasted track, the railroad shall install either pre-stressed, composite ties, or use direct fixation. Detailed requirements are included in subpart C of this part.

(7) Turnouts, expansion joints and glued-insulated joints shall be of the proven design as used on the Tokaido Shinkansen system.

(8) The trainsets and stations shall be designed to permit level platform boarding for passengers and crew at all side entrance doors. Provisions for high level boarding shall be made at all locations in trainset maintenance facilities where crew and maintenance personnel are normally required to access or disembark trainsets.

(e) *Signal and trainset control systems.* (1) The railroad's signal and trainset control systems, shall be based upon the service-proven system utilized on the Tokaido Shinkansen system and shall include an automatic train control (ATC) system, interlocking equipment, and wayside equipment, including: Track circuits, transponders, and Go/No-Go signals in stations and trainset maintenance facilities.

(2) The railroad's signaling system shall extend beyond the mainline into trainset maintenance facilities and be designed to prevent collisions at all speeds.

(3) The ATC system shall be designed with a redundant architecture utilizing a intrinsic fail-safe design concept.

(4) The trainset braking curves shall be determined by the on-board equipment based on the ATC signal from the ground facility and on-board database that includes the alignment and rolling stock performance data. The on-board equipment shall generate the braking command based upon the trainset location, speed, and braking curves.

(5) The ATC on-board equipment shall have three modes: Mainline, shunting, and cut-out.

(i) Mainline mode shall be used for operations on mainlines and for entering into the trainset maintenance facilities. The mainline mode of ATC on-board equipment shall provide the following functions:

(A) Prevent train-to-train collisions; and

(B) Prevent overspeed derailments.

(ii) Shunting mode shall be used to protect movements within trainset maintenance facilities and for emergency operations as required by the operating rules. When operating in shunting mode, the trainset shall be restricted to a maximum speed of 30 km/h.

(iii) Cut-out mode shall be used for emergency operations and/or in the event of an ATC system failure as required by the operating rules.

(6) Interlocking equipment shall prevent the movement of trainsets through a switch in an improper

position and command switch-and-lock movements on mainlines and within trainset maintenance facilities.

(7) Track circuits shall be used to provide broken rail detection.

(8) Overrun protection coils shall be used at mainline turnouts, crossovers within stations and trainset maintenance facilities to prevent unauthorized route access.

(9) Transponders shall be used on the mainline to provide trainset position correction. Transponders may be used to provide an overlay of overrun protection within a trainset maintenance facility.

(10) Go/No-Go signals shall be used in stations for shunting and emergency operations and in trainset maintenance facilities to provide trainset movement authority.

(11) The railroad shall include an intrusion detection system as required by paragraph (b)(3) and (5) of this section that shall interface with the ATC system and have the capability to stop the trainset under specified intrusion scenarios.

(f) *Communications.* (1) The railroad shall install a dedicated communication system along the right-of-way to transmit data, telephone, and/or radio communications that is completely isolated and independent of the signal and trainset system. To ensure transmission reliability, the system shall include back-up transmission routes.

(2) For trainset operation and maintenance, the railroad shall install—

(i) A portable radio system for maintenance and service use; and

(ii) A trainset radio, which shall facilitate communication between each trainset and the general control center.

(g) *Rolling stock.* (1) The railroad's rolling stock shall be designed, operated, and maintained in accordance with the requirements set forth in subparts D, E, and H of this part.

(2) The railroad shall utilize bi-directional, fixed-consist, electric multiple unit (EMU), high-speed trainsets based on the N700.

(3) Each trainset shall be equipped with wheel slide control.

(4) Each trainset shall be equipped with two electrically connected pantographs. The position of the pantographs (up or down) shall be displayed in the driver's cab.

(5) The driver's cab shall be a full width and dedicated cab and shall be arranged to enhance safety of operation, range of vision, visibility and readability of controls and indicators, accessibility of controls, and climate control.

(6) The railroad's passenger equipment brake system shall be based

on the N700's design and shall meet the following standards:

(i) Each trainset shall be equipped with an electronically controlled brake system that shall ensure that each unit in the trainset responds independently to a brake command. The brake command shall be transmitted through the on-board internal trainset control network, as well as through the trainline for redundancy.

(A) Motorized cars shall be equipped with regenerative and electronically controlled pneumatic brakes. The system shall be designed to maximize the use of regenerative brakes.

(B) Non-motorized cars shall be equipped with electronically controlled pneumatic brakes.

(C) The friction brakes on each bogie shall be cheek mounted disc brakes.

(D) Each car shall be equipped with an electronic and pneumatic brake control unit and a main reservoir. The system shall be designed that in the event of a failure of an electronic control unit in a car, brake control shall be provided by the electronic control unit on the adjacent car. Each car in the trainset shall be equipped with a backup wheel slide protection controller that will provide wheel slide protection in the event of a wheel slide protection controller failure.

(ii) The braking system shall be designed with the following brake controls: Service, emergency, urgent, and rescue brake.

(iii) The service and emergency brake shall be applied automatically by ATC or manually by the driver.

(iv) The urgent brake control shall be independent of the service and emergency brake control and shall be automatically applied if the trainset is parted. Application of the urgent brake shall produce an irretrievable stop. The urgent brake force shall be designed to vary according to speed in order to minimize the braking distance and avoid excessive demand of adhesion at higher speeds.

(v) A disabled trainset shall be capable of having its brake system controlled electronically by a rescue trainset.

(vi) Independent of the driver's brake handle in the cab, each trainset shall be equipped with two urgent brake switches in each cab car, accessible only to the crew; located adjacent to the door control station and that can initiate an urgent brake application. If door control stations are provided in intermediate cars that are accessible only to crew members, then the urgent brake switches must also be included adjacent to the door control stations.

(vii) The railroad shall establish a maximum safe operating speed to address brake failures that occur in revenue service as required by § 299.409(f)(4). In the event of any friction brake failure on a trainset, the speed shall be limited by ATC on-board equipment in accordance with the brake failure switch position selected by the driver and as required by § 299.447.

#### § 299.15 Special approvals.

(a) *General.* The following procedures govern consideration and action upon requests for special approval of alternative standards to this part.

(b) *Petitions for special approval of alternative standard.* Each petition for special approval of an alternative standard shall contain—

(1) The name, title, address, and telephone number of the primary person to be contacted with regard to review of the petition;

(2) The alternative proposed, in detail, to be substituted for the particular requirements of this part; and

(3) Appropriate data or analysis, or both, establishing that the alternative will provide at least an equivalent level of safety.

(c) *Petitions for special approval of alternative compliance.* Each petition for special approval of alternative compliance shall contain—

(1) The name, title, address, and telephone number of the primary person to be contacted with regard to the petition;

(2) High-speed core systems and system components of special design shall be deemed to comply with this part, if the FRA Associate Administrator determines under paragraph (d) of this section that the core system or system components provide at least an equivalent level of safety in the environment defined within § 299.13 with respect to the protection of railroad employees and the public. In making a determination under paragraph (d) of this section the Associate Administrator shall consider, as a whole, all of those elements of casualty prevention or mitigation relevant to the integrity of the core system or components that are addressed by the requirements of this part.

(d) *Petition contents.* The Associate Administrator may only make a finding of equivalent safety and compliance with this part, based upon a submission of data and analysis sufficient to support that determination. The petition shall include—

(1) The information required by § 299.15(b) or (c), as appropriate; Information, including detailed drawings and materials specifications,

sufficient to describe the actual construction and function of the core systems or system components of special design;

(2) A quantitative risk assessment, incorporating the design information and engineering analysis described in this paragraph, demonstrating that the core systems or system components, as utilized in the service environment defined in § 299.13, presents no greater hazard of serious personal injury than existing core system or system components that conform to the specific requirements of this part.

(e) **Federal Register notice.** FRA will publish a notice in the **Federal Register** concerning each petition under paragraphs (b) and (c) of this section.

(f) *Comment.* Not later than 30 days from the date of publication of the notice in the **Federal Register** concerning a petition under paragraphs (b) and (c) of this section, any person may comment on the petition.

(1) Each comment shall set forth specifically the basis upon which it is made, and contain a concise statement of the interest of the commenter in the proceeding.

(2) Each comment shall be submitted to the U.S. Department of Transportation, Docket Operations (M-30), West Building Ground Floor, Room W12-140, 1200 New Jersey Avenue SE, Washington, DC 20590, and shall contain the assigned docket number for that proceeding. The form of such submission may be in written or electronic form consistent with the standards and requirements established by the Federal Docket Management System and posted on its website at <http://www.regulations.gov>.

(g) *Disposition of petitions.* (1) FRA will conduct a hearing on a petition in accordance with the procedures provided in § 211.25 of this chapter.

(2) If FRA finds that the petition complies with the requirements of this section or that the proposed plan is acceptable the petition will be granted, normally within 90 days of its receipt. If the petition is neither granted nor denied within 90 days, the petition remains pending for decision. FRA may attach special conditions to the approval of the petition. Following the approval of a petition, FRA may reopen consideration of the petition for cause stated.

(3) If FRA finds that the petition does not comply with the requirements of this section, or that the proposed plan is not acceptable or that the proposed changes are not justified, or both, the petition will be denied, normally within 90 days of its receipt.

(4) When FRA grants or denies a petition, or reopens consideration of the petition, written notice is sent to the petitioner and other interested parties.

**§ 299.17 Incorporation by reference.**

Certain material is incorporated by reference into this part with the approval of the Director of the Federal Register under 5 U.S.C. 552(a) and 1 CFR part 51. All approved material is available for inspection at Federal Railroad Administration, Docket Clerk, 1200 New Jersey Avenue SE, Washington, DC 20590 (telephone: 202-493-6052); email: [FRALegal@dot.gov](mailto:FRALegal@dot.gov) and is available from the sources indicated in this section. It is also available for inspection at the National Archives and Records Administration (NARA). For information on the availability of this material at NARA, email [fedreg.legal@nara.gov](mailto:fedreg.legal@nara.gov) or go to [www.archives.gov/federal-register/cfr/ibr-locations.html](http://www.archives.gov/federal-register/cfr/ibr-locations.html).

(a) ASTM International, 100 Barr Harbor Drive, PO Box C700, West Conshohocken, PA 19428-2959, [www.astm.org](http://www.astm.org).

(1) ASTM D 4956-07<sup>e1</sup>, Standard Specification for Retroreflective Sheeting for Traffic Control, approved March 15, 2007; into § 299.423.

(2) ASTM E 810-03, Standard Test Method for Coefficient of Retroreflection of Retroreflective Sheeting Utilizing the Coplanar Geometry, approved February 10, 2003; into § 299.423.

(3) ASTM E 2073-07, Standard Test Method for Photopic Luminance of Photoluminescent (Phosphorescent) Markings, approved July 1, 2007; into § 299.423.

(b) Japanese Standards Association 4-1-24, Akasaka, Minato-ku, Tokyo, 107-8440 Japan, [www.jsa.or.jp](http://www.jsa.or.jp) (Japanese site), or [www.jsa.or.jp/en](http://www.jsa.or.jp/en) (English site).

(1) JIS E 7105:2006(E), “Rolling Stock—Test methods of static load for body structures,” Published February 20, 2006; into § 299.403.

(2) JIS E 7105:2011(E), “Rolling Stock—Test methods of static load for body structures,” (Amendment 1) Published September 7, 2011; into § 299.403.

(3) JIS E 1101:2001(E), “Flat bottom railway rails and special rails for switches and crossings of non-treated steel,” Published June 30, 2001; into § 299.13.

(4) JIS E 1101:2006(E) “Flat bottom railway rails and special rails for switches and crossings of non-treated steel,” (Amendment 1), Published March 25, 2006; into § 299.13.

(5) JIS E 1101:2012(E) “Flat bottom railway rails and special rails for switches and crossings of non-treated

steel,” (Amendment 2), Published February 20, 2012; into § 299.13.

(6) JIS B 8265 “Construction of pressure vessels-general principles,” Published December 27, 2010; into § 299.409.

**Subpart B—Signal and Trainset Control System**

**§ 299.201 Technical PTC system requirements.**

(a) The railroad shall comply with all applicable requirements under 49 U.S.C. 20157, including, but not limited to, the statutory requirement to fully implement an FRA-certified PTC system prior to commencing revenue service.

(b) The railroad’s PTC system shall be designed to reliably and functionally prevent train-to-train collisions, over-speed derailments, incursions into established work zone limits, and movements of trainset through switches left in the wrong position, in accordance with § 236.1005(a) and (c) through (f) of this chapter.

(c) The railroad is authorized to conduct field testing of its PTC system on its system, prior to obtaining PTC System Certification from FRA, in accordance with its system-wide qualification plan under § 299.603. During any field testing of its uncertified PTC system and regression testing of its FRA-certified PTC system, FRA may oversee the railroad’s testing, audit any applicable test plans and procedures, and impose additional testing conditions that FRA believes may be necessary for the safety of trainset operations.

(d) The railroad is not exempted from compliance with any requirement of subparts A through G of 49 CFR part 236, or parts 233, and 235 of this chapter, unless the railroad’s FRA-approved PTCSP provides for such an exception.

(e)(1) All materials filed in accordance with this subpart must be in the English language, or have been translated into English and attested as true and correct.

(2) Each filing referenced in this subpart may include a request for full or partial confidentiality in accordance with § 209.11 of this chapter. If confidentiality is requested as to a portion of any applicable document, then in addition to the filing requirements under § 209.11 of this chapter, the person filing the document shall also file a copy of the original unredacted document, marked to indicate which portions are redacted in the document’s confidential version without obscuring the original document’s contents.

**§ 299.203 PTC system required.**

The railroad shall not commence revenue service prior to installing and making operative its FRA-certified PTC system.

**§ 299.205 PTC System Certification.**

(a) Prior to operating its PTC system in revenue service, the railroad must first obtain a PTC System Certification from FRA by submitting an acceptable PTCSP and obtaining FRA’s approval of its PTCSP.

(b) Each PTCSP requirement under this subpart shall be supported by information and analysis sufficient to establish that the PTC system meets the requirements of § 236.1005(a) and (c) through (f) of this chapter.

(c) If the Associate Administrator finds that the PTCSP and its supporting documentation support a finding that the PTC system complies with §§ 236.1005(a) and (c) through (f) of this chapter, and 299.211, the Associate Administrator shall approve the PTCSP. If the Associate Administrator approves the PTCSP, the railroad shall receive PTC System Certification for its PTC system and shall implement the PTC system according to the PTCSP.

(d) Issuance of a PTC System Certification is contingent upon FRA’s confidence in the implementation and operation of the subject PTC system. This confidence may be based on FRA-monitored field testing or an independent assessment performed in accordance with § 236.1017 of this chapter.

(e)(1) As necessary to ensure safety, FRA may attach special conditions to its certification of the railroad’s PTC System.

(2) After granting a PTC System Certification, FRA may reconsider the PTC System Certification upon revelation of any of the following factors concerning the contents of the PTCSP:

(i) Potential error or fraud;

(ii) Potentially invalidated assumptions determined as a result of in-service experience or one or more unsafe events calling into question the safety analysis supporting the approval.

(3) During FRA’s reconsideration in accordance with this paragraph, the PTC system may remain in use if otherwise consistent with the applicable law and regulations, and FRA may impose special conditions for use of the PTC system.

(4) After FRA’s reconsideration in accordance with this paragraph, FRA may:

(i) Dismiss its reconsideration and continue to recognize the existing PTC System Certification;



(ii) Allow continued operations under such conditions the Associate Administrator deems necessary to ensure safety; or

(iii) Revoke the PTC System Certification and direct the railroad to cease operations.

(f) FRA shall be afforded reasonable access to monitor, test, and inspect processes, procedures, facilities, documents, records, design and testing materials, artifacts, training materials and programs, and any other information used in the design, development, manufacture, test, implementation, and operation of the system, as well as interview any personnel.

(g) Information that has been certified under the auspices of a foreign regulatory entity recognized by the Associate Administrator may, at the Associate Administrator's sole discretion, be accepted as independently verified and validated and used to support the railroad's PTCSP.

(h) The railroad shall file its PTCSP in FRA's Secure Information Repository at <https://sir.fra.dot.gov>, consistent with § 299.201(e).

**§ 299.207 PTC Safety Plan content requirements.**

(a) The railroad's PTCSP shall contain the following elements:

(1) A hazard log consisting of a comprehensive description of all safety-relevant hazards of the PTC system, specific to implementation on the railroad, including maximum threshold limits for each hazard (for unidentified hazards, the threshold shall be exceeded at one occurrence);

(2) A description of the safety assurance concepts that are to be used for system development, including an explanation of the design principles and assumptions;

(3) A risk assessment of the as-built PTC system;

(4) A hazard mitigation analysis, including a complete and comprehensive description of each hazard and the mitigation techniques used;

(5) A complete description of the safety assessment and Verification and Validation processes applied to the PTC system, their results, and whether these processes address the safety principles described in appendix C to part 236 of this chapter directly, using other safety criteria, or not at all;

(6) A complete description of the railroad's training plan for railroad and contractor employees and supervisors necessary to ensure safe and proper installation, implementation, operation,

maintenance, repair, inspection, testing, and modification of the PTC system;

(7) A complete description of the specific procedures and test equipment necessary to ensure the safe and proper installation, implementation, operation, maintenance, repair, inspection, testing, and modification of the PTC system on the railroad and establish safety-critical hazards are appropriately mitigated. These procedures, including calibration requirements, shall be consistent with or explain deviations from the equipment manufacturer's recommendations;

(8) A complete description of the configuration or revision control measures designed to ensure that the railroad or its contractor does not adversely affect the safety-functional requirements and that safety-critical hazard mitigation processes are not compromised as a result of any such change;

(9) A complete description of all initial implementation testing procedures necessary to establish that safety-functional requirements are met and safety-critical hazards are appropriately mitigated;

(10) A complete description of all post-implementation testing (validation) and monitoring procedures, including the intervals necessary to establish that safety-functional requirements, safety-critical hazard mitigation processes, and safety-critical tolerances are not compromised over time, through use, or after maintenance (adjustment, repair, or replacement) is performed;

(11) A complete description of each record necessary to ensure the safety of the system that is associated with periodic maintenance, inspections, tests, adjustments, repairs, or replacements, and the system's resulting conditions, including records of component failures resulting in safety-relevant hazards (*see* § 299.213);

(12) A safety analysis to determine whether, when the system is in operation, any risk remains of an unintended incursion into a roadway work zone due to human error. If the analysis reveals any such risk, the PTCSP shall describe how that risk will be mitigated;

(13) A complete description of how the PTC system will enforce authorities and signal indications;

(14) A complete description of how the PTC system will appropriately and timely enforce all integrated hazard detectors in accordance with § 236.1005 of this chapter;

(15) The documents and information required under § 299.211;

(16) A summary of the process for the product supplier or vendor to promptly

and thoroughly report any safety-relevant failures or previously unidentified hazards to the railroad, including when another user of the product experiences a safety-relevant failure or discovers a previously unidentified hazard;

(17) Documentation establishing—by design, data, or other analysis—that the PTC system meets the fail-safe operation criteria under paragraph (b)(4)(v) of appendix C to part 236 of this chapter; and,

(18) An analysis establishing that the PTC system will be operated at a level of safety comparable to that achieved over the 5-year period prior to the submission of the railroad's PTCSP by other train control systems that perform PTC functions, and which have been utilized on high-speed rail systems with similar technical and operational characteristics in the United States or in foreign service.

(b) As the railroad's PTC system may be considered a stand-alone system pursuant to § 236.1015(e)(3) of this chapter, the following requirements apply:

(1) The PTC system shall reliably execute the functions required by § 236.1005 of this chapter and be demonstrated to do so to FRA's satisfaction; and

(2) The railroad's PTCSP shall establish, with a high degree of confidence, that the system will not introduce any hazards that have not been sufficiently mitigated.

(c) When determining whether the PTCSP fulfills the requirements under this section, the Associate Administrator may consider all available evidence concerning the reliability of the proposed system.

(d) When reviewing the issue of the potential data errors (for example, errors arising from data supplied from other business systems needed to execute the braking algorithm, survey data needed for location determination, or mandatory directives issued through the computer-aided dispatching system), the PTCSP must include a careful identification of each of the risks and a discussion of each applicable mitigation. In an appropriate case, such as a case in which the residual risk after mitigation is substantial, the Associate Administrator may require submission of a quantitative risk assessment addressing these potential errors.

(e) The railroad must comply with the applicable requirements under § 236.1021 of this chapter prior to modifying a safety-critical element of an FRA-certified PTC system.

(f) If a PTCSP applies to a PTC system designed to replace an existing certified

PTC system, the PTCSP will be approved provided that the PTCSP establishes with a high degree of confidence that the new PTC system will provide a level of safety not less than the level of safety provided by the system to be replaced.

**§ 299.209 PTC system use and failures.**

(a) When any safety-critical PTC system component fails to perform its intended function, the cause must be determined and the faulty component adjusted, repaired, or replaced without undue delay. Until repair of such essential components is completed, the railroad shall take appropriate action as specified in its PTCSP.

(b) Where a trainset that is operating in, or is to be operated within, a PTC-equipped track segment experiences a PTC system failure or the PTC system is otherwise cut out while en route (*i.e.*, after the trainset has departed its initial terminal), the trainset may only continue in accordance with all of the following:

(1) Except as provided in paragraph (b)(4) of this section, when no absolute block protection is established, the trainset may proceed at a speed not to exceed restricted speed.

(2) When absolute block protection can be established in advance of the trainset, the trainset may proceed at a speed not to exceed 120 km/h (75 mph), and the trainset shall not exceed restricted speed until the absolute block in advance of the trainset is established.

(3) A report of the failure or cut-out must be made to a designated railroad officer of the railroad as soon as safe and practicable.

(4) Where the PTC system is the exclusive method of delivering mandatory directives, an absolute block must be established in advance of the trainset as soon as safe and practicable, and the trainset shall not exceed restricted speed until the absolute block in advance of the trainset is established.

(5) Where the failure or cut-out is a result of a defective onboard PTC apparatus, the trainset may be moved in passenger service only to the next forward location where the necessary repairs can be made; however, if the next forward location where the necessary repairs can be made does not have the facilities to handle the safe unloading of passengers, the trainset may be moved past the repair location in service only to the next forward passenger station in order to facilitate the unloading of passengers. When the passengers have been safely unloaded, the defective trainset shall be moved to the nearest location where the onboard

PTC apparatus can be repaired or exchanged.

(c) The railroad shall comply with all provisions in its PTCSP for each PTC system it uses and shall operate within the scope of initial operational assumptions and predefined changes identified.

(d) The normal functioning of any safety-critical PTC system must not be interfered with in testing or otherwise without first taking measures to provide for the safe movement of trainsets that depend on the normal functioning of the system.

(e) Annually, by April 16 of each year following the commencement of the railroad's revenue service, the railroad shall provide FRA with a report of the number of PTC failures that occurred during the previous calendar year. The report shall identify failures by category, including but not limited to locomotive, wayside, communications, and back office system failures.

(f) The railroad and the PTC system vendors and/or suppliers must comply with each applicable requirement under § 236.1023 of this chapter.

**§ 299.211 Communications and security requirements.**

(a) All wireless communications between the office, wayside, and onboard components in a PTC system shall provide cryptographic message integrity and authentication.

(b) Cryptographic keys required under this section shall—

(1) Use an algorithm approved by the National Institute of Standards or a similarly recognized and FRA-approved standards body;

(2) Be distributed using manual or automated methods, or a combination of both; and

(3) Be revoked—

(i) If compromised by unauthorized disclosure of the cleartext key; or

(ii) When the key algorithm reaches its lifespan as defined by the standards body responsible for approval of the algorithm.

(c) The cleartext form of the cryptographic keys shall be protected from unauthorized disclosure, modification, or substitution, except during key entry when the cleartext keys and key components may be temporarily displayed to allow visual verification. When encrypted keys or key components are entered, the cryptographically protected cleartext key or key components shall not be displayed.

(d) Access to cleartext keys shall be protected by a tamper-resistant mechanism.

(e) If the railroad elects to also provide cryptographic message confidentiality, it shall:

(1) Comply with the same requirements for message integrity and authentication under this section; and

(2) Only use keys meeting or exceeding the security strength required to protect the data as defined in the railroad's PTCSP.

(f) The railroad, or its vendor or supplier, shall have a prioritized service restoration and mitigation plan for scheduled and unscheduled interruptions of service. This plan shall be made available to FRA upon request, without undue delay, for restoration of communication services that support PTC system services.

**§ 299.213 Records retention.**

(a) The railroad shall maintain at a designated office on the railroad—

(1) A current copy of each FRA-approved PTCSP that it holds;

(2) Adequate documentation to demonstrate that the PTCSP meets the safety requirements of this RPA, including the risk assessment;

(3) An Operations and Maintenance Manual, pursuant to § 299.215; and

(4) Training and testing records pursuant to § 236.1043(b) of this chapter.

(b) Results of inspections and tests specified in the PTCSP must be recorded pursuant to § 236.110 of this chapter.

(c) Each contractor providing services relating to the testing, maintenance, or operation of the railroad's PTC system shall maintain at a designated office training records required under §§ 236.1043(b) of this chapter, and 299.207(a)(6).

(d) After the PTC system is placed in service, the railroad shall maintain a database of all safety-relevant hazards as set forth in its PTCSP and those that had not been previously identified in its PTCSP. If the frequency of the safety-relevant hazards exceeds the threshold set forth in its PTCSP, then the railroad shall—

(1) Report the inconsistency in writing to FRA's Secure Information Repository at <https://sir.fra.dot.gov>, within 15 days of discovery;

(2) Take prompt countermeasures to reduce the frequency of each safety-relevant hazard to below the threshold set forth in its PTCSP; and

(3) Provide a final report when the inconsistency is resolved to FRA's Secure Information Repository at <https://sir.fra.dot.gov>, on the results of the analysis and countermeasures taken to reduce the frequency of the safety-relevant hazard(s) below the threshold set forth in its PTCSP.



TABLE 1 TO § 299.311—Continued

Track geometry parameter (mm)	Track class	H0	H1	H2	H3	H4	H5	H6	H7
The deviation from uniformity <sup>1</sup> of the mid-chord offset on either rail for a 10 m chord (alignment) may not be more than—.	10 m chord ....	38	31	31	14	12	10	8	7
The deviation from uniform profile on either rail at the mid-ordinate of a 10 m chord (surface) may not be more than—.	10 m chord ....	40	40	40	27	22	18	15	13
The deviation from uniform crosslevel at any point on tangent and curved track may not be more than—.	.....	50	26	26	22	18	14	9	9
The difference in crosslevel between any two points 2.5 meters (8.2 feet) apart (twist) may not be more than—.	2.5 m .....	26	26	26	22	18	14	9	9

<sup>1</sup> Uniformity for alignment at any point along the track is established by averaging the measured mid-chord offset values for a 10 m (32.8 feet) chord for nine consecutive points that are centered around that point and spaced at 2.5-meter (8.2 feet) intervals.

**§ 299.313 Track geometry; performance based.**

(a) For all track of Class H4 and above, vibration in the lateral and vertical directions measured on the carbody of a vehicle representative of the service fleet traveling at a speed no less than 10 km/h (6.2 mph) below the maximum speed permitted for the class of track, shall not exceed the limits prescribed in the following table:

TABLE 1 TO PARAGRAPH (A)

Carbody acceleration limits <sup>1 2</sup>	
Lateral vibration <sup>3</sup>	Vertical vibration <sup>3</sup>
≤0.35 g peak-to-peak 1 sec window ..... excluding peaks <50 msec.	≤0.45 g peak-to-peak. 1 sec window. excluding peaks <50 msec.

<sup>1</sup> Carbody accelerations in the vertical and lateral directions shall be measured by accelerometers oriented and located in accordance with § 299.331(c)(3).

<sup>2</sup> Acceleration measurements shall be processed through an LPF with a minimum cut-off frequency of 10 Hz. The sample rate for acceleration data shall be at least 200 samples per second.

<sup>3</sup> Peak-to-peak accelerations shall be measured as the algebraic difference between the two extreme values of measured acceleration in any 1-second time period, excluding any peak lasting less than 50 milliseconds.

(b) If the carbody acceleration requirements are not met on a segment of track, the segment of track is to be reclassified to the next lower Class of track for which it does meet the requirements of this part.

**§ 299.315 Curves; elevation and speed limitations.**

(a) The maximum elevation of the outside rail of a curve may not be more than 200 mm (7<sup>7</sup>/<sub>8</sub> inches). The outside rail of a curve may not be lower than the inside rail by design, except when engineered to address specific track or

operating conditions; the limits in § 299.311 apply in all cases.

(b) The maximum allowable posted timetable operating speed for each curve is determined by the following formula:

$$V_{max} = \sqrt{\frac{(E_a + E_u) \times R}{11.8}}$$

Where—

$V_{max}$  = Maximum allowable posted timetable operating speed (km/h).

$E_a$  = Actual elevation of the outside rail (mm). Actual elevation,  $E_a$ , for each 50-meter track segment in the body of the curve is determined by averaging the elevation for 11 points through the segment at 5-meter spacing. If the curve length is less than 50-meters, average the points through the full length of the body of the curve.

$E_u$  = Qualified cant deficiency (mm) of the vehicle type.

$R$  = Radius of curve (m). Radius of curve,  $R$ , is determined by averaging the radius of the curve over the same track segment as the elevation.

(c) All vehicles are considered qualified for operating on track with a cant deficiency,  $E_u$ , not exceeding 75 mm (3 inches).

(d) Each vehicle type must be approved by FRA, under § 299.609, to operate on track with a qualified cant deficiency,  $E_u$ , greater than 75 mm (3 inches). Each vehicle type must demonstrate in a ready-for-service load condition, compliance with the requirements of either paragraph (d)(1) or (2) of this section.

(1) When positioned on a track with a uniform superelevation equal to the proposed cant deficiency:

(i) No wheel of the vehicle unloads to a value less than 60 percent of its static value on perfectly level track; and

(ii) For passenger cars, the roll angle between the floor of the equipment and the horizontal does not exceed 8.6 degrees; or

(2) When operating through a constant radius curve at a constant speed corresponding to the proposed cant deficiency, and a test plan is submitted and approved by FRA in accordance with § 299.609(d)—

(i) The steady-state (average) load on any wheel, throughout the body of the curve, is not less than 60 percent of its static value on perfectly level track; and

(ii) For passenger cars, the steady-state (average) lateral acceleration measured on the floor of the carbody does not exceed 0.15 g.

(e) The railroad shall transmit the results of the testing specified in paragraph (d) of this section to FRA in accordance with §§ 299.9 and 299.613 requesting approval under § 299.609(g) for the vehicle type to operate at the desired curving speeds allowed under the formula in paragraph (b) of this section. The request shall be made in writing and shall contain, at a minimum, the following information:

(1) A description of the vehicle type involved, including schematic diagrams of the suspension system(s) and the estimated location of the center of gravity above top of rail; and

(2) The test procedure, including the load condition under which the testing was performed, and description of the instrumentation used to qualify the vehicle type, as well as the maximum values for wheel unloading and roll angles or accelerations that were observed during testing.

**Note 1 to paragraph (e)(2).** The test procedure may be conducted whereby all the wheels on one side (right or left) of the vehicle are raised to the proposed cant deficiency and lowered, and then the vertical wheel loads under each wheel are measured and a level is used to record the angle through which the floor of the vehicle has been rotated.

(f) Upon FRA approval of the request to approve the vehicle type to operate at

the desired curving speeds allowed under the formula in paragraph (b) of this section, the railroad shall notify FRA in accordance with § 299.9 in writing no less than 30 calendar days prior to the proposed implementation of the approved higher curving speeds allowed under the formula in paragraph (b) of this section. The notification shall contain, at a minimum, identification of the track segment(s) on which the higher curving speeds are to be implemented.

(g) As used in this section, and §§ 299.331 and 299.609, vehicle type means like vehicles with variations in their physical properties, such as suspension, mass, interior arrangements, and dimensions that do not result in significant changes to their dynamic characteristics.

**§ 299.317 Track strength.**

(a) Track shall have a sufficient vertical strength to withstand the maximum vehicle loads generated at maximum permissible trainset speeds,

cant deficiencies and surface limitations. For purposes of this section, vertical track strength is defined as the track capacity to constrain vertical deformations so that the track shall, under maximum load, remain in compliance with the track performance and geometry requirements of this part.

(b) Track shall have sufficient lateral strength to withstand the maximum thermal and vehicle loads generated at maximum permissible trainset speeds, cant deficiencies and lateral alignment limitations. For purposes of this section lateral track strength is defined as the track capacity to constrain lateral deformations so that track shall, under maximum load, remain in compliance with the track performance and geometry requirements of this part.

**§ 299.319 Track fixation and support.**

(a) Crossties, if used shall be of concrete or composite construction, unless otherwise approved by FRA under § 299.15, for all tracks over which trainsets run in revenue service.

(b) Each 25 m (82 feet) segment of track that contains crossties shall have—

(1) A sufficient number of crossties to provide effective support that will—

- (i) Hold gauge within limits prescribed in § 299.311;
- (ii) Maintain surface within the limits prescribed in § 299.311;
- (iii) Maintain alignment within the limits prescribed in § 299.311; and
- (iv) Maintain longitudinal rail restraint.

(2) The minimum number and type of crossties specified in paragraph (b)(4) of this section and described in paragraph (c) or (d) of this section, as applicable, effectively distributed to support the entire segment;

(3) At least one non-defective crosstie of the type specified in paragraphs (c) and (d) of this section that is located at a joint location as specified in paragraph (e) of this section; and

(4) The minimum number of crossties as indicated in the following table:

TABLE 1 TO PARAGRAPH (b)(4)

Minimum number of non-defective crossties			
Track class	Other than on non-ballasted bridge & turnout	Non-ballasted bridge	Turnout
H0 .....	20 .....	26	24
H1 .....	28 .....	36	33
H2 .....	31, unless inside a TMF, then 28 .....	36	33
H3 .....	35 .....	40	37
H4–H7 .....	39 .....	45	41

(c) Crossties, other than concrete, counted to satisfy the requirements set forth in paragraph (b)(4) of this section shall not be—

- (1) Broken through;
- (2) Split or otherwise impaired to the extent the crossties will allow the ballast to work through, or will not hold spikes or rail fasteners;
- (3) Deteriorated so that the tie plate or base of rail can move laterally 9.5 mm (3/8 inch) relative to the crossties;
- (4) Cut by the tie plate through more than 40 percent of a crosstie's thickness;
- (5) Configured with less than 2 rail holding spikes or fasteners per tie plate; or
- (6) Unable, due to insufficient fastener toeload, to maintain longitudinal restraint and maintain rail hold down and gauge.

(d) Concrete crossties counted to satisfy the requirements set forth in

paragraph (b)(4) of this section shall not be—

- (1) Broken through or deteriorated to the extent that prestressing material is visible;
- (2) Deteriorated or broken off in the vicinity of the shoulder or insert so that the fastener assembly can either pull out or move laterally more than 9.5 mm (3/8 inch) relative to the crosstie;
- (3) Deteriorated such that the base of either rail can move laterally more than 9.5 mm (3/8 inch) relative to the crosstie;
- (4) Deteriorated so that rail seat abrasion is sufficiently deep so as to cause loss of rail fastener toeload;
- (5) Deteriorated such that the crosstie's fastening or anchoring system is unable to maintain longitudinal rail restraint, or maintain rail hold down, or maintain gauge due to insufficient fastener toeload; or

(6) Configured with less than two fasteners on the same rail.

(e) Classes H0 and H1 track shall have one crosstie whose centerline is within 0.61 m (24 inches) of each rail joint (end) location. Classes H2 and H3 track shall have one crosstie whose centerline is within 0.46 m (18 inches) of each rail joint (end) location. Classes H4–H7 track shall have one crosstie whose centerline is within 0.32 m (12.6 inches) of each rail joint (end) location. The relative position of these crossties is described in the following three diagrams:

(1) Each rail joint in Classes H0 and H1 track shall be supported by at least one crosstie specified in paragraphs (d) and (e) of this section whose centerline is within 1.22 m (48 inches) as shown in Figure 1 to this paragraph.

Figure 1 to paragraph (e)(1) - Classes H0 and H1

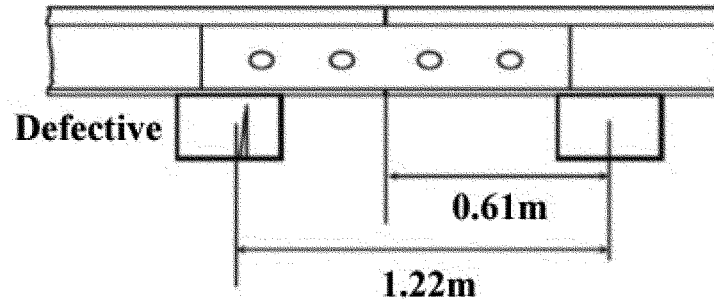

(2) Each rail joint in Classes H2 and H3 track shall be supported by at least one crosstie specified in paragraphs (c) and (d) of this section whose centerline is within 0.92 m (36.2 inches) as shown in Figure 2 to this paragraph.

Figure 2 to paragraph (e)(2) - Classes H2 and H3

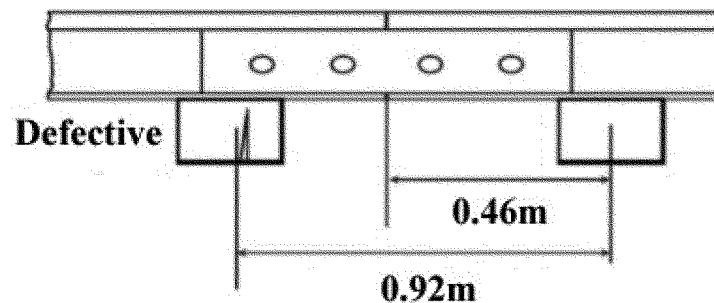

(3) Each rail joint in Classes H4–H7 track shall be supported by at least one crosstie specified in paragraphs (c) and (d) of this section whose centerline is within 0.64 m (25.2 inches) as shown in Figure 3 to this paragraph.

Figure 3 to paragraph (e)(3) - Classes H4 - H7

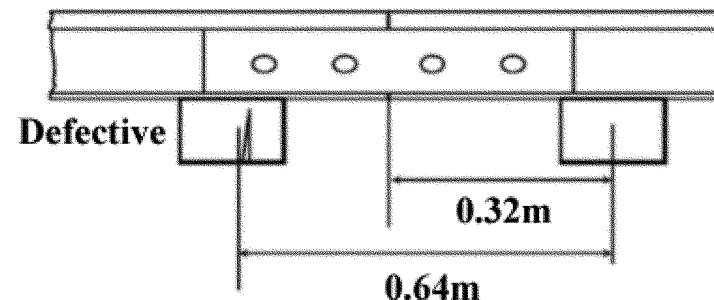

(f) In Class H3 track there shall be at least two non-defective ties each side of a defective tie.

(g) In Classes H4 to H7 track and at any expansion joints there shall be at least three non-defective ties each side of a defective tie.

(h) Defective ties shall be replaced in accordance with the railroad's inspection, testing, and maintenance program.

(i) Track shall be fastened by a system of components that effectively maintains gauge within the limits

prescribed in § 299.311. Each component of each such system shall be evaluated to determine whether gauge is effectively being maintained.

(j) For track constructed without crossties, such as slab track and track connected directly to bridge structural components, track over servicing pits, etc., the track structure shall be sufficient to maintain the geometry limits specified in § 299.311.

#### § 299.321 Defective rails.

(a) The railroad's inspection, testing, and maintenance program shall include a description of defective rails consistent with the practice on the Tokaido Shinkansen system. The inspection, testing, and maintenance program shall include identification of rail defect types, definition of the inspection criteria, time required for verification and the corresponding remedial action.

(b) When the railroad learns that a rail in that track contains any of the defects listed in the railroad's inspection, testing, and maintenance program, a person designated under § 299.353 or 299.355 shall determine whether the track may continue in use. If the designated person determines that the track may continue in use, operation over the defective rail is not permitted until—

- (1) The rail is replaced or repaired; or
- (2) The remedial action prescribed in the inspection, testing, and maintenance program is initiated.

**§ 299.323 Continuous welded rail (CWR) plan.**

(a) The railroad shall have in effect and comply with a plan that contains written procedures which address: The installation, adjustment, maintenance, and inspection of CWR; and inspection of CWR joints.

(b) The railroad shall file its CWR plan with FRA pursuant to § 299.9. The initial CWR plan shall be filed 60 days prior to installation of any CWR track. The effective date of the plan is the date the plan is filed with FRA.

(c) The railroad's existing plan shall remain in effect until the railroad's new plan is developed and filed with FRA.

**§ 299.325 Continuous welded rail (CWR); general.**

The railroad shall comply with the contents of the CWR plan developed under § 299.323. The plan shall contain the following elements—

(a) Procedures for the installation and adjustment of CWR which include—

- (1) Designation of a desired rail installation temperature range for the

geographic area in which the CWR is located;

(2) De-stressing procedures/methods which address proper attainment of the desired rail installation temperature range when adjusting CWR; and

(3) Glued insulated or expansion joint installation and maintenance procedures.

(b) Rail anchoring, if used, or fastening requirements that will provide sufficient restraint to limit longitudinal rail and crosstie movement to the extent practical, and that specifically address CWR rail anchoring or fastening patterns on bridges, bridge approaches, and at other locations where possible longitudinal rail and crosstie movement associated with normally expected trainset-induced forces—is restricted.

(c) CWR joint installation and maintenance procedures.

(d) Procedures which specifically address maintaining a desired rail installation temperature range when cutting CWR including rail repairs, in-track welding, and in conjunction with adjustments made in the area of tight track, a track buckle, or a pull-apart.

(e) Procedures which control trainset speed on CWR track when—

(1) Maintenance work, track rehabilitation, track construction, or any other event occurs which disturbs the roadbed or ballast section and reduces the lateral or longitudinal resistance of the track; and

(2) The difference between the rail temperature and the rail neutral temperature is in a range that causes buckling-prone conditions to be present at a specific location.

(f) Procedures which prescribe when and where physical track inspections are to be performed under extreme temperature conditions.

(g) Scheduling and procedures for inspections to detect cracks and other indications of potential failures in CWR joints.

(h) The railroad shall have in effect a comprehensive training program for the application of these written CWR procedures, with provisions for periodic retraining for those individuals designated as qualified in accordance with this subpart to supervise the installation, adjustment, and maintenance of CWR track and to perform inspections of CWR track.

(i) The plan shall prescribe and require compliance with recordkeeping requirements necessary to provide an adequate history of track constructed with CWR. At a minimum, these records shall include—

(1) The rail laying temperature, location, and date of CWR installations. Each record shall be retained until the rail neutral temperature has been adjusted; and

(2) A record of any CWR installation or maintenance work that does not conform to the written procedures. Such record must include the location of the rail and be maintained until the CWR is brought into conformance with such procedures.

**§ 299.327 Rail end mismatch.**

Any mismatch of rails at joints may not be more than that prescribed by the following table:

TABLE 1 TO § 299.327

Track class	Any mismatch of rails at joints may not be more than the following:	
	On the tread of the rail ends	On the gauge side of the rail ends
H0 .....	6 mm	5 mm
H1–H2 .....	4 mm	4 mm
H3–H7 .....	2 mm	2 mm

**§ 299.329 Rail joints and torch cut rails.**

(a) Each rail joint, insulated joint, expansion joint, and compromise joint shall be of a structurally sound design and appropriate dimensions for the rail on which it is applied.

(b) If a joint bar is cracked, broken, or permits excessive vertical movement of either rail when all bolts are tight, it shall be replaced.

(c) Except for glued-insulated joints, each joint bar shall be held in position by track bolts tightened to allow the joint bar to firmly support the abutting

rail ends. For track Classes H0 to H3 track bolts shall be tightened, as required, to allow longitudinal movement of the rail in the joint to accommodate expansion and contraction due to temperature variations.

(d) Except as provided in paragraph (e) of this section, each rail shall be bolted with at least two bolts at each joint.

(e) Clamped joint bars may be used for temporary repair during emergency situations, and speed over that rail end

and the time required to replace the joint bar must not exceed the limits specified in the inspection, testing, and maintenance program.

(f) No rail shall have a bolt hole which is torch cut or burned.

(g) No joint bar shall be reconfigured by torch cutting.

(h) No rail having a torch cut or flame cut end may be used.

**§ 299.331 Turnouts and crossings generally.**

(a) In turnouts and track crossings, the fastenings shall be intact and

maintained to keep the components securely in place. Also, each switch, frog, and guard rail shall be kept free of obstructions that may interfere with the passage of wheels. Use of rigid rail crossings at grade is limited to track Classes H0, H1, and H2.

(b) The track through and on each side of track crossings and turnouts

shall be designed to restrain rail movement affecting the position of switch points and frogs.

(c) Each flangeway at turnouts shall be at least 39 mm (1.5 inches) wide.

(d) For all turnouts and track crossings, the railroad shall prepare inspection and maintenance requirements to be included in the

railroad's inspection, testing, and maintenance program.

**§ 299.333 Frog guard rails and guard faces; gauge.**

The guard check and guard face gauges in frogs shall be within the limits prescribed in the following table:

TABLE 1 TO § 299.333

Track class	<i>Guard check gauge</i> The distance between the gauge line of a frog to the guard line <sup>1</sup> of its guard rail or guarding face, measured across the track at right angles to the gauge line, <sup>2</sup> may not be less than—	<i>Guard face gauge</i> The distance between the guard lines, <sup>1</sup> measured across the track at right angles to the gauge line, <sup>2</sup> may not be more than—
H0–H7 .....	1393 mm	1358 mm

<sup>1</sup> A line along that side of the flangeway which is nearer to the center of the track and at the same elevation as the gauge line.

<sup>2</sup> A line 14 mm (0.55 inches) below the top of the center line of the head of the running rail, or corresponding location of the tread portion of the track structure.

Figure 4 to § 299.333 – Guard Check and Guard Face Gage Measurement (Top View)

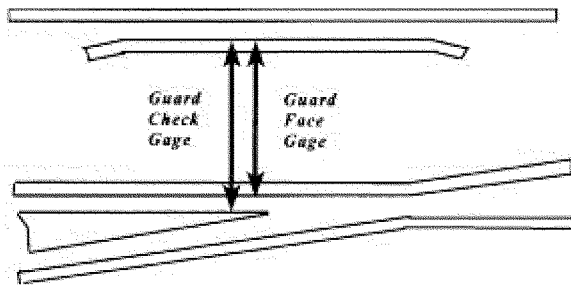
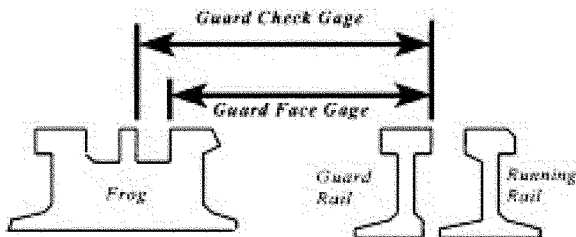

Figure 5 to § 299.333 – Guard Check and Guard Face Gage Measurement (In line with rail view)



**§ 299.335 Derails.**

(a) Derails shall be installed at locations where maintenance-of-way equipment can access track other than Class H0, in a configuration intended to derail the un-controlled equipment away from the mainline and at a distance from the point of intersection with the mainline that will not foul the dynamic envelope of the mainline.

(b) Each derail shall be clearly visible to railroad personnel operating rail equipment on the affected track and to

railroad personnel working adjacent to the affected track. When in a locked position, a derail shall be free of any lost motion that would allow it to be operated without removal of the lock.

(c) Each derail shall be maintained and function as intended.

(d) Each derail shall be properly installed for the rail to which it is applied.

(e) If a track is equipped with a derail it shall be in the derailing position except as provided in the railroad's

operating rules, special instructions, or changed to permit movement.

**§ 299.337 Automated vehicle-based inspection systems.**

(a) A qualifying Track Geometry Measurement System (TGMS) and a qualifying Track Acceleration Measurement System (TAMS) shall be operated over the route at the following frequency:



(1) For track Class H3, at least twice per calendar year with not less than 120 days between inspections; and

(2) For track Classes H4, H5, H6, and H7, at least twice within any 60-day period with not less than 12 days between inspections.

(b) The qualifying TGMS shall meet or exceed minimum design requirements which specify that—

(1) Track geometry measurements shall be taken no more than 1 meter (3.3 feet) away from the contact point of wheels carrying a vertical load of no less than 4,500 kg (10,000 lb) per wheel;

(2) Track geometry measurements shall be taken and recorded on a distance-based sampling interval not exceeding 0.60 m (2 feet), preferably 0.30 m (1 foot);

(3) Calibration procedures and parameters are assigned to the system which assures that measured and recorded values accurately represent track conditions. Track geometry measurements recorded by the system shall not differ on repeated runs at the same site at the same speed more than 3 mm ( $\frac{1}{8}$  inch); and

(4) The TGMS shall be capable of measuring and processing the necessary track geometry parameters to determine compliance with §§ 299.311 and 299.315.

(5) A qualifying TAMS shall be on a vehicle having dynamic response characteristics that are representative of other vehicles assigned to the service and shall—

(i) Be operated at the revenue speed profile in accordance with § 299.309;

(ii) Be capable of measuring and processing carbody acceleration parameters to determine compliance with Carbody Acceleration Limits per § 299.313; and

(iii) Monitor lateral and vertical accelerations of the carbody. The accelerometers shall be attached to the carbody on or under the floor of the vehicle, as near the center of a bogie as practicable.

(d) The qualifying TGMS and TAMS shall be capable of producing, within 24 hours of the inspection, output reports that—

(1) Provide a continuous plot, on a constant-distance axis, of all measured track geometry and carbody acceleration parameters required in paragraph (b) and (c) of this section;

(2) Provide an exception report containing a systematic listing of all track geometry and all acceleration conditions which constitute an exception to the class of track over the segment surveyed.

(e) The output reports required under paragraph (d) of this section shall

contain sufficient location identification information which enables field personnel to easily locate indicated exceptions.

(f) Following a track inspection performed by a qualifying TGMS or TAMS, the railroad shall, institute remedial action for all exceptions to the class of track in accordance with the railroad's inspection, testing, and maintenance program.

(g) The railroad shall maintain for a period of one year following an inspection performed by a qualifying TGMS and TAMS, a copy of the plot and the exception report for the track segment involved, and additional records which—

(1) Specify the date the inspection was made and the track segment involved; and,

(2) Specify the location, remedial action taken, and the date thereof, for all listed exceptions to the class.

#### § 299.339 Daily sweeper inspection.

A sweeper vehicle shall be operated each morning after the overnight maintenance over all tracks except track Class H2 in stations, prior to commencing revenue service over that track. The sweeper vehicle shall operate at a speed no greater than 120 km/h (75 mph) to conduct a visual inspection to ensure the right-of-way is clear of obstacles within the clearance envelope and to identify conditions that could cause accidents, and shall have a minimum clearance of no less than 35 mm above top of rail.

#### § 299.341 Inspection of rail in service.

(a) Prior to revenue service the railroad shall submit written procedures for the inspection of rails in accordance with the inspection, testing, and maintenance program.

(b) On track Classes H4 to H7, and H2 within stations, a continuous search for internal defects shall be made of all rail within 180 days after initiation of revenue service and, thereafter, at least annually, with not less than 240 days between inspections.

(c) Each defective rail shall be marked with a highly visible marking on both sides of the rail.

(d) Inspection equipment shall be capable of detecting defects between joint bars and within the area enclosed by joint bars.

(e) If the person assigned to operate the rail defect detection equipment being used determines that, due to rail surface conditions, a valid search for internal defects could not be made over a particular length of track, the test on that particular length of track cannot be

considered as a search for internal defects under this section.

(f) When the railroad learns, through inspection or otherwise, that a rail in that track contains any of the defects in accordance with § 299.321, a qualified individual designated under § 299.353 or 299.355 shall determine whether or not the track may continue in use. If the qualified individual so designated determines that the track may continue in use, operation over the defective rail is not permitted until—

(1) The rail is replaced; or

(2) The remedial action as prescribed in § 299.321 has been taken.

(g) The person assigned to operate the rail defect detection equipment must be a qualified operator as defined in this subpart and have demonstrated proficiency in the rail flaw detection process for each type of equipment the operator is assigned.

#### § 299.343 Initial inspection of new rail and welds.

(a) The railroad shall provide for the initial inspection of newly manufactured rail, and for initial inspection of new welds made in either new or used rail. The railroad may demonstrate compliance with this section by providing for—

(1) *Mill inspection.* A continuous inspection at the rail manufacturer's mill shall constitute compliance with the requirement for initial inspection of new rail, provided that the inspection equipment meets the applicable requirements as specified under the railroads inspection testing and maintenance program and § 299.321. The railroad shall obtain a copy of the manufacturer's report of inspection and retain it as a record until the rail receives its first scheduled inspection under § 299.341;

(2) *Welding plant inspection.* A continuous inspection at a welding plant, if conducted in accordance with the provisions of paragraph (a)(1) of this section, and accompanied by a plant operator's report of inspection which is retained as a record by the railroad, shall constitute compliance with the requirements for initial inspection of new rail and plant welds, or of new plant welds made in used rail; and

(3) *Inspection of field welds.* Initial inspection of new field welds, either those joining the ends of CWR strings or those made for isolated repairs, shall be conducted before the start of revenue service in accordance with the railroad's inspection, testing, and maintenance program. The initial inspection may be conducted by means of portable test equipment. The railroad shall retain a record of such inspections until the

welds receive their first scheduled inspection under § 299.341.

(b) Each defective rail found during inspections conducted under paragraph (a)(3) of this section shall be marked with highly visible markings on both sides of the rail and the appropriate remedial action as set forth in § 299.341 will apply.

**§ 299.345 Visual inspections; right of way.**

(a) *General.* All track shall be visually inspected in accordance with the schedule prescribed in paragraph (c) of this section by an individual qualified under this subpart. The visual inspection shall be conducted in accordance with the requirements set forth in the inspection, testing, and maintenance program under subpart G of this part.

(b) *Inspection types and frequency—*

(1) *Safe walkway inspection.* Except for track located inside trainset maintenance facilities and MOW yards and the associated portions of the right-of-way, the right-of-way and all track shall be inspected from the safe walkway during daytime hours, in accordance with the following conditions:

(i) Ballasted track shall be inspected at least once every two weeks, with a minimum of six calendar days in between inspections.

(ii) Non-ballasted track shall be inspected at least once every four weeks, with a minimum of twelve calendar days in between inspections.

(iii) No two consecutive visual inspections from the safe walkway shall be performed from the same safe walkway. Safe walkway inspections shall alternate between safe walkways on each side of the right-of-way.

(iv) In stations, the safe walkway inspection may be performed from either the safe walkway or the station platform.

(v) An additional on-track visual inspection conducted during maintenance hours under paragraph (b)(2) of this section performed in place of a visual inspection from the safe walkway under paragraph (b)(1) of this section will satisfy the visual inspection requirement of paragraph (b)(1) of this section. However, a safe walkway visual inspection performed under paragraph (b)(1) of this section cannot replace an on-track visual inspection conducted during maintenance hours under paragraph (b)(2) of this section.

(vi) Except for paragraph (b)(2)(v) of this section, inspections performed under paragraph (b)(1) of this section shall not occur during the same week as inspections performed under paragraph (b)(2) of this section.

(2) *On-track inspections; other than trainset maintenance facilities and MOW yards.* Except for track located inside trainset maintenance facilities and MOW yards and the associated portions of the right-of-way, on-track visual inspections, conducted on foot during maintenance hours, shall be performed on all track in accordance with the following conditions:

(i) Ballasted track shall be inspected at least once every two weeks, with a minimum of six calendar days in between inspections.

(ii) Non-ballasted track shall be inspected at least once every four weeks, with a minimum of twelve calendar days in between inspections.

(iii) Turn-outs and track crossings shall be inspected at least once a week, with a minimum of three calendar days in between inspections.

(3) *On-track inspections; trainset maintenance facilities and MOW yards.* For track located inside trainset maintenance facilities and MOW yards and the associated portions of the right-of-way, including turn-outs and track crossings, on-track visual inspections, conducted on foot during maintenance hours, shall be performed on all track in accordance with the following conditions:

(i) Ballasted track shall be inspected at least twice during any 60-day period, with a minimum of twelve calendar days in between inspections.

(ii) Non-ballasted track shall be inspected at least twice within any 120-day period, with a minimum of twenty-four calendar days in between inspections.

(4) *Visual inspections from trainset cab.* Visual inspections from trainset cab shall be performed for the right-of-way and track for track Class H3 and above, except of track leading to a trainset maintenance facility, at least twice weekly with a minimum of two calendar days between inspections.

(c) If a deviation from the requirements of this subpart is found during the visual inspection, remedial action shall be initiated immediately in accordance with the railroad's inspection, testing, and maintenance program required under subpart G of this part.

**§ 299.347 Special inspections.**

In the event of fire, flood, severe storm, temperature extremes, or other occurrence which might have damaged track structure, a special inspection shall be made of the track and right-of-way involved as soon as possible after the occurrence, prior to the operation of any trainset over that track.

**§ 299.349 Inspection records.**

(a) The railroad shall keep a record of each inspection required to be performed on that track under this subpart.

(b) Except as provided in paragraph (f) of this section, each record of an inspection under §§ 299.325 and 299.345 shall be prepared on the day the inspection is made and signed by the person making the inspection.

(c) Records shall specify the track inspected, date of inspection, location, and nature of any deviation from the requirements of this part, name of qualified individual who made the inspection, and the remedial action, if any, taken by the person making the inspection.

(d) Rail inspection records shall specify the date of inspection, the location and nature of any internal defects found, name of qualified individual who made the inspection, the remedial action taken and the date thereof, and the location of any intervals of track not tested pursuant to § 299.341 of this part. The railroad shall retain a rail inspection record for at least two years after the inspection and for one year after remedial action is taken.

(e) The railroad shall make inspection records required by this section available for inspection and copying by the FRA.

(f) For purposes of compliance with the requirements of this section, the railroad may maintain and transfer records through electronic transmission, storage, and retrieval provided that—

(1) The electronic system is compliant with the requirements of § 299.11;

(2) The electronic storage of each record shall be initiated by the person making the inspection within 24 hours following the completion of that inspection;

(3) Track inspection records shall be kept available to persons who performed the inspection and to persons performing subsequent inspections.

(g) Each track/vehicle performance record required under § 299.337 shall be made available for inspection and copying by the FRA.

**§ 299.351 Qualifications for track maintenance and inspection personnel.**

(a) *General.* The railroad shall designate qualified individuals responsible for the maintenance and inspection of track in compliance with the safety requirements prescribed in this subpart. Each designated individual, including contractors and their employees, must meet the minimum qualifications set forth in this subpart.

(b) *Recordkeeping.* In addition to the requirements contained in § 243.203 of this chapter, the railroad shall also maintain, with respect to the designation of individuals under this subpart, the track inspection records made by each individual as required by § 299.347.

**§ 299.353 Personnel qualified to supervise track restoration and renewal.**

Each individual designated to supervise restorations and renewals of track, shall have—

(a) Successfully completed a course offered by the employer or by a college level engineering program, supplemented by special on-the-job training emphasizing the techniques to be employed in the supervision, restoration, and renewal of high-speed track;

(b) Demonstrated to the railroad, at least once per calendar year, that the individual—

(1) Knows and understands the requirements of this subpart that apply to the restoration and renewal of the track for which he or she is responsible;

(2) Can detect deviations from those requirements; and,

(3) Can prescribe appropriate remedial action to correct or safely compensate for those deviations.

(c) Written authorization from the railroad or the employer to prescribe remedial actions to correct or safely compensate for deviations from the requirements of this subpart and shall have successfully completed a recorded examination on this subpart as part of the qualification process.

**§ 299.355 Personnel qualified to inspect track.**

Each individual designated to inspect track for defects, shall have—

(a) Successfully completed a course offered by the railroad or by a college level engineering program, supplemented by special on-the-job training emphasizing the techniques to be employed in the inspection of high-speed track;

(b) Demonstrated to the railroad, at least once per calendar year, that the individual—

(1) Knows and understands the requirements of this subpart that apply to the inspection of the track for which he or she is responsible;

(2) Can detect deviations from those requirements; and,

(3) Can prescribe appropriate remedial action to correct or safely compensate for those deviations.

(c) Written authorization from the railroad or the employer to prescribe remedial actions to correct or safely

compensate for deviations from the requirements in this subpart and shall have successfully completed a recorded examination on this subpart as part of the qualification process.

**§ 299.357 Personnel qualified to inspect and restore continuous welded rail.**

Individuals designated under § 299.353 or 299.355 that inspect continuous welded rail (CWR) or supervise the installation, adjustment, and maintenance of CWR in accordance with the written procedures established by the railroad shall have—

(a) Current qualifications under either § 299.353 or 299.355;

(b) Successfully completed a training course of at least eight hours duration specifically developed for the application of written CWR procedures issued by the railroad;

(c) Demonstrated to the railroad that the individual—

(1) Knows and understands the requirements of those written CWR procedures;

(2) Can detect deviations from those requirements;

(3) Can prescribe appropriate remedial action to correct or safely compensate for those deviations.

(d) Written authorization from the railroad or the employer to prescribe remedial actions to correct or safely compensate for deviations from the requirements in those procedures and must have successfully completed a recorded examination on those procedures as part of the qualification process. The recorded examination may be written, or in the form of a computer file with the results of an interactive training course.

**Subpart D—Rolling Stock**

**§ 299.401 Clearance requirements.**

(a) *General.* The rolling stock shall be designed to meet all applicable clearance requirements of the railroad. The railroad shall make its clearance diagrams available to FRA upon request.

(b) *Clearance above top of rail.* No part or appliance of a trainset except the wheels, sander tips, wheel guards, and other components designed to be in the path of the wheel (*i.e.*, above the rail and aligned inside the wheel width path) may be less than 60 mm (2.36 inches) above the top of rail.

(c) *Obstacle deflector.* The leading end of a trainset shall be equipped with an obstacle deflector that extends across both rails of the track. The minimum clearance above the rail of the obstacle deflector shall be 76 mm (3 inches), and the maximum clearance shall be 229 mm (9 inches).

(d) *Flexible wheel guards.* The lead axle of a trainset shall be equipped with flexible wheel guards mounted on the bogie below the primary suspension with a maximum clearance above the rail of 15 mm (0.59 inches).

**§ 299.403 Trainset structure.**

(a) *Occupied volume integrity.* To demonstrate resistance to loss of occupied volume, the trainsets shall comply with both the compression load requirement in paragraph (b) of this section and the dynamic collision requirements in paragraph (c) of this section.

(b) *Compression load requirement.* The end compression load shall be applied to the vehicle as defined in JIS E 7105:2006 as amended by JIS E 7105:2011 (all incorporated by reference, see § 299.17), with an end load magnitude no less than 980 kN (220,300 lbf) without permanent deformation of the occupied volume.

(c) *Dynamic collision scenario.* In addition to the requirements of paragraph (b) of this section, occupied volume integrity shall also be demonstrated for the trainset through an evaluation of a dynamic collision scenario in which a moving trainset impacts a proxy object under the following conditions:

(1) The initially-moving trainset is made up of the equipment undergoing evaluation at its AW0 ready-to-run weight;

(2) The scenario shall be evaluated on tangent, level track;

(3) The trainset shall have an initial velocity of 32 km/h (20 mph) and shall not be braked;

(4) The proxy object shall have the following characteristics:

(i) The object shall be a solid circular cylinder that weighs 6350 kg (14,000 pounds);

(ii) The object shall have a width of 914 mm (36 inches) and a diameter of 1219 mm (48 inches);

(iii) The axis of the cylinder shall be perpendicular to the direction of trainset motion and parallel to the ground; and

(iv) The center of the object shall be located 762 mm (30 inches) above the top of the underframe.

(5) *Collision configurations.* Two collision configurations shall be evaluated.

(i) The center of the object shall be located 483 mm (19 inches) from the longitudinal centerline of the trainset; and

(ii) The center of the object shall be aligned with the side of the cab car at the point of maximum width.

(6) *Model validation.* The model used to demonstrate compliance with the

dynamic collision requirements must be validated. Model validation shall be demonstrated and submitted to FRA for review and approval.

(7) *Dynamic collision requirements.* As a result of the impact described in paragraphs (c)(5)(i) and (ii) of this section—

(i) One of the following two conditions must be met for the occupied volume:

(A) There shall be no more than 254 mm (10 inches) of longitudinal permanent deformation; or

(B) Global vehicle shortening shall not exceed 1 percent over any 4.6 m (15-foot) length of occupied volume.

(ii) Compliance with each of the following conditions shall also be demonstrated for the cab after the impact:

(A) Each seat provided for an employee regularly assigned to occupy the cab, and any floor-mounted seat in the cab, shall maintain a survival space where there is no intrusion for a minimum of 305 mm (12 inches) from each edge of the seat. Walls or other items originally within this defined space shall not further intrude more than 38 mm (1.5 inches) towards the seat under evaluation.

(B) There shall be a clear exit path for the occupants of the cab;

(C) The vertical height of the cab (floor to ceiling) shall not be reduced by more than 20 percent; and

(D) The operating console shall not have moved closer to the driver's seat by more than 51 mm (2 inches).

(d) *Equipment override.* (1) Using the dynamic collision scenarios described in paragraph (c) of this section, and with all units in the trainset are positioned at their nominal running heights, the anti-climbing performance shall be evaluated for each of the following sets of initial conditions:

(2) For the initial conditions specified in paragraphs (c)(1) through (3) of this section, compliance with the following conditions shall be demonstrated after a dynamic impact:

(i) The relative difference in elevation between the underframes of the connected equipment shall not change by more than 102 mm (4 inches); and

(ii) The tread of any wheel of the trainset shall not rise above the top of rail by more than 102 mm (4 inches).

(e) *Roof and side structure integrity.* To demonstrate roof and side structure integrity, each passenger car shall comply with the following:

(1) *Rollover strength.* (i) Each passenger car shall be designed to rest on its side and be uniformly supported

at the top and bottom cords of the vehicle side. The allowable stress in the structural members of the occupied volumes for this condition shall be one-half yield or one-half the critical buckling stress, whichever is less. Local yielding to the outer skin of the passenger car is allowed provided that the resulting deformations in no way intrude upon the occupied volume of the car.

(ii) Each passenger car shall also be designed to rest on its roof so that any damage in occupied areas is limited to roof extrusions. Other than roof extrusions, the allowable stress in the structural members of the occupied volumes for this condition shall be one-half yield or one-half the critical buckling stress, whichever is less. Local yielding to the outer skin, including the floor structure, of the car is allowed provided that the resulting deformations in no way intrude upon the occupied volume of the car. Deformation to the roof extrusions is allowed to the extent necessary to permit the vehicle to be supported directly on the top chords of the sides and ends.

(2) *Side structure.* (i) The sum of the section moduli about a longitudinal axis, taken at the weakest horizontal section between the side sill and roof, of the extrusions on each side of the car located between the inside edge of the doors shall be not less than 3.95x10<sup>5</sup> mm<sup>3</sup> (24.1 in<sup>3</sup>).

(ii) The sum of the section moduli about a transverse axis, taken at the weakest horizontal section on each side of the car located between body corners shall be not less than 2.64x10<sup>5</sup> mm<sup>3</sup> (16.1 in<sup>3</sup>).

(iii) The minimum section moduli or thicknesses specified in paragraph (f)(2)(i) of this section shall be adjusted in proportion to the ratio of the yield strength of the material used to a value of 172 MPa (25 ksi).

(iv) The combined thickness of the skin of the side structure extrusions shall not be less than 3 mm (0.125 inch) nominal thickness. The thicknesses shall be adjusted in proportion to the ratio of the yield strength of the material used to a value of 172 MPa (25 ksi).

(f) *Bogie-to-carbody attachment.* (1) The bogie-to-carbody attachment shall utilize the service proven design as used on the N700.

(2) The bogie shall be securely attached to the carbody and designed to operate without failure under the operating conditions of the railroad, including expected mechanical shocks and vibrations.

#### § 299.405 Trainset interiors.

(a) *Interior fittings.* Interior fittings of trainsets shall be—

(1) Securely attached and designed to operate without failure under the conditions typically found in passenger rail equipment including expected mechanical vibrations, and shock.

(2) To the extent possible, all interior fittings shall be recessed or flush mounted. Corners and/or sharp edges shall be either avoided or padded to mitigate the consequence of impact with such surfaces.

(b) *Luggage stowage.* (1) Luggage stowage racks shall slope downward in the outboard direction at a minimum ratio of 1:8 with respect to a horizontal plane to provide lateral restraint for stowed articles.

(2) Luggage stowage compartments shall provide longitudinal restraint for stowed articles.

#### § 299.407 Glazing.

(a) *General.* The railroad shall install glazing systems compliant with the requirements defined in this section.

(b) *Trainset glazing; end-facing.* (1) Each end-facing exterior window of the trainset shall comply with the requirements for large object and ballistic impact scenarios as defined in this section.

(2) Each end-facing exterior window of the trainset shall demonstrate compliance with the following requirements for the large object impact test.

(i) The glazing article shall be impacted with a cylindrical projectile that complies with the following design specifications as depicted in Figure 6 to paragraph (b)(2)(i)(D) of this section:

(A) The projectile shall be constructed of aluminum alloy such as ISO 6362-2:1990, grade 2017A, or its demonstrated equivalent;

(B) The projectile end cap shall be made of steel;

(C) The projectile assembly shall weigh 1 kilogram (kg) (−0, +0.020 kg) or 2.2 lbs (−0, +0.044 lbs) and shall have a hemispherical tip. Material may be removed from the interior of the aluminum portion to adjust the projectile mass according to the prescribed tolerance. The hemispherical tip shall have a milled surface with 1 mm (0.04 inches) grooves; and

(D) The projectile shall have an overall diameter of 94 mm (3.7 inches) with a nominal internal diameter of 70 mm (2.76 inches).

Figure 6 to paragraph (b)(2)(i)(D) - Large Object Glazing Test Projectile

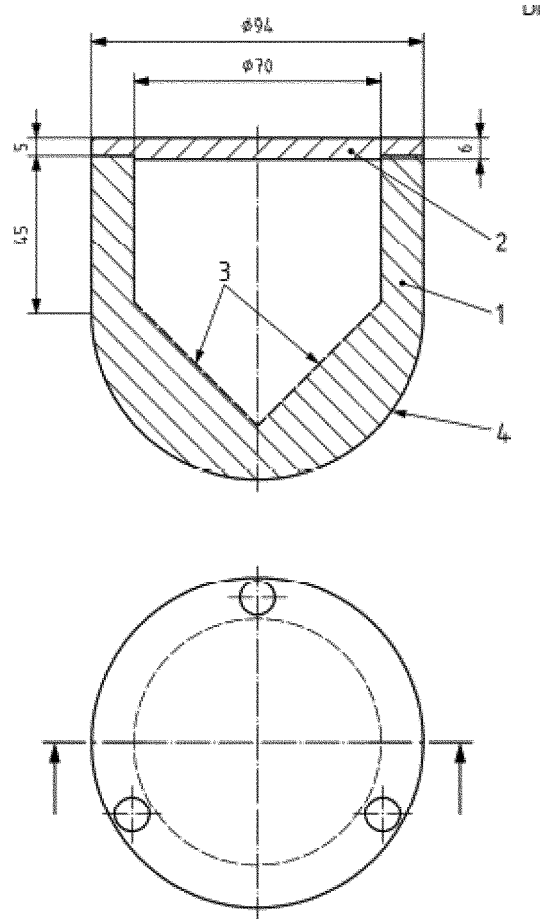
**Key**

- 1 projectile in aluminium alloy (ISO 6362-2:1990, grade 2017A)
- 2 steel projectile cover
- 3 material may be removed for adjustment purposes
- 4 milled surface of hemispheric tip (1 mm)

(ii) The test of the glazing article shall be deemed satisfactory if the test projectile does not penetrate the glazing article, the glazing article remains in its frame, and the witness plate is not marked by spall.

(iii) A new projectile shall be used for each test.

(iv) The glazing article to be tested shall be that which has the smallest area for each design type. For the test, the glazing article shall be fixed in a frame of the same construction as that mounted on the vehicle.

(v) A minimum of four tests shall be conducted and all must be deemed satisfactory. Two tests shall be conducted with the complete glazing article at  $0^{\circ}\text{C} \pm 0.5^{\circ}\text{C}$  ( $32^{\circ}\text{F} \pm 0.9^{\circ}\text{F}$ ) and two tests shall be conducted with the complete glazing article at  $20^{\circ}\text{C} \pm 5^{\circ}\text{C}$  ( $68^{\circ}\text{F} \pm 9^{\circ}\text{F}$ ). For the tests to be valid it shall be demonstrated that the core temperature of the complete glazing

article during each test is within the required temperature range.

(vi) The test glazing article shall be mounted at the same angle relative to the projectile path as it will be to the direction of travel when mounted on the vehicle.

(vii) The projectile's impact velocity shall equal the maximum operating speed of the trainset plus 160 km/h (100 mph). The projectile velocity shall be measured within 4 m (13 feet) of the point of impact.

(viii) The point of impact shall be at the geometrical center of the glazing article.

(3) Representative samples for large object impact testing of large end-facing cab glazing articles may be used, instead of the actual design size provided that the following conditions are met:

(i) Testing of glazing articles having dimensions greater than 1,000 mm by 700 mm (39.4 by 27.6 inches), excluding

framing, may be performed using a flat sample having the same composition as the glazing article for which compliance is to be demonstrated. The glazing manufacturer shall provide documentation containing its technical justification that testing a flat sample is sufficient to verify compliance of the glazing article with the requirements of this paragraph.

(ii) Flat sample testing is permitted only if no surface of the full-size glazing article contains curvature whose radius is less than 2,500 mm (98 inches); and when a complete, finished, glazing article is laid (convex side uppermost) on a flat horizontal surface, the distance, (measured perpendicularly to the flat surface) between the flat surface and the inside face of the glazing article is not greater than 200 mm (8 inches).

(4) End-facing glazing shall demonstrate sufficient resistance to spalling, as verified by the large impact

projectile test under the following conditions:

(i) An annealed aluminum witness plate of maximum thickness 0.15 mm (0.006 inches) and of dimension 500 mm by 500 mm (19.7 by 19.7 inches) is placed vertically behind the sample under test, at a horizontal distance of 500 mm (19.7 inches) from the point of impact in the direction of travel of the projectile or the distance between the point of impact of the projectile and the location of the driver's eyes in the driver's normal operating position, whichever is less. The center of the witness plate is aligned with the point of impact.

(ii) Spalling performance shall be deemed satisfactory if the aluminum witness plate is not marked.

(iii) For the purposes of this part, materials used specifically to protect the cab occupants from spall (*i.e.*, spall shields) shall not be required to meet the flammability and smoke emission performance requirements of § 299.413.

(5) Each end-facing exterior window in a cab shall, at a minimum, provide ballistic penetration resistance that meets the requirements of appendix A to part 223 of this chapter.

(c) *Trainset glazing; side-facing.* Except as provided in paragraph (d) of this section, each side-facing exterior window in a trainset shall comply with the requirements for Type II glazing as defined in part 223 of this chapter or other alternative standard approved by FRA.

(d) *Side-facing breakable glazing.* A side-facing exterior window intended to be breakable and serve as an emergency window exit may comply with an alternative standard approved for use by FRA under § 299.15.

(e) *Certification of Glazing Materials.* Glazing materials shall be certified in accordance with the following procedures:

(1) Each manufacturer that provides glazing materials, intended by the manufacturer for use in achieving compliance with the requirements of this subpart, shall certify that each type of glazing material being supplied for this purpose has been successfully tested in accordance with this section and that test verification data are available to the railroad or to FRA upon request.

(2) Tests performed on glazing materials for compliance with this part shall be conducted by either—

(i) An independent third party (lab, facility, underwriter); or  
 (ii) The glazing manufacturer, providing FRA with the opportunity to witness all tests by written notice, a minimum of 30 days prior to testing.

(3) Any glazing material certified to meet the requirements of this part shall be re-certified if any change is made to the glazing that may affect its mechanical properties or its mounting arrangement on the vehicle.

(4) All certification/re-certification documentation shall be made available to FRA upon request. The test verification data shall contain all pertinent original data logs and documentation that the selection of material samples, test set-ups, test measuring devices, and test procedures were performed by qualified individuals using recognized and acceptable practices and in accordance with this section.

(5) Glazing shall be marked in the following manner:

(i) Each end-facing exterior window in a cab shall be permanently marked, prior to installation, in such a manner that the marking is clearly visible after the material has been installed. The marking shall include:

(A) The words "FRA TYPE IHS" to indicate that the material meets the requirements specified in paragraph (b) of this section;

(B) The manufacturer of the material; and

(C) The type or brand identification of the material.

(ii) Each side-facing exterior window in a trainset shall be permanently marked, prior to installation, in such a manner that the marking is clearly visible after the material has been installed. The marking shall include:

(A) The words "FRA TYPE II" to indicate that the material meets the requirements specified in paragraph (c) of this section;

(B) The manufacturer of the material; and

(C) The type or brand identification of the material.

(f) *Glazing securement.* Each exterior window shall remain in place when subjected to—

(1) The forces due to air pressure differences caused when two trainsets pass at the minimum separation for two adjacent tracks, while traveling in opposite directions, each trainset traveling at the maximum approved trainset speed in accordance with § 299.609(g); and

(2) The impact forces that the exterior window is required to resist as specified in this section.

#### § 299.409 Brake system.

(a) *General.* The railroad shall demonstrate through analysis and testing the maximum safe operating speed for its trainsets that results in no thermal damage to equipment or

infrastructure during normal operation of the brake system.

(b) *Minimum performance requirement for brake system.* Each trainset's brake system, under the worst-case adhesion conditions as defined by the railroad, shall be capable of stopping the trainset from its maximum operating speed within the signal spacing existing on the track over which the trainset is operating.

(c) *Urgent brake system.* A trainset shall be provided with an urgent brake application feature that produces an irretrievable stop. An urgent brake application shall be available at any time, and shall be initiated by an unintentional parting of the trainset or by the trainset crew from the conductor rooms.

(d) *Application/release indication.* The brake system shall be designed so that an inspector may determine whether the brake system is functioning properly without being placed in a dangerous position on, under or between the equipment. This determination may be made through automated monitoring system that utilizes sensors to verify that the brakes have been applied and released.

(e) *Passenger brake alarm.* (1) A means to initiate a passenger brake alarm shall be provided at two locations in each unit of a trainset. The words "Passenger Brake Alarm" shall be legibly stenciled or marked on each device or on an adjacent badge plate.

(2) All passenger brake alarms shall be installed so as to prevent accidental activation.

(3) When a passenger brake alarm is activated, it shall initiate an emergency brake application. The emergency brake application can be overridden by the driver so that the trainset can be stopped at a safe location.

(4) To retrieve the emergency brake application described in paragraph (e)(3) of this section, the driver must activate appropriate controls to issue a command for brake application as specified in the railroad's operating rules.

(f) *Degraded brake system performance.* The following requirements address degraded brake system performance on the railroad's high-speed trainsets—

(1) Loss of power or failure of regenerative brake shall not result in exceeding the allowable stopping distance as defined by the railroad;

(2) The available friction braking shall be adequate to stop the trainset safely under the operating conditions defined by the railroad;

(3) The operational status of the trainset brake system shall be displayed for the driver in the operating cab; and

(4) Under § 299.607(b)(5), the railroad shall demonstrate through analysis and testing the maximum speed for safely operating its trainsets using only the friction brake system with no thermal damage to equipment or infrastructure. The analysis and testing shall also determine the maximum safe operating speed for various percentages of operative friction brakes.

(g) *Main reservoir system.* The main reservoirs in a trainset shall be designed and tested to meet the requirements set forth in JIS B 8265 (incorporated by reference, see § 299.17). Reservoirs shall be certified based on their size and volume requirements.

(h) *Main reservoir tests.* Prior to initial installation, each main reservoir shall be subjected to a pneumatic or hydrostatic pressure test based on the maximum working pressure defined in paragraph (g) of this section unless otherwise established by the railroad's mechanical officer. Records of the test date, location, and pressure shall be maintained by the railroad for the life of the equipment. Periodic inspection requirements for main reservoirs shall be defined in the railroad's inspection, testing, and maintenance program required by § 299.445.

(i) *Brake gauges.* All mechanical gauges and all devices providing electronic indication of air pressure that are used by the driver to aid in the control or braking of a trainset shall be located so that they can be conveniently read from the driver's normal position during operation of the trainset.

(j) *Brake application/release.* (1) Brake actuators shall be designed to provide brake pad clearance when the brakes are released.

(2) The minimum brake cylinder pressure shall be established to provide adequate adjustment from minimum service to emergency for proper trainset operation.

(k) *Leakage.* The method of inspection for main reservoir pipe and brake cylinder pipe leakage shall be prescribed in the railroad's inspection, testing, and maintenance program required by § 299.445.

(l) *Slide alarm.* (1) A trainset shall be equipped with an adhesion control system designed to automatically adjust the braking force on each wheel to prevent sliding during braking.

(2) A wheel slide alarm that is visual or audible, or both, shall alert the driver in the operating cab to wheel-slide conditions on any axle of the trainset.

(3) Operating restrictions for a trainset with wheel slide protection devices that

are not functioning as intended shall be defined by the railroad under its requirements for movement of defective equipment required by § 299.447, and within the railroad's operating rules, as appropriate.

(m) *Monitoring and diagnostic system.* Each trainset shall be equipped with a monitoring and diagnostic system that is designed to automatically assess the functionality of the brake system for the entire trainset. Details of the system operation and the method of communication of brake system functionality prior to the dispatch of the trainset shall be described in detail in the railroad's Operating Rules and inspection, testing, and maintenance program required by § 299.445.

(n) *Trainset securement.* Each trainset shall be equipped with a means of securing the equipment, independent of the friction brake, on the grade condition defined by the railroad. The railroad's operating rules shall define procedures for trainset securement and the railroad shall demonstrate that these procedures effectively secure the equipment in accordance with § 299.607(b)(5).

(o) *Rescue operation; brake system.* A trainset's brake system shall be designed so as to allow a rescue vehicle or trainset to control its brakes when the trainset is disabled.

#### § 299.411 Bogies and suspension system.

(a) *Wheel climb.* (1) Suspension systems shall be designed to reasonably prevent wheel climb, wheel unloading, rail rollover, rail shift, and a vehicle from overturning to ensure safe, stable performance and ride quality. These requirements shall be met—

(i) In all operating environments, and under all track conditions and loading conditions as determined by the railroad; and

(ii) At all track speeds and over all track qualities consistent with the requirements in subpart C of this part, up to the maximum trainset speed and maximum cant deficiency of the equipment in accordance with § 299.609(g).

(2) All passenger equipment shall meet the safety performance standards for suspension systems contained in § 299.609(h). In particular—

(i) *Vehicle/track system qualification.* All trainsets shall demonstrate safe operation during pre-revenue service qualification in accordance with § 299.609 and is subject to the requirements of § 299.313.

(ii) *Revenue service operation.* All passenger equipment in service is subject to the requirements of § 299.313.

(b) *Lateral accelerations.* The trainsets shall not operate under conditions that result in a steady-state lateral acceleration greater than 0.15g, as measured parallel to the car floor inside the passenger compartment.

(c) *Journal bearing overheat sensors.* Bearing overheat sensors shall be provided on all journal bearings on each trainset.

#### § 299.413 Fire safety.

(a) *General.* All materials used in constructing the interior of the trainset shall meet the flammability and smoke emission characteristics and testing standards contained in appendix B to part 238 of this chapter. For purposes of this section, the interior of the trainset includes walls, floors, ceilings, seats, doors, windows, electrical conduits, air ducts, and any other internal equipment.

(b) *Certification.* The railroad shall require certification that a representative sample of combustible materials to be—

(1) Used in constructing a passenger car or a cab, or

(2) Introduced in a passenger car or a cab, as part of any kind of rebuild, refurbishment, or overhaul of the car or cab, has been tested by a recognized independent testing laboratory and that the results show the representative sample complies with the requirements of paragraph (a) of this section at the time it was tested.

(c) *Fire safety analysis.* The railroad shall ensure that fire safety considerations and features in the design of the trainsets reduce the risk of personal injury caused by fire to an acceptable level in its operating environment using a formal safety methodology. To this end, the railroad shall complete a written fire safety analysis for the passenger equipment being procured. In conducting the analysis, the railroad shall—

(1) Identify, analyze, and prioritize the fire hazards inherent in the design of the equipment.

(2) Take effective steps to design the equipment and select materials which help provide sufficient fire resistance to reasonably ensure adequate time to detect a fire and safely evacuate the passengers and crewmembers, if a fire cannot be prevented. Factors to consider include potential ignition sources; the type, quantity, and location of the materials; and availability of rapid and safe egress to the exterior of the equipment under conditions secure from fire, smoke, and other hazards.

(3) Reasonably ensure that a ventilation system in the equipment

does not contribute to the lethality of a fire.

(4) Identify in writing any trainset component that is a risk of initiating fire and which requires overheat protection. An overheat detector shall be installed in any component when the analysis determines that an overheat detector is necessary.

(5) Identify in writing any unoccupied trainset compartment that contains equipment or material that poses a fire hazard, and analyze the benefit provided by including a fire or smoke detection system in each compartment so identified. A fire or smoke detector shall be installed in any unoccupied compartment when the analysis determines that such equipment is necessary to ensure sufficient time for the safe evacuation of passengers and crewmembers from the trainset. For purposes of this section, an unoccupied trainset compartment means any part of the equipment structure that is not normally occupied during operation of the trainset, including a closet, baggage compartment, food pantry, etc.

(6) Determine whether any occupied or unoccupied space requires a portable fire extinguisher and, if so, the proper type and size of the fire extinguisher for each location. As required by § 239.101 of this chapter, each passenger car is required to have a minimum of one portable fire extinguisher. If the analysis performed indicates that one or more additional portable fire extinguishers are needed, such shall be installed.

(7) Analyze the benefit provided by including a fixed, automatic fire-suppression system in any unoccupied trainset compartment that contains equipment or material that poses a fire hazard, and determine the proper type and size of the automatic fire-suppression system for each such location. A fixed, automatic fire-suppression system shall be installed in any unoccupied compartment when the analysis determines that such equipment is practical and necessary to ensure sufficient time for the safe evacuation of passengers and crewmembers from the trainset.

(8) Explain how safety issues are resolved in the design of the equipment and selection of materials to reduce the risk of each fire hazard.

(9) Describe the analysis and testing necessary to demonstrate that the fire protection approach taken in the design of the equipment and selection of materials meets the fire protection requirements of this part.

(d) *Inspection, testing, and maintenance.* The railroad shall develop and adopt written procedures for the inspection, testing, and maintenance of

all fire safety systems and fire safety equipment on the passenger equipment it operates under § 299.445(b), and subpart G of this part. The railroad shall comply with those procedures that it designates as mandatory for the safety of the equipment and its occupants.

#### § 299.415 Doors.

(a) Each powered, exterior side door in a vestibule that is partitioned from the passenger compartment of a trainset shall have a manual override device that is—

(1) Capable of releasing the door to permit it to be opened without power.

(2) Located such that—

(i) Interior access is provided adjacent to each manual door release mechanism; and,

(ii) Exterior access is provided on each side of each car.

(3) Designed and maintained so that a person may readily access and operate the override device without requiring the use of a tool or other implement.

(4) The railroad may protect a manual override device used to open a powered, exterior door with a cover or a screen.

(5) When a manual override device is activated, door panel friction, including seals and hangers, shall allow the doors to be opened or closed manually with as low a force as practicable.

(6) The emergency release mechanism shall require manual reset.

(b) Each passenger car shall have a minimum of one exterior side door per side. Each such door shall provide a minimum clear opening with dimensions of 813 mm (32 inches) horizontally by 1850 mm (72.8 inches) vertically.

(c) Door exits shall be marked, and instructions provided for their use, as specified in § 299.423.

(d) All doors intended for access by emergency responders shall be marked, and instructions provided for their use, as specified in § 299.423.

(e) Vestibule doors and other interior doors intended for passage through a passenger car.

(1) *General.* Except for a door providing access to a control compartment each powered vestibule door and any other powered interior door intended for passage through a passenger car shall have a manual override device that conforms with the requirements of paragraphs (e)(2) and (3) of this section.

(2) *Manual override devices.* Each manual override device shall be:

(i) Capable of releasing the door to permit it to be opened without power;

(ii) Located adjacent to the door it controls; and

(iii) Designed and maintained so that a person may readily access and operate

the override device from each side of the door without the use of a tool or other implement.

(3) *Marking and instructions.* Each manual override device and each retention mechanism shall be marked, and instructions provided for their use, as specified in § 299.423.

(f) The status of each powered, exterior side door in a passenger car shall be displayed to the driver in the operating cab. Door interlock sensors shall be provided to detect trainset motion and shall be nominally set to operate at 5 km/h.

(g) All powered exterior side passenger doors shall:

(1) Be equipped with the service-proven door safety system utilized by the N700 or an alternate door safety system designed subject to a Failure Modes, Effects, Criticality Analysis (FMECA);

(2) Be designed with an obstruction detection system capable of detecting a rigid flat bar, 6.4 mm (¼ inches) wide and 76 mm (3 inches) high and a rigid rod, 9.5 mm (⅜ inches) in diameter;

(3) Incorporate an obstruction detection system sufficient to detect large obstructions;

(4) Be designed so that activation of a door by-pass feature does not affect the operation of the obstruction detection system on all the other doors on the trainset;

(5) The door control station shall be located in a secured area that is only accessible to crewmembers or maintenance personnel;

(6) The door open or closed circuit shall not be affected by the throttle position; and,

(7) Discrete, dedicated trainlines shall be used for door-open and door-close commands, door-closed summary circuit, and no motion, if trainlined.

(h) All powered exterior side door systems in a trainset shall:

(1) Be designed with a door summary circuit. The door summary circuit shall be connected or interlocked to prohibit the trainset from developing tractive power if an exterior side door in a passenger car, other than a door under the direct physical control of a crewmember for his or her exclusive use, is not closed;

(2) Be connected to side door status indicators located on the exterior of each unit of the trainset;

(3) Be connected to a door summary status indicator that is readily viewable to the driver from his or her normal position in the operating cab;

(4) If equipped with a trainset-wide door by-pass device, be designed so that the trainset-wide door by-pass functions



only when activated from the operating cab of the trainset;

(5) A lock (cut-out/lock-out) mechanism shall be installed at each door panel to secure a door in the closed and locked position. When the lock mechanism is utilized to secure the door in the closed position, a door-closed indication shall be provided to the door summary circuit; and,

(6) A crew key or other secure device shall be required to lock-out an exterior side door to prevent unauthorized use.

(i)(1) *Visual inspections and functional tests.* The inspection and functional tests required for the door safety system, including the trainset-wide by-pass verification, shall be conducted in accordance with the railroad's trainset inspection, testing, and maintenance program in accordance with § 299.445, and operating rules under subpart E.

(2) *Face-to-face relief.* Crewmembers taking control of a trainset do not need to perform a visual inspection or a functional test of the door by-pass devices in cases of face-to-face relief of another trainset crew and notification by that crew as to the functioning of the door by-pass devices.

(j) The railroad shall maintain a record of each door by-pass activation and each unintended opening of a powered exterior side door, including any repair(s) made, in the defect tracking system as required by § 299.445(h).

#### § 299.417 Emergency lighting.

(a) *General.* Emergency lighting shall be provided in each unit of a trainset. The emergency lighting system shall be designed to facilitate the ability of passengers and trainset crew members, and/or emergency responders to see and orient themselves, to identify obstacles, in order to assist them to safely move through and out of a passenger rail car.

(1) Emergency lighting shall illuminate the following areas:

(i) Passenger car aisles, passageways, and toilets;

(ii) Door emergency exit controls/manual releases;

(iii) Vestibule floor near the door emergency exits (to facilitate safe entrance/exit from the door);

(iv) Within the car diaphragm and adjacent area; and

(v) Specialty car locations such as crew offices.

(b) *Minimum illumination levels.* (1) A minimum, average illumination level of 10.7 lux (1 foot-candle) measured at floor level adjacent to each exterior door and each interior door providing access to an exterior door (such as a door opening into a vestibule);

(2) A minimum, average illumination level of 10.7 lux (1 foot-candle) measured 635 mm (25 inches) above floor level along the center of each aisle and passageway;

(3) A minimum illumination level of 1.1 lux (0.1 foot-candle) measured 635 mm (25 inches) above floor level at any point along the center of each aisle and passageway;

(c) *Lighting activation.* Each emergency lighting fixture shall activate automatically or be energized continuously whenever the car is in revenue service and normal lighting is not available.

(d) *Independent power source.* Emergency lighting system shall have an independent power source(s) that is located in or within one half a car length of each light fixture it powers.

(e) *Functional requirements.* Emergency lighting system components shall be designed to operate without failure and capable of remaining attached under the conditions typically found in passenger rail equipment including expected mechanical vibrations, and shock in accordance with § 299.405(a)(1), as well as comply with electromagnetic interference criteria in § 299.435(e).

(1) All emergency lighting system components shall be capable to operate in all railcar orientations.

(2) All emergency lighting system components shall be capable to operate when normal power is unavailable for 90 minutes without a loss of more than 40% of the minimum illumination levels specified in paragraph (b) of this section.

(f) *Inspection.* (1) The railroad shall inspect the emergency lighting system as required by its inspection, testing, and maintenance program in accordance with § 299.445.

(2) If batteries are used as independent power sources, they shall have automatic self-diagnostic modules designed to perform discharge tests.

#### § 299.419 Emergency communication.

(a) *PA (public address) system.* Each passenger car shall be equipped with a PA system that provides a means for a trainset crewmember to communicate by voice to passengers of his or her trainset in an emergency situation. The PA system shall also provide a means for a trainset crewmember to communicate by voice in an emergency situation to persons in the immediate vicinity of his or her trainset (e.g., persons on the station platform). The PA system may be part of the same system as the intercom system.

(b) *Intercom system.* Each passenger car shall be equipped with an intercom

system that provides a means for passengers and crewmembers to communicate by voice with each other in an emergency situation. Except as further specified, at least one intercom that is accessible to passengers without using a tool or other implement shall be located in each end (half) of each car.

(c) *Marking and instructions.* The following requirements apply to all units of a trainset:

(1) The location of each intercom intended for passenger use shall be conspicuously marked with HPPL material in accordance with § 299.423; and

(2) Legible and understandable operating instructions shall be made of HPPL material in accordance with § 299.423 and posted at or near each such intercom.

(d) *Back-up power.* PA and intercom systems shall have a back-up power system capable of—

(1) Powering each system to allow intermittent emergency communication for a minimum period of 90 minutes. Intermittent communication shall be considered equivalent to continuous communication during the last 15 minutes of the 90-minute minimum period; and

(2) Operating in all equipment orientations within 90 degrees of vertical.

(e) *Additional requirements.* The PA and intercom systems shall be designed to operate without failure and remain attached under the conditions typically found in passenger rail equipment including expected mechanical vibrations, and shock in accordance with § 299.405(a)(1), as well as comply with electromagnetic interference criteria in § 299.435(e).

#### § 299.421 Emergency roof access.

(a) *Number and dimensions.* Each passenger car shall have a minimum of two emergency roof access locations, each providing a minimum opening of 660 mm (26 inches) longitudinally (i.e., parallel to the longitudinal axis of the car) by 610 mm (24 inches) laterally.

(b) *Means of access.* Emergency roof access shall be provided by means of a conspicuously marked structural weak point in the roof for access by properly equipped emergency response personnel.

(c) *Location.* Emergency roof access locations shall be situated so that when a car is on its side—

(1) One emergency access location is situated as close as practicable within each half of the roof as divided top from bottom; and

(2) One emergency access location is situated as close as practicable within

each half of the roof as divided left from right. (See Figure 2 to this paragraph.)

Figure 7 to paragraph (c)(2) - Example of Location of Emergency Roof Access

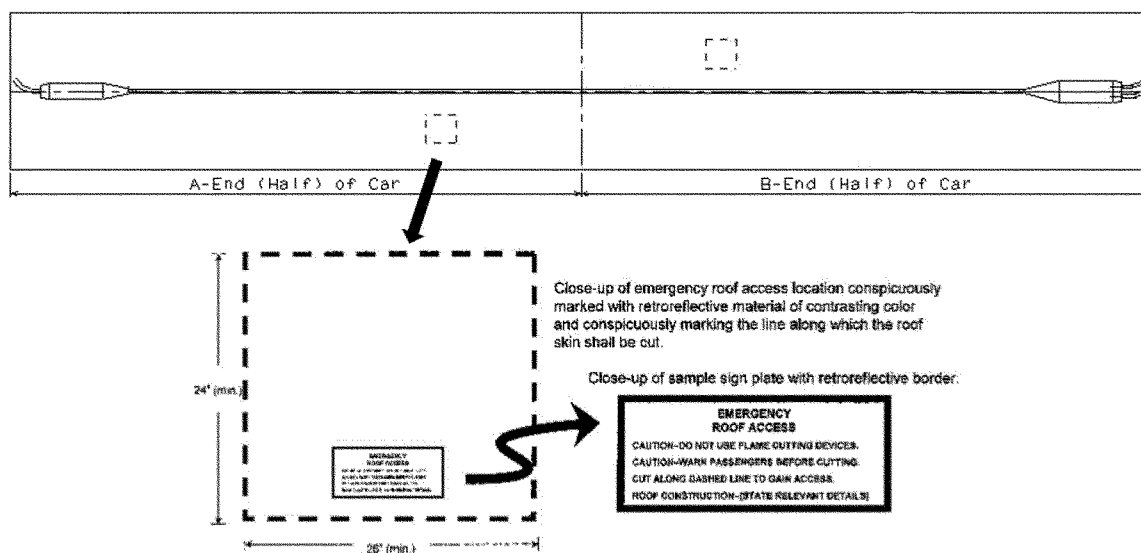

(d) *Obstructions.* The ceiling space below each emergency roof access location shall be free from wire, cabling, conduit, and piping. This space shall also be free of any rigid secondary structure (e.g., a diffuser or diffuser support, lighting back fixture, mounted PA equipment, or luggage rack) where practicable. It shall be permissible to cut through interior panels, liners, or other non-rigid secondary structures after making the cutout hole in the roof, provided any such additional cutting necessary to access the interior of the vehicle permits a minimum opening of the dimensions specified in paragraph (a) of this section to be maintained.

(e) *Marking instructions.* Each emergency roof access location shall be conspicuously marked with retroreflective material of contrasting color meeting the minimum requirements specified in § 299.423. Legible and understandable instructions shall be posted at or near each such location.

**§ 299.423 Markings and instructions for emergency egress and rescue access.**

(a) *General.* Instructions and markings shall be provided in each unit of a trainset in accordance with the minimum requirements of this section to provide instructions for passengers and trainset crewmembers for regarding emergency egress, and rescue access instructions for emergency responders.

(b) *Visual identity and recognition.* Emergency exit signage/markings systems shall enable passengers and

trainset crewmembers to make positive identification of emergency exits.

(1) Each interior emergency exit sign and emergency exit locator sign shall be conspicuous (i.e., clearly recognizable/distinguishable) or become conspicuous to passengers and trainset crewmembers immediately and automatically upon the loss of power for normal lighting, from a minimum distance of 1.52 m (5 feet).

(2) The signs and markings shall operate independently of the car's normal and emergency lighting systems, for a minimum of 90 minutes after loss of all power for normal lighting.

(3) An emergency exit locator sign shall be located in close proximity of each emergency exit and shall work in conjunction with the emergency exit sign. The location of the sign, directional arrow(s), or wording shall guide passengers and trainset crewmembers to the emergency exit route.

(c) *Rescue access signage/markings systems.* (1) Rescue access signage and marking systems shall enable emergency responders to make positive identification of rescue access points.

(2) Rescue access information for emergency responders placed on the exterior of the carbody shall, at a minimum, consist of the following:

(i) Each door intended for use by emergency responders for rescue access shall be identified with emergency access signs, symbols, or other conspicuous marking consisting of retroreflective material that complies

with paragraphs (d) and (e) of this section.

(ii) Rescue access door control locator signs/markings and instructions;

(A) Each door intended for use by emergency responders for rescue access shall have operating instructions for opening the door from outside the car placed on or immediately adjacent to the door on the carbody. If a power door does not function with an integral release mechanism, the instructions shall indicate the location of the exterior manual door control.

(B) Each power door intended for use by emergency responders for rescue access which has a non-integral release mechanism located away from the door, shall have a door control sign/markings placed at the location of this control that provides instructions for emergency operation, either as part of the access sign/markings or as another sign/markings.

(C) Each car equipped with manual doors shall have operating instructions for opening the door from the exterior, either as part of the access sign/markings or as another sign/markings.

(iii) Rescue access window locator signs/markings and instructions;

(A) Each rescue access window shall be identified with a unique retroreflective and easily recognizable sign, symbol, or other conspicuous marking that complies with paragraphs (d) and (e) of this section.

(B) Signs, symbols, or marking shall be placed at the bottom of each such window, on each window, or adjacent

to each window, utilizing arrows, where necessary, to clearly designate rescue assess window location. Legible and understandable window-access instructions, including any pictogram/ instructions for removing the window, shall be posted at or near each rescue access window.

(iv) Roof access locator signs/ markings and instructions.

(A) The location of each emergency access point provided on the roof of a passenger car shall be clearly marked with retroreflective material of contrasting color that complies with paragraphs (d) and (e) of this section.

(B) Legible and understandable instructions shall be posted at or near each such location.

(C) If emergency roof access is provided by means of a structural weak point:

(1) The retroreflective material shall clearly mark the line along which the roof skin shall be cut; and

(2) A sign plate with a retroreflective border shall also state:

CAUTION—DO NOT USE FLAME CUTTING DEVICES.

CAUTION—WARN PASSENGERS BEFORE CUTTING.

CUT ALONG DASHED LINE TO GAIN ACCESS.

ROOF CONSTRUCTION—[STATE RELEVANT DETAILS].

(d) *Color contrast.* Exterior signs/ markings shall provide luminance contrast ratio of not less than 0.5, as measured by a color-corrected photometer.

(e) *Materials*—(1) *Retroreflective material.* Exterior emergency rescue access locator signs/markings shall be constructed of retroreflective material that conforms to the specifications for Type I material sheeting, as specified in ASTM D 4956–07 <sup>epsiv:1</sup> (incorporated by reference, see § 299.17), “as tested in accordance with ASTM E 810–03 (incorporated by reference, see § 299.17).

(2) *HPPL materials.* All HPPL materials used in finished component configurations shall comply with the minimum luminance criterion of 7.5 mcd/m<sup>2</sup> after 90 minutes when tested according to the provisions of ASTM E 2073–07 (incorporated by reference, see § 299.17), with the following three modifications:

(i) *Activation.* The HPPL material shall be activated with a fluorescent lamp of 40W or less and a color temperature of 4000–4500K that provides no more than 10.7 lux (1 fc) of illumination as measured on the material surface. The activation period shall be for no more than 60 minutes.

(ii) *Luminance.* The photopic luminance of all specimens of the HPPL material shall be measured with a luminance meter as defined in section 5.2 of ASTM E 2073–07, a minimum of 90 minutes after activation has ceased.

(iii) *Luminance in mcd/m<sup>2</sup>.* The test report shall include a luminance measurement 90 minutes after activation has ceased.

(f) *Recordkeeping.* (1) The railroad shall retain a copy of the car manufacturer/supplier provided independent laboratory certified test report results showing that the illuminance or luminance measurements, as appropriate, on the active area of the signage/markings component. Such records shall be kept until all cars with those components are retired, transferred, leased, or conveyed to another railroad for use in revenue service. A copy of such records shall be transferred to the accepting railroad along with any such cars.

(2) The railroad shall retain a copy of the railroad-approved illuminance test plan(s) and test results until the next periodic test, or other test specified in accordance with the railroad’s inspection, testing, and maintenance program is conducted on a representative car/area, or until all cars of that type are retired, or are transferred, leased, or conveyed to another railroad. A copy of such records shall be transferred to the accepting railroad along with such car(s).

(3) The railroad shall retain a copy of the certified independent laboratory test report results that certify that the retroreflective material complies with Type I materials per ASTM D–4956–07 <sup>epsiv:1</sup> until all cars containing the retroreflective material are retired, or are transferred, leased, or conveyed to another railroad. A copy of such records shall be provided to the accepting railroad along with any car(s) that are transferred, leased, or conveyed.

#### § 299.425 Low-location emergency exit path marking.

(a) *General.* Low-location emergency exit path marking (LLEEPM) shall be provided in each unit of a trainset. The LLEEPM system shall be designed to identify the location of primary door exits and the exit path to be used to reach such doors by passengers and trainset crewmembers under conditions of darkness when normal and emergency sources of illumination are obscured by smoke or are inoperative.

(b) *Visual identity and recognition.* The LLEEPM system shall be conspicuous (*i.e.*, clearly recognizable/ distinguishable), or become conspicuous immediately and

automatically from a low-location upon loss of power for normal lighting, and under the minimum general emergency light illumination levels as specified in § 299.423.

(c) *Signage and markings.* At a minimum, the LLEEPM system shall have the following three components:

(1) *Primary door exit signs.* (i) Each primary door exit shall be clearly marked with an exit sign;

(ii) The exit sign shall be visible from a low-location from the exit along the exit path; and

(iii) Each exit sign shall be located on or immediately adjacent to each door and placed between 152.4 and 457.2 mm (6 and 18 inches) above the floor.

(2) *Primary door exit marking/delineators.* (i) The location of the exit path shall be marked using electrically powered (active) marking/delineators or light fixtures, HPPL (passive) marking/delineators or a combination of these two systems.

(ii) The requirements in this section apply for both electrical and HPPL components, whether installed on the walls, floors, or seat assemblies.

(iii) Each primary door shall be marked on or around the door’s operating handle.

(3) *Exit path marking/delineators.* (i) The marking/delineator components shall be positioned so as to identify an exit path to all primary exits that is clearly visible and easily recognizable from any seat or compartment in the trainset, when normal lighting and emergency lighting are unavailable in conditions of darkness and/or smoke.

(ii) Markings/delineators shall be located on the floor or no higher than 457.2 mm (18 inches) on the seat assembly, or walls/partitions of aisles, and/or passageways.

(iii) Changes in the direction of the exit path shall be indicated by the LLEEPM and be placed within 102 mm (4 inches) of the corner of the exit path.

(d) *Material*—(1) *HPPL passive systems.* HPPL strip marking/delineator material used for LLEEPM components shall be capable of providing a minimum luminance level of 7.5 mcd/m<sup>2</sup>, measured 90 minutes after normal power has ceased.

(2) *Electroluminescent marking/delineator strips.* The luminance value of the electroluminescent (EL) marking/delineator strip shall be at least 1,000 mcd/m<sup>2</sup>, as measured on the strip surface.

(e) *Conspicuity of markings.* LLEEPM signs shall comply with the text, color and respective illuminance or luminance requirements specified in § 299.423 and in this section.

(f) *Emergency performance duration.* The LLEPM system shall operate independently of the car's normal and emergency lighting systems for 90 minutes after loss of all power for normal lighting.

(g) *Recordkeeping.* (1) The railroad shall retain a copy of the car manufacturer/supplier provided certified independent laboratory test report results showing that the illuminance or luminance measurements, as appropriate, on the active area of the signage/markings/delineator component comply with the criteria specified in § 299.423 and in this section.

(2) The railroad shall retain a copy of the railroad-approved illuminance test plan(s) and test results until the next periodic test, or other test specified in accordance with the railroad's inspection, testing, and maintenance program and ensure that tests are conducted on a representative car, or until all cars of that type are retired, transferred, leased, or conveyed to another railroad. A copy of such records shall be provided to the accepting railroads along with any car(s) that are transferred, leased, or conveyed.

(3) Illegible, broken, damaged, missing, or non-functioning components of the LLEPM system, including the

normal and emergency power systems, shall be reported and repaired in accordance with the railroad's inspection, testing, and maintenance program as specified in § 299.445.

**§ 299.427 Emergency egress windows.**

(a) *Number and location.* Each unit in a trainset shall have a minimum of four emergency window exits. At least one emergency window exit shall be located in each side of each end (half) of the car, in a staggered configuration where practicable. (See Figure 3 to this paragraph.)

Figure 8 to paragraph (a) - Example of Location and Staggering of Emergency Window Exits and Access—Top and Side View Depictions

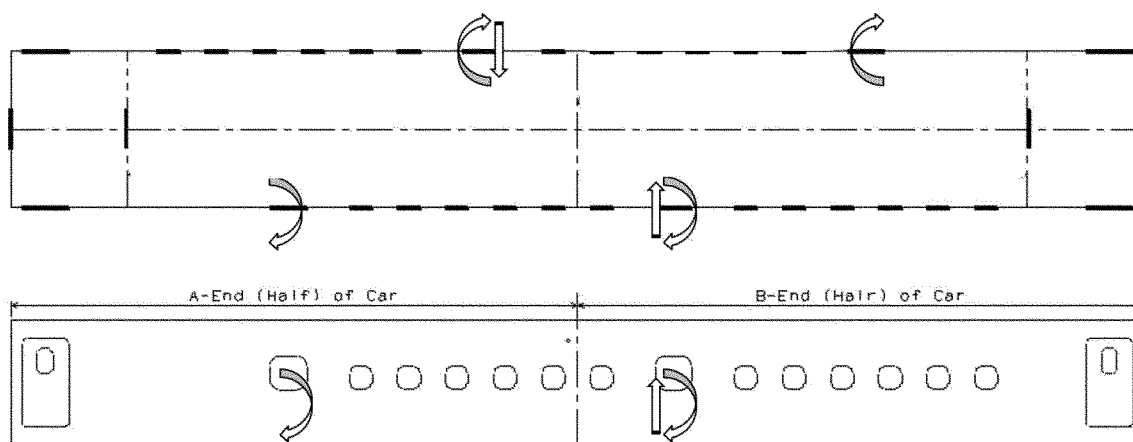

(b) *Ease of operability.* Each emergency egress window exit shall be designed to permit rapid and easy removal from the inside of the car during an emergency situation using a hammer designed to break the glazing that shall be located adjacent to each emergency window. The railroad shall inspect for the presence of the emergency hammers each day prior to the trainset being placed into service in accordance with § 299.711(b).

(c) *Dimensions.* Except as provided in paragraph (c)(1) of this section, each emergency egress window in a passenger car shall have an unobstructed opening with minimum dimensions of 660 mm (26 inches) horizontally by 610 mm (24 inches) vertically. A seatback is not an obstruction if it can be moved away from the window opening without using a tool or other implement.

(d) *Marking and instructions.* (1) Each emergency window exit shall be conspicuously and legibly marked with

luminescent material on the inside of each car to facilitate passenger egress as specified in § 299.423.

(2) Legible and understandable operating instructions, including instructions for removing the window shall be made of luminescent material, shall be posted at or near each such window exit as specified in § 299.423.

(e) *Obstructions.* If window removal may be hindered by the presence of a seatback, headrest, luggage rack, or other fixture, the instructions shall state the method for allowing rapid and easy removal of the window, taking into account the fixture(s), and this portion of the instructions may be in written or pictorial format.

(f) *Additional emergency window exits.* Any emergency window exit in addition to the minimum number required by paragraph (a) of this section that has been designated for use by the railroad need not comply with the minimum dimension requirements in paragraph (c) of this section, but must

otherwise comply with all requirements in this subpart applicable to emergency egress window.

**§ 299.429 Rescue access windows.**

(a) *General.* Each emergency egress window required by § 299.427 shall also serve as a means of rescue access.

(b) *Ease of operability.* Each rescue access window must be capable of being removed without unreasonable delay by an emergency responder using tools or implements that are commonly available to the responder in a passenger trainset emergency.

(c) *Marking and instructions.* (1) Each rescue access window shall be marked with retroreflective material on the exterior of each car as specified in § 299.423. A unique and easily recognizable symbol, sign, or other conspicuous marking shall also be used to identify each such window.

(2) Legible and understandable window-access instructions, including instructions for removing the window, shall be posted at or near each rescue

access window as specified in § 299.423.

**§ 299.431 Driver's controls and cab layout.**

(a) *Driver controls and cab layout.*

Driver controls and cab layout shall replicate that used in the N700, unless otherwise approved by FRA.

(b) *Cab seating.* Each seat provided for an employee regularly assigned to occupy a cab and any floor-mounted seat in the cab shall be securely attached in accordance with § 299.405.

(c) *Cab interior surface.* Sharp edges and corners shall be eliminated from the interior of the cab, and interior surfaces of the cab likely to be impacted by an employee during a collision or derailment shall be padded with shock-absorbent material.

(d) *Cab securement.* Trainset interior cab doors shall be equipped with the following:

(1) A secure and operable device to lock the door from the outside that does not impede egress from the cab; and

(2) A securement device on each cab door that is capable of securing the door from inside of the cab.

(e) *Cab glazing serviceability.* End-facing cab windows of the lead trainset cab shall be free of cracks, breaks, or other conditions that obscure the view of the right-of-way for the crew from their normal position in the cab.

(f) *Floors of cabs, passageways, and compartments.* Floors of cabs, passageways, and compartments shall be kept free from oil, water, waste or any obstruction that creates a slipping, tripping or fire hazard. Floors shall be properly treated to provide secure footing.

(g) *Cab environmental control.* Each lead cab in a trainset shall be heated and air conditioned. The HVAC system shall be inspected and maintained to ensure that it operates properly and meets the railroad's performance standard which shall be defined in the inspection, testing, and maintenance program.

(h) *Trainset cab noise.* Performance standards for the railroad's trainsets:

(1) The average noise levels in the trainset cab shall be less than or equal to 85 dB(A) when the trainset is operating at maximum approved trainset speed as approved under § 299.609(g). Compliance with this paragraph (h)(1) shall be demonstrated during the trainset qualification testing as required by § 299.607.

(2) The railroad shall not make any alterations during maintenance or modifications to the cab, that cause the average sound level to exceed the requirements in paragraph (1) of this section.

(3) The railroad or manufacturer shall follow the test protocols set forth in

appendix C to this part to determine compliance with paragraph (l)(1) of this section, and, to the extent reasonably necessary to evaluate the effect of alterations during maintenance, to determine compliance with paragraph (l)(2) of this section.

(i) *Maintenance of trainset cabs.* (1) If the railroad receives an excessive noise report, and if the condition giving rise to the noise is not required to be immediately corrected under this part, the railroad shall maintain a record of the report, and repair or replace the item identified as substantially contributing to the noise:

(i) On or before the next periodic inspection required by the railroad's inspection, testing, and maintenance program under subpart G; or

(ii) If the railroad determines that the repair or replacement of the item requires significant shop or material resources that are not readily available, at the time of the next major equipment repair commonly used for the particular type of maintenance needed.

(2) The railroad has an obligation to respond to an excessive noise report that a trainset-cab-occupant files. The railroad meets its obligation to respond to an excessive noise report, as set forth in paragraph (m)(1) of this section, if the railroad makes a good faith effort to identify the cause of the reported noise, and where the railroad is successful in determining the cause, if the railroad repairs or replaces the items that cause the noise.

(3)(i) The railroad shall maintain a written or electronic record of any excessive noise report, inspection, test, maintenance, replacement, or repair completed pursuant to paragraph (m) of this section, and the date on which that inspection, test, maintenance, replacement, or repair occurred. If the railroad elects to maintain an electronic record, the railroad must satisfy the conditions listed in § 299.11.

(ii) The railroad shall retain these records for a period of one year.

(iii) The railroad shall establish an internal, auditable, monitorable system that contains these records.

(m) *Trainset sanitation facilities for employees.* Sanitation facilities shall be provided for crewmembers either:

(1) On the trainset, that meet otherwise applicable sanitation standards, which are accessible at frequent intervals during the course of their work shift; or

(2) Ready access to railroad-provided sanitation facilities outside of the trainset.

(j) *Speed indicators.* (1) Each trainset controlling cab shall be equipped with a speed indicator which is—

(i) Accurate within  $\pm 2$  km/h (1.24 miles per hour) for speed lower than 30 km/h (18.6 miles per hour), then increasing linearly up to  $\pm 12$  km/h (7.5 miles per hour) at 500 km/h (311 miles per hour); and

(ii) Clearly readable from the driver's normal position under all light conditions.

(2) The speed indicator shall be based on a system of independent on-board speed measurement sources guaranteeing the accuracy level specified in paragraph (a)(1) of this section under all operational conditions. The system shall be automatically monitored for inconsistencies and the engineer shall be automatically notified of any inconsistency potentially compromising this accuracy level.

(3) The speed indicator shall be calibrated periodically as defined in the railroad's inspection, testing, and maintenance program.

(k) *Cab lights.* (1) Each trainset cab shall have cab lights which will provide sufficient illumination for the control instruments, meters, and gauges to enable the driver to make accurate readings from his or her normal positions in the cab. These lights shall be located, constructed, and maintained so that light shines only on those parts requiring illumination and does not interfere with the driver's vision of the track and signals. Each trainset cab shall also have a conveniently located light that can be readily turned on and off by the driver operating the trainset and that provides sufficient illumination for them to read trainset orders and timetables.

(2) Cab passageways and compartments shall be illuminated.

**§ 299.433 Exterior lights.**

(a) *Headlights.* Each leading end of a trainset shall be equipped with two or more headlights.

(1) Each headlight shall produce 80,000 candela.

(2) Headlights shall be arranged to illuminate signs in the right-of-way.

(3) Headlights shall be recognized 600 m (1,968 feet) ahead of the cab car by a driver in another trainset or a maintenance person standing in the right-of-way under clear weather conditions.

(b) *Taillights (marking devices).* (1) The trailing end of the trainset shall be equipped with two red taillights;

(2) Each taillight shall be located at least 1.2 m (3.9 feet) above rail;

(3) Each taillight shall be recognizable 200 m (656 feet) ahead of the cab car by a driver in another trainset or a maintenance person standing in the

right-of-way under clear weather conditions;

(4) Taillights of the trailing end of the trainset shall be on when the trainset is in operation;

(5) Taillights shall not be on in the direction of trainset travel, except if the driver shall re-position the trainset in a station. Such re-positioning operations shall be done in accordance with the railroad's operating rules; and

(6) In an emergency situation, the headlight on the rear of the trainset may serve as the taillights in accordance with the railroad's operating rules.

#### § 299.435 Electrical system design.

(a) *Overhead collector systems.* (1) Pantographs shall be so arranged that they can be operated from the driver's normal position in the cab. Pantographs that automatically rise when released shall have an automatic locking device to secure them in the down position.

(2) Each overhead collector system, including the pantograph, shall be equipped with a means to electrically ground any uninsulated parts to prevent the risk of electrical shock when working on the system.

(3) Means shall be provided to permit the driver to determine that the pantograph is in its lowest position, and for securing the pantograph if necessary, without the need to mount the roof of the trainset.

(4) Each trainset equipped with a pantograph operating on an overhead collection system shall also be equipped with a means to safely lower the pantograph in the event of an emergency. If an emergency pole is used for this purpose, that part of the pole which can be safely handled shall be marked to so indicate. This pole shall be protected from moisture and damage when not in use. Means of securement and electrical isolation of a damaged pantograph, when it cannot be performed automatically, shall be addressed in the railroad's operating rules.

(b) *Circuit protection.* (1) Each auxiliary circuit shall be provided with a circuit breaker or equivalent current-limiting devices located as near as practicable to the point of connection to the source of power for that circuit. Such protection may be omitted from circuits controlling safety-critical devices.

(2) The 25-kV main power line shall be protected with a lightning arrestor, automatic circuit breaker, and overload relay. The lightning arrestor shall be run by the most direct path possible to ground with a connection to ground of not less than No. 6 AWG. These overload protection devices shall be

housed in an enclosure designed specifically for that purpose with the arc chute vented directly to outside air.

(3) Auxiliary power supply (440 VAC), providing power distribution, shall be provided with both overload and ground fault protection.

(c) *Main battery system.* (1) The main batteries shall be isolated from the cab and passenger seating areas by a non-combustible barrier.

(2) If batteries are of the type to potentially vent explosive gases, the batteries shall be adequately ventilated to prevent accumulation of explosive concentrations of these gases.

(3) Battery chargers shall be designed to protect against overcharging.

(4) Battery circuits shall include an emergency battery cut-off switch to completely disconnect the energy stored in the batteries from the load.

(d) *Capacitors for high-energy storage.*

(1) Capacitors, if provided, shall be isolated from the cab and passenger seating areas by a non-combustible barrier.

(2) Capacitors shall be designed to protect against overcharging and overheating.

(e) *Electromagnetic interference (EMI) and electromagnetic compatibility (EMC).* (1) The railroad shall ensure electromagnetic compatibility of the safety-critical equipment systems with their environment. Electromagnetic compatibility can be achieved through equipment design or changes to the operating environment.

(2) The electronic equipment shall not produce electrical noise that interferes with trainline control and communications or with wayside signaling systems.

(3) To contain electromagnetic interference emissions, suppression of transients shall be at the source wherever possible.

(4) Electrical and electronic systems of equipment shall be capable of operation in the presence of external electromagnetic noise sources.

(5) All electronic equipment shall be self-protected from damage or improper operation, or both, due to high voltage transients and long-term over-voltage or under-voltage conditions. This includes protection from both power frequency and harmonic effects as well as protection from radio frequency signals into the microwave frequency range.

(f) *Insulation or grounding of metal parts.* All unguarded noncurrent-carrying metal parts subject to becoming charged shall be grounded or thoroughly insulated.

(g) *High voltage markings: Doors, cover plates, or barriers.* External surfaces of all doors, cover plates, or

barriers providing direct access to high voltage equipment shall be conspicuously and legibly marked "DANGER-HIGH VOLTAGE" or with the word "DANGER" and the normal voltage carried by the parts so protected. Labels shall be retro-reflective.

(h) *Hand-operated switches.* All hand-operated switches carrying currents with a potential of more than 150 volts that may be operated while under load shall be covered and shall be operative from the outside of the cover. Means shall be provided to show whether the switches are open or closed. Switches that should not be operated while under load shall be conspicuously and legibly marked with the words "must not be operated under load" and the voltage carried.

(i) *Conductors; jumpers; cable connections.* (1) Conductor sizes shall be selected on the basis of current-carrying capacity, mechanical strength, temperature, flexibility requirements, and maximum allowable voltage drop. Current-carrying capacity shall be derated for grouping and for operating temperature.

(2) Jumpers and cable connections between trainset units shall be located and guarded to provide sufficient vertical clearance. They may not hang with one end free.

(3) Cable and jumper connections between trainset units may not have any of the following conditions:

- (i) Broken or badly chafed insulation;
- (ii) Broken plugs, receptacles, terminals, or trainline pins; and
- (iii) Broken or protruding strands of wire.

(j) *Traction motors.* All traction motors shall be in proper working order, or safely cut-out.

#### § 299.437 Automated monitoring.

(a) Each trainset shall be equipped to monitor the performance of the following systems or components:

(1) Reception of cab and trainset control signals;

(2) Electric brake status;

(3) Friction brake status;

(4) Fire detection systems, if so equipped;

(5) Auxiliary power status;

(6) Wheelslide;

(7) On-board bearing-temperature sensors;

(8) Door open/closed status; and,

(9) Bogie vibration detection.

(b) When any of the monitored parameters are out of predetermined limits, an alert shall be sent immediately to the driver. The railroad's operating rules shall control trainset movement when the monitored parameters are out of predetermined limits.

(c) The railroad shall develop appropriate operating rules to address driver and equipment performance in the event that the automatic monitoring system becomes defective.

(d) The monitoring system shall be designed with an automatic self-test feature that notifies the driver that the monitoring capability is functioning correctly and alerts the driver when a system failure occurs.

**§ 299.439 Event recorders.**

(a) *Duty to equip and record.* Each trainset shall be equipped with an operative event recorder that monitors and records as a minimum all safety data required by paragraph (b) of this section. The event recorder shall record the most recent 48 hours of operational data of the trainset on which it is installed.

(b) *Equipment requirements.* Event recorders shall monitor and record data elements or information needed to support the data elements required by this paragraph. The data shall be recorded with at least the accuracy required of the indicators displaying any of the required data elements to the driver.

(c) *Data elements.* The event recorder shall be equipped with a certified crashworthy event recorder memory module that meets the requirements of appendix B to this part. The certified event recorder memory module shall be mounted for its maximum protection. The event recorder shall record, and the certified crashworthy event recorder memory module shall retain, the following data elements or information needed to support the data elements:

- (1) Trainset speed;
- (2) Selected direction of motion;
- (3) Date and time;
- (4) Distance traveled;
- (5) Throttle position;

(6) Applications and operations of the trainset brake system, including urgent and emergency applications. The system shall record, or provide a means of determining, that a brake application or release resulted from manipulation of brake controls at the position normally occupied by the driver. In the case of a brake application or release that is responsive to a command originating from or executed by an on-board computer (e.g., electronic braking system controller, controlling cab electronic control system, or trainset control computer), the system shall record, or provide a means of determining, the involvement of any such computer;

(7) Applications and operations of the regenerative brake;

- (8) Cab signal aspect(s);

- (9) Urgent brake application(s);
- (10) Passenger brake alarm request;
- (11) Wheel slip/slide alarm activation (with a property-specific minimum duration);
- (12) Trainset number;
- (13) Trainset tractive effort (positive and negative);
- (14) Trainset brake cylinder pressures;
- (15) Cruise control on/off, if so equipped and used;
- (16) Bogie vibration detection;
- (17) Door status opened/closed; and
- (18) Safety-critical trainset control

data routed to the controlling driver's display with which the driver is required to comply, specifically including text messages conveying mandatory directives and maximum authorized speed. The specific information format, content, and proposed duration for retention of such data shall be specified in the PTC Safety Plan submitted for the trainset control system under subpart B, subject to FRA approval. If it can be calibrated against other data required by this part, such trainset control data may, at the election of the railroad, be retained in a separate certified crashworthy memory module.

(d) *Response to defective equipment.* A trainset on which the event recorder has been taken out of service may remain in-service only until the next pre-service inspection. A trainset with an inoperative event recorder is not deemed to be in improper condition, unsafe to operate, or a non-complying trainset under § 299.447.

(e) *Annual tests.* (1) The railroad's inspection, testing, and maintenance program under subpart H of this part shall require annual testing of the event recorder. All testing under this section shall be performed at intervals that do not exceed 368 calendar days.

(2) A microprocessor-based event recorder with a self-monitoring feature equipped to verify that all data elements required by this part are recorded, requires further maintenance and testing only if either of the following conditions exist:

- (i) The self-monitoring feature displays an indication of a failure. If a failure is displayed, further maintenance and testing must be performed until a subsequent test is successful. When a successful test is accomplished, a record, in any medium, shall be made of that fact and of any maintenance work necessary to achieve the successful result. This record shall be available at the location where the trainset is maintained until a record of a subsequent successful test is filed; or,
- (ii) A download of the event recorder, taken within the preceding 30 days and reviewed for the previous 48 hours of

trainset operation, reveals a failure to record a regularly recurring data element or reveals that any required data element is not representative of the actual operations of the trainset during this time period. If the review is not successful, further maintenance and testing shall be performed until a subsequent test is successful. When a successful test is accomplished, a record, in any medium, shall be made of that fact and of any maintenance work necessary to achieve the successful result. This record shall be kept at the location where the trainset is maintained until a record of a subsequent successful test is filed. The download shall be taken from information stored in the certified crashworthy crash hardened event recorder memory module.

(f) *Preserving accident data.* If any trainset equipped with an event recorder, or any other trainset mounted recording device or devices designed to record information concerning the functioning of a trainset, is involved in an accident/incident that is required to be reported to FRA under part 225 of this chapter, the railroad shall, to the extent possible, and to the extent consistent with the safety of life and property, preserve the data recorded by each such device for analysis by FRA in accordance with § 299.11. This preservation requirement permits the railroad to extract and analyze such data, provided the original downloaded data file, or an unanalyzed exact copy of it, shall be retained in secure custody and shall not be utilized for analysis or any other purpose except by direction of FRA or the National Transportation Safety Board. This preservation requirement shall expire one (1) year after the date of the accident/incident unless FRA or the Board notifies the railroad in writing that the data are desired for analysis.

(g) *Relationship to other laws.* Nothing in this section is intended to alter the legal authority of law enforcement officials investigating potential violation(s) of Federal or State criminal law(s), and nothing in this chapter is intended to alter in any way the priority of National Transportation Safety Board investigations under 49 U.S.C. 1131 and 1134, nor the authority of the Secretary of Transportation to investigate railroad accidents under 49 U.S.C. 5121, 5122, 20107, 20111, 20112, 20505, 20702, 20703, and 20902.

(h) *Disabling event recorders.* Except as provided in paragraph (d) of this section, any individual who willfully disables an event recorder, or who tampers with or alters the data recorded by such a device is subject to civil

penalty as provided in part 218 of this chapter, and to disqualification from performing safety-sensitive functions on a railroad under subpart D of part 209 of this chapter.

**§ 299.441 Trainset electronic hardware and software safety.**

(a) *Purpose and scope.* The requirements of this section apply to all safety-critical electronic control systems, subsystems, and components on the trainsets, except for on-board signaling and trainset control system components that must meet the software safety requirements defined in subpart B of this part.

(b) *Applicability.* (1) The trainsets shall utilize the service-proven safety-critical electronic control systems, subsystems, and components as used on the N700 to control and monitor safety-critical components.

(2) Any modifications to the existing service-proven safety-critical electronic control systems, subsystems, and components shall be subject to the requirements defined in paragraph (c) of this section.

(i) The railroad shall assure that the suppliers of new or modified safety-critical systems, subsystems, and components utilize an industry recognized hardware and software development process which is evaluated and certified by an independent third-party assessor authorized by the industry standard utilized.

(ii) The railroad shall require that all suppliers submit the certifications and audit results as applicable. All such certifications shall be made available to FRA upon request.

(3) Any major upgrades or introduction of new safety-critical technology shall be subject to § 299.613(d).

(c) *Electronic hardware and software safety program.* The railroad shall develop and maintain a written electronic hardware and software safety program to guide the design, development, testing, integration, and verification of all new or modified safety-critical trainset hardware and software.

(1) *Hardware and software safety program description.* The hardware and software safety program shall include a description of how the following will be implemented to ensure safety and reliability:

- (i) The hardware and software design process;
- (ii) The hardware and software design documentation;
- (iii) The hardware and software hazard analysis;
- (iv) Hardware and software safety reviews;

(v) Hardware and software hazard monitoring and tracking;

(vi) Hardware and software integration safety testing;

(vii) Demonstration of overall hardware and software system safety as part of the pre-revenue service testing of the equipment; and

(viii) Safety-critical changes and failures.

(2) *Safety analysis.* The hardware and software safety program shall be based on a formal safety methodology that includes a FMECA; verification and validation testing for all hardware and software components and their interfaces; and comprehensive hardware and software integration testing to ensure that the hardware and software system functions as intended.

(3) *Compliance.* The railroad shall comply with the elements of its hardware and software safety program that affect the safety of the passenger trainset.

(4) *Safety-critical changes and failures.* Whenever a planned safety-critical design change is made to the safety-critical electronic control systems, subsystems and components (the products) that are in use by the railroad and subject to this subpart, the railroad shall—

(i) Notify FRA in accordance with § 299.9 of the design changes made by the product supplier;

(ii) Ensure that the safety analysis required under paragraph (c)(2) of this section is updated as required;

(iii) Conduct all safety-critical changes in a manner that allows the change to be audited;

(iv) The railroad shall document all arrangements with suppliers for notification of all electronic safety-critical changes as well as safety-critical failures in the supplier's system, subsystem, or components, and the reasons for that change or failure from the suppliers, whether or not the railroad has experienced a failure of that safety-critical system, sub-system, or component;

(v) Specify the railroad's procedures for action upon receipt of notification of a safety-critical change or failure of an electronic system, sub-system, or component, and until the upgrade or revision has been installed;

(vi) Identify all configuration/revision control measures designed to ensure that safety-functional requirements and safety-critical hazard mitigation processes are not compromised as a result of any such change, and that any such change can be audited; and,

(vii) The railroad shall require suppliers to provide notification of all electronic safety-critical changes as well

as safety-critical failures in the supplier's system, subsystem, or components;

(viii) The reasons shall be identified for that change or failure from the suppliers, whether or not the railroad has experienced a failure of that safety-critical system, sub-system, or component; and,

(ix) The railroad shall document all arrangements with suppliers for notification of any and all electronic safety-critical changes as well as safety-critical failures in the supplier's system, subsystem, or components.

(d) *Specific requirements.* Hardware and software that controls or monitors a trainset's primary braking system shall either—

(1) Fail safely by initiating an emergency or urgent brake application in the event of a hardware or software failure that could impair the ability of the driver to apply or release the brakes; or

(2) Provide the driver access to direct manual control of the primary braking system (emergency or urgent braking).

(e) *Inspection, testing, and maintenance records.* The inspection, testing, and maintenance conducted by the railroad in accordance with § 299.445 shall be recorded in hardcopy or stored electronically. Electronic recordkeeping or automated tracking systems, subject to the provisions contained in § 299.11, may be utilized to store and maintain any testing or training record required by this subpart. Results of product testing conducted by a vendor in support of a safety analysis shall be provided to and recorded by the railroad.

(1) The testing records shall contain all of the following:

- (i) The name of the railroad;
- (ii) The location and date that the test was conducted;
- (iii) The equipment tested;
- (iv) The results of tests;
- (v) The repairs or replacement of equipment;
- (vi) Any preventative adjustments made; and
- (vii) The condition in which the equipment is left.

(2) Each record shall be—

- (i) Signed by the employee conducting the test, or electronically coded, or identified by the automated test equipment number;
- (ii) Filed in the office of a supervisory official having jurisdiction, unless otherwise noted; and
- (iii) Available for inspection and copying by FRA.

(3) The results of the testing conducted in accordance with this section shall be retained as follows:



(i) The results of tests that pertain to installation or modification of a product shall be retained for the life-cycle of the product tested and may be kept in any office designated by the railroad;

(ii) The results of periodic tests required for the maintenance or repair of the product tested shall be retained until the next record is filed and in no case less than one year; and

(iii) The results of all other tests and training shall be retained until the next record is filed and in no case less than one year.

(f) *Review of safety analysis.* (1) Prior to the initial planned use of a new product as defined by paragraphs (b)(2) or (3) of this section, the railroad shall notify FRA in accordance with § 299.9 of the intent to place this product in service. The notification shall provide a description of the product, and identify the location where the complete safety analysis documentation and the testing are maintained.

(2) The railroad shall maintain and make available to FRA upon request all railroad or vendor documentation used to demonstrate that the product meets the safety requirements of the safety analysis for the life-cycle of the product.

(g) *Hazard tracking.* After a new product is placed in service in accordance with paragraphs (b)(2) or (3) of this section, the railroad shall maintain a database of all safety-relevant hazards encountered with the product. The database shall include all hazards identified in the safety analysis and those that had not been previously identified in the safety analysis. If the frequency of the safety-relevant hazards exceeds the threshold set forth in the safety analysis, then the railroad shall—

(1) Report the inconsistency to the Associate Administrator, within 15 days of discovery in accordance with § 299.9;

(2) Take immediate countermeasures to reduce the frequency of the safety-relevant hazard(s) below the threshold set forth in the safety analysis; and

(3) Provide a final report to the Associate Administrator, on the results of the analysis and countermeasures taken to mitigate the hazard to meet the threshold set forth in the safety analysis when the problem is resolved. For hazards not identified in the safety analysis the threshold shall be exceeded at one occurrence.

(4) Electronic or automated tracking systems used to meet the requirements contained in paragraph (g) of this section shall be in accordance with § 299.11.

(h) *Operations and maintenance manual.* The railroad shall maintain all supplier or vendor documents pertaining to the operation, installation,

maintenance, repair, modification, inspection, and testing of the safety-critical electronic control systems, subsystems and components.

(i) *Training and qualification program.* Under § 299.13(c)(3), the railroad shall establish and implement a training and qualification program for the safety-critical electronic control systems, subsystems, and components subject to subpart G of this part prior to the safety-critical electronic control systems, subsystems, and components being placed in use.

(j) *Operating personnel training.* The training program required by § 299.13(c)(3) for any driver or other person who participates in the operation of a trainset using the safety-critical electronic control systems, subsystems and components shall address all the following elements:

(1) Familiarization with the electronic control system equipment on-board the trainset and the functioning of that equipment as part of the system and in relation to other on-board systems under that person's control;

(2) Any actions required of the operating personnel to enable or enter data into the system and the role of that function in the safe operation of the trainset;

(3) Sequencing of interventions by the system, including notification, enforcement, and recovery from the enforcement as applicable;

(4) Railroad operating rules applicable to control systems, including provisions for movement and protection of any unequipped passenger equipment, or passenger equipment with failed or cut-out controls;

(5) Means to detect deviations from proper functioning of on-board electronic control system equipment and instructions explaining the proper response to be taken regarding control of the trainset and notification of designated railroad personnel; and

(6) Information needed to prevent unintentional interference with the proper functioning of on-board electronic control equipment.

#### § 299.443 Safety appliances.

(a) *Couplers.* (1) The leading and trailing ends of each trainset shall be equipped with an automatic rescue coupler that couples on impact.

(i) Uncoupling of the rescue coupler shall be done only at a trainset maintenance facility or other location where personnel can safely get under or between units.

(ii) The leading and the trailing ends of a trainset are not required to be equipped with sill steps or end or side handholds.

(2) The leading and trailing end couplers and uncoupling devices may be stored within a removable shrouded housing.

(3) Leading and trailing automatic couplers of trainsets shall be compatible with the railroad's rescue vehicles. A coupler adaptor can be used to meet this requirement.

(4) The railroad shall develop and implement rescue procedures that assure employee safety during rescue operations and shall be contained in the railroad's operating rules.

(5) Each unit within a trainset shall be semi-permanently coupled and shall only be uncoupled at a trainset maintenance facility or other locations identified by the railroad where the protections afforded in subpart B of part 218 of this chapter can be applied.

(6) The ends of units in a trainset that are semi-permanently coupled are not required to be equipped with automatic couplers, sill steps, end handholds or side handholds.

(b) *Crew access.* (1) Each trainset shall provide a minimum of two (2) locations per side, where crew members can board or disembark the trainset safely from ground level.

(2) Each location used for crew access shall be equipped with retractable stairs with handrails designed for safe access to the trainset from ground level.

#### § 299.445 Trainset inspection, testing, and maintenance requirements.

(a) *General.* (1) The railroad shall develop a written inspection program for the rolling stock, in accordance with and approved under the requirements of § 299.713. As further specified in this section, the program shall describe in detail the procedures, equipment, and other means necessary for the safe operation of the passenger equipment, including all inspections set forth in paragraph (e) of this section. This information shall include a detailed description of the methods of ensuring accurate records of required inspections.

(2) The initial inspection, testing, and maintenance program submitted under § 299.713 shall, as a minimum, address the specific safety inspections contained in paragraphs (e)(1) through (4) of this section. The railroad may submit the procedures detailing the bogie inspections or general overhaul requirements contained in paragraph (e)(3) and (4) of this section, respectively, at a later date than the initial inspection, testing, and maintenance program, but not less than 180 days prior to the scheduled date of the first bogie inspection or general overhaul.

(b) *Identification of safety-critical items.* In addition to safety critical items identified under § 299.711(b), on-board emergency equipment, emergency back-up systems, trainset exits and trainset safety-critical hardware and software systems in accordance with § 299.441 shall be deemed safety-critical.

(c) *Compliance.* The railroad shall adopt and comply with the approved inspection, testing, and maintenance program in accordance with § 299.703.

(d) *General condition.* The inspection, testing, and maintenance program shall ensure that all systems and components of the equipment are free of conditions that endanger the safety of the crew, passengers, or equipment. These conditions include, but are not limited to the following:

(1) A continuous accumulation of oil or grease;

(2) Improper functioning of a component;

(3) A crack, break, excessive wear, structural defect, or weakness of a component;

(4) A leak;

(5) Use of a component or system under conditions that exceed those for which the component or system is designed to operate; and

(6) Insecure attachment of a component.

(e) *Specific safety inspections.* The program under paragraph (a) of this section shall specify that all passenger trainsets shall receive thorough safety inspections by qualified individuals designated by the railroad at regular intervals. At a minimum, and in addition to the annual tests required for event recorder under § 299.439(f), the following shall be performed on each trainset:

(1) *Pre-service inspections.* (i) Each trainset in use shall be inspected at least once every two calendar days by qualified individuals at a location where there is a repair pit and access to the top of the trainset. The inspection shall verify the correct operation of on-board safety systems defined in the inspection, testing, and maintenance program. If any of the conditions defined as safety-critical in paragraph (b) of this section and § 299.711(b) are found during this inspection, the trainset shall not be put into service until that condition is rectified. The pre-service inspection shall include the following:

(A) Functional tests to determine the status of application and release of the service, emergency, and urgent air brakes using the monitoring system;

(B) Operational tests of the exterior doors; and

(C) A review of the log of on-board ATC equipment.

(ii) If the existence of any safety-critical conditions cannot be determined by use of an automated monitoring system, the railroad shall perform a visual inspection to determine if the condition exists.

(2) *Regular inspections.* The railroad shall perform a regular inspection on all trainsets in accordance with the test procedures and inspection criteria established in paragraph (a) of this section and at the intervals defined by paragraph (f) of this section. If any of the conditions defined as safety-critical in paragraph (b) of this section and § 299.711(b) are found during this inspection, the trainset shall not be put into service until that condition is rectified.

(3) *Bogie inspections.* The railroad shall perform a bogie inspection on all trainsets in accordance with the test procedures and inspection criteria established in paragraph (a) of this section and at the intervals defined by paragraph (f) of this section. If any of the conditions defined as safety-critical in paragraph (b) of this section and § 299.711(b) are found during this inspection, the trainset shall not be put into service until that condition is rectified.

(4) *General overhaul.* The railroad shall perform a general overhaul on all trainsets in accordance with the test procedures and inspection criteria established in paragraph (a) of this section and at the intervals defined by paragraph (f) of this section. If any of the conditions defined as safety-critical in paragraph (b) of this section and § 299.711(b) are found during this inspection, the trainset shall not be put into service until that condition is rectified.

(f) *Maintenance intervals.* The railroad's program established pursuant to paragraph (a) of this section shall include the railroad's scheduled maintenance intervals for all specific safety inspections in paragraph (e) of this section, as required by § 299.707.

(g) *Training and qualification program.* The railroad shall establish a training and qualification program as defined in § 299.13(c)(3) to qualify individuals to perform inspections, testing, and maintenance on the equipment. Only qualified individuals shall perform inspections, testing, and maintenance of the equipment.

(h) *Reporting and tracking of repairs to defective trainsets.* The railroad shall have in place prior to start of operations a reporting and tracking system for passenger trainsets with a defect not in conformance with this subpart. The reporting and tracking system shall record the following information:

(1) The identification number of the defective unit within a trainset, and trainset identification number;

(2) The date the defect was discovered;

(3) The nature of the defect;

(4) The determination made by a qualified individual whether the equipment is safe to run;

(5) The name of the qualified individual making such a determination;

(6) Any operating restrictions placed on the equipment; and

(7) Repairs made and the date that they were completed.

(i) *Retention of records.* At a minimum, the railroad shall keep the records described in paragraph (j) of each required inspection under this section in accordance with § 299.11. Each record shall be maintained for at least one year from the date of the inspection.

(j) *Availability of records.* The railroad shall make defect reporting and tracking records available to FRA upon request.

(k) *Brake system repair points.* The railroad shall designate brake system repair points in the inspection, testing, and maintenance program required by paragraph (a) of this section. No trainset shall depart a brake system repair point unless that trainset has a 100 percent operational brake system.

#### **§ 299.447 Movement of defective equipment.**

(a) A trainset with one or more conditions not in compliance with the list of safety critical defects identified in accordance with § 299.445(b) during a pre-service inspection required by § 299.445(e)(1) shall not be moved in revenue service and shall only be moved in accordance with paragraph (e) of this section.

(b) Except as provided in paragraph (c) of this section, and after departure in compliance with the pre-service inspection required by § 299.445(e)(1), a trainset with one or more conditions not in compliance with the list of safety critical defects identified in accordance with §§ 299.445(b) and 299.711(b) may be moved in revenue service only after the railroad has complied with all of the following:

(1) A qualified individual determines that it is safe to move the trainset, consistent with the railroad's operating rules;

(i) If appropriate, these determinations may be made based upon a description of the defective condition provided by a crewmember.

(ii) If the determinations required by this paragraph are made by an off-site qualified individual based on a

description of the defective condition by on-site personnel, then a qualified individual shall perform a physical inspection of the defective equipment, at the first location possible, in accordance with the railroad's inspection, testing, and maintenance program and operating rules, to verify the description of the defect provided by the on-site personnel.

(2) The qualified individual who made the determination in paragraph (b)(1) of this section, notifies the driver in charge of movement of the trainset, in accordance with the railroad's operating rules, of the maximum authorized speed, authorized destination, and any other operational restrictions that apply to the movement of the non-compliant trainset. This notification may be achieved through the tag required by paragraph (b)(3) of this section; and

(3) A tag bearing the words "non-complying trainset" and containing the following information, are securely attached to the control stand on each control cab of the trainset:

(i) The trainset number and unit or car number;

(ii) The name of the qualified individual making the determination in paragraph (b)(1) of this section;

(iii) The location and date of the inspection that led to the discovery of the non-compliant item;

(iv) A description of each defect;

(v) Movement restrictions, if any;

(vi) The authorized destination of the trainset; and,

(vii) The signature, if possible, as well as the job title and location of the person making the determinations required by this section.

(4) Automated tracking systems used to meet the tagging requirements contained in paragraph (b)(3) of this section may be reviewed and monitored by FRA at any time to ensure the integrity of the system. FRA's Associate Administrator may prohibit or revoke the railroad's ability to utilize an automated tracking system in lieu of tagging if FRA finds that the automated tracking system is not properly secure, is inaccessible to FRA or the railroad's employees, or fails to adequately track or monitor the movement of defective equipment. Such a determination will be made in writing and will state the basis for such action.

(c) A trainset that develops a non-complying condition in service may continue in revenue service, so long as the requirements of paragraph (b) of this section are otherwise fully met, until the next pre-service inspection.

(d) In the event of an in-service failure of the braking system, the trainset may

proceed in accordance with the railroad's operating rules relating to the percentage of operative brakes and at a speed no greater than the maximum authorized speed as determined by § 299.409(f)(4) so long as the requirements of paragraph (b) of this section are otherwise fully met, until the next pre-service inspection.

(e) A non-complying trainset may be moved without passengers within a trainset maintenance facility, at speeds not to exceed 16 km/h (10 mph), without meeting the requirements of paragraph (a) of this section where the movement is solely for the purpose of repair. The railroad shall ensure that the movement is made safely.

(f) Nothing in this section authorizes the movement of equipment subject to a Special Notice for Repair under part 216 of this chapter unless the movement is made in accordance with the restrictions contained in the Special Notice.

### Subpart E—Operating Rules

#### § 299.501 Purpose.

Through the requirements of this subpart, FRA learns the condition of the operating rules and practices in use by the railroad. The rules and practices covered by this subpart include the procedures for instruction and testing of all employees involved with the movement of rail vehicles, including drivers, on-board attendants, station platform attendants, general control center staff, and all maintenance staff, which are necessary to ensure that they possess the requisite skill and knowledge of the rules and operating practices to maintain the safety of the system.

#### § 299.503 Operating rules; filing and recordkeeping.

(a) Prior to commencing operations, the railroad shall develop a code of operating rules, timetables, and timetable special instructions. The initial code of operating rules, timetables, and timetable special instructions shall be based on practices and procedures proven on the Tokaido Shinkansen system.

(b) The railroad shall keep one copy of its current code of operating rules, timetables, timetable special instruction, at its system headquarters, and shall make them available to FRA for inspection and copying during normal business hours. If the railroad elects to maintain an electronic record, the railroad must satisfy the conditions listed in § 299.11.

#### § 299.505 Programs of operational tests and inspections; recordkeeping.

(a) *Requirement to conduct operational tests and inspections.* The railroad shall periodically conduct operational tests and inspections to determine the extent of employee knowledge, application, and compliance with its code of operating rules, timetables, and timetable special instructions in accordance with a written program retained at its system headquarters.

(b) *Railroad and railroad testing officer responsibilities.* (1) Each railroad officer who conducts operational tests and inspections (railroad testing officer) shall—

(i) Be qualified on the railroad's operating rules in accordance with § 299.507;

(ii) Be qualified on the operational testing and inspection program requirements and procedures relevant to the testing and inspections the officer will conduct;

(iii) Receive appropriate field training, as necessary to achieve proficiency, on each operational test or inspection that the officer is authorized to conduct; and

(iv) Conduct operational tests and inspections in accordance with the railroad's program of operational tests and inspections.

(2) The railroad shall maintain a record documenting qualification of each railroad testing officer. The record shall be retained by the railroad and shall be made available to representatives of the FRA for inspection and copying during normal business hours. If the railroad elects to maintain an electronic record, the railroad must satisfy the conditions listed in § 299.11.

(c) *Written program of operational tests and inspections.* Within 30 days of commencing operations, the railroad shall have a written program of operational tests and inspections in effect. The railroad shall maintain one copy of its current program for periodic performance of the operational tests and inspections required by paragraph (a) of this section, and shall maintain one copy of each subsequent amendment to the program as amendments are made. These records shall be retained at the system headquarters of the railroad for three calendar years after the end of the calendar year to which they relate. These records shall be made available to representatives of the FRA for inspection and copying during normal business hours. The program shall—

(1) Provide for operational testing and inspection under the various operating conditions on the railroad;

(2) Describe each type of operational test and inspection adopted, including the means and procedures used to carry it out;

(3) State the purpose of each type of operational test and inspection;

(4) State the frequency with which each type of operational test and inspection is conducted;

(5) The program shall address with particular emphasis those operating rules that cause or are likely to cause the most accidents or incidents, such as those accidents or incidents identified in the six-month reviews and the annual summaries as required under paragraphs (e) and (f) of this section;

(6) Identify the officer(s) by name and job title responsible for ensuring that the program of operational tests and inspections is properly implemented and is responsible for overseeing the entire program. The responsibilities of such officer(s) shall include, but not be limited to, ensuring that the railroad's testing officers are directing their efforts in an appropriate manner to reduce accidents/incidents and that all required reviews and summaries are completed, and

(7) Include a schedule for making the program fully operative within 210 days after it begins.

(d) *Records.* (1) The railroad shall keep a written or electronic record of the date, time, place, and result of each operational test and inspection that was performed in accordance with its program. Each record shall specify the officer administering the test and inspection and each employee tested. These records shall be retained at the system headquarters of the railroad for one calendar year after the end of the calendar year to which they relate. These records shall be made available to representatives of the FRA for inspection and copying during normal business hours.

(2) The railroad shall retain one copy of its current program for periodic performance of the operational tests and inspections required by paragraph (a) of this section and one copy of each subsequent amendment to such program. These records shall be retained for three calendar years after the end of the calendar year to which they relate at the system headquarters where the tests and inspections are conducted. These records shall be made available to representatives of the FRA for inspection and copying during normal business hours.

(e) *Reviews of tests and inspections and adjustments to the program of operational tests*—(1) *Reviews by the railroad.* Not less than once every 180 days the railroad's designated officer(s)

shall conduct periodic reviews and analyses as provided in this paragraph and shall retain, at its system headquarters, one copy of the reviews. Each such review shall be completed within 30 days of the close of the period. The designated officer(s) shall conduct a written review of—

(i) The operational testing and inspection data for the system to determine compliance by the railroad testing officers with its program of operational tests and inspections required by paragraph (c) of this section. At a minimum, this review shall include the name of each railroad testing officer, the number of tests and inspections conducted by each officer, and whether the officer conducted the minimum number of each type of test or inspection required by the railroad's program;

(ii) Accident/incident data, the results of prior operational tests and inspections, and other pertinent safety data for the system to identify the relevant operating rules related to those accidents/incidents that occurred during the period. Based upon the results of that review, the designated officer(s) shall make any necessary adjustments to the tests and inspections required of railroad officers for the subsequent period(s); and

(iii) Implementation of the program of operational tests and inspections from a system perspective, to ensure that it is being utilized as intended, that the other reviews provided for in this paragraph have been properly completed, that appropriate adjustments have been made to the distribution of tests and inspections required, and that the railroad testing officers are appropriately directing their efforts.

(2) *Records retention.* The records of reviews required in paragraphs (e)(1) of this section shall be retained for a period of one year after the end of the calendar year to which they relate and shall be made available to representatives of FRA for inspection and copying during normal business hours.

(f) *Annual summary on operational tests and inspections.* Before March 1 of each calendar year, the railroad shall retain, at its system headquarters, one copy of a written summary of the following with respect to its previous year's activities: The number, type, and result of each operational test and inspection that was conducted as required by paragraphs (a) and (b) of this section. These records shall be retained for three calendar years after the end of the calendar year to which they relate and shall be made available to representatives of FRA for inspection

and copying during normal business hours.

(g) *Electronic recordkeeping.* Nothing in this section precludes the railroad from maintaining the information required to be retained under this part in an electronic format provided that the railroad satisfy the conditions listed in § 299.11.

(h) *Disapproval of program.* Upon review of the program of operational tests and inspections required by this section, the Associate Administrator for Safety may, for cause stated, disapprove the program in whole or in part. Notification of such disapproval shall be made in writing and specify the basis for the disapproval decision. If the Associate Administrator for Safety disapproves the program—

(1) The railroad has 35 days from the date of the written notification of such disapproval to—

(i) Amend its program; or

(ii) Provide a written response in support of the program to the Associate Administrator for Safety. If the Associate Administrator for Safety still disapproves the program in whole or in part after receiving the railroad's written response, the railroad shall amend its program.

(2) A failure to adequately amend the program will be considered a failure to implement a program under this subpart.

**§ 299.507 Program of instruction on operating rules; recordkeeping.**

(a) To ensure that each railroad employee whose activities are governed by the railroad's operating rules understands those rules, the railroad shall periodically instruct each such employee on the meaning and application of its operating rules with a written program developed under § 299.13(c)(3) and retained at its system headquarters.

(b) Prior to commencing operations, the railroad shall file and retain one copy of its current program for the periodic instruction of its employees as required by paragraph (a) of this section and shall file and retain one copy of any amendment to that program as amendments are made. These records shall be retained at the railroad's system headquarters for one calendar year after the end of the calendar year to which they relate. These records shall be made available to representatives of the FRA for inspection and copying during normal business hours. This program shall—

(1) Describe the means and procedures used for instruction of the various classes of affected employees;

(2) State the frequency of instruction and the basis for determining that frequency;

(3) Include a schedule for completing the initial instruction of employees who are already employed when the program begins;

(4) Begin on the date of commencing operations; and

(5) Provide for initial instruction of each employee hired after the program begins.

(c) The railroad is authorized to retain by electronic recordkeeping its program for periodic instruction of its employees on operating rules, provided that the requirements stated in § 299.11 are satisfied.

### Subpart F—System Qualification Tests

#### § 299.601 Responsibility for verification demonstrations and tests.

The railroad shall comply with the pre-revenue qualification tests and verification requirements set forth in this subpart to demonstrate the overall safety of the system, prior to revenue operations.

#### § 299.603 Preparation of system-wide qualification test plan.

(a) Prior to execution of any tests as defined in this subpart, the railroad shall develop a system-wide qualification test plan, that identifies the tests that will be carried out, to demonstrate the operability of all system elements, including track and infrastructure, signal and train control, communications, rolling stock, software, and operating practices, and the system as a whole.

(b) The system-wide qualification test plan shall be submitted to FRA in accordance with § 299.9 for review at least 180 days prior to testing. FRA shall notify the railroad, in writing, within 45 days of receipt of the railroad's submission, and identify any deficiencies in the test plan. FRA will notify the railroad of any procedures to be submitted for review. The plan shall include the following:

(1) A list of all tests to be conducted;

(2) A summary statement of the test objectives;

(3) A planned schedule for conducting the tests which indicates the sequence of testing and interdependencies; and

(4) The approach taken for—

(i) Verifying results of installation tests performed by contractors and manufacturers;

(ii) Functional and performance qualification testing of individual safety-related equipment, facilities, and subsystems in accordance with § 299.605;

(iii) Pre-revenue service systems integration testing of the system per § 299.607, that includes vehicle/track system qualification testing per § 299.609;

(iv) Simulated revenue operations of the system per § 299.611;

(v) Compliance with operating rules as per subpart E of this part;

(vi) Training and qualification of all personnel involved in the test program to conduct tests safely and in accordance with operating rules;

(vii) Verification of all emergency preparedness procedures; and,

(viii) Field testing of the railroad's uncertified PTC system and regression testing of its FRA-certified PTC system, under § 299.201.

(c) The railroad shall adopt and comply with the system-wide qualification test plan, including completion of all tests required by the plan.

(d) After FRA review of the system-wide test plan, detailed test procedures as required by paragraph (b) of this section shall be submitted 15 days prior to testing to FRA in accordance with § 299.9 for review.

(e) Each test procedure shall include the following elements:

(1) A clear statement of the test objectives. One of the principal test objectives shall be to demonstrate that the railroad's system meets the safety design and performance requirements specified in this part when operated in the environment in which it will be used;

(2) Any special safety precautions to be observed during the testing;

(3) A description of the railroad property or facilities to be used to conduct the tests;

(4) Prerequisites for conducting each test;

(5) A detailed description of how the tests are to be conducted. This description shall include—

(i) An identification of the systems and equipment to be tested;

(ii) The method by which the systems and equipment shall be tested;

(iii) The instrumentation to be used and calibration procedures;

(iv) The means by which the test results will be recorded, analyzed and reported to FRA;

(v) A description of the information or data to be obtained;

(vi) A description of how the information or data obtained is to be analyzed or used;

(vii) A description of any criteria to be used as safety limits during the testing;

(viii) The criteria to be used to evaluate the systems' and equipments' performance. If system qualification is

to be based on extrapolation of less than full-level testing results, the analysis done to justify the validity of the extrapolation shall be described; and

(ix) Inspection, testing, and maintenance procedures to be followed to ensure that testing is conducted safely.

(f) The railroad shall provide FRA notice at least 30 days in advance of the times and places of any domestic testing and notice at least 90 days in advance for testing not conducted domestically to permit FRA observation of such tests.

#### § 299.605 Functional and performance qualification tests.

The railroad shall conduct functional and performance qualification tests, prior to commencing revenue operations, to verify that all safety-critical components meet all functional and all performance specifications.

#### § 299.607 Pre-revenue service system integration testing.

(a) Prior to commencing revenue operations, the railroad shall conduct tests of the trainsets throughout the system to—

(1) Verify mechanical positioning of the overhead catenary system; and

(2) Verify performance of the trainset, track, and signal and trainset control systems.

(b) The railroad shall demonstrate safe operation of the system during normal and degraded-mode operating conditions. At a minimum, the following operation tests shall be performed:

(1) Slow-speed operation of a trainset;

(2) Verification of correct overhead catenary and pantograph interaction;

(3) Verification of trainset clearance at structures and passenger platforms;

(4) Incremental increase of trainset speed;

(5) Performance tests on trainsets to verify braking rates in accordance with § 299.409;

(6) Verification of vehicle noise;

(7) Verification of correct vehicle suspension characteristics;

(8) Vehicle/track system qualification as defined in § 299.609;

(9) Load tests with vehicles to verify relay settings and signal and communication system immunization;

(10) Monitoring of utility supply circuits and telephone circuits to ensure the adequacy of power supplies, and to verify that transient-related disturbances are within acceptable limits;

(11) Verification of vehicle detection due to shunting of signal system circuits;

(12) Verification of safe operation of the signal and trainset control system as required by subpart B of this part;

(13) Tests of trainset radio reception during system-wide vehicle operation; and

(14) Verification of EMI/EMC compatibility between various subsystems.

**§ 299.609 Vehicle/track system qualification.**

(a) *General.* All vehicles intended to operate in revenue service shall be qualified for operation in accordance with this subpart. A qualification program shall be used to demonstrate that the vehicle/track system will not exceed the wheel/rail force safety limits, and the carbody and bogie acceleration criteria specified in paragraph (h) of this section—

(1) At any speed up to and including 10 km/h (6 mph) above the proposed maximum operating speed; and

(2) On track meeting the requirements for the class of track associated with the proposed maximum operating speed as defined in § 299.309. For purposes of qualification testing, speeds may exceed the maximum allowable operating speed for the class of track in accordance with the test plan approved by FRA.

(b) *New vehicle/track system qualification.* Vehicle types not previously qualified under this subpart shall be qualified in accordance with the requirements of this paragraph (b).

(1) *Carbody acceleration.* For vehicle types intended to operate in revenue service at track class H4 speeds or above, qualification testing conducted over a representative segment of the route shall demonstrate that the vehicle type will not exceed the carbody lateral and vertical acceleration safety limits specified in paragraph (h) of this section.

(2) *Bogie lateral acceleration.* For vehicle types intended to operate at track class H4 speeds or above, qualification testing conducted over a representative segment of the route shall demonstrate that the vehicle type will not exceed the bogie lateral acceleration safety limit specified in paragraph (h) of this section.

(3) *Measurement of wheel/rail forces.* For vehicle types intended to operate at track class H4 speeds or above, qualification testing conducted over a representative segment of the route shall demonstrate that the vehicle type will not exceed the wheel/rail force safety limits specified in paragraph (h) of this section.

(c) *Previously qualified vehicle/track system.* Vehicle/track systems previously qualified under this subpart for a track class and cant deficiency on one route may be qualified for operation at the same class and cant deficiency on

another route through testing to demonstrate compliance with paragraph (a) of this section in accordance with the following:

(1) *Carbody acceleration.* For vehicle types intended to operate at track class H4 speeds and above, qualification testing conducted over a representative segment of the new route shall demonstrate that the vehicle type will not exceed the carbody lateral and vertical acceleration safety limits specified in paragraph (h) of this section.

(2) *Bogie lateral acceleration.* For vehicle types intended to operate at track class H4 speeds or above, measurement of bogie lateral acceleration during qualification testing shall demonstrate that the vehicle type will not exceed the bogie lateral acceleration safety limit specified in paragraph (h) of this section. Measurement of bogie lateral acceleration, if conducted, shall be performed over a representative segment of the new route.

(d) *Vehicle/track system qualification testing plan.* To obtain the data required to support the qualification program outlined in paragraphs (b) and (c) of this section, the railroad shall submit a qualification testing plan as required by § 299.603(b) at least 60 days prior to testing, requesting approval to conduct the testing at the desired speeds and cant deficiencies. This test plan shall provide for a test program sufficient to evaluate the operating limits of the track and vehicle type and shall include—

(1) Identification of the representative segment of the route for qualification testing;

(2) Consideration of the operating environment during qualification testing, including operating practices and conditions, the signal system, and trainset on adjacent tracks;

(3) The maximum angle found on the gauge face of the designed (newly-profiled) wheel flange referenced with respect to the axis of the wheelset that will be used for the determination of the Single Wheel L/V Ratio safety limit specified in paragraph (h) of this section; and

(4) A target maximum testing speed in accordance with paragraph (a) of this section and the maximum testing cant deficiency.

(e) *Qualification testing.* Upon FRA approval of the vehicle/track system qualification testing plan, qualification testing shall be conducted in two sequential stages as required in this subpart.

(1) Stage-one testing shall include demonstration of acceptable vehicle

dynamic response of the subject vehicle as speeds are incrementally increased—

(i) On a segment of tangent track, from acceptable track class H4 speeds to the target maximum test speed; and

(ii) On a segment of curved track, from the speeds corresponding to 76 mm (3 inches) of cant deficiency to the maximum testing cant deficiency.

(2) When stage-one testing has successfully demonstrated a maximum safe operating speed and cant deficiency, stage-two testing shall commence with the subject equipment over a representative segment of the route as identified in paragraph (d)(1) of this section.

(i) A test run shall be conducted over the route segment at the speed the railroad will request FRA to approve for such service.

(ii) An additional test run shall be conducted at 10 km/h (6 mph) above this speed.

(3) When conducting stage-one and stage-two testing, if any of the monitored safety limits are exceeded on any segment of track, testing may continue provided that the track location(s) where any of the limits are exceeded be identified and test speeds be limited at the track location(s) until corrective action is taken. Corrective action may include making adjustments to the track, to the vehicle, or to both of these system components.

(4) Prior to the start of the qualification testing program, a qualifying Track Geometry Measurement System (TGMS) shall be operated over the intended route within 30 calendar days prior to the start of the qualification testing program to verify compliance with the track geometry limits specified in § 299.311.

(f) *Qualification testing results.* The railroad shall submit a report to FRA detailing all the results of the qualification program in accordance with § 299.613. The report shall be submitted at least 60 days prior to the intended operation of the equipment in revenue service over the route.

(g) *Cant deficiency.* Based on the test results and all other required submissions, FRA will approve a maximum trainset speed and value of cant deficiency for revenue service, normally within 45 days of receipt of all the required information. FRA may impose conditions necessary for safely operating at the maximum approved trainset speed and cant deficiency.

(h) *Vehicle/track interaction regulatory limits.* The following vehicle/track interaction regulatory limits shall not be exceeded during qualification testing in accordance with this section.

Table 1 to paragraph (h)			
Vehicle/Track Interaction Safety Limits			
Wheel-Rail Forces <sup>1</sup>			
Parameter	Safety Limit	Filter / Window	Requirements
Single Wheel Vertical Load Ratio	$\geq 0.15$	1.5 m (5 ft)	No wheel of the vehicle shall be permitted to unload to less than 15 percent of the static vertical wheel load for 1.5 m (5 ft) or more continuous meters. The static vertical wheel load is defined as the load that the wheel would carry when stationary on level track.
Single Wheel L/V Ratio	$\leq \frac{\tan(\delta) - 0.5}{1 + 0.5 \tan(\delta)}$	1.5 m (5 ft)	The ratio of the lateral force that any wheel exerts on an individual rail to the vertical force exerted by the same wheel on the rail shall not be greater than the safety limit calculated for the wheel's flange angle ( $\delta$ ) for 1.5 m (5 ft) or more continuous meters.
Net Axle Lateral L/V Ratio	$\leq 0.4 + \frac{22.24}{Va}$	1.5 m (5 ft)	The net axle lateral force, in kN, exerted by any axle on the track shall not exceed a total of 22.24 kN (5 kips) plus 40 percent of the static vertical

			load that the axle exerts on the track for 1.5 m (5 ft) or more continuous meters. $Va$ = static vertical axle load (kN)
Bogie Side L/V Ratio	$\leq 0.6$	1.5 m (5 ft)	The ratio of the lateral forces that the wheels on one side of any bogie exert on an individual rail to the vertical forces exerted by the same wheels on that rail shall not be greater than 0.6 for 1.5 m (5 ft) or more continuous meters.

Carbody Accelerations<sup>2</sup>

Parameter	All Vehicles	Requirements
Carbody Lateral (Transient)	$\leq 0.35g$ peak-to-peak 1 sec window <sup>3</sup> excludes peaks < 50 msec	The peak-to-peak accelerations, measured as the algebraic difference between the two extreme values of measured acceleration in any 1-second time period, excluding any peak lasting less than 50 milliseconds, shall not exceed 0.35g for all vehicles.
Carbody Lateral (Sustained Oscillatory)	$\leq 0.10g$ RMS <sub>t</sub> <sup>4</sup> 4 sec window <sup>3</sup> 4 sec sustained	Sustained oscillatory lateral acceleration of the carbody shall not exceed the prescribed (root mean squared) safety limits of 0.10g for all vehicles. Root mean squared values shall be determined over a sliding 4-second window with linear trend removed and shall be sustained for more than 4 seconds.
Carbody Vertical (Transient)	$\leq 0.45g$ peak-to-peak 1 sec window <sup>3</sup> excludes peaks < 50 msec	The peak-to-peak accelerations, measured as the algebraic difference between the two extreme values of measured acceleration in any one second time period, excluding any peak lasting less than 50 milliseconds, shall not exceed 0.45g for all vehicles.
Carbody Vertical (Sustained Oscillatory)	$\leq 0.16g$ RMS <sub>t</sub> <sup>4</sup> 4 sec window <sup>3</sup> 4 sec sustained	Sustained oscillatory vertical acceleration of the carbody shall not exceed the prescribed (root mean squared) safety limit of 0.16g for all vehicles. Root mean squared values shall be determined over a sliding 4-second window with linear trend removed and shall be sustained for more than 4 seconds.



Bogie Lateral Acceleration <sup>5</sup>			
Parameter	Safety Limit	Filter / Window	Requirements
Bogie Lateral Acceleration	$\leq 0.30g$ RMS <sub>t</sub> <sup>4</sup>	2 sec window <sup>3</sup> 2 sec sustained	Bogie hunting shall not develop below the maximum authorized speed. Bogie hunting is defined as a sustained cyclic oscillation of the bogie evidenced by lateral accelerations exceeding 0.30g root mean squared for more than 2 seconds. Root mean squared values shall be determined over a sliding 2-second window with linear trend removed.

<sup>1</sup> The lateral and vertical wheel forces shall be measured and processed through a low pass filter (LPF) with a minimum cut-off frequency of 25 Hz. The sample rate for wheel force data shall be at least 250 samples per second.

<sup>2</sup> Carbody accelerations in the vertical and lateral directions shall be measured by accelerometers oriented and located in accordance with § 299.331 (c)(3).

<sup>3</sup> Acceleration measurements shall be processed through an LPF with a minimum cut-off frequency of 10 Hz. The sample rate for acceleration data shall be at least 100 samples per second.

<sup>4</sup> RMS<sub>t</sub> = RMS with linear trend removed.

<sup>5</sup> Bogie lateral acceleration shall be measured by accelerometers mounted on the bogie frame at a longitudinal location as close as practicable to an axle's centerline, or if approved by FRA, at an alternate location.

**BILLING CODE 4910-06-C**

**§ 299.611 Simulated revenue operations.**

(a) The railroad shall conduct simulated revenue operations for a minimum period of two weeks prior to revenue operations to verify overall system performance, and provide operating and maintenance experience.

(b) The railroad shall maintain a log of tests conducted during the simulated revenue operations period. This log of tests shall identify any problems encountered during testing, and actions necessary to correct defects in workmanship, materials, equipment, design, or operating parameters.

(c) The railroad shall implement all actions necessary to correct safety defects, as identified by the log prior to the initiation of revenue service.

**§ 299.613 Verification of compliance.**

(a) The railroad shall prepare a report detailing the results of pre-operational qualification, pre-revenue service testing, and vehicle/track system qualification tests required under §§ 299.605, 299.607, and 299.609 respectively. The report shall identify any problems encountered during testing, and alternative actions necessary to correct defects in

workmanship, materials, equipment, design, or operating parameters.

(b) The railroad shall implement all actions necessary to correct defects, as identified by the report.

(c) The railroad shall submit the report(s) required by paragraph (a) of this section to FRA prior to commencing simulated revenue operations and at least 60 days prior to the intended start of full revenue service per § 299.609(f).

(d)(1) Prior to implementing a major upgrade to any safety-critical system component or sub-system, or prior to introducing any new safety-critical technology, the railroad shall submit for FRA approval the detailed test procedures and/or analysis in accordance with § 299.603(d).

(2) The railroad shall prepare a report detailing the results of pre-operational qualification, pre-revenue service testing, and vehicle/track system qualification tests required under §§ 299.605, 299.607, and 299.609 respectively pertaining to a major upgrade to any safety-critical system component or sub-system, or introduction of any new safety-critical technology. The report shall identify any problems encountered during testing, and alternative actions

necessary to correct defects in workmanship, materials, equipment, design, or operating parameters.

**Subpart G—Inspection, Testing, and Maintenance Program**

**§ 299.701 General requirements.**

Under the procedures provided in § 299.713, the railroad shall obtain FRA approval of a written inspection, testing, and maintenance program. The program shall provide detailed information, consistent with the requirements set forth in §§ 299.337 through 299.349, and 299.447(a), on the inspection, testing, and maintenance procedures necessary for the railroad to safely operate its system. This information shall include a detailed description of—

- (a) Safety inspection procedures, intervals, and criteria;
- (b) Test procedures and intervals;
- (c) Scheduled preventive maintenance intervals;
- (d) Maintenance procedures; and
- (e) Special testing equipment or measuring devices required to perform safety inspections and tests.

**§ 299.703 Compliance.**

After the railroad's inspection, testing, and maintenance program is approved

by FRA pursuant to the requirements and procedures set forth in § 299.713, the railroad shall adopt and comply with the program, and shall perform—

(a) All inspections and tests described in the program in accordance with the procedures and criteria that the railroad identified as safety-critical; and

(b) All maintenance tasks and procedures described in the program in accordance with the procedures and intervals that the railroad identified as safety-critical.

**§ 299.705 Standard procedures for safely performing inspection, testing, and maintenance, or repairs.**

(a) The railroad shall establish written standard procedures for performing all safety-critical or potentially hazardous inspection, testing, maintenance, and repair tasks. These standard procedures shall—

(1) Describe in detail each step required to safely perform the task;

(2) Describe the knowledge necessary to safely perform the task;

(3) Describe any precautions that shall be taken to safely perform the task;

(4) Describe the use of any safety equipment necessary to perform the task;

(5) Be approved by the railroad's official responsible for safety;

(6) Be enforced by the railroad's supervisors responsible for accomplishing the tasks; and

(7) Be reviewed annually by the railroad. The railroad shall provide written notice to FRA in accordance with § 299.9 at least one month prior to the annual review. If the Associate Administrator or their designee indicates a desire to be present, the railroad shall provide a scheduled date and location for the annual review. If the Associate Administrator requests the annual review be performed on another date but the railroad and the Associate Administrator are unable to agree on a date for rescheduling, the annual review may be performed as scheduled.

(b) The inspection, testing, and maintenance program required by this section is not intended to address and should not include procedures to address employee working conditions that arise in the course of conducting the inspections, tests, and maintenance set forth in the program. When reviewing the railroad's program, FRA does not intend to review or approve any portion of the program that relates to employee working conditions.

**§ 299.707 Maintenance intervals.**

(a) The initial scheduled maintenance intervals shall be based on those in effect on the Tokaido Shinkansen system as required under § 299.13(c)(1).

(b) The maintenance interval of safety-critical components shall be changed only when justified by accumulated, verifiable operating data, and approved by FRA under paragraph § 299.713.

**§ 299.709 Quality control program.**

The railroad shall establish an inspection, testing, and maintenance quality control program enforced by the railroad or its contractor(s) to reasonably ensure that inspections, testing, and maintenance are performed in accordance with inspection, testing, and maintenance program established under this subpart.

**§ 299.711 Inspection, testing, and maintenance program format.**

The submission to FRA for each identified subsystem shall consist of two parts—

(a) The complete inspection, testing, and maintenance program, in its entirety, including all required information prescribed in § 299.701, and all information and procedures required for the railroad and its personnel to implement the program.

(b) A condensed version of the program that contains only those items identified as safety-critical, per § 299.703 submitted for approval by FRA under § 299.713.

**§ 299.713 Program approval procedure.**

(a) *Submission.* Except as provided in § 299.445(a)(2), the railroad shall submit for approval an inspection, testing, and maintenance program as described in § 299.711(b) not less than 180 days prior to pre-revenue service testing. The program shall be submitted to FRA in accordance with § 299.9. If the railroad seeks to amend an approved program as described in § 299.711(b), the railroad shall file with FRA in accordance with § 299.9 for approval of such amendment not less than 60 days prior to the proposed effective date of the amendment. A program responsive to the requirements of this subpart or any amendment to the program shall not be implemented prior to FRA approval.

(b) *Contents.* Each program or amendment shall contain:

(1) The information prescribed in § 299.701 for such program or amendment;

(2) The name, title, address, and telephone number of the primary person to be contacted with regard to review of the program, its content, or amendments.

(c) *Approval.* (1) Within 90 days of receipt of the initial inspection, testing, and maintenance program, FRA will review the program. The Associate

Administrator will notify the primary railroad contact person in writing whether the inspection, testing, and maintenance program is approved and, if not approved, the specific points in which the program is deficient. Deficiencies identified shall be addressed as directed by FRA prior to implementing the program.

(2) FRA will review each proposed amendment to the program that relaxes an FRA-approved requirement within 45 days of receipt. The Associate Administrator will then notify the primary railroad contact person in writing whether the proposed amendment has been approved by FRA and, if not approved, the specific points in which the proposed amendment is deficient. The railroad shall correct any deficiencies as directed by FRA prior to implementing the amendment. For amendments proposing to make an FRA-approved program requirement more stringent, the railroad is permitted to implement the amendment prior to obtaining FRA approval.

(3) Following initial approval of a program or amendment, FRA may reopen consideration of the program or amendment for cause stated.

(4) The railroad may, subject to FRA review and approval under § 299.15, implement inspection, testing, maintenance procedures and criteria, incorporating new or emerging technology.

**Appendix A to Part 299—Criteria for Certification of Crashworthy Event Recorder Memory Module**

Section 299.439(c) requires that trainsets be equipped with an event recorder that includes a certified crashworthy event recorder memory module. This appendix prescribes the requirements for certifying an event recorder memory module (ERMM) as crashworthy, including the performance criteria and test sequence for establishing the crashworthiness of the ERMM as well as the marking of the event recorder containing the crashworthy ERMM.

**A. General Requirements**

(a) Each manufacturer that represents its ERMM as crashworthy shall, by marking it as specified in section B of this appendix, certify that the ERMM meets the performance criteria contained in this appendix and that test verification data are available to the railroad or to FRA upon request.

(b) The test verification data shall contain, at a minimum, all pertinent original data logs and documentation that the test sample preparation, test set up, test measuring devices and test procedures were performed by designated, qualified individuals using recognized and acceptable practices. Test verification data shall be retained by the manufacturer or its successor as long as the specific model of ERMM remains in service on any trainset.

(c) A crashworthy ERMM shall be marked by its manufacturer as specified in section B of this appendix.

**B. Marking Requirements**

(a) The outer surface of the event recorder containing a certified crashworthy ERMM shall be colored international orange. In addition, the outer surface shall be inscribed, on the surface allowing the most visible area, in black letters on an international orange background, using the largest type size that can be accommodated, with the words “CERTIFIED DOT CRASHWORTHY”, followed by the ERMM model number (or other such designation), and the name of the manufacturer of the event recorder. This information may be displayed as follows:

CERTIFIED DOT CRASHWORTHY  
Event Recorder Memory Module Model  
Number  
Manufacturer’s Name

Marking “CERTIFIED DOT CRASHWORTHY” on an event recorder designed for installation in the railroad’s trainsets is the certification that all performance criteria contained in this appendix have been met and all functions performed by, or on behalf of, the manufacturer whose name appears as part of the marking, conform to the requirements specified in this appendix.

(b) Retro-reflective material shall be applied to the edges of each visible external surface of an event recorder containing a certified crashworthy ERMM.

**C. Performance Criteria for the ERMM**

An ERMM is crashworthy if it has been successfully tested for survival under conditions of fire, impact shock, static crush, fluid immersion, and

hydro-static pressure contained in one of the two tables shown in this section of appendix B. (See Tables 1 and 2.) Each ERMM must meet the individual performance criteria in the sequence established in section D of this appendix. A performance criterion is deemed to be met if, after undergoing a test established in this appendix B for that criterion, the ERMM has preserved all of the data stored in it. The data set stored in the ERMM to be tested shall include all the recording elements required by § 299.439(c). The following tables describe alternative performance criteria that may be used when testing an ERMM’s crashworthiness. A manufacturer may utilize either table during its testing but may not combine the criteria contained in the two tables.

TABLE 1 TO APPENDIX A OF PART 299—ACCEPTABLE PERFORMANCE CRITERIA—OPTION A

Parameter	Value	Duration	Remarks
Fire, High Temperature .....	750 °C (1400 °F) .....	60 minutes .....	Heat source: Oven.
Fire, Low Temperature .....	260 °C (500 °F) .....	10 hours .....	
Impact Shock .....	55g .....	100 ms .....	½ sine crash pulse.
Static Crush .....	110kN (25,000 lbf) .....	5 minutes .....	
Fluid Immersion .....	#1 Diesel, #2 Diesel, Water, Salt Water, Lube Oil. Fire Fighting Fluid .....	Any <i>single</i> fluid, 48 hours .....	
Hydrostatic Pressure .....	Depth equivalent = 15 m. (50 ft.)	10 minutes, following immersion above. 48 hours at nominal temperature of 25 °C (77 °F).	Immersion followed by 48 hours in a dry location without further disturbance.

TABLE 2 TO APPENDIX A TO PART 299—ACCEPTABLE PERFORMANCE CRITERIA—OPTION B

Parameter	Value	Duration	Remarks
Fire, High Temperature .....	1000 °C (1832 °F) .....	60 minutes .....	Heat source: Open flame.
Fire, Low Temperature .....	260 °C (500 °F) .....	10 hours .....	Heat source: Oven.
Impact Shock—Option 1 .....	23gs .....	250 ms .....	
Impact Shock—Option 2 .....	55gs .....	100 ms .....	½ sine crash pulse.
Static Crush .....	111.2kN (25,000 lbf) .....	5 minutes .....	Applied to 25% of surface of largest face.
	44.5kN (10,000 lbf) .....	(single “squeeze”) .....	
Fluid Immersion .....	#1 Diesel, #2 Diesel, Water, Salt Water, Lube Oil, Fire Fighting Fluid.	48 hours <i>each</i> .....	
Hydrostatic Pressure .....	46.62 psig .....	48 hours at nominal temperature of 25 °C (77 °F).	
	(= 30.5 m. or 100 ft.) .....		

**D. Testing Sequence**

In order to reasonably duplicate the conditions an event recorder may encounter, the ERMM shall meet the various performance criteria, described in section C of this appendix, in a set

sequence. (See Figure 1). If all tests are done in the set sequence (single branch testing), the same ERMM must be utilized throughout. If a manufacturer opts for split branch testing, each branch of the test must be conducted using an ERMM of the same design type

as used for the other branch. Both alternatives are deemed equivalent, and the choice of single branch testing or split branch testing may be determined by the party representing that the ERMM meets the standard.

Figure 1 to Appendix A to Part 238 – Event Recorder Memory Module Sequential Testing

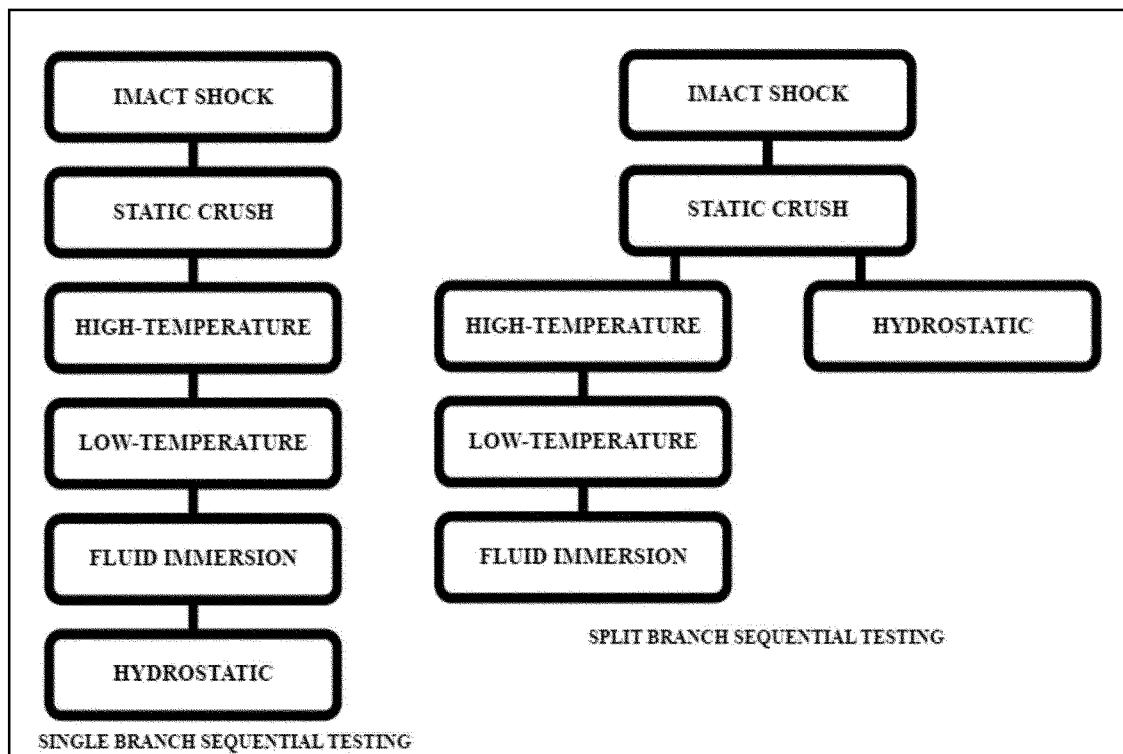

### E. Testing Exception

If a new model ERMM represents an evolution or upgrade from an older model ERMM that was previously tested and certified as meeting the performance criteria contained in section C of this appendix, the new model ERMM need only be tested for compliance with those performance criteria contained in section C of this appendix that are potentially affected by the upgrade or modification. FRA will consider a performance criterion not to be potentially affected if a preliminary engineering analysis or other pertinent data establishes that the modification or upgrade will not change the performance of the older model ERMM against the performance criterion in question. The manufacturer shall retain and make available to FRA upon request any analysis or data relied upon to satisfy the requirements of this paragraph to sustain an exception from testing.

### Appendix B to Part 299—Cab Noise Test Protocol

This appendix prescribes the procedures for the in-cab noise measurements for high-speed trainsets at speed. The purpose of the cab noise testing is to ensure that the noise levels within the cab of the trainset meet the

minimum requirements defined within § 299.437(l).

#### I. Measurement Instrumentation

The instrumentation used shall conform to the requirements prescribed in appendix H to part 229 of this chapter.

#### II. Test Site Requirements

The test shall meet the following requirements:

- (a) The passenger trainset shall be tested over a representative segment of the railroad and shall not be tested in any site specifically designed to artificially lower in-cab noise levels.
- (b) All windows, doors, cabinets, seals, etc., must be installed in the trainset cab and be closed.
- (c) The heating, ventilation and air conditioning (HVAC) system or a dedicated heating or air conditioner system must be operating on high, and the vents must be open and unobstructed.

#### III. Procedures for Measurement

- (a)  $L_{Aeq,T}$  is defined as the A-weighted, equivalent sound level for a duration of T seconds, and the sound level meter shall be set for A-weighting with slow response.
- (b) The sound level meter shall be calibrated with the acoustic calibrator immediately before and after the in-cab tests. The calibration levels shall be recorded.
- (c) Any change in the before and after calibration level(s) shall be less than 0.5 dB.
- (d) The sound level meter shall be located:

(1) Laterally as close as practicable to the longitudinal centerline of the cab, adjacent to the driver's seat,

(2) Longitudinally at the center of the driver's nominal seating position, and

(3) At a height 1219 mm (48 inches) above the floor.

(e) The sound measurements shall be taken autonomously within the cab.

(f) The sound level shall be recorded at the maximum approved trainset speed (0/-3 km/h).

(g) After the passenger trainset speed has become constant at the maximum test speed and the in-cab noise is continuous,  $L_{Aeq,T}$  shall be measured, either directly or using a 1 second sampling interval, for a minimum duration of 30 seconds at the measurement position ( $L_{Aeq, 30s}$ ).

#### IV. Reporting

To demonstrate compliance, the railroad shall prepare and submit a test report in accordance with § 299.613. As a minimum that report shall contain—

- (a) Name(s) of person(s) conducting the test, and the date of the test.
- (b) Description of the passenger trainset cab being tested, including: car number and date of manufacture.
- (c) Description of sound level meter and calibrator, including: make, model, type, serial number, and manufacturer's calibration date.
- (d) The recorded measurement during calibration and for the microphone location during operating conditions.

(e) The recorded measurements taken during the conduct of the test.

(f) Other information as appropriate to describe the testing conditions and procedure.

Issued in Washington, DC.

**Ronald L. Batory,**  
*Administrator.*

[FR Doc. 2020-03521 Filed 3-9-20; 8:45 am]

**BILLING CODE 4910-06-P**