

accidents caused by OSA? With respect to rail, how would any OSA regulations and the current PTC requirements interrelate?

4. Which categories of transportation workers with safety sensitive duties should be required to undergo screening for OSA? On what basis did you identify those workers?

Cost & Benefits

5. What alternative forms and degrees of restriction could FMCSA and FRA place on the performance of safety-sensitive duties by transportation workers with moderate-to-severe OSA, and how effective would these restrictions be in improving transportation safety? Should any regulations differentiate requirements for patients with moderate, as opposed to severe, OSA?

6. What are the potential costs of alternative FMCSA/FRA regulatory actions that would restrict the safety sensitive activities of transportation workers diagnosed with moderate-to-severe OSA? Who would incur those costs? What are the benefits of such actions and who would realize them?

7. What are the potential improved health outcomes for individuals occupying safety sensitive transportation positions and would receive OSA treatment due to regulations?

8. What models or empirical evidence is available to use to estimate potential costs and benefits of alternative restrictions?

9. What costs would be imposed on transportation workers with safety sensitive duties by requiring screening, evaluation, and treatment of OSA?

10. Are there any private or governmental sources of financial assistance? Would health insurance cover costs for screening and/or treatment of OSA?

Screening Procedures & Diagnostics

11. What medical guidelines other than the AASM FAA currently uses are suitable for screening transportation workers with safety sensitive duties that are regulated by FMCSA/FRA for OSA? What level of effectiveness are you seeing with these guidelines?

12. What were the safety performance histories of transportation workers with safety sensitive duties who were diagnosed with moderate-to-severe OSA, who are now successfully compliant with treatment before and after their diagnosis?

13. When and how frequently should transportation workers with safety sensitive duties be screened for OSA? What methods (laboratory, at-home,

split, etc.) of diagnosing OSA are appropriate and why?

14. What, if any, restrictions or prohibitions should there be on a transportation workers' safety sensitive duties while they are being evaluated for moderate-to-severe OSA?

15. What methods are currently employed for providing training or other informational materials about OSA to transportation workers with safety sensitive duties? How effective are these methods at identifying workers with OSA?

Medical Personnel Qualifications & Restrictions

16. What qualifications or credentials are necessary for a medical practitioner who performs OSA screening? What qualifications or credentials are necessary for a medical practitioner who performs the diagnosis and treatment of OSA?

17. With respect to FRA should it use Railroad MEs to perform OSA screening, diagnosis, and treatment?

18. Should MEs or other Agencies' designated medical practitioners impose restrictions on a transportation worker with safety sensitive duties who self-reports experiencing excessive sleepiness while performing safety sensitive duties?

Treatment Effectiveness

19. What should be the acceptable criteria for evaluating the effectiveness of prescribed treatments for moderate-to-severe OSA?

20. What measures should be used to evaluate whether transportation employees with safety sensitive duties are receiving effective OSA treatment?

Rulemaking Analyses and Notices

Executive Order (E.O.) 12866 (Regulatory Planning and Review) and DOT Regulatory Policies and Procedures

Under E.O. 12866, "Regulatory Planning and Review" (issued September 30, 1993, published October 4 at 58 FR 51735, and discussed above in the "Background" section), as supplemented by E.O. 13563 and DOT policies and procedures, if a regulatory action is determined to be "significant," it is subject to Office of Management and Budget (OMB) review. E.O. 12866 defines "significant regulatory action" as one likely to result in a rule that may:

(1) Have an annual effect on the economy of \$100 million or more or adversely affect in a material way the economy, a sector of the economy, productivity, competition, jobs, the environment, public health or safety, or

State, local, or Tribal government or communities.

(2) Create a serious inconsistency or otherwise interfere with an action taken or planned by another Agency.

(3) Materially alter the budgetary impact of entitlements, grants, user fees, or loan programs or the rights and obligations of recipients thereof.

(4) Raise novel legal or policy issues arising out of legal mandates, the President's priorities, or the principles set forth in the E.O.

The Department has determined this ANPRM is a "significant regulatory action" under E.O. 12866, and significant under DOT regulatory policies and procedures due to significant public interest in the legal and policy issues addressed. Therefore, this notice has been reviewed by OMB.

Issued under the authority of delegations in 49 CFR 1.87(f) and (i) and 49 CFR 1.89(a), respectively:

T.F. Scott Darling III,

Acting Administrator, Federal Motor Carrier Safety Administration.

Sarah Feinberg,

Administrator, Federal Railroad Administration.

[FR Doc. 2016-05396 Filed 3-9-16; 8:45 am]

BILLING CODE 4910-EX-P

DEPARTMENT OF TRANSPORTATION

National Highway Traffic Safety Administration

49 CFR Part 571

[Docket No. NHTSA-2016-0029]

RIN 2127-AL68

Federal Motor Vehicle Safety Standards; Electric-Powered Vehicles: Electrolyte Spillage and Electrical Shock Protection

AGENCY: National Highway Traffic Safety Administration (NHTSA), Department of Transportation (DOT).

ACTION: Notice of proposed rulemaking (NPRM).

SUMMARY: NHTSA is proposing to amend Federal Motor Vehicle Safety Standard (FMVSS) No. 305, "Electric-powered vehicles: Electrolyte spillage and electrical shock protection," to adopt various electrical safety requirements in Global Technical Regulation (GTR) No. 13, "Hydrogen and fuel cell vehicles." To expand the standard's performance requirements beyond post-crash conditions, NHTSA proposes to adopt electrical safety requirements to protect against direct and indirect contact of high voltage

sources during everyday operation of electric-powered vehicles. Also, NHTSA proposes to adopt an optional method of meeting post-crash electrical safety requirements consistent with that set forth in GTR No. 13 involving use of physical barriers to prevent direct or indirect contact (by occupants or emergency services personnel) with high voltage sources. Today's proposal would facilitate the introduction of new technologies including hydrogen fuel cell vehicles and 48 volt mild hybrid technologies, and responds not only to GTR No. 13 but also to petitions for rulemaking from Toyota Motor North America Inc. (Toyota) and the Auto Alliance (Alliance).

DATES: Comments must be received on or before May 9, 2016.

Proposed compliance date: We believe there is widespread conformance of vehicles to the proposed requirements. Accordingly, we propose that the compliance date for the amendments in this rulemaking action would be 180 days after the date of publication of the final rule in the **Federal Register**. We propose to permit optional early compliance with the amended requirements.

ADDRESSES: You may submit comments to the docket number identified in the heading of this document by any of the following methods:

- *Federal eRulemaking Portal:* Go to <http://www.regulations.gov>. Follow the online instructions for submitting comments.
- *Mail:* Docket Management Facility, M-30, U.S. Department of Transportation, West Building, Ground Floor, Rm. W12-140, 1200 New Jersey Avenue SE., Washington, DC 20590.
- *Hand Delivery or Courier:* West Building Ground Floor, Room W12-140, 1200 New Jersey Avenue SE., between 9 a.m. and 5 p.m. Eastern Time, Monday through Friday, except Federal holidays.
- *Fax:* (202) 493-2251.

Regardless of how you submit your comments, please mention the docket number of this document.

You may also call the Docket at 202-366-9324.

Instructions: For detailed instructions on submitting comments and additional information on the rulemaking process, see the Public Participation heading of the Supplementary Information section of this document. Note that all comments received will be posted without change to <http://www.regulations.gov>, including any personal information provided.

Privacy Act: Please see the Privacy Act heading under Rulemaking Analyses and Notices.

FOR FURTHER INFORMATION CONTACT: For technical issues, you may call William J. Sanchez, Office of Crashworthiness Standards (telephone: 202-493-0248) (fax: 202-493-2990). For legal issues, you may call Deirdre Fujita, Office of Chief Counsel (telephone: 202-366-2992) (fax: 202-366-3820). Address: National Highway Traffic Safety Administration, U.S. Department of Transportation, 1200 New Jersey Avenue SE., West Building, Washington, DC 20590.

SUPPLEMENTARY INFORMATION:

Table of Contents

- I. Executive Summary
- II. FMVSS No. 305
- III. The Global Technical Regulation
 - a. Overview of the Process
 - b. Overview of GTR No. 13
 1. Electric Safety Requirements During Normal Vehicle Operation
 2. Electric Safety Requirements Post-Crash Test
 - c. How does this proposal differ from GTR No. 13?
- IV. Battelle Study and Developments
- V. Toyota Petition for Rulemaking
- VI. Alliance Petition for Rulemaking
- VII. Overview of Proposed Rule
- VIII. Proposal Addressing Safety During Normal Vehicle Operations
- IX. Proposal Addressing Safety Post-Crash
- X. Rulemaking Analyses and Notices
- XI. Public Participation

I. Executive Summary

NHTSA is issuing this NPRM as part of the agency's ongoing effort to harmonize vehicle safety standards under the Economic Commission for Europe 1998 Global Agreement ("1998 Agreement"). The efforts of the U.S. and other contracting parties to the 1998 Agreement culminated in the establishment of GTR No. 13, "Hydrogen and fuel cell vehicles." NHTSA voted in June 2013 in favor of establishing GTR No. 13. In this NPRM, we are proposing requirements based on the electrical safety requirements of GTR No. 13. NHTSA will initiate rulemaking in the future on other aspects of GTR No. 13 directly pertaining to the fuel system integrity of hydrogen fuel cell vehicles.

One purpose of FMVSS No. 305 is to reduce deaths and injuries from electrical shock. The standard requires vehicles with high voltage sources to meet certain performance criteria to protect vehicle occupants, rescue workers and others who may come in contact with the vehicle after a crash. Among other things, FMVSS No. 305 requires that after a crash, high voltage sources in a vehicle are either (a) electrically isolated from the vehicle's chassis or (b) their voltage is below specified levels considered safe from

electric shock hazards. Since the physiological impacts of direct current (DC) are less than those of alternating current (AC), the standard specifies lower minimum electrical isolation requirements for certain DC components (100 ohms/volt) than for AC components (500 ohms/volt).

GTR No. 13 also has requirements intended to reduce deaths and injuries from electrical shock. Unlike FMVSS No. 305, GTR No. 13 has requirements that reduce the risk of harmful electric shock during normal vehicle operation. This NPRM proposes to adopt those requirements to expand FMVSS No. 305's performance requirements beyond post-crash conditions. In addition, while the various post-crash compliance options in GTR No. 13 are similar to those in FMVSS No. 305, GTR No. 13 includes a compliance option for electrical vehicle safety that prevents direct and indirect contact of high voltage sources by way of "physical barriers." NHTSA is now proposing to amend FMVSS No. 305 to permit a physical barrier compliance option.¹

NHTSA tentatively believes that the by-product of adopting a physical barrier option would be more than harmonizing vehicle standards. Enhanced design innovation, reduced CO₂ emissions and increased fuel economy would likely result. This proposal would facilitate the introduction of 48 volt mild hybrid technologies and hydrogen fuel cell vehicles, and responds not only to GTR No. 13 but also to petitions for rulemaking from Toyota and the Alliance.

Petitioner Toyota believes that an additional compliance option that includes elements of the physical barrier option in GTR No. 13 is needed to allow hydrogen fuel cell vehicles (HFCVs) to be offered for sale in the U.S.² HFCVs and other electric powered

¹ Our proposed physical barrier option varies slightly from GTR No. 13. GTR No. 13 provides contracting parties discretion in whether to propose the option in their domestic regulatory process. In our proposal today, we are not proposing to adopt GTR No. 13's physical barrier option. However, as further discussed, below, we are adopting a modified physical barrier option that we believe will also afford the compliance flexibility that GTR No. 13 seeks to provide, while at the same time providing a level of safety closer to the other post-crash compliance options. A small number of minor additional provisions are proposed as well. These additional provisions would not significantly alter our incorporation of GTR No. 13 and are consistent with the goal of incorporating a standard that is harmonized with other international standards.

² Subsequent to its submission of the petition for rulemaking, Toyota submitted and was granted a temporary exemption from FMVSS No. 305 for an HFCV (see grant of petition, January 2, 2015 (80 FR 101)). Toyota incorporates electrical protection barriers (conductively connected to the electric

vehicles operate with their DC high voltage sources (*e.g.* high voltage battery) connected to the AC high voltage sources (*e.g.* electric motor). In a moderate to severe crash (*e.g.*, crash speeds at which an air bag would deploy), electric powered vehicles are generally designed with an automatic disconnect mechanism that activates and breaks the conductive link between the electrical energy storage system and the rest of the power train. Under these crash conditions in which an automatic disconnect mechanism activates, Toyota states that its HFCVs would be able to meet the electrical safety requirements of FMVSS No. 305. However, in low speed crashes where the automatic disconnect mechanism is not designed to activate so that the vehicle can be driven away after a minor crash (fender-bender), Toyota states that its HFCVs would not be able to meet the electrical safety requirements in FMVSS No. 305. The petitioner believes that the additional compliance option requested in its petition would solve this problem and would not cause any reduction in the level of electrical safety now required by FMVSS No. 305.

Petitioner Alliance requests a physical barrier compliance option to facilitate the production of 48 volt mild hybrid technologies as well as hydrogen fuel cell vehicles. The petitioner asks NHTSA to amend FMVSS No. 305 to adopt a physical barrier option incorporated in the Society of Automotive Engineers (SAE) J1766 Jan 2014,³ section 5.3.4, for 48 volt mild hybrid systems. The Alliance believes that the provisions for physical barriers in section 5.3.4 incorporate the requirements of GTR No. 13 and provide for physical barriers that ensure equal levels of safety as that afforded by the current FMVSS No. 305 electrical safety requirements.

The petitioner states that while vehicles with 48 volt mild hybrid systems use mostly low-voltage components that do not present any danger of harmful electric shock, AC voltage sources contained within the system can exceed the 30 volt threshold in FMVSS No. 305 for consideration as a high voltage source. Since these systems are grounded to the vehicle chassis, they cannot meet FMVSS No.

chassis with low resistance) and maintains at least a 100 ohms/volt electrical isolation into their design. NHTSA granted the petition for exemption on the basis that the exemption would make the development or field evaluation of a low emission (zero emission) vehicle easier and would not unreasonably reduce the safety of the vehicle.

³ SAE J1766, "Recommended practice for electric, fuel cell, and hybrid electric vehicle crash integrity testing," January 2014, SAE International, <http://www.sae.org>.

305's existing electrical isolation option. The petitioner states that while it is feasible to design a 48 volt mild hybrid system that is isolated from the chassis and meets FMVSS No. 305's electrical isolation requirements, such designs involve more complexity, higher consumer costs, and higher mass resulting in reduced fuel economy and increased emissions. The petitioner believes that these penalties are inappropriate when there would be no incremental safety benefit gained beyond that associated with SAE J1766's physical barrier option.

NHTSA has undertaken this rulemaking after carefully and extensively examining the safety issues. The agency previously decided against consideration of a physical barrier option earlier in the history of FMVSS No. 305, when our knowledge about the option was limited.⁴ Commenters to an NPRM to upgrade electrical shock protection requirements had asked NHTSA to adopt the option in the final rule, for reasons similar to those provided by petitioners Toyota and the Alliance. NHTSA declined, citing concerns about the lack of notice for the provision, the absence of developed test procedures to ensure protection from indirect contact, and uncertainty as to whether the option would sufficiently account for indirect contact failure modes. NHTSA then decided to undertake a research program (later known as the Battelle study, discussed below in this preamble) to better understand the issues related to a physical barrier option for electrical safety.

Since that decision in 2010, a number of developments led to today's proposal. GTR No. 13 was established, a product of shared data and knowledge from governing bodies and international experts around the world. The Battelle study was completed and the physical barrier countermeasure design was made more robust in response to its findings, with SAE revising J1766 in January 2014 to set forth more protective safety practices than it had before to address remote albeit lingering concerns. Importantly, there have now been years of worldwide recognition of the physical barrier option as an acceptable means of providing electrical safety in electric powered vehicles, with years of experience in design labs and in the field showing no evidence of associated safety problems. HFCVs, 48 volt mild hybrid technologies, and other vehicle designs have become a reality,

⁴ See final rule, 75 FR 33515, June 14, 2010; response to petitions for reconsideration, 76 FR 45436, July 29, 2011.

and with them abundant potential for the development of electrical technologies that a physical barrier option in FMVSS No. 305 can facilitate, expedite and safeguard.

We estimate that adopting this NPRM would come at essentially no cost to consumers in the U.S. This proposal closely mirrors the electrical safety provisions of GTR No. 13, which have been implemented by manufacturers in this country.

NHTSA believes that this NPRM would improve the level of safety afforded to the public. Adopting the provisions from GTR No. 13 that reduce the risk of harmful electric shock during normal vehicle operation would improve FMVSS No. 305 by expanding its performance requirements beyond post-crash conditions. The proposed requirements would provide post-crash compliance options for new power train configurations that ensure that those configurations provide a comparable level of post-crash safety compared to existing electric vehicles.

Summary of Proposal

The proposed amendments are summarized as follows. In furtherance of implementing GTR No. 13 and in response to the petitions for rulemaking—

a. This NPRM proposes to add electrical safety requirements for vehicle performance during everyday ("normal") vehicle operations (as opposed to during and after a crash), to mitigate electric shock due to loss in electrical isolation and direct or indirect contact of high voltage sources. The electrical safety requirements during normal vehicle operations would include requirements for:

1. Direct contact protection from high voltage sources

i. IPXXD protection level⁵ for high voltage sources inside passenger and luggage compartments. IPXXB protection level for high voltage sources not in passenger and luggage compartments.

ii. IPXXB protection level for service disconnect that can be opened or removed without tools.

iii. Markings on barriers of high voltage sources that can be physically accessed, opened, or removed without the use of tools.

⁵ IPXXB and IPXXD "protection levels" refer to the ability of the physical barriers to prevent entrance of a probe into the enclosure, to ensure no direct contact with high voltage sources. "IPXXB" is a probe representing a small human finger. "IPXXD" is a slender wire probe. Protection degrees IPXXD and IPXXB are International Electrotechnical Commission specifications for protection from direct contact of high voltage sources.

iv. Orange color outer covering for cables of high voltage sources that are located outside electrical protection barriers.⁶

2. Indirect contact protection from high voltage sources

Exposed conductive parts of electrical protection barriers would have to be conductively connected to the chassis with a resistance less than 0.1 ohms, and the resistance between two simultaneously reachable exposed conductive parts of electrical protection barriers that are within 2.5 meters of each other would have to be less than 0.2 ohms.

3. Electrical isolation of high voltage sources

i. 500 ohms/volt or higher electrical isolation for AC high voltage sources and 100 ohms/volt or higher for DC high voltage sources.

ii. For conditions where AC and DC bus are connected, AC high voltage sources would be permitted to have electrical isolation of 100 ohms/volt or higher, provided they also have the direct and indirect contact protection described in 1 and 2, above.

iii. There would be an exclusion of 48 volt hybrid vehicles from electrical isolation requirements during normal vehicle operation.

4. Electrical isolation monitoring system for DC high voltage sources on fuel cell vehicles.

5. Electrical safety during charging involving connecting the vehicle to an external electric power supply:

i. Minimum electrical isolation resistance of one million ohm of the coupling system for charging the electrical energy storage system; and

ii. Conductive connection of the electric chassis to earth ground before and during exterior voltage is applied.

6. Mitigating driver error by—

i. Requiring an indication to the driver when the vehicle is in active driving mode upon vehicle start up and when the driver is leaving the vehicle; and

ii. Preventing vehicle movement by its own propulsion system when the vehicle charging system is connected to the external electric power supply.

b. This NPRM also proposes to amend FMVSS No. 305's post-crash electrical safety requirements. The proposed post-crash electrical safety requirements include:

1. Adding an additional optional method of meeting post-crash electrical safety requirements through physical barrier protection from high voltage sources. The proposed specifications of this optional method of electric safety include requirements ensuring that:

i. High voltage sources would be enclosed in barriers that prevent direct human contact with high voltage sources (IPXXB protection level),

ii. Exposed conductive parts of electrical protection barriers would be conductively connected to the chassis with a resistance less than 0.1 ohms, and the resistance between any two simultaneously reachable exposed conductive parts of electrical protection barriers that are less than 2.5 meters from each other would be less than 0.2 ohms, and

iii. Voltage between a barrier and other exposed conductive parts of the vehicle would be at a low voltage level that would not cause electric shock (less than 60 VDC⁷ or 30 VAC).

2. Permitting an AC high voltage source that is conductively connected to a DC high voltage source to meet lower minimum electrical isolation requirement of 100 ohms/volt, provided the AC high voltage source also has physical barrier protection specified in 1, above.

II. FMVSS No. 305

FMVSS No. 305 currently establishes requirements to reduce deaths and injuries during and after a crash that occurs because of electrolyte spillage from electric energy storage devices, intrusion of electric energy storage/conversion device into the occupant compartment, and electrical shock. Among other things, FMVSS No. 305 requires that during and after the crash tests specified in the standard, high voltage sources in the vehicle must be either (a) electrically isolated from the vehicle's chassis,⁸ or (b) their voltage is below specified levels considered safe from electric shock hazards.⁹

Many of these electrical shock protection requirements were established by a June 14, 2010 final rule (75 FR 33515) that revised the standard to align it more closely with the April 2005 version of SAE J1766. Commenters to the NPRM preceding the June 14, 2010 final rule (*viz.*, the Alliance and Global Automakers) requested another electrical safety compliance option, called the "physical barrier option," for providing greater flexibility to allow

⁷ VDC is the voltage for direct current sources and VAC is voltage for alternating current sources.

⁸ Under this electrical isolation option, since the physiological impacts of DC are less than those of AC, the standard permits DC high voltage sources with an electrical isolation monitoring system to have lower minimum electrical isolation (100 ohms/volt) than the 500 ohms/volt required for AC high voltage sources. This level of electrical isolation limits the current that could pass through a human body (that is in contact with the vehicle) to no more than 10 milliamperes (mA) DC or 2 mA AC. These levels are considered to be safe levels of current and would not cause any tissue damage, or fibrillation.

⁹ Under this low voltage option, electrical components are considered to be low voltage and safe from electric shock hazard if their voltage is less than or equal to 60 VDC or 30 VAC.

introduction of advanced power train technologies. In the physical barrier option, high voltage sources are enclosed in physical barriers (electrical protection barriers) that do not permit entrance of a finger probe into the enclosure after the crash test to ensure no direct contact with high voltage sources. This option also requires the physical barriers to be conductively connected to the electric chassis to ensure no electric shock due to indirect contact in the event of loss in isolation of a high voltage source.

In the June 14, 2010 final rule, NHTSA declined to adopt the physical barrier option, citing concerns about the sufficiency of notice provided for the provision, the absence of developed test procedures to ensure protection from indirect contact, and uncertainty as to whether the option would sufficiently account for indirect contact failure modes. NHTSA stated that it would undertake a research program (the Battelle study) to better understand the issues related to a physical barrier option for electrical safety.

III. The Global Technical Regulation

a. Overview of the Process

The United States is a contracting party to the "1998 Agreement" (the Agreement concerning the Establishing of Global Technical Regulations for Wheeled Vehicles, Equipment and Parts which can be fitted and/or be used on Wheeled Vehicles). This agreement entered into force in 2000 and is administered by the UN Economic Commission for Europe's (UN ECE's) World Forum for the Harmonization of Vehicle Regulations (WP.29). The purpose of this agreement is to establish Global Technical Regulations (GTRs).

GTR No. 13, "Hydrogen fuel cell vehicles," addresses hydrogen fuel cell vehicle technology. NHTSA closely collaborated with experts from contracting parties to the 1998 Agreement, particularly Germany and Japan, to develop a GTR for hydrogen fueled vehicles that would establish levels of safety that are equivalent to or exceeds those for conventional gasoline fueled vehicles. The collaborative effort in this process led to the establishment of GTR No. 13 in June 2013.

The U.S. voted on June 27, 2013 in favor of establishing GTR No. 13. In voting yes to establishing the GTR, NHTSA is obligated to "submit the technical Regulation to the process" used in the U.S. to adopt the requirement into our law or regulation. By issuance of this NPRM, NHTSA is initiating the process for considering adoption of GTR No. 13.

⁶ An electrical protection barrier is defined in GTR No. 13 as the part providing protection from direct contact with high voltage sources from any direction of access. These may be physical barriers that enclose high voltage sources.

Under the terms of the 1998 Agreement, NHTSA is not obligated to adopt the GTR after initiating this process. In deciding whether to adopt a GTR as an FMVSS, we follow the requirements for NHTSA rulemaking, including the Administrative Procedure Act, the National Highway and Motor Vehicle Safety Act (Vehicle Safety Act), Presidential Executive Orders, and DOT and NHTSA policies, procedures and regulations. Among other things, FMVSSs issued under the Vehicle Safety Act “shall be practicable, meet the need for motor vehicle safety, and be stated in objective terms.” 49 U.S.C. 30111.

This NPRM does not propose the entirety of GTR No. 13 at this time. This document only addresses the electrical safety requirements in GTR No. 13 (*i.e.*, the electrical isolation requirements, physical barrier requirements, etc.). GTR No. 13 also addresses hydrogen fuel system and fuel container integrity requirements and the agency’s plan is to issue a separate proposal to seek comment on incorporating those portions of GTR No. 13 into the relevant FMVSSs.

b. Overview of GTR No. 13

Hydrogen fueled fuel cell vehicles have an electric drive-train powered by a fuel cell that generates electric power electrochemically using hydrogen. The hydrogen is electrochemically combined with oxygen (from air) within the fuel cell system to produce high-voltage electric power. The electric power is supplied to the electric drive motors and/or used to charge batteries and capacitors. HFCVs may also be equipped with batteries to supplement the output of fuel cells and may also recapture energy during stopping through regenerative braking, which recharges batteries and thereby improves efficiency.

The fuel cell provides DC power while the drive motors typically operate on AC. Therefore, the power train has: (a) Inverters to convert DC power to AC to run the motors and (b) converters to convert AC power generated in the drive motor during regenerative braking to DC to store energy in the batteries. In many respects, the electric power train of an HFCV is similar to that of electric and hybrid electric vehicles. GTR No. 13, in part, specifies electrical safety requirements during normal vehicle operation and after a crash test, to protect against electric shock in the event of a failure in the high voltage propulsion system.

In general, the portions of GTR No. 13 that are relevant to this rulemaking are the electric safety requirements intended to protect against the potential for electric shock during (a) normal vehicle operation, and (b) after a crash. We discuss these requirements in GTR No. 13 in the sections below.

1. Electric Safety Requirements During Normal Vehicle Operation

These performance requirements in GTR No. 13 are requirements intended for protecting vehicle occupants (and others that may interact with the vehicle) against electric shock during normal vehicle operation.¹⁰ For the purposes of the GTR, normal vehicle operations include those during driving and charging.

The GTR requirements apply to all high voltage sources (electric components contained or connected to the electric power train that have a working voltage greater than 30 VAC or 60 VDC). It requires these high voltage sources to have all four of the following measures to protect against electric shock during normal vehicle operations: (1) Prevent direct contact of high voltage sources (those operating with voltage greater than 30 VAC or 60 VDC); (2)

prevent indirect contact of high voltage sources; (3) electrically isolate the high voltage sources from the electric chassis (500 ohms/volt or higher for AC and 100 ohms/volt or higher for DC sources); and (4) electrical isolation monitoring system for HFCVs that warns the driver in the event of loss in isolation.

The GTR also has the following measures to reduce driver errors that may result in potential unsafe conditions: (1) Indication to the driver when the vehicle is in possible active driving mode at startup and when the driver is leaving the vehicle, and (2) prevent vehicle movement by its own propulsion system when the vehicle charging system is connected to the external electric power supply.

Protection Against Direct Contact With High Voltage Sources

For protection against direct contact with high voltage sources, the GTR has different requirements based on the location of the high voltage source (*i.e.*, if it is in the passenger or luggage compartment of the vehicle or not).

The GTR requires high voltage sources inside the passenger compartment or luggage compartment to be enclosed in protection systems such as solid insulators, electrical protection barriers, and enclosures that cannot be opened, disassembled, or removed without the use of tools and that provide protection degree IPXXD. Protection degree IPXXD is an International Electrotechnical Commission (IEC) specification for protection from direct contact of high voltage sources. IPXXD protection is verified when a standard probe (rigid test wire shown in Figure 1), 100 millimeters (mm) long and 1 millimeter (mm) in diameter, does not contact high voltage components when probed to enter an electrical protection barrier or enclosure.¹¹

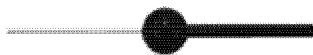

Figure 1. Standardized test wire (IPXXD)

For high voltage sources not in passenger or luggage compartments,¹² the GTR requires that they be enclosed in protection systems such as solid

insulators, electrical protection barriers, and enclosures that cannot be opened, disassembled, or removed without the use of tools, and that provide a

protection degree of IPXXB (as opposed to IPXXD, referenced above). Protection degree IPXXB is an IEC specification for protection from direct contact of high

¹⁰ In other words, the focus of this “in-use” testing (unlike “post-crash” testing, discussed later) deals with performance criteria that would be assessed without first exposing the vehicle to a crash test. This testing is aimed at evaluating what

the performance of the vehicle would be under normal operating conditions.

¹¹ IEC60529 Second edition 1989–11 + Am. 1 1999–11, EN60529, “Degrees of protection provided by enclosures.”

¹² GTR No. 13 specifies direct contact protection requirements for high voltage connectors (including vehicle inlet) separately.

voltage sources. IPXXB protection is verified when a standard probe (resembling a small human finger), 80

mm long and 12 mm in diameter, does not contact high voltage components when probed to enter an electrical

protection barrier or enclosure.¹³ (See Figure 2 below.)

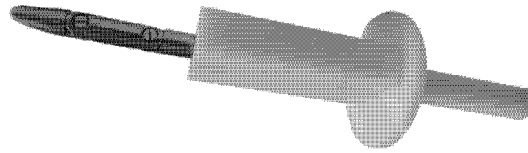

Figure 2. Standardized test finger (IPXXB)

In addition to barriers preventing direct physical contact with high voltage sources, GTR No. 13 also requires protections for the “service disconnect.”¹⁴ These provisions protect emergency personnel, persons performing service/maintenance on the vehicle, and vehicle occupants. The GTR requires that a service disconnect (which can be opened, disassembled or removed without tools) be enclosed by protection systems with protection

degree IPXXB when the service disconnect is opened, disassembled, or removed.

Further, the GTR requires that high voltage sources be labeled using the symbol shown in Figure 3, below. The interior of the symbol is yellow and the border and arrow symbol are black. This requirement aims to provide a standardized warning regarding the presence of high voltage sources within an enclosure that can be physically

accessed, opened or removed without the use of tools. The GTR specifies that the labels need to be on or near electric energy storage/conversion devices and on electrical protection barriers or enclosures of high voltage sources that can be physically accessed, opened, or removed without the use of tools and that are not located underneath the vehicle floor. For connectors of high voltage sources, the GTR makes this requirement optional.

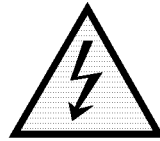

Figure 3. Marking of high voltage sources

In the same vein, the GTR requires cables to have a standardized warning that high voltage cables are present. The GTR requires that cables for high voltage sources, which are not located within enclosures, must have an orange outer covering for identification.

Protection Against Indirect Contact With High Voltage Sources

Indirect contact of high voltage sources¹⁵ may occur when a high voltage source experiences a loss in electrical isolation and the physical barrier or enclosure gets electrically energized. This type of contact could also lead to electrical shock. To address

this concern, the GTR requires, first, that exposed conductive parts (parts which may become electrically energized under electrical isolation failure and which can be contacted by a human, such as electrical protection barriers and enclosures) be conductively connected to the electrical chassis such that the resistance between all exposed conductive parts and the electrical chassis is less than 0.1 ohms when there is current flow of at least 0.2 amperes (A).¹⁶ This would ensure that in the event of loss in electrical isolation, no dangerous voltage potentials are produced between exposed conductive parts and the electrical chassis, and

therefore very low levels of current would flow through a human body contacting different parts of the vehicle.¹⁷

Second, GTR No. 13 requires that vehicles whose rechargeable energy storage systems are charged by conductively connecting to an external grounded electric power supply have a device that conductively connects the electrical chassis to the earth ground during charging. This ensures that if there is a loss in electrical isolation of a high voltage source during charging and the vehicle chassis is contacted by a human, the magnitude of current

¹³ IEC60529 Second edition 1989–11 + Am. 1 1999–11, EN60529, “Degrees of protection provided by enclosures.” This test probe designed to simulate a small human finger (12 mm) conforms to ISO 20653 “Road vehicles—Degrees of protection (IP-Code)—Protection of electrical equipment against foreign objects, water, and access (IPXXB).”

¹⁴ A service disconnect is a device for deactivation of an electrical circuit when

conducting checks and services of the electric battery, fuel cell stack, or other high voltage sources.

¹⁵ Contact of a conductive part which is energized due to loss in electrical isolation of a high voltage source is an indirect contact of the high voltage source.

¹⁶ GTR No. 13 considers this requirement to be met if visual inspection indicates that a conductive

connection has been established by welding. NHTSA has concerns about this provision and is requesting comments on it.

¹⁷ Since current flows through the path of least resistance, most of the current flow would be through the chassis rather than through the human body which has a significantly higher resistance.

flowing through the person is very low and in the safe zone.¹⁸

Protection by Electrical Isolation

GTR No. 13 affords different electrical isolation requirements for AC and DC high voltage sources based on whether they are conductively isolated from each other or conductively linked together.

For AC and DC high voltage sources that are conductively isolated from each other, GTR No. 13 requires isolation resistance between the high voltage source and the electrical chassis to be a minimum value of 100 ohms/volt of the working voltage for DC high voltage sources, and a minimum value of 500 ohms/volt of the working voltage for AC high voltage sources. This requirement is similar to the post-crash electrical isolation requirement currently in FMVSS No. 305. It ensures that in the event high voltage sources are contacted, the current flowing through the body is less than or equal to 10 mA DC or 2 mA AC—which is considered to be safe.¹⁹

For AC and DC high voltage sources that are conductively connected, GTR No. 13 affords two options. The first option is the vehicle may maintain an isolation resistance between the high voltage sources and the electrical chassis at no less than 500 ohms/volt of the working voltage. The second option is it may provide an isolation resistance between the high voltage sources and the electrical chassis of no less than 100 ohms/volt of the working voltage and provide physical barrier protection for the AC high voltage sources to prevent both direct and indirect contact, as discussed above. (Note that a “physical barrier” approach would be a new concept in FMVSS No. 305.)

In addition, GTR No. 13 specifies electrical isolation requirements for charging electric vehicles whose rechargeable energy storage system are charged by conductively connecting to an external power supply. GTR No. 13 requires that the isolation resistance between the electrical chassis and high voltage sources conductively connected to the vehicle inlet which connects to the external power supply to be at least 1 million (M) ohms when the charge coupler is disconnected. This requirement is in accordance with

¹⁸ Current will flow through the path of least resistance and therefore most of the current resulting from a loss of electrical isolation would flow through the ground connection rather than through the human body.

¹⁹ See IEC TS 60479-1 and TS 60479-2 Effects of Current on Human Beings and Livestock—Part 1: General Aspects, 2005-07, Reference Nos. CEI/IEC/TS 60479-1:2005.

IEC61851-1-2010²⁰ and International Standards Organization (ISO) 6469-2²¹ which prescribe electrical isolation for electric vehicles that connect to the power grid for charging. A typical minimum allowable isolation requirement for a grounded product connected to the power grid is 1000 ohms/volt, which computes to 1M ohms.

Protection by Electrical Isolation Monitoring System

GTR No. 13 also contains provisions for monitoring the electrical isolation under certain conditions. In fuel cell vehicles, GTR No. 13 requires DC high voltage sources (other than the coupling system for charging) to have an on-board electrical isolation monitoring system, together with a warning to the driver if the isolation resistance drops below the minimum required value of 100 ohms/volt. FMVSS No. 305 specifies a similar requirement except that FMVSS No. 305 applies this provision to vehicles that are certified to the 100 ohms/volt electrical isolation option²² (rather than to fuel cell vehicles specifically).

Protection by Mitigating Driver Error

GTR No. 13 also has provisions for mitigating the likelihood of driver error in operating electric vehicles. First, GTR No. 13 requires that at least a momentary indication be given to the driver when the vehicle is in possible active driving mode.²³ Second, when leaving the vehicle, the driver shall be informed by an optical or audible signal if the vehicle is still in possible active driving mode. The third requirement is that for vehicles where the on-board rechargeable energy storage/conversion device can be charged externally, vehicle movement by its own propulsion system shall not be possible when the external electric power supply is physically connected to the vehicle inlet.

²⁰ IEC 61851-1:2010 Electric vehicle conductive charging system—Part 1: General requirements, available at <https://webstore.iec.ch/publication/6029>.

²¹ ISO 6469-2:2009 Electrically propelled road vehicles—Safety specifications—Part 2: Vehicle operational safety means and protection against failures. Available at http://www.iso.org/iso/catalogue_detail?csnumber=45478.

²² As discussed above, AC high voltage sources are required under FMVSS No. 305 to have at least 500 ohms/volt of electrical isolation. DC high voltage sources may have an electrical isolation of 100 ohms/volt or greater provided that they meet conditions such as having an electrical isolation monitoring system meeting the requirements of the standard.

²³ *I.e.*, the vehicle mode when application of pressure to the accelerator pedal or release of the brake system causes the electric power train to move the vehicle.

The first requirement does not apply to vehicles with an internal combustion engine that directly or indirectly provides the vehicle’s propulsion on startup. Since electric powered vehicles operate quietly, an indication of the vehicle in possible active driving mode would assist the driver in reducing operational errors that could have safety implications. The third requirement prevents the charger from getting ripped out of the vehicle inlet during charging that could cause electrical arcing.

2. Electric Safety Requirements Post-Crash Test

The post-crash²⁴ electrical safety requirements in GTR No. 13 apply to all high voltage sources (electric components contained or connected to the electric power train that have a working voltage greater than 30 VAC or 60 VDC). GTR No. 13 does not specify the type of crash test and how it is conducted. This is left to each contracting party to develop appropriate crash tests. After the crash test, to provide adequate protection against electric shock, GTR No. 13 affords three potential options that a vehicle manufacturer may use to protect against potential human contact with high voltage sources. GTR No. 13 specifically gives contracting parties the choice not to provide the physical barrier option in their final domestic regulation.

Reduce the Voltage Levels of the High Voltage Sources Such That They Are No Longer High Voltage Sources

Reducing the high voltage sources’ voltage to a level below what is considered a “high voltage source” means there is no further need to protect against electrical shock from those sources. Thus, in this option, GTR No. 13 requires that the voltages of each high voltage source be reduced to less than or equal to 30 VAC or 60 VDC within 60 seconds after the impact. A version of this option for electrical safety is currently in FMVSS No. 305.

Use a Physical Barrier and Other Techniques To Prevent Direct/Indirect Contact²⁵ With High Voltage Sources

The physical barrier option protects against electrical shock by preventing

²⁴ In terms of “post-crash” we are referring to assessing a vehicle’s electrical safety provisions (electrical isolation, physical barrier, etc.) after the vehicle is exposed to specified crash forces in a crash test. This is different from the aforementioned “in-use” (or “normal operating conditions”) requirements where the vehicle is evaluated for conformance with a performance requirement without first being exposed to crash testing.

²⁵ To reiterate, this option is one that contracting parties may choose not to propose. In other words,

any human contact (direct or indirect) with the high voltage sources. The physical barrier option for post-crash is similar to the physical barrier option that GTR No. 13 affords for its normal vehicle operation requirement. The requirements state that (post-crash) the vehicle needs to prevent both direct and indirect human contact with high voltage sources through the use of: (1) Physical barriers (*i.e.*, prevent a finger probe test device from contacting any high voltage source); and (2) low resistance conductive connection of the physical barriers to the electrical chassis (*i.e.*, the resistance between all exposed conductive parts and the electrical chassis has to be less than 0.1 ohms when there is a current flow of at least 0.2 A²⁶). The only major difference is that GTR No. 13 uses protection degree IPXXB (*i.e.*, the IPXXB finger probe) for its post-crash requirements (rather than IPXXD).²⁷ As noted earlier, FMVSS No. 305 currently contains no similar provision for electric shock protection through physical barriers.

Electrically Isolate the High Voltage Sources

This option protects against electric shock by ensuring that a sufficient level of electrical isolation resistance is provided for the high voltage source. GTR No. 13 provides two different sets of requirements (based on whether the vehicle's AC and DC high voltage sources are conductively connected) for vehicles electing to use this option to protect against electric shock.

If the AC and DC high voltage sources are conductively isolated from each other, then the minimum electrical isolation of a high voltage source to the chassis is 500 ohms/volt for AC components and 100 ohms/volt for DC components of the working voltage.

If AC and DC high voltage sources are conductively connected, GTR No. 13 requires that electrical isolation of AC and DC high voltage sources be no less than 500 ohms/volt of the working voltage, or the electric isolation of those sources be no less than 100 ohms/volt

a contracting party that voted in favor of this GTR may submit this GTR to their domestic rulemaking process affording only two options for protecting against post-crash electrical shock (*i.e.*, reducing the high voltage sources' voltage so that they are no longer considered high voltage; and maintaining the required levels of electrical isolation of the high voltage sources).

²⁶ GTR No. 13 considers this requirement to be met if visual inspection indicates that conductive connection has been established by welding. The minimum resistance requirement is only evaluated in case of doubt.

²⁷ Here the post-crash requirements in the GTR use IPXXB because it is assumed unlikely that, post-crash, someone would use a wire to probe the enclosure.

provided that the AC high voltage sources (in addition to the minimum 100 ohms/volt electrical isolation) meet the reduced voltage level requirements discussed above (first option), or meet the physical protection requirements discussed above in the second option.

We note that while currently FMVSS No. 305 contains different requirements for AC high voltage sources and DC high voltage sources, it does not distinguish requirements based on whether the AC and DC high voltage sources are conductively linked. Thus, while the requirements in GTR No. 13 for AC and DC sources that are not conductively connected are the same as those currently in FMVSS No. 305, the alternative requirements for conductively connected AC and DC sources are not.

c. How does this proposal differ from GTR No. 13?

This NPRM proposes to add electrical safety requirements during normal vehicle operation in GTR No. 13 into FMVSS No. 305. The proposal also adds a modified version of physical barrier protection that is specified in GTR No. 13 as a compliance option for meeting post-crash electrical safety requirements. However, this NPRM does not propose to adopt all the specifications in GTR No. 13. The differences in electrical safety requirements and associated test procedures in the proposal and that in GTR No. 13, along with an explanation for these differences, are provided below. Comments are requested on NHTSA's views.

Physical Barrier Protection During Normal Vehicle Operation

This NPRM proposes to adopt GTR No. 13's physical barrier protection requirement during normal vehicle operation for direct contact. However, for indirect contact protection, we propose to use the proposed post-crash indirect contact protection requirements described above (which include two additional requirements described above in addition to that specified in GTR No. 13).

Verification of Physical Barrier Protection During Normal Vehicle Operations

GTR No. 13 considers indirect contact protection requirements during normal vehicle operations to be met if a galvanic connection²⁸ has been established by welding between

²⁸ A galvanic connection is a conductive connection.

exposed conductive parts and the electrical chassis.

For conditions where the DC and AC high voltage sources are connected during normal vehicle operations, GTR No. 13 permits the AC high voltage sources to have a minimum electrical isolation of 100 ohms/volt provided the AC high voltage sources have either: (a) Double or more layers of solid insulators or electrical protection barriers that meet the requirements for indirect contact protection; or (b) Mechanically robust protections that have sufficient durability over vehicle service life such as motor housings, electronic converter cases or connectors.

These methods of verification consist of mere visual inspection and do not provide sufficient objectivity for use in an FMVSS. Therefore, the agency's proposal does not consider indirect contact protection requirements to be met if galvanic connection has been established between exposed conductive parts and the electric chassis. The agency is also not proposing visual inspection methods to permit AC high voltage sources that are connected to a DC high voltage source to have minimum electrical isolation of 100 ohms/volt during normal vehicle operation.

High Voltage Markings

GTR No. 13 requires marking (yellow high voltage symbol) for enclosures and barriers of high voltage sources (electrical protection barriers) that can be physically accessed, opened, or removed without the use of tools. These markings are not required for electrical protection barriers located underneath the vehicle floor.

NHTSA tentatively concludes that the exclusion is without merit. GTR No. 13 does not provide a justification for exempting electrical protection barriers located underneath the vehicle floor from the high voltage marking requirement. There is also no definition of "vehicle floor" in GTR No. 13. NHTSA does not believe electrical protection barriers located under the vehicle floor should be excluded because it is possible that the high voltage sources enclosed by these barriers may be accessed in a rollover crash or during vehicle maintenance.

Direct Contact Protection of Connectors

GTR No. 13 specifies direct contact protection requirements for high voltage connectors separately. Per GTR No. 13, connectors do not need to meet IPXXB protection if they are located underneath the vehicle floor and are provided with a locking mechanism, or require the use of tools to separate the

connector, or the voltage reduces to below 30 VAC or 60 VDC within one second after the connector is separated. NHTSA does not believe connectors of high voltage sources should be excluded. If connectors are high voltage sources and if they can be accessed, opened, or removed without the use of tools, regardless of whether they are located under the floor, they should be required to meet the same requirements for voltage markings and direct contact protection as electric protection barriers. Additionally, the agency notes that “vehicle floor” and “connector” are not defined in GTR No. 13. Therefore, NHTSA would not exclude connectors of high voltage sources.

Post-Crash Physical Barrier Protection Option

GTR No. 13 specifies that individual contracting parties of the 1998 agreement may elect to propose the physical barrier protection from direct and indirect contact of high voltage sources and live parts. According to GTR No. 13, for protection against direct contact, high voltage sources and live parts are required to have protection degree IPXXB. For protection against indirect contact, GTR No. 13 requires that the resistance between all exposed conductive parts and electrical chassis be lower than 0.1 ohm when there is current flow of at least 0.2 A.

The physical barrier protection option in this NPRM includes the same provisions for direct and indirect contact protection as that in GTR No. 13 but adds two additional requirements for indirect contact protection (from SAE J1766 January 2014).

This first additional requirement is that the resistance between any two simultaneously reachable exposed conductive parts of the electrical protection barriers that are less than 2.5 meters from each other is less than 0.2 ohms. This additional requirement protects against indirect contact of high voltage sources when two electrical protection barriers are contacted simultaneously. The second additional requirement is that the voltages between an electrical protection barrier enclosing a high voltage source and other exposed conductive parts are less than or equal to 30 VAC or 60 VDC. This additional requirement is included in SAE J1766 January 2014 to provide additional protection from indirect contact of high voltage sources, addressing the issues raised in the Battelle research of the physical barrier protection option.

Verification of Post-Crash Indirect Contact Protection

GTR No. 13 states that a high voltage source is considered to have post-crash indirect contact protection if the electrical protection barrier enclosing the high voltage source has a galvanic connection to the chassis by welding. This method of verification is a mere visual inspection and lacks the objectivity needed for an FMVSS. This NPRM does not include this method of verification and instead proposes to use the test procedure in GTR No. 13 whereby a current of 0.2 A is passed through the connection to determine its resistance.

Physical Barrier Protection of AC High Voltage Sources That Are Connected to DC High Voltage Sources

This NPRM proposes to adopt the physical barrier protection requirement for direct contact specified in GTR No. 13 for both post-crash and during normal vehicle operation. However, for indirect contact protection, the proposal uses the proposed post-crash indirect contact protection requirements described above (which include two additional requirements described above in addition to that specified in GTR No. 13).

Optional Procedures for Evaluating Electrical Isolation Post-Crash

FMVSS No. 305's test procedure for measuring electrical isolation of high voltage sources is similar to that in GTR No. 13. However, GTR No. 13 permits the crash tests to be conducted without energizing the electric power train while FMVSS No. 305 does not. In conditions where the high voltage sources are not energized during the crash test, GTR No. 13 permits measuring electrical isolation resistance of high voltage sources by other means, including using a megohmmeter.²⁹ Yet, GTR No. 13 does not specify a test procedure to measure isolation resistance using a megohmmeter.

NHTSA is not proposing to conduct the crash test without energizing the electric power train and so is not permitting the use of the megohmmeter. NHTSA stated its position on this matter in final rules published on June 14, 2010 (75 FR 33515), July 29, 2011 (76 FR 45436), and January 16, 2015 (80

²⁹ A megohmmeter is a specialized ohmmeter that is primarily used to determine electrical isolation resistance. This device operates by applying a voltage or current to the item being tested. Because externally applied voltages or currents can disrupt its measurement (and/or cause damage to the instrument) the megohmmeter is used to test items that are under an inactive and fully de-energized state.

FR 2320). In the January 16, 2015 final rule, NHTSA noted that the agency's research on the feasibility of using a megohmmeter for measuring electrical isolation presented certain technical questions that need to be resolved (*i.e.*, the research showed that megohmmeters could accurately measure electrical isolation resistance of DC high voltage sources in an inactive state but did not consistently do so for AC high voltage sources).

Additionally, electrical isolation resistance measurement with a megohmmeter is only possible when the electrical power train is not energized, such as when an inert gas is used in hydrogen containers of a fuel cell vehicle. NHTSA will address the issue of the use of inert gas in hydrogen containers of fuel cells vehicles when conducting crash tests in a future proposal to incorporate into FMVSSs the fuel system and fuel container integrity requirements of hydrogen fuel cell vehicles in GTR No. 13. The agency will address in that rulemaking the use of alternative methods of measuring isolation resistance in conditions where the electric power train is not energized in crash tests.

Procedures for Measuring Voltage Post-Crash

FMVSS No. 305 specifies that all post-crash voltage measurements for determining voltage and electrical isolation of high voltage sources with respect to the electric chassis be made after a minimum of 5 seconds after the vehicle comes to rest following impact. GTR No. 13 specifies that for determining post-crash electrical isolation of high voltage sources, the voltage measurements be made after a minimum of 5 seconds after “impact.” GTR No. 13 also specifies that for determining post-crash voltage (for assessing compliance with the low voltage option), the voltage measurements be made after a minimum of 5 seconds and no later than 60 seconds after impact.

The agency is not proposing to change the timing of voltage measurement post-crash in FMVSS No. 305 to harmonize with GTR No. 13. The “after impact” interval specified in GTR No. 13 appears less objective than FMVSS No. 305's measure and adopting the GTR No. 13 specified time for post-crash voltage measurement may reduce the objectivity of the test. Further, all-in-all we believe this difference in the timing of voltage measurement in FMVSS No. 305 and GTR No. 13 is minor.

Miscellaneous Differences Between the Proposed Regulatory Text and GTR No. 13

There is some unnecessary or redundant text in some sections of GTR No. 13 that we have not included in this proposal, to make the regulatory text more concise. An example of this is in the electrical isolation option for post-crash electrical safety, under conditions when the AC and DC high voltage sources are connected. GTR No. 13 specifies that the vehicle meet one of the following requirements: (1) Electrical isolation of the DC and AC high voltage sources from the chassis be no less than 500 ohm/volt; (2) electrical isolation of the DC and AC high voltage sources from the chassis be no less than 100 ohm/volt and the AC high voltage sources also have physical barrier protection; or (3) electrical isolation of the AC and DC high voltage sources from the chassis be no less than 100 ohm/volt and the AC high voltage source is considered as a low voltage source. We believe that the option (3) requirement above is unnecessary, because if the AC high voltage source is considered as a low voltage source, it already meets the low voltage electrical isolation option. Thus, we determined it is not necessary to provide option (3).

IV. Battelle Study and Developments

NHTSA initiated a research program in 2010, using Battelle as a contractor, to better understand the safety implications of using a physical barrier to protect against electric shock. The objectives of the research were to: (a) Determine failure modes associated with electrical protection barriers that could potentially result in electric shock to occupants in the vehicle or to rescue workers due to direct or indirect contact, (b) evaluate the practicability and feasibility of test procedures in what was then a draft version³⁰ of GTR

³⁰ The electrical safety requirements in the 2010 draft version of GTR No. 13 are the same as those in the GTR No. 13 that was established on June 27,

No. 13 for direct and indirect contact protection.

As discussed below (and in our supporting technical document)³¹ the Battelle research indicates that the physical barrier protection specified in GTR No. 13 would protect against electric shock when there is a single point failure in the electrical safety systems. However, if there were multiple failures in the electrical safety systems specified in GTR No. 13 for normal vehicle operating conditions,³² the Battelle research indicates that a person could receive an electric shock when they contact the high voltage sources in certain specific ways.

The Battelle study³³ identified various scenarios of electrical safety system failures, including direct contact of high voltage source, indirect contact of live parts of high voltage sources, loss in conductive connection between electrical protection barrier and chassis, and a combination of these failures. Direct contact of a high voltage source could occur in the event of a crash that results in mechanical failure of protection barriers or penetration of electrical insulation that would allow fingers or conductive tools to enter protection barriers and contact the high

2013. Henceforth, we refer to the draft version as the adopted GTR.

³¹ Along with this document, we have placed in the docket a supporting technical document providing further information on our analysis of the Battelle research and GTR No. 13.

³² Under GTR No. 13, during normal vehicle operation, all high voltage sources contained or connected to the power train are required to be electrically isolated from the chassis (with minimum electrical isolation of 500 ohms/VAC or 100 ohms/VDC) and enclosed by physical barriers that prevent direct human contact. The physical barriers enclosing these high voltage sources are required to be conductively connected to the chassis (with resistance less than 0.1 ohms) to provide indirect contact shock protection.

³³ Hydrogen Fuel Cell Vehicle—Electrical Protective Barrier Option, Final Report, DOT HS 812134, May 2015. Available at <http://www.nhtsa.gov/Research/Crashworthiness/Alternative%20Energy%20Vehicle%20Systems%20Safety%20Research> and in the docket for this NPRM.

voltage sources within the barrier. Indirect contact of high voltage sources could occur in the event of a crash in which an electrical protection barrier is energized due to loss in electrical isolation of the high voltage source within the barrier.

To illustrate failure modes associated with electric protection barriers, Battelle used the schematic shown in Figure 4 below in which a high voltage source (shown on the left side of the figure) is isolated from the vehicle chassis by resistances R_{iH} and R_{iL} on the positive and negative side, respectively, and enclosed in an electrical protection barrier (EPB₁). The high voltage source may be either DC or AC and may represent a variety of components such as a fuel cell, battery, motor, or capacitor.

Also shown in Figure 4 are electrical wirings from the positive side of the high voltage source to its negative side to complete the circuit. The schematic shows two electric protection barriers (EPB₂ and EPB₃) enclosing the wirings on the positive and negative side, respectively, and a body with resistance R_b contacting these two protection barriers. All three electrical protection barriers in the figure are conductively connected to the electrical chassis with resistances R_{Ch} , R_{ChH} , and R_{ChL} .

For normal vehicle operation, GTR No. 13 requires R_{iH} and R_{iL} resistances to provide electrical isolation of at least 500 ohms/VAC or 100 ohms/VDC. It also requires the electrical wiring to be insulated. Further, it requires the three electrical protection barriers (EPB₁, EPB₂, and EPB₃) to have protection degree IPXXD or IPXXB and be conductively connected to the chassis such that the resistances R_{Ch} , R_{ChH} , and R_{ChL} are less than 0.1 ohms. The lowest possible value of body resistance R_b is 500 ohms.³⁴

³⁴ IEC TC-60479-I, "Effects of current on human beings and livestock—Part I—General Aspects," 2005.

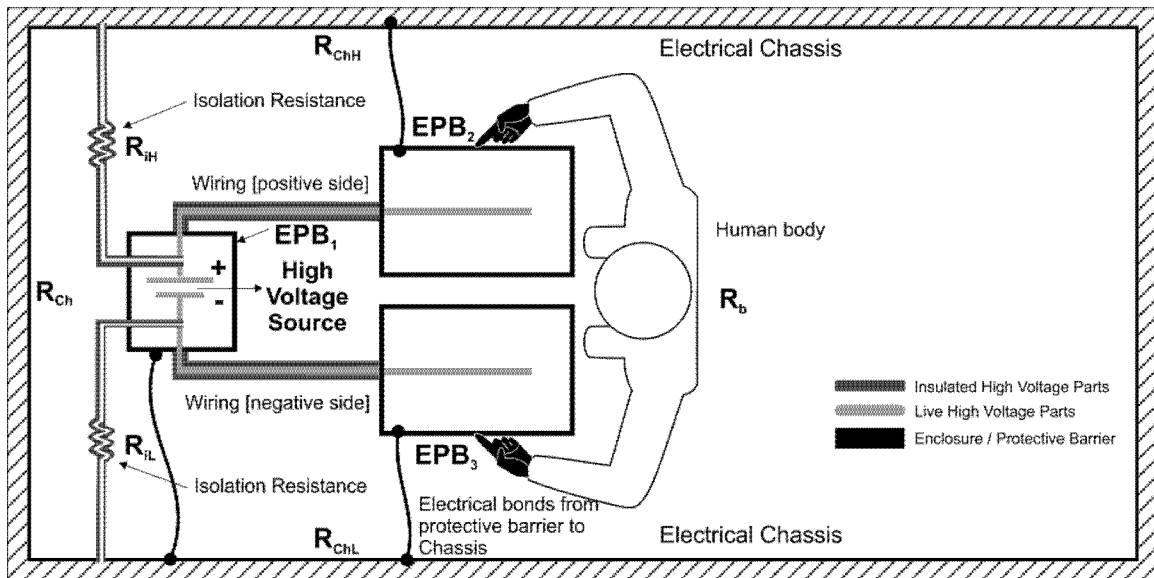

Figure 4. Schematic of body contact with electrical protection barriers

Battelle's analysis of the schematic in Figure 4 identified scenarios of direct contact and indirect contact of high voltage sources. Direct contact occurs when the electrical protection barriers EPB₂ and/or EPB₃ are breached or penetrated and the body contacts the wiring enclosed within. Indirect contact occurs when EPB₂ and/or EPB₃ are energized due to loss of electrical

isolation of the high voltage source within the barrier and the body contacts the electrical protection barriers as shown in Figure 4. Examples of direct and indirect contact scenarios are presented below:

- Case 1—Direct contact of high voltage source without electric shock hazard. Protection barrier EPB₂ is compromised and the body directly

contacts the electrical wiring from the positive side, and also contacts the electrical protection barrier EPB₃ enclosing the wiring on the negative side of the high voltage source (Figure 5). In this case, as long as the resistance R_{iL} or R_{iH} is greater than or equal to 500 ohms/VAC or 100 ohms/VDC, the current through the body (shown by dashed lines) will be within safe limits.

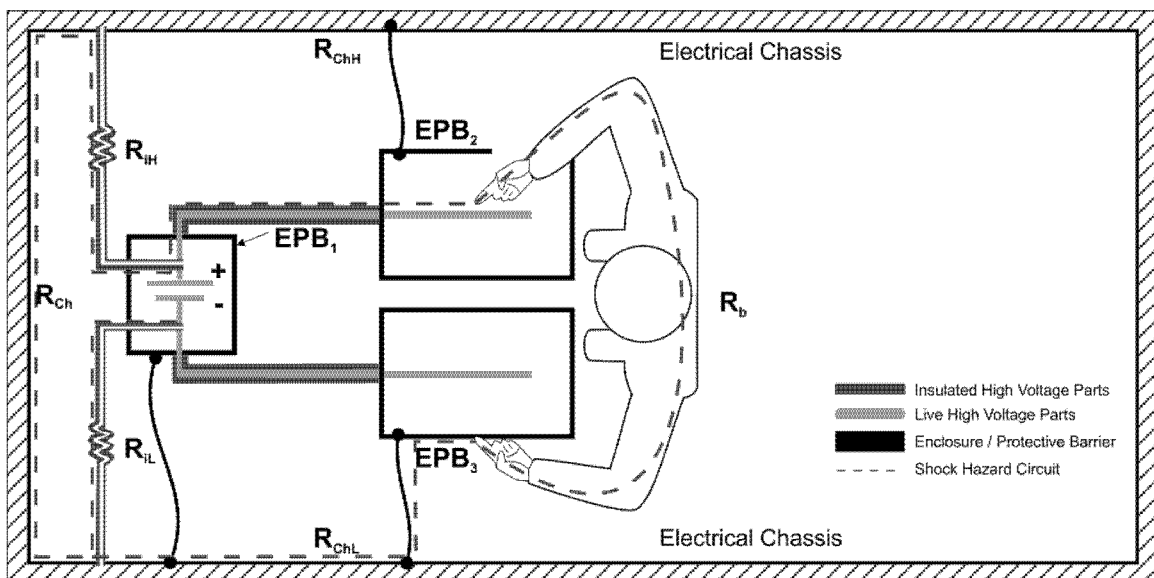

Figure 5. Case 1 - Direct contact of wiring on positive side of high voltage source and contact with electrical protection barrier (EPB₃) of the wiring on the negative side.

- Case 2—Direct contact of a high voltage source with electric shock hazard. Electrical protection barriers EPB₂ and EPB₃ of the wiring on the positive and negative side of the high

voltage source are compromised and the body contacts the positive and negative wiring (Figure 6). For the worst Case 2 condition, a body resistance R_b equal to 500 ohms (lowest possible) is used. For

a DC high voltage source of 350V, the minimum resistance value for R_{iL} and R_{iH} is 35,000 ohms. Since the body resistance R_b is significantly lower than the electrical isolation R_{iL} and R_{iH},

current through the body (shown by dashed lines) is not limited and the body would experience electric shock.

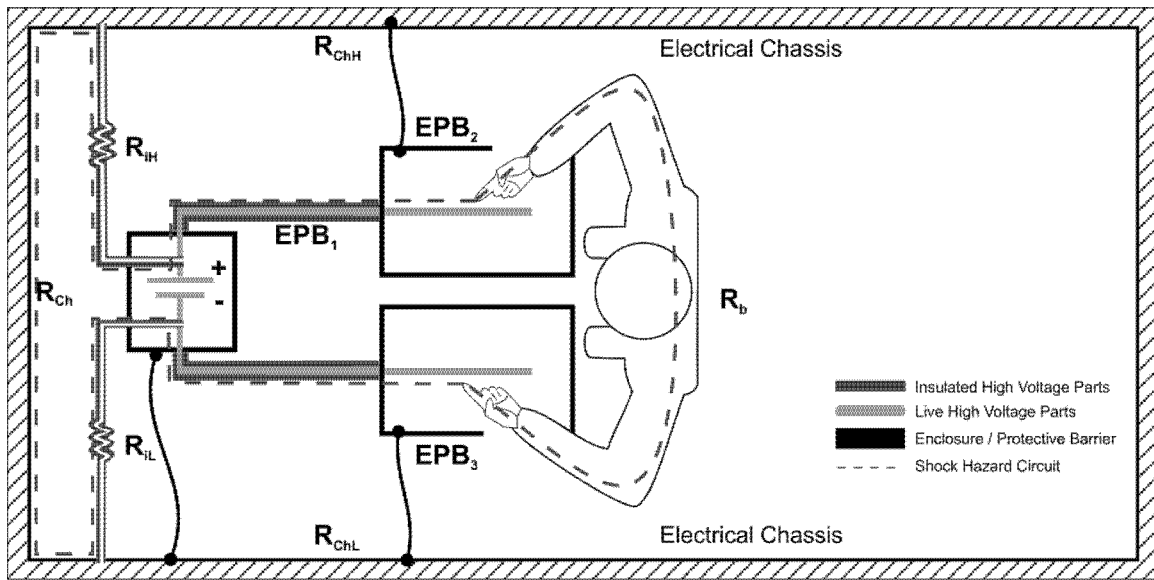

Figure 6. Case 2 - Direct contact of wiring on positive and negative side of high voltage source due to compromise (breaching or penetration) of electrical protection barriers EPB₂ and EPB₃.

• Case 3—Indirect contact of high voltage source without electric shock hazard. The wiring on the positive side of the high voltage source loses electrical isolation to the electrical

protection barrier, EPB₂, and the body contacts the electrical protection barriers EPB₂ and EPB₃ of the positive and negative wiring (Figure 7). Similar to Case 1, as long as the isolation

resistance R_{iL} or R_{iH} is greater than or equal to 500 ohms/VAC or 100 ohms/VDC, the current through the body (shown by dashed lines) will be within safe limits.

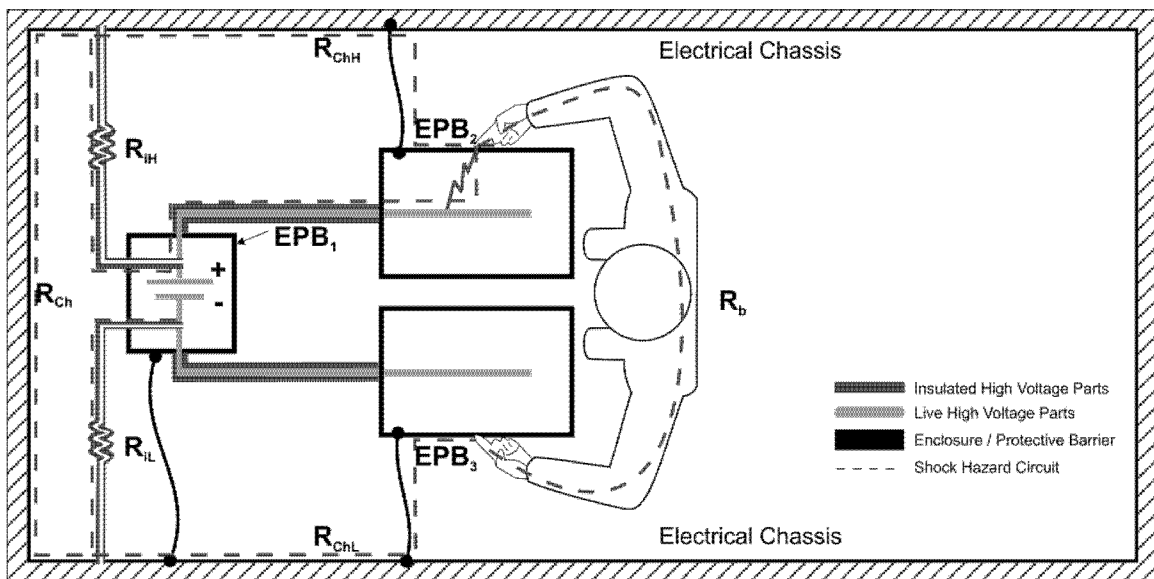

Figure 7. Case 3 - Wiring on positive side of the high voltage source loses electrical isolation to the protective barrier EPB₂ and the body contacts protective barriers EPB₂ and EPB₃.

• Case 4—Indirect contact of high voltage source with possibility of electric shock. The electric wiring of the positive and negative sides of the high voltage source lose electrical isolation to

the protective barriers EPB₂ and EPB₃, respectively, and the body contacts the two protective barriers EPB₂ and EPB₃ (Figure 8). Since R_{ch}, R_{chH} and R_{chL} are all very low values (less than 0.1 ohms

according to GTR No.13), this condition would result in a short circuit of the high voltage source that could activate and open a short circuit fuse that is generally equipped in electric

propulsion vehicles. If a fuse activates, then no current will flow and so no electrical shock would occur. However, if the fuse does not activate, and if the electrical isolation R_{iL} and R_{iH} are reduced to low levels and the chassis

resistance is not significantly low compared to the body resistance, then the current through the body contacting the protective barriers (shown by dashed line) may not be within safe limits and the body could experience

electric shock. This scenario is further discussed in the Alliance petition for rulemaking (*infra*) and in the supporting technical document of this NPRM.

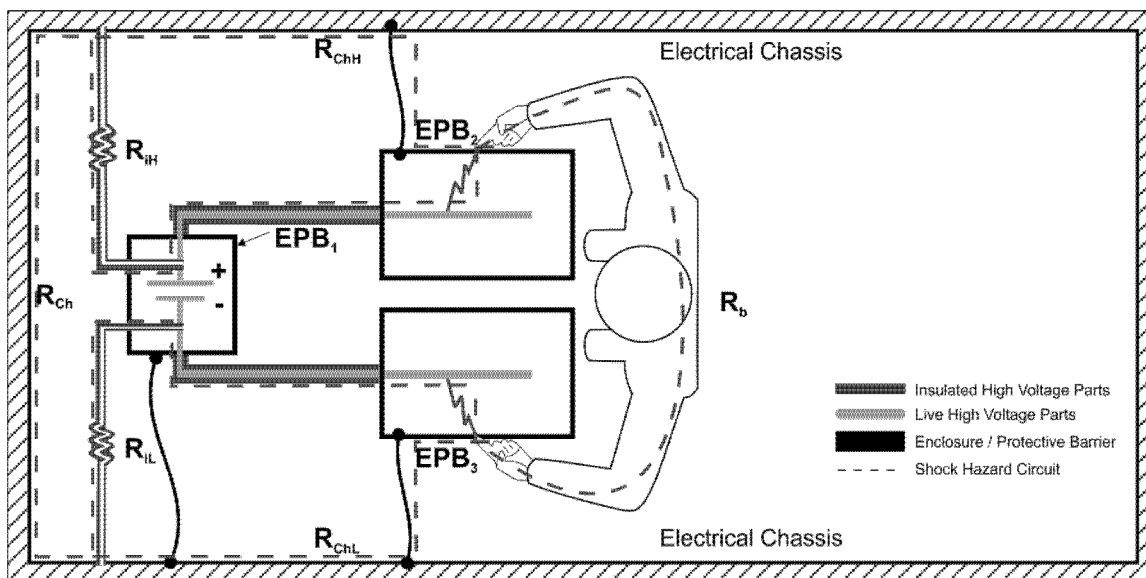

Figure 8. Case 4 - Wiring on positive and negative side of the high voltage source lose electrical isolation to the protective barriers EPB₂ and EPB₃, respectively, and the body contacts protective barriers EPB₂ and EPB₃.

Battelle identified additional scenarios, including those regarding loss in electrical isolation R_{iL} and/or R_{iH} and loss of electrical bonding of the protective barriers with the chassis.³⁵ These scenarios showed that, for vehicles that meet the electrical isolation and physical barrier protection requirement in GTR No. 13 during normal vehicle operation, electric shock is not possible when there is only a single point of failure in the electrical safety systems. However, electric shock is possible when at least two or three failures of electrical safety systems occur and a human body comes into contact with two compromised protective barriers on opposite sides of the high voltage source to complete the circuit. For example, in Case 2, electric shock could occur if two electrical protection barriers on the positive and negative side of the high voltage source are compromised and a body contacts the positive and negative side of a high voltage source by entering the two compromised protection barriers. In Case 4, electric shock could occur only if at least four electric safety features

(loss in electrical isolation of electrical protection barriers EPB₂ and EPB₃ which are on the positive and negative side of the high voltage source and loss in electrical isolation R_{iH} and R_{iL} of the high voltage source) are compromised and the body contacts both compromised barriers, EPB₂ and EPB₃.

To address the concern of electric shock from indirect contact, GTR No. 13 specifies that the physical barriers enclosing high voltage sources should be conductively connected with low resistance (less than 0.1 ohms) to the electrical chassis, so that if one segment of the high voltage source should lose electrical isolation, all contactable surfaces of the vehicle chassis and protective barriers will be at the same voltage and thereby prevent electric shock to a person touching two different protective barriers or parts of the electrical chassis.

Battelle also evaluated the maximum resistance (0.1 ohms) of the electric bonds between electrical protection barriers and the electrical chassis that is specified in GTR No. 13. Battelle found that in the event of multiple electrical safety system failures (loss in electrical isolation of both segments of the high voltage source to their electrical protection barriers) and a person

touching both the barriers to complete the circuit, the resistance of 0.1 ohms between the protective barrier and electrical chassis would not be sufficient to prevent electric shock to the person contacting the protective barriers.³⁶

V. Toyota Petition for Rulemaking

On December 23, 2013, Toyota submitted a petition for rulemaking to amend FMVSS No. 305 by adding an additional compliance option for electrical safety to allow HFCVs to be offered for sale in the US. Toyota notes that the requested compliance option includes elements of the electrical protection barrier that is currently in GTR No. 13. Toyota notes that many countries, including the European Union, Japan, and South Korea, already include electrical protection barrier as a compliance option for electrical safety in their standards.

Toyota explains its reasons for petitioning as follows.³⁷ FMVSS No. 305

³⁶ This issue is further explained in the supporting technical document in the docket of this NPRM.

³⁷ Honda Motor Co. Ltd. and American Honda Motor Co. Inc. (Honda) echoed these concerns in its comments on NHTSA's notice of receipt of Toyota's

³⁵ Details of these scenarios are presented in the Battelle final report, DOT HS 812 134, May 2015, which is available in the docket of this NPRM.

requires compliance with electrical safety requirements following impacts “at any speed up to and including” the specified test speeds. Toyota notes that for electric powered vehicles, including fuel cell vehicles, the DC high voltage sources (e.g. high voltage battery) will be connected to the AC high voltage sources (e.g. electric motor) during normal vehicle operation and in low speed crashes where the automatic disconnect does not operate.³⁸ In such conditions, when the AC and DC high voltage sources are connected, the isolation resistance at the AC high voltage source is in parallel with the isolation resistance of the DC high voltage source. Therefore, even if the electrical isolation provided for the AC high voltage source is significantly greater than the required 500 ohms/volt, the effective isolation resistance measured at the AC high voltage source can be, at most, as high as that provided for the DC high voltage source.

Toyota explains that in current battery electric vehicles, manufacturers are able to provide electrical isolation for the high voltage battery in excess of 500 ohms/volt, even though FMVSS No. 305 permits DC high voltage sources to have 100 ohms/volt with an electrical isolation monitoring system. On the other hand, it is difficult to maintain electrical isolation greater than 500 ohms/volt for the fuel cell stack in an HFCV due to the presence of fuel cell coolant.³⁹ Therefore, when the DC and AC high voltage sources are connected in an HFCV, it may not be possible to achieve the required 500 ohms/volt electrical isolation for AC high voltage sources.

Toyota states that NHTSA said in the June 14, 2010 final rule (75 FR 33515) that the agency was issuing the final rule to facilitate the development and introduction of fuel cell vehicles. One provision provided by the final rule was to specify lower minimum electrical isolation requirements for DC than AC high voltage sources (500 ohms/volt for AC and 100 ohms/volt for DC sources). Toyota further asserts that this flexibility offered for HFCVs is not useful unless a provision is made for the condition when the AC and DC high voltage sources are connected, such as

exemption petition, *supra*. See Docket No. NHTSA–2014–0068.

³⁸ Toyota noted that the automatic disconnect mechanism is not activated in low speed crashes, such as minor fender benders that may occur in a parking lot and in conditions where the inverters in the fuel cell auxiliary system may continue to operate.

³⁹ The fuel cell coolant may get ionized during repeated operation and may reduce the electrical isolation provided.

after a low speed crash.⁴⁰ Since such a provision is currently not available, HFCVs are essentially required to provide electrical isolation levels at or in excess of 500 ohms/volt at the fuel cell stacks.

Toyota asks that NHTSA adopt an alternative provision for electrical safety through isolation of high voltage sources that involves electrical protection barriers to address post-crash conditions where the AC and DC high voltage sources are connected. The petitioner suggests adopting GTR No. 13’s specification that the electrical isolation of the high voltage source may be greater or equal to 100 ohms/volt for an AC high voltage source if that AC source is conductively connected to a DC high voltage source, provided that the AC high voltage source meets the specified post-crash physical barrier protection requirements in GTR No. 13.⁴¹ The petitioner suggests specific regulatory text for the requirements and test procedures that are based on the specifications in GTR No. 13 for modifying FMVSS No. 305 to include the petitioner’s requested compliance option.

Toyota also requests that NHTSA amend S6.4 of FMVSS No 305 which requires vehicles to satisfy all of the post-crash performance requirements “after being rotated on its longitudinal axis to each successive increment of 90 degrees” to indicate that compliance with electrical isolation and physical barrier protection requirements would be evaluated after the vehicle is rotated a full 360 degrees. Toyota notes that the vehicle conditions related to the electrical isolation and physical barrier protection requirements do not change at various increments of a rollover and that it would be unreasonably dangerous for laboratory personnel to conduct the specified tests with the vehicle at 90 degree increments.

VI. Alliance Petition for Rulemaking

On November 10, 2014, the Alliance submitted a petition for rulemaking to update and upgrade FMVSS No. 305 to incorporate a physical barrier compliance option to provide protection

⁴⁰ FMVSS No. 305 requires that the electrical safety requirements in FMVSS No. 305 be met after front, rear, and side crash tests that include low speeds. In such conditions (which includes “fender benders”), the automatic disconnect is designed to remain closed so that the vehicle remains operational and so the driver can continue driving the vehicle.

⁴¹ The requirements for post-crash physical barrier protection option for electrical safety in GTR No. 13 are that after a crash test, high voltage sources have protection level IPXXB and that the resistance between all exposed conductive parts and the electrical chassis be lower than 0.1 ohm when there is a current flow of at least 0.2 amperes.

against electric shock. The Alliance states that the implementation of a physical barrier compliance option is especially critical to facilitate both the introduction of complying HFCVs as well as 48 volt mild hybrid technologies.⁴² The petitioner also believes the amendments would enable safe design innovation for all electrified vehicles, as well as reduce CO₂ emissions and increase fuel economy.

The Alliance states that the physical barrier compliance option is essential for FMVSS No. 305 certification of HFCVs in low speed crashes where the automatic disconnect is not designed to operate. The Alliance also states that in such crashes, the DC high voltage source can impinge on the AC high voltage sources through the inverter, making it impractical to achieve 500 ohms/volt electrical isolation for the AC high voltage source.

The Alliance explains that while it would seem that 48 volt mild hybrid systems would not be within the intended scope of FMVSS No. 305,⁴³ these systems typically convert DC voltage into three-phase AC voltage that can exceed the 30 VAC voltage threshold for consideration as a high voltage source in FMVSS No. 305.⁴⁴ The

⁴² 48 volt mild hybrid systems are generally internal combustion engines and a 48 volt battery equipped with an electric machine (one motor/generator in a parallel configuration) allowing the engine to be turned off whenever the car is coasting, braking, or stopped, yet restart quickly. These mild hybrids may employ regenerative braking and some level of power assist to the internal combustion engine, but do not have an exclusive electric-only mode of propulsion.

⁴³ FMVSS No. 305 considers electrical sources operating at voltages greater than or equal to 30 VAC or 60 VDC as high voltage sources that are subject to FMVSS No. 305 electrical safety requirements.

⁴⁴ We have also considered information provided by Mercedes-Benz in a briefing to the agency on June 2, 2015. As explained by Mercedes-Benz, the AC–DC inverter converts the DC current from the 48 V battery into AC for the 3-phase AC motor. Mercedes-Benz showed that the voltage between the electrical chassis and each of the phases of the AC electric motor is switched DC voltage (voltage between 0 and 48 volts). Since that voltage is less than 60 volts, it is considered low DC voltage under FMVSS No. 305. However, Mercedes-Benz noted that the voltage between two phases of the AC motor is AC, and may be slightly greater than 30 VAC under certain circumstances, which can be considered a high voltage AC source under the standard. Mercedes-Benz explained its view that physical barrier protection around the AC motor, and around cables from the inverter to the motor, would mitigate human contact with these AC high voltage sources, and thereby mitigate the likelihood of electric shock. Additionally, the presenter showed that electrical protection barriers enclosing the AC high voltage sources could be conductively connected to the chassis with resistance less than 0.1 ohms, and thereby provide electric shock protection from indirect contact of the high voltage sources. See the memorandum in the docket for this NPRM on Mercedes-Benz, Daimler AG, input on 48 V mild hybrid systems.

Alliance states that these 48 volt mild hybrid systems are grounded to the vehicle chassis and so cannot viably meet the existing isolation resistance option as well as the pretest measurement for isolation resistance. The Alliance notes that while it is feasible to design a 48 volt mild hybrid system that meets FMVSS No. 305 electrical isolation requirements, isolated systems inherently involve more complexity, higher consumer costs, and higher mass resulting in reduced fuel economy and increased emissions. The Alliance suggests that these results are particularly inappropriate since there is no incremental safety benefit provided by an isolated system compared to physical barriers. The Alliance states that as a result, it is requesting modifications to FMVSS No. 305 to permit the introduction 48 volt mild hybrid systems and HFCVs into the U.S.

The Alliance notes that in NHTSA's July 29, 2011, response to petitions for reconsideration of the 2010 final rule,⁴⁵ NHTSA deferred consideration of the physical barrier protection option pending additional research. The Alliance states that the agency's research on the physical barrier option⁴⁶ showed that electric shock from indirect contact in a crash could only be possible, if the following conditions were met (see Case 4 described above and illustrated in Figure 8):

- (1) A loss of electrical isolation within the enclosure of a high voltage source,
- (2) a loss of electrical isolation within a second (different) high voltage source enclosure,
- (3) these two distinct losses in isolation (specified in (1) and (2)) occur on opposite rails (positive and negative) of the high voltage source,
- (4) the overcurrent devices do not automatically open the circuit as a result of the simultaneous loss of isolation on the positive and negative rails to ground (the Alliance states that the normal design practice is for the overcurrent devices to automatically open under the circumstances outlined in (3)),
- (5) a person has access to these two enclosures in the crashed vehicle, and
- (6) a person touches these two enclosures simultaneously.

⁴⁵ 76 FR 45436.

⁴⁶ "Hydrogen Fuel Cell Vehicle—Electrical Protective Barrier Option," DOT HS 812134, May 2015, is available at <http://www.nhtsa.gov/Research/Crashworthiness/Alternative%20Energy%20Vehicle%20Systems%20Safety%20Research> and in the docket for this NPRM.

The Alliance believes that the likelihood of each of the above 6 events occurring is remote and that the simultaneous occurrence of these events in real world situations is even more remote and exceedingly small. The Alliance believes that the other scenarios identified in the Battelle final report as having potential safety concerns similarly require multiple failures in the system to occur, followed by what the petitioner believes to be unlikely human contacts and a lack of fuses or other electrical safety protection. Nevertheless, the Alliance states that, despite the extremely low likelihood of a safety issue from any of the scenarios in the final Battelle report, the updated version of SAE J1766 (January 2014)⁴⁷ includes performance requirements that safeguard against all safety critical scenarios identified in the Battelle report.

The Alliance expresses its support of the December 23, 2013 petition for rulemaking from Toyota to modify FMVSS No. 305 to facilitate the sale of HFCVs in the U.S. (petition discussed *infra*) and notes that the January 2014 version of SAE J1766 also includes provisions for a modified isolation requirement for AC systems with physical barriers, as Toyota requests in its petition for rulemaking. The Alliance states that SAE J1766 January 2014 also has provisions for a "stand-alone" physical barrier protection compliance option that is needed for facilitating the development of 48 volt mild hybrid systems, since electrical components of these systems are conductively connected to the chassis and so cannot viably satisfy electrical isolation requirements. The Alliance believes that this "stand-alone" physical barrier compliance option provides sufficient protection to address potential (although unlikely, states the petitioner) safety critical scenarios identified in the Battelle report.

The Alliance asserts that while FMVSS No. 305 only evaluates electrical safety in post-crash condition, auto manufacturers also design for high voltage safety under normal operating conditions. The petitioner states that providing physical barriers is the most common method of protection against high voltage contact in the automotive industry, as well as other industries that use high voltage electric circuits. The Alliance believes it is reasonable that this method of protection against electric shock hazard can also be used

⁴⁷ SAE J1766, "Recommended practice for electric, fuel cell, and hybrid electric vehicle crash integrity testing," January 2014, SAE International, <http://www.sae.org>.

for post-crash shock protection provided these physical barriers remain intact post-crash, and that either the voltage between exposed conductive parts is below 30 VAC or 60 VDC, or resistance between exposed conductive parts of the barriers and electrical chassis is below specified resistance levels.

The Alliance states it is urgent to update FMVSS No. 305 to facilitate the introduction of HFCVs and 48 volt mild hybrid technology vehicles that are necessary to accommodate compliance with Corporate Average Fuel Economy (CAFE) standards. Consequently, the petitioner states that it is not additionally requesting adoption of the low energy compliance option that is also included in SAE J1766 January 2014. Instead the petitioner requests that the low energy compliance option be considered for the electric vehicle safety (EVS) GTR that is currently in process.

SAE J1766 January 2014 also changes the time criterion for initiating verification of post-crash electrical safety from 5 seconds after the vehicle comes to rest (similar to the specification currently in FMVSS No. 305) to 10 seconds after initial impact. The Alliance states that given the urgency necessary to facilitate the introduction of HFCVs and 48 volt mild hybrid technology, it is limiting its petition for rulemaking to only include the post-crash physical barrier protection compliance option in SAE J1766 January 2014 into FMVSS No. 305.

Specifically, the Alliance requests including section 5.3.4 of SAE J1766 January 2014 into FMVSS No. 305. This section provides two options for post-crash electrical safety by means of physical barriers.

The first option (Option 1 for physical barrier protection) is similar to the post-crash physical barrier protection option for electrical safety in GTR No. 13,⁴⁸ but includes an additional requirement that the resistance between the high voltage source enclosed by the physical barrier and the exposed conductive parts of the electrical protection barrier be greater than 0.01 ohms/volt for DC high voltage sources and 0.05 ohms/volt for AC high voltage sources.

The second option for electrical safety through electrical protection barriers (Option 2 for physical barrier protection) in SAE J1766 January 2014

⁴⁸ Protection against direct contact with high voltage sources is provided by protection degree IPXXB and protection against indirect contact of high voltage sources is provided by requiring the resistance between exposed conductive parts and the electrical chassis to be lower than 0.1 ohm when there is a current flow of at least 0.2 amperes.

is through protection from direct contact by protection degree IPXXB, and that the voltage between the electrical protection barrier and other exposed conductive parts and the electrical chassis is less than or equal to 30 VAC for AC high voltage sources and 60 VDC for DC high voltage sources. The Alliance states that Option 2 is similar to the low voltage option already in FMVSS No. 305.

The Alliance supplemented its petition by a submission dated October

20, 2015, which provided an analysis of its proposal for electrical safety through physical barriers.⁴⁹ Figure 9, below, presents the circuit diagram the petitioner provided for the representation of a high voltage source (e.g., battery) with voltage of 1,000 VAC or 1,500 VDC, enclosed in physical barriers that are conductively connected to the electrical chassis with resistance less than or equal to 0.1 ohms. The circuit diagram also has a representation of a human body with a minimum

resistance of 500 ohms⁵⁰ contacting protective barriers enclosing opposite rails of the high voltage source. The resistances R_1 and R_2 in Figure 9 represent the resistance between the high voltage source and the protective physical barriers that enclose it. This circuit diagram is a representation of the indirect contact Battelle scenario, Case 4, in the event that electrical isolation of the high voltage source to the chassis is lost and R_{iH} and R_{iL} are equal to zero.

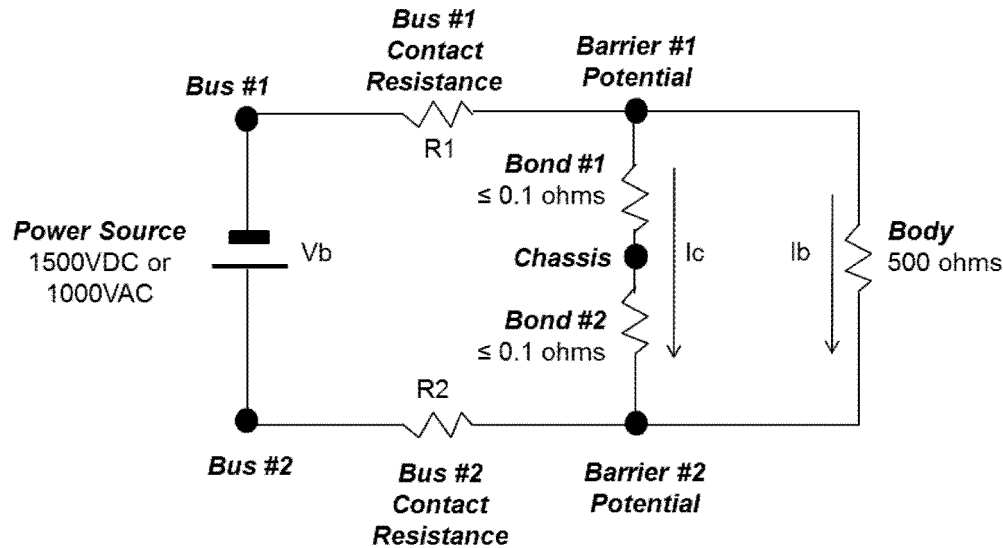

Figure 9. Circuit diagram representing a high voltage source enclosed by physical barriers that are conductively connected to the electrical chassis with resistance less than or equal to 0.1 ohms. R_1 and R_2 are the resistances between the high voltage source and the protective barriers. The circuit also has a representation of a human body touching the protective barriers of the opposite rails of the high voltage source.

According to Option 1 of the electrical protection barrier in the Alliance submission, the combined resistance⁵¹ of R_1 and R_2 is required to be less than or equal to 0.05 ohms/VAC or 0.01 ohms/VDC. Under Option 2, the voltage difference between barrier #1 and barrier #2 is required to be less than or equal to 30 VAC or 60 VDC. The Alliance observes that its analysis using the model in Figure 9 demonstrates that the proposed physical barrier protection option provides equivalent levels of safety as the electrical isolation option⁵² currently in FMVSS No. 305 in all the safety critical scenarios identified in the

Battelle study, including the scenario Case 4 for indirect contact.

The Alliance also states that the Option 1 electrical protection barrier is the same as that of Option 2 since the conditions that meet the Option 1 requirements also meet the Option 2 requirements. The Alliance acknowledges that it is difficult to measure the resistance between a high voltage source and the exposed conductive parts of the electrical protection barrier that encloses the high voltage source, as is needed to evaluate the Option 1 electrical protection barrier.⁵³ The Alliance recommends that NHTSA incorporate Option 2 (direct

contact protection degree IPXXB and voltage between electrical protection barrier and exposed conductive parts less than or equal to 30 VAC or 60 VDC) into FMVSS No. 305 since its analysis indicates that compliance with Option 1 would also entail compliance with Option 2.

The Alliance specifies the following test procedures from Appendix C in SAE J1766 January 2014: (1) Section C.1 for verifying IPXXB protection degree of physical barriers, which is similar to the procedure in GTR No. 13, (2) Section C.2.1 for verifying that the resistance between electrical protection barriers and electrical chassis is less than 0.1

⁴⁹The Alliance analysis of the physical barrier protection option proposed for electrical safety (October 2014) is in the docket of this NPRM.

⁵⁰According to IEC TC-60479-I, "Effects of current on human beings and livestock—Part I—General Aspects," 2005, the lowest possible electrical resistance of a human body is 500 ohms.

⁵¹ R_1 and R_2 resistances are in a parallel configuration.

⁵²The current through the body I_b (shown in Figure 9) is less than or equal to 10 mA of direct current or 2 mA of alternating current.

⁵³The resistance level is too low to measure accurately and in order to access a high voltage source enclosed in the physical barrier, some disassembly of the barrier may be required in some cases.

ohms, and (3) Section C.2.3 to verify that the voltage difference between any two exposed conductive parts of the electric chassis (including physical barriers) is less than or equal to 30 VAC or 60 VDC. The Alliance also specifies Section C.2.2 in SAE J1766 January 2014 for verifying that the resistance between a high voltage source and the electrical chassis⁵⁴ is greater than or equal to 0.05 ohms/VAC or 0.01 ohms/VDC. We note, however, that section C.2.2 does not provide a specific method of measurement and instead states, “The measurement may be performed by any means that provides sufficient accuracy for the post-crash situation.”

These test procedures are further discussed in a later section analyzing the petitions for rulemaking to modify FMVSS No. 305.

VII. Overview of Proposed Rule

NHTSA is initiating rulemaking to consider adopting GTR No. 13 into FMVSS No. 305, as appropriate under the Vehicle Safety Act, and to address the issues raised by the Alliance and Toyota in their respective petitions. We request comment on the decisions put forth in this NPRM, including those regarding minor additional provisions that the agency is considering to address the concerns of the petitioners.

NHTSA believes that this NPRM would improve the level of safety afforded to the public. Adopting the provisions from GTR No. 13 that reduce the risk of harmful electric shock during normal vehicle operation would improve FMVSS No. 305 by expanding its performance requirements beyond post-crash conditions. The proposed requirements would provide post-crash compliance options for new power train configurations that ensure that those configurations provide a comparable level of post-crash safety compared to existing electric vehicles.

The proposed amendments are summarized as follows. In furtherance of implementing GTR No. 13 and in response to the petitions for rulemaking—

a. This NPRM proposes to add electrical safety requirements for vehicle performance during normal vehicle operations (as opposed to during and after a crash), to mitigate electric shock due to loss in electrical isolation and direct or indirect contact of high voltage

sources. The electrical safety requirements during normal vehicle operations would include requirements for:

1. Direct Contact Protection From High Voltage Sources

i. IPXXD protection level for high voltage sources inside passenger and luggage compartments. IPXXB protection level for high voltage sources not in passenger and luggage compartments.

ii. IPXXB protection level for service disconnect that can be opened or removed without tools.

iii. Markings on barriers of high voltage sources that can be physically accessed, opened, or removed without the use of tools.

iv. Orange color outer covering for cables of high voltage sources that are located outside electrical protection barriers.

2. Indirect Contact Protection From High Voltage Sources

Exposed conductive parts of electrical protection barriers would have to be conductively connected to the chassis with a resistance less than 0.1 ohms, and the resistance between two simultaneously reachable exposed conductive parts of electrical protection barriers that are within 2.5 meters of each other would have to be less than 0.2 ohms.

3. Electrical Isolation of High Voltage Sources

i. 500 ohms/volt or higher electrical isolation for AC high voltage sources and 100 ohms/volt or higher for DC high voltage sources

ii. For conditions where AC and DC bus are connected, AC high voltage sources would be permitted to have electrical isolation of 100 ohms/volt or higher, provided they also have the direct and indirect contact protection described in 1 and 2, above.

iii. There would be an exclusion of 48 volt hybrid vehicles from electrical isolation requirements during normal vehicle operation.

4. Electrical Isolation Monitoring System for DC High Voltage Sources on Fuel Cell Vehicles

5. Electrical Safety During Charging Involving Connecting the Vehicle to an External Electric Power Supply

i. Minimum electrical isolation resistance of one million ohms of the coupling system for charging the electrical energy storage system; and

ii. Conductive connection of the electric chassis to earth ground before and during exterior voltage is applied.

6. Mitigating Driver Error by—

i. Requiring an indication to the driver when the vehicle is in active driving mode upon vehicle start up and when the driver is leaving the vehicle; and,

ii. Preventing vehicle movement by its own propulsion system when the vehicle charging system is connected to the external electric power supply.

b. This NPRM proposes to amend FMVSS No. 305's post-crash electrical safety requirements. The post-crash electrical safety requirements would include:

1. Adding an additional optional method of meeting post-crash electrical safety requirements through physical barrier protection from high voltage sources. The proposed specifications of this optional method of electric safety include requirements ensuring that:

i. High voltage sources would be enclosed in barriers that prevent direct human contact with high voltage sources (IPXXB protection level),

ii. Exposed conductive parts of electrical protection barriers would be conductively connected to the chassis with a resistance less than 0.1 ohms, and the resistance between two simultaneously reachable exposed conductive parts of electrical protection barriers that are less than 2.5 meters from each other would be less than 0.2 ohms, and

iii. Voltage between a barrier and other exposed conductive parts of the vehicle would be at a low voltage level that would not cause electric shock (less than 60 VDC or 30 VAC).

2. Permitting an AC high voltage source that is conductively connected to a DC high voltage source to meet lower minimum electrical isolation requirement of 100 ohms/volt provided the AC high voltage source also has physical barrier protection specified in 1, above.

VIII. Proposal Addressing Safety During Normal Vehicle Operations

We first discuss the proposed requirements for vehicle performance during normal vehicle operations, followed by those for performance post-crash.

a. Direct Contact Protection From High Voltage Sources

GTR No. 13 specifies safety measures to ensure that high voltage sources cannot be contacted. This safety measure is to enclose high voltage sources in physical barriers (electrical protection barriers) to prevent direct human contact. NHTSA is proposing to include in FMVSS No. 305 the direct contact protection requirements specified in GTR No. 13 for the passenger and luggage compartments and other areas.⁵⁵

NHTSA is proposing to assess protection against direct contact with high voltage sources contained inside the passenger and luggage compartments using a 1.0 mm diameter and 100 mm long test wire probe (IPXXD). This test probe ensures that any gaps in the protective barriers are

⁵⁴ Since the resistance between a protective physical barrier and the electrical chassis is required to be less than or equal to 0.1 ohm (a very low value), the resistance between a high voltage source and the physical barrier would be the same as or only slightly lower than the resistance between the high voltage source and the electrical chassis.

⁵⁵ GTR No. 13 assesses the potential for direct contact with high voltage components using test probes specified in ISO 20653.

no larger than 1 mm and that any live components contained within are no closer to the gap than 100 mm. This ensures that body parts, miscellaneous tools or other slender conductive items typically present in a passenger or luggage compartment cannot penetrate any gaps/seams in the protective enclosures and contact high voltage components contained within.

For assessing protection against direct contact with high voltage sources in areas other than the passenger and luggage compartments under normal operating conditions, NHTSA is proposing to use the test probe IPXXB, representing a test finger. In areas other than the passenger and luggage compartments, the barrier would not likely contact tools and other slender conductive items. Therefore, protection using the test wire probe IPXXD would not be necessary and the test finger probe IPXXB would be appropriate to prevent inadvertent contact with high voltage components contained in the protective enclosures, by persons such as mechanics.

GTR No 13 also requires that a service disconnect that can be opened, disassembled, or removed without tools requires IPXXB protection when it is opened, disassembled, or removed. NHTSA is proposing to include this requirement into FMVSS No. 305, as well as a definition for a service disconnect.

NHTSA is proposing marking (yellow high voltage symbol) for enclosures and barriers of high voltage sources that can be physically accessed, opened, or removed without the use of tools, similar to GTR No. 13. As explained earlier in this preamble, we are not excluding some barriers as GTR No. 13 does.

NHTSA is proposing that cables for high voltage sources which are not located within electrical protection barriers to be identified by an orange color outer covering, similar to GTR No. 13. However, as explained earlier in this preamble, we are not excluding some connectors as GTR No. 13 does.

As noted earlier in this preamble, GTR No. 13 specifies direct contact protection requirements for high voltage connectors separately, and has exclusions with which we do not agree. Per GTR No. 13, connectors do not need to meet IPXXB protection if they are located underneath the vehicle floor and are provided with a locking mechanism, or require the use of tools to separate the connector, or the voltage reduces to below 30 VAC or 60 VDC within one second after the connector is separated. For the reasons given earlier, NHTSA does not believe that the exclusions are

warranted and does not anticipate adopting them in a final rule.

b. Indirect Contact Protection From High Voltage Sources

Under GTR No. 13, exposed conductive parts (parts that can be contacted with the test probes, IPXXD or IPXXB, and become electrically energized under electrical isolation failure conditions) have to be protected against indirect contact during normal vehicle operation. GTR No. 13 requires electrical protection barriers or enclosures of high voltage sources to be conductively connected to the electrical chassis with resistance of no more than 0.1 ohms during normal vehicle operations. This requirement would provide protection from electric shock by shunting⁵⁶ any harmful electrical currents to the vehicle chassis should any electrically charged components lose isolation within the protective barrier.

For indirect contact protection, we propose to apply the same indirect contact protection requirements and test procedures as would apply under post-crash conditions (see discussion in next section, below). The proposed indirect contact protection requirements would be for exposed conductive parts of electrical protection barriers to be conductively connected to the chassis with a resistance less than 0.1 ohms and that the resistance between two simultaneously reachable exposed conductive parts of electrical protection barriers that are within 2.5 meters of each other be less than 0.2 ohms. These resistances would be measured by passing a current of at least 0.2 A between exposed conductive parts and the electrical chassis. For the reasons previously discussed, NHTSA is not including GTR No. 13's provision that permits visual inspection of welds as a method of assessing compliance of indirect contact protection.

c. Electrical Isolation of High Voltage Sources

This NPRM would require that under normal operating conditions, all high voltage sources of the power train and those connected to the power train have sufficient electrical isolation resistance

⁵⁶ Shunting is when a low-resistance connection between two points in an electric circuit forms an alternative path for a portion of the current. If a human body contacts an electrical protection barrier that is energized due to loss in electrical isolation of a high voltage source enclosed in the barrier, most of the current would flow through the chassis rather than through the human body because the current path through the chassis has significantly lower resistance (less than 0.1 ohm) than the resistance of the human body (greater or equal to 500 ohm).

measured against the electrical chassis to ensure that current flowing through a human body in contact with the vehicle is not dangerous.

For conditions where DC and AC high voltage sources are isolated from each other, DC high voltage sources would be required to have a minimum electrical isolation of 100 ohms/volt and AC high voltage sources would be required to have a minimum of 500 ohms/volt.

For conditions where DC and AC high voltage sources are connected, AC and DC high voltage sources would be permitted to have a minimum electrical isolation of 100 ohms/volt, provided the AC high voltage source has direct and indirect contact protection in a. and b. above.

We proposed to exclude 48 volt hybrid vehicles from these electrical isolation requirements during normal vehicle operation. Since electric components in 48 volt mild hybrid systems are conductively connected to the electric chassis, these systems would not be able to comply with electrical isolation requirements both during normal vehicle operations and after a crash. Therefore, we believe that the "normal use" requirements in GTR No. 13 need to be modified to permit the introduction of 48 volt mild hybrid systems.

The United Nations Economic Commission for Europe Regulation 100 (ECE R.100)⁵⁷ normal operation requirements were modified on June 10, 2014 to facilitate the development and sale of 48 volt mild hybrid systems. Under these changes, 48 volt mild hybrid systems that are conductively connected to the electrical chassis are exempt from the in-use electrical isolation requirements. However, electrical protection barriers are still required during normal vehicle operations for high voltage components of these 48 volt mild hybrid systems so as to provide direct and indirect contact protection. As discussed in a later section for post-crash electrical safety requirements, we believe that these 48 volt mild hybrid systems with electrical protection barriers for all high voltage components in the system would not pose concerns regarding electric shock. Therefore, NHTSA proposes to include a similar exclusion from in-use electrical isolation requirements for 48 volt mild hybrid systems that are conductively connected to the electrical chassis.

⁵⁷ Uniform Provisions Concerning the Approval of Vehicles with Regard to Specific Requirements for the Electric Power Train, ECE R.100-02, June 24, 2014.

d. Electrical Isolation Monitoring System for DC High Voltage Sources on Fuel Cell Vehicles

GTR No. 13 requires that DC high voltage sources (other than the coupling system for charging) in HFCVs have an on-board electrical isolation monitoring system, together with a warning to the driver if the isolation resistance drops below the minimum required value of 100 ohms/volt. Similarly, FMVSS No. 305 currently specifies that DC high voltage sources that comply with electrical safety requirements by the electrical isolation of 100 ohms/volt must have an electrical isolation monitoring system to warn the driver. Since most HFCVs would comply with the electrical isolation requirements in FMVSS No. 305 using the 100 ohms/volt option,⁵⁸ these HFCVs, which must have an electrical isolation monitoring system under GTR No. 13, would also be required by FMVSS No. 305 to have the monitoring system.

Nonetheless, to ensure that the intent of GTR No. 13 and FMVSS No. 305 are met, the agency is proposing to amend FMVSS No. 305 to indicate expressly that each DC high voltage source in fuel cell vehicles would need to be equipped with an electrical isolation monitoring system.

e. Protection From Electric Shock During Charging

GTR No. 13 requires electric vehicles whose rechargeable energy storage system are charged by conductively connecting to an external power supply to have a device to enable conductive connection of the electrical chassis to the earth ground during charging. Additionally, GTR No. 13 requires the isolation resistance between the high voltage source and the electrical chassis to be at least 1 million ohms when the charge coupler is disconnected. The first requirement ensures that in the event of electrical isolation loss during charging, a person contacting the vehicle does not form a ground loop with the chassis and sustain significant electric shock. The second requirement ensures that the magnitude of current through a human body when a person contacts a vehicle undergoing charging is low and in the safe zone. NHTSA believes these two normal use charging safety requirements are warranted and proposes to include them in FMVSS No. 305.

f. Mitigating Driver Error

Consistent with GTR No. 13, we propose amending FMVSS No. 305 to

⁵⁸ In fuel cell vehicles, the presence of fuel cell coolant may not permit electrical isolation levels of 500 ohms/volt of the DC source.

add requirements that mitigate the likelihood of driver error in operating electric vehicles. First, we propose requiring vehicles to provide an indication to the driver when the vehicle is in an active driving mode upon vehicle start up and when the driver is leaving the vehicle.⁵⁹ Second, we propose requiring vehicles to prevent vehicle movement by its own propulsion system when the vehicle charging system is connected to the external electric power supply.

IX. Proposal Addressing Safety Post-Crash

FMVSS No. 305 requires that after a crash, each high voltage source in the vehicle are either electrically isolated from the vehicle's chassis, or their voltage is reduced to levels considered safe from electric shock hazards (*i.e.*, less than 30 VAC or less than 60 VDC).

As noted in earlier sections, GTR No. 13 specifies that vehicles may meet regulatory requirements by having no high voltage levels (see (a) below), meet physical barrier protection requirements (see (b)) below, or meet electrical isolation requirements (see (c) below):

a. Voltage levels: The voltages of the high voltage source must be less than or equal to 30 VAC or 60 VDC within 60 seconds after the impact. (This option for electrical safety is currently in FMVSS No. 305.)

b. Electrical protection barrier: The physical protection requirement is an option each contracting party of the 1998 agreement may elect to adopt. The provision is similar to the electrical safety requirements during normal operations except that the protection degree IPXXB applies rather than IPXXD. (The provision for electrical protection through physical barriers is currently not in FMVSS No. 305.)

i. Protection from direct contact: Protection from direct contact of high voltage sources with protection degree IPXXB required.

ii. Protection from indirect contact: The resistance between all exposed conductive parts and electrical chassis is required to be less than 0.1 ohms when there is a current flow of at least 0.2 A.⁶⁰

c. Electrical isolation:

i. If the AC and DC high voltage sources are conductively isolated from each other, then the minimum electrical isolation of a high voltage source to the chassis is 500 ohms/volt for AC components and 100 ohms/

volt for DC components of the working voltage.

ii. If AC and DC high voltage sources are conductively connected, the minimum electrical isolation of AC and DC high voltage sources must be—

- 500 ohms/volt of the working voltage, or
- 100 ohms/volt of the working voltage with the AC high voltage sources meeting the physical protection requirements in (b) or have no high voltage as specified in (a).

(FMVSS No. 305 does not distinguish AC and DC high voltage sources that are conductively connected from those that are isolated. Thus, the method above for complying with electrical isolation requirements when AC and DC high voltage sources are connected post-crash (see c. ii. above) is not now available in FMVSS No. 305.)

Proposal

This NPRM proposes to amend the isolation resistance compliance option in FMVSS No. 305 to harmonize with GTR No. 13. We are proposing to add an optional method of meeting post-crash electrical isolation requirements for an AC high voltage source that is connected to a DC high voltage source. In such condition, the required minimum electrical isolation for the AC high voltage source is 100 ohms/volt provided the AC high voltage source meets the post-crash physical barrier protection requirements.

We are also proposing to add a physical barrier protection option for post-crash electrical safety that includes requirements specifying that:

i. High voltage sources must be enclosed in barriers that prevent direct human contact with high voltage sources (IPXXB protection level),

ii. Electrical protection barriers must be conductively connected to the chassis with a resistance less than 0.1 ohms, and the resistance between two simultaneously reachable exposed conductive parts of electrical protection barriers that are less than 2.5 meters of each other must be less than 0.2 ohms, and

iii. Voltage between a barrier and other exposed conductive parts of the vehicle must be at a low voltage level that would not cause electric shock (less than 60 VDC or 30 VAC).

Electrical Isolation Resistance Option

Currently, FMVSS No. 305's electrical isolation option requires that vehicles with high voltage sources meet different isolation requirements based on whether the vehicle is an AC or a DC high voltage source. Electric powered vehicles are required to electrically isolate AC and DC high voltage sources from the chassis with electrical isolation no less than 500 ohms/volt, but the DC high voltage source can have electrical isolation no less than 100 ohms/volt if

⁵⁹ We note that an NPRM issued on FMVSS No. 114, "Theft protection and rollaway prevention" (76 FR 77183) proposes to require vehicles with keyless ignition controls to provide an audible warning to the driver exiting the vehicle while the propulsion system is operating. We request comment on whether the FMVSS No. 114 requirement, if adopted, would satisfy this provision in the GTR.

⁶⁰ GTR No. 13 considers this requirement to be met if visual inspection indicates that conductive connection has been established by welding. The minimum resistance requirement is only evaluated in case of doubt.

the DC high voltage source has an electrical isolation monitoring system.

GTR No. 13 differs from FMVSS No. 305 by distinguishing between situations where AC and DC high voltage are conductively isolated from each other or are conductively connected. GTR No. 13 states that when AC and DC high voltage sources are isolated from each other, the AC high voltage sources need to maintain electrical isolation no less than 500 ohms/volt and DC sources need to maintain electrical isolation no less than 100 ohms/volt. This is similar to FMVSS No. 305.⁶¹

When the AC and DC sources are conductively connected, GTR No. 13 affords three different methods for these high voltage sources to achieve compliance:

(1) All AC and DC sources maintain minimum electrical isolation of 500 ohms/volt (this is basically the approach of FMVSS No. 305);

(2) AC high voltage sources that are linked to a DC high voltage source may have a minimum of 100 ohms/volt instead of 500 ohms/volt if the AC high voltage source also has physical barrier protection from direct and indirect contact of high voltage sources;⁶² or

(3) all AC and DC sources maintain a minimum isolation resistance of 100 ohms/volt and all AC sources meet low-voltage requirements in GTR No. 13.

Need for Amendment

After reviewing the Toyota petition and other information, NHTSA understands petitioners' concern about FMVSS No. 305's electrical isolation requirements for AC high voltage sources under the conditions when the AC and DC bus are conductively connected. We tentatively believe that an amendment is warranted to facilitate

⁶¹ We note that GTR No. 13 permits DC high voltage sources to have 100 ohms/volt minimum electrical isolation without specifying that the DC high voltage sources must be equipped with an electrical isolation monitoring system. While this appears to differ from FMVSS No. 305, we do not believe there is a practical difference. The only vehicles needing to use FMVSS No. 305's 100 ohms/volt electrical isolation compliance option for DC high voltage sources are fuel cell vehicles. In this NPRM, the agency is proposing to require all DC high voltage sources of fuel cell vehicles to be equipped with an electrical isolation monitoring system. Therefore, while we propose to adopt the post-crash electrical isolation requirements for DC high voltage sources in GTR No. 13 into FMVSS No. 305 to further harmonization efforts, we do not believe there would be an effect on vehicle design or safety.

⁶² FMVSS No. 305 does not distinguish when the AC and DC sources are connected from when AC and DC sources are separated. The standard specifies that all AC high voltage sources must have a minimum electrical isolation of 500 ohms/volt. The condition involving connected AC and DC high voltage sources is germane to the Toyota petition.

the manufacture of fuel cell and other vehicles.

If FMVSS No. 305 were not amended, the electrical isolation for fuel cell stacks would need to be 500 ohms/volt or greater to comply with FMVSS No. 305, which may not be technically feasible.

Proposal for Electrical Isolation Option

In consideration of the above, NHTSA is proposing to add an option that would permit an AC high voltage source that is connected to a DC high voltage source post-crash to have electrical isolation no less than 100 ohms/volt provided the high voltage source also meets physical barrier protection requirements. Specifically, the electrical isolation option for electrical safety in the proposal requires that the electrical isolation of a high voltage source be greater than or equal to one of the following:

(1) 500 ohms/volt for an AC high voltage source; or

(2) 100 ohms/volt for an AC high voltage source if it is conductively connected to a DC high voltage source, but only if the AC high voltage source meets the physical barrier protection requirements; or

(3) 100 ohms/volt for a DC high voltage source.

NHTSA tentatively believes that adding this option into the existing FMVSS No. 305 requirements essentially harmonizes with the electrical isolation option in GTR No. 13. When an AC and DC high voltage source are conductively connected, the electrical isolation measured will be the same for both high voltage sources and approximately equal to the lower electrical isolation measurement of the two. Accordingly, the combined electrical isolation of conductively connected AC and DC high voltage sources can be greater than or equal to 500 ohm/volt only if the electrical isolation of each AC and DC high voltage sources are greater than or equal to 500 ohms/volt. Therefore the first option for electrical isolation in GTR No. 13 when an AC and DC high voltage source are conductively connected is redundant to what is already in FMVSS No. 305 since it is equivalent to the electrical isolation requirement when the AC and DC high voltage sources are conductively isolated from each other. The third option for electrical isolation in GTR No. 13 is unnecessary because if an AC high voltage source meets low voltage requirements, there is no need to meet the electrical isolation requirements.

We note, however, that the physical barrier protection requirement in the

proposed regulatory language to accommodate a lower electrical isolation level for a AC high voltage source that is conductively connected to a DC high voltage source is not the same as that specified in GTR No. 13. The physical barrier protection requirement is an option each contracting party of the 1998 agreement may elect to adopt. As explained in the following section, although our proposal in this document chooses not to adopt the physical barrier option in GTR No. 13 per se, we are proposing to adopt a modified physical barrier option. Based on the information from the Battelle research, the Alliance petition, the Toyota petition and other sources, we tentatively believe that our proposed physical barrier option will afford the compliance flexibility that the manufacturers desire while providing a level of safety that is more comparable to the other post-crash electric shock compliance options.

Physical Barrier Protection

Need for Amendment

The Alliance petition for rulemaking requested updates to FMVSS No. 305 for facilitating the development and sale of not only HFCVs but also 48 volt mild hybrid vehicles. Because 48 volt batteries are considered low voltage, the 48 volt mild hybrid systems are designed with conductive connection to the electric chassis and so are unable to provide electrical isolation. While most parts of the 48 volt mild hybrid system would be considered low voltage per the measurement to the chassis, the voltage between different phases of the 3-phase AC motor can be slightly greater than 30 VAC and so would be considered a high voltage source.

The Alliance Petition

The agency has considered the information provided by the Alliance and by Mercedes-Benz⁶³ and tentatively concludes that without an electrical protection barrier option, 48 volt mild hybrids will not be a practical consideration for improving fuel economy. In the absence of such an option, these systems will need to be electrically isolated from the chassis and thereby result in higher mass, reduced fuel economy, increased emissions, and higher consumer costs.

Regarding the Battelle study, we first begin by noting that we agree with the Alliance's analysis that for electric

⁶³ We discussed the Mercedes-Benz information earlier in this preamble, in the section describing the Alliance's petition for rulemaking, *supra*. 48 V Systems—Powerful Innovative Technologies for 2020 FC Targets, Mercedes-Benz, Daimler AG, June 2, 2015. Available in the docket for this NPRM.

powered vehicles that meet the electrical isolation and physical barrier protection requirement in GTR No. 13 during normal vehicle operation, there is a very low likelihood that the various safety critical scenarios identified in the Battelle report with electric shock potential would occur. The scenarios would only be possible if multiple failures of safety systems occurred, along with human contact to very specific locations. Be that as it may, the Alliance petition also suggested modifications to the electrical protection barrier provisions in GTR No. 13, which it states provide the same level of protection as the electrical isolation option for electrical safety in FMVSS No. 305 along with protection from the safety critical scenarios identified in the Battelle report.

The physical barrier protection option in the Alliance petition specifies two optional methods of providing physical barrier protection from direct and indirect contact of high voltage sources. The first method (Option 1) requires an AC or DC high voltage source to have:

1. Direct contact protection degree IPXXB,
2. All exposed conductive parts of electrical protection barriers are conductively connected to electrical chassis with resistance less than 0.1 ohms, and
3. The electrical isolation between the high voltage source and the electrical protection barrier enclosing it is greater than or equal to 0.05 ohms/VAC or 0.01 ohms/VDC.

The second method (Option 2) requires an AC or DC high voltage source to have:

1. Direct contact protection degree IPXXB.
2. The voltage between the electrical protection barrier and other exposed conductive parts is low voltage (30 VAC or 60 VDC).

Technical Analysis

The physical barrier protection provides electrical safety via electrical protection barriers that are placed around high voltage components to insure that there is no direct or indirect human contact with live high voltage sources during normal vehicle operation or after a vehicle crash. For protection against contact with live parts in post-crash conditions, a test probe designed to simulate a small human finger (12 mm) conforming to ISO 20653 "Road vehicles—Degrees of protection (IP-Code)—Protection of electrical equipment against foreign objects, water, and access (IPXXB)" is specified

in GTR No. 13.⁶⁴ The agency notes that protection against direct contact of high voltage sources is currently not specified in FMVSS No. 305 and so adding such a provision into FMVSS No. 305 would further enhance protection from electric shock. The IPXXB finger probe is utilized in other standards⁶⁵ for protecting electrical maintenance personnel from inadvertently contacting high voltage during servicing of electrical equipment. Therefore, NHTSA tentatively believes protection level using the simulated human finger probe (IPXXB) to prohibit inadvertent contact by passengers and first responders with high voltage components contained within protective enclosures is appropriate.⁶⁶

NHTSA reviewed⁶⁷ the Alliance's proposal for a post-crash electrical protection barrier option for FMVSS No. 305 and confirmed that the electric current I_b through the body (with minimum resistance of 500 ohms) in Figure 9, *supra*, is less than or equal to 10 mA DC or less than or equal to 2 mA AC under various scenarios, as long as the three requirements for the Alliance-suggested Option 1 for post-crash physical barrier protection are met. These are: 1. Direct contact protection degree IPXXB, 2. all exposed conductive parts are conductively connected to electrical chassis with resistance less than 0.1 ohms, and 3. the combined resistance of R_1 and R_2 and the resistance of the conductive connection of the electrical protection barrier to the chassis is greater than or equal to 0.05 ohms/VAC or 0.01 ohms/VDC. When all three conditions in the Option 1 physical barrier protection suggested by Alliance are met, the agency's analysis showed that in the event of loss in electrical isolation, the body current is limited to safe levels under the various safety critical scenarios identified in the Battelle study. The agency's analysis

⁶⁴ IEC60529 Second edition 1989–11 + Am. 1 1999–11, EN60529, "Degrees of protection provided by enclosures."

⁶⁵ For example, IEC 60479, "Low voltage switchgear and control gear assemblies," uses IPXXB level protection for preventing contact with high voltage sources by maintenance personnel. The voltage levels considered in IEC 60479 are similar to those in automotive application.

⁶⁶ The use of the IPXXB finger probe as opposed to the IPXXD wire probe for evaluating direct contact protection after a crash test is appropriate. The IPXXD is intended to evaluate contact with high voltage sources inside the passenger or luggage compartment during normal vehicle operation to ensure that body parts, miscellaneous tools or other slender conductive items typically encountered in a passenger or luggage compartment cannot penetrate any gaps/seams in the protective enclosures and contact high voltage components contained within.

⁶⁷ Supporting technical document in the docket of this NPRM.

also confirmed that when the above conditions are met, the voltage between barrier #1 and barrier #2 in Figure 9 is less than or equal to 30 VAC or 60 VDC, as the Alliance noted.⁶⁸

The specification that the conductive connection between a protection barrier and the chassis be less than 0.1 ohm provides protection from electric shock by shunting any harmful electrical currents through the vehicle chassis (rather than through a human contacting the protection barrier) should any electrically charged components lose isolation within the protective barrier. The 0.1 ohms resistance level for electrical bonding (or conductive connection) is well established in international standards both in and out of the automotive industry (e.g. MIL_B_5087, NASA Technical Standard NSA-STD-P023 "Electrical Bonding for NASA Launch Vehicles, Payloads, and Flight Equipment," ISO6469, ECE-R100, and IEC 60335-1 "Household and Similar Electrical Appliances" Part 1: General Requirements). For these reasons, NHTSA accepts that the resistance of the conductive connection between the protective barrier and the electrical chassis be less than 0.1 ohms.

However, the agency sought clarification on the indirect contact protection requirement of Option 1 suggested by the Alliance, which states that, "The resistance between exposed conductive parts of the electrical protection barrier(s) and the electrically conductive chassis is less than 0.1 ohms where there is a current flow of at least 0.2 A." NHTSA noted that the maximum allowable resistance for the electrical chassis was not specified and asked the Alliance how its suggested Option 1 would afford adequate indirect contact protection when exposed conductive parts of two electrical protection barriers were contacted simultaneously instead of simultaneous contact of an electrical protection barrier and the chassis.

⁶⁸ For example, an analysis of the circuit in Figure 9 was conducted using the following values for the components in the circuit: $V_b = 1000$ VDC, bonding resistance bond #1 and bond #2 equal to 0.1 ohm, R_1 and R_2 resistances equal to 20 ohms, and body resistance equal to 500 ohms. This resulted in a combined resistance of R_1 and R_2 and bonding resistance to chassis of 10.05 ohms (or 0.01005 ohms/volt electrical isolation from the chassis) and current through the body of 9.95 mA (<10 mA considered as safe level of current). The analysis also showed that in this example, the voltage between barrier #1 and barrier #2 is equal to 4.97 volt (<60 volt is considered to be low voltage). This is further explained in the supporting technical document in the docket of this NPRM.

In response,⁶⁹ the Alliance acknowledged that the effective resistance between two exposed conductive parts of the electrical protection barriers was not well defined in its proposal. The petitioner stated that in order to address the fact that there are no resistance specifications for the electrically conductive chassis, it recommends the addition of a performance requirement that limits the maximum resistance between any two exposed conductive parts of the electrical protection barriers to less than 0.2 ohms (which corresponds to the requirement that maximum resistance between the protective physical barrier and the electrical chassis is less than 0.1 ohms). The Alliance also stated that the resistance measurements between any two exposed conductive parts of the electrical protection barriers should be limited to those that can be simultaneously contacted by a human. The petitioner stated its belief that limiting the resistance measurement to a distance of 2.5 meter⁷⁰ would ensure that any surfaces that can be simultaneously contacted by a human be subjected to the proposed performance requirements. The petitioner noted that such a distance limitation would significantly reduce the test burden (number of test points) while maintaining the same level of safety. Accordingly, the Alliance offered the following modification to the text in SAE J1766 regarding indirect contact protection requirements and requested that NHTSA seek comment on it in an NPRM.

[Petitioner's suggested requirement] S5.3.4(2)—The bonding resistance between any exposed conductive parts of the electrical protection barriers and the vehicle's electrical chassis shall not exceed 0.1 ohms. This requirement is deemed satisfied if the galvanic connection has been made by welding and the weld is intact after each of the specified crash tests. In addition, the bonding resistance between any two simultaneously reachable exposed conductive parts of the electrical protection barriers in a distance of 2.5 meters shall not exceed 0.2 ohms. See C.2.1 for the applicable test procedure.

The agency tentatively concludes that this modification responds to NHTSA's concern about the lack of resistance specification for the electrical chassis and the lack of low resistance

⁶⁹ Alliance's response to NHTSA's questions is in the docket of this NPRM.

⁷⁰ This distance specification was obtained from IEC 60364-4-41. "Low-voltage electrical installations—Part 4-4—Protection against electric shock." Annex B (Obstacles and Placing out of Reach), and ISO6469-3.:2011, "Electrically propelled road vehicles—Safety specifications—Part 3: Protection of persons against electric shock."

specification between two electrical protection barriers that can be contacted simultaneously.⁷¹ However, we note that the requirement in the suggested S5.3.4(2) above is for the resistance to be less than or equal to 0.1 ohms and 0.2 ohms, while SAE J1766 January 2014 and GTR No. 13 specify that the resistance be less than 0.1 ohms. For purposes of harmonization with GTR No. 13, the agency proposes to use "less than 0.1 ohms" and "less than 0.2 ohms."

The proposed modification suggested by the Alliance also states, "This requirement is deemed satisfied if the galvanic connection has been made by welding and the weld is intact after each of the specified crash tests." We believe that such a method of assessing compliance of indirect contact protection by visually inspecting the welding lacks objectivity that is needed for FMVSS. Therefore, NHTSA proposes not including this method for evaluating compliance. Instead, the agency proposes to include the test procedure in GTR No. 13 and SAE J1766 January 2014 that determines the resistance between an electrical protection barrier and the chassis and between two electrical protection barriers by passing through a current of at least 0.2 A. NHTSA seeks comment on its proposal not to include assessing compliance of a conductive connection by means of visual inspection.

The agency's review had also indicated that the Alliance's proposed Option 2 for physical barrier protection (direct contact protection degree IPXXB and the voltage between barrier #1 and barrier #2 is less than or equal to 30 VAC or 60 VDC) does not guarantee that the current through the body is less than 10 mA DC and 2 mA AC for all scenarios.⁷² NHTSA requested that the Alliance provide clarification on this

⁷¹ NHTSA's analysis using 0.2 ohm resistance (instead of 0.1 ohm) between two protective barriers along with IPXXB protection and isolation between high voltage source and the protective barrier of 0.01 ohm/VDC or 0.05 ohm/VAC results in safe current levels through the body (10 mA DC or 2 mA AC). See details of NHTSA's analysis in the supporting technical document in the docket of this NPRM.

⁷² For example, an analysis of the circuit in Figure 9 was conducted using the following values for the components in the circuit: $V_b = 1000$ VDC, bonding resistance bond #1 and bond #2 equal to 0.1 ohm, R1 and R2 resistances equal to 1.6 ohms, and body resistance equal to 500 ohms. This resulted in a combined resistance of R1 and R2 and bonding resistance to chassis of 0.85 ohms (or 0.00085 ohms/volt electrical isolation from chassis) and current through the body of 117 mA (>10 mA is considered an unsafe level of current). The analysis also showed that in this example, the voltage between barrier #1 and barrier #2 is equal to 58.52 volt (<60 volt is considered to be low voltage). This is further explained in the supporting technical document in the docket of this NPRM.

matter. The Alliance responded⁷³ that FMVSS No. 305 already recognizes these low voltage thresholds, both with respect to the applicability of the standard and with respect to the electrical safety provisions of the standard. The Alliance also noted that GTR No. 13 and numerous other government regulations and industry standards recognize these low voltage threshold levels for automotive applications.⁷⁴ The Alliance observed that for voltage below or equal to 30 VAC and 60 VDC, the potential body current is below the let-go limit⁷⁵ and below the limit for electric shock with non-reversible harm. The Alliance stated that it is for these reasons that voltage levels below 30 VAC and 60 VDC are designated worldwide as low voltage without safety concern.⁷⁶

NHTSA tentatively agrees with the clarification provided by the Alliance that voltage levels at or lower than 30 VAC and 60 VDC are already specified as low voltage in FMVSS No. 305 and at these voltage levels, the potential body current is below the limit for electric shock. Currently, the European Union, Japan, and Korea, permit compliance for electrical safety using the electrical protection barrier option in GTR No. 13 and NHTSA is not aware of any incidence of electrical shock during normal operation and after a crash.

The Alliance suggested adopting Option 2 for physical barrier protection rather than Option 1 because it is difficult to measure electrical isolation between the high voltage source and exposed conductive parts of its electrical protection barrier, which is needed to assess compliance with Option 1.⁷⁷ Additionally, the agency's analysis confirms that of the Alliance's, that if the three conditions of Option 1 are met, the two conditions of Option 2 would also be met and in the event of loss of electrical isolation, the current through a body contacting electrical protection barriers is within safe levels

⁷³ Alliance's response to NHTSA's questions is in the docket of this NPRM.

⁷⁴ Electrical safety requirements in Europe, Japan, and Korea and SAE J1766 recognize voltage levels less than or equal to 30 VAC or 60 VDC as low voltage.

⁷⁵ Maximum value of touch current at which a person holding electrodes can let go of the electrodes.

⁷⁶ The Alliance also noted its belief that the indirect contact scenarios identified in the Battelle study are extremely rare and that in setting appropriate safety measures, the probability of faults, probability of contact with live parts, and the ratio of touch voltage and fault voltage needs to be considered.

⁷⁷ The Alliance did not specify a test procedure to determine electrical isolation between the high voltage source and its electrical protection barrier.

(same level of safety as that afforded by post-crash electrical isolation requirements).

NHTSA's Proposal for Physical Barrier Protection

In consideration of the above technical analysis, the agency is proposing to combine Alliance's suggested Option 1 and Option 2 requirements for electrical protection barriers. Specifically, the agency proposes the following requirements for an electrical protection barrier of a high voltage source:

- (1) Direct contact protection degree IPXXB,
- (2) indirect contact protection (electrical protection barriers are conductively connected to the chassis with resistance less than 0.1 ohms and resistance between two electrical protection barriers that are accessible within 2.5 meters is less than 0.2 ohms), and
- (3) low voltage of 30 VAC or 60VDC between the electrical protection barrier and other exposed conductive parts.

The first two conditions are specified in GTR No. 13 and (1) and (3) together is the same as Option 2 suggested by the Alliance. We concur that there is merit to the third condition since FMVSS No. 305 already recognizes voltages less than or equal to 30 VAC and 60 VDC as low voltage. Our technical analysis confirms that the proposed post-crash physical barrier protection option (with the first two requirements in GTR No. 13 and an additional third requirement that electrical protection barriers be low voltage) affords the same level of safety as the post-crash electrical isolation option currently in FMVSS No. 305.

NHTSA seeks comment on the proposed inclusion of the physical barrier protection option into FMVSS No. 305. NHTSA also seeks comment on its proposed physical barrier protection requirements which combine the requirements in GTR No. 13 and Option 2 in the Alliance petition. The agency also seeks comment on the proposed test procedures for assessing physical barrier protection.

Toyota's Request for Amending Post-Crash Test Procedure

In its December 23, 2013 petition for rulemaking, Toyota requests that NHTSA amend S6.4 of FMVSS No. 305, which requires a vehicle to satisfy all of the post-crash performance requirements "after being rotated on its longitudinal axis to each successive increment of 90 degrees. . . ." Toyota recommends that the tests to evaluate electrical isolation and physical barrier protection requirements be performed

after the vehicle is rotated a full 360 degrees. Toyota states that the vehicle conditions related to these requirements do not change at various increments of a rollover, and it would be increasingly dangerous for laboratory personnel to conduct the specified tests with the vehicle at other 90 degree increments.

NHTSA has evaluated Toyota's request and is denying it. NHTSA does not agree with Toyota's assessment that the vehicle conditions related to electrical safety requirements do not change at various increments of rollover. Post-crash direct contact protection is assessed by first opening, disassembling, or removing electrical protection barriers, solid insulator, and connectors without the use of tools, and then the IPXXB probe is used to determine if high voltage sources can be contacted. This evaluation may yield different results for the different attitudes of the vehicle. For example, high voltage sources may be more accessible when the vehicle is rotated 90 degrees than when upright. NHTSA is not aware of unreasonably dangerous conditions to laboratory personnel in conducting the specified tests with the vehicle at 90 degree increments. Toyota did not provide any supporting data to substantiate its case. NHTSA seeks comment on this issue.

X. Rulemaking Analyses and Notices

Executive Order 12866 and DOT Regulatory Policies and Procedures

This rulemaking document was not reviewed by the Office of Management and Budget under E.O. 12866. It is not considered to be significant under E.O. 12866 or the Department's Regulatory Policies and Procedures. The amendments proposed by this NPRM would have no significant effect on the national economy, as the requirements are already in voluntary industry standards and international standards that current electric powered vehicles presently meet.

This NPRM proposes to update FMVSS No. 305 to incorporate the electrical safety requirements in GTR No. 13. This proposal also responds to petitions for rulemaking from Toyota and the Alliance to facilitate the introduction of fuel cell vehicles and 48 volt mild hybrid technologies into the vehicle fleet. The proposal adds electrical safety requirements in GTR No. 13 that involves electrical isolation and direct and indirect contact protection of high voltage sources to prevent electric shock during normal operation of electric powered vehicles. Today's proposal also provides an additional optional method of meeting

post-crash electrical safety requirements in FMVSS No. 305 that involves physical barriers of high voltage sources to prevent electric shock due to direct and indirect contact with live parts. Since there is widespread conformance with the requirements that would apply to existing vehicles, we anticipate no costs or benefits associated with this rulemaking.

Regulatory Flexibility Act

NHTSA has considered the effects of this NPRM under the Regulatory Flexibility Act (5 U.S.C. 601 *et seq.*, as amended by the Small Business Regulatory Enforcement Fairness Act (SBREFA) of 1996). I certify that this NPRM would not have a significant economic impact on a substantial number of small entities. Any small manufacturers that might be affected by this NPRM are already subject to the requirements of FMVSS No. 305. Further, the agency believes the testing associated with the requirements added by this NPRM are not substantial and to some extent are already being voluntarily borne by the manufacturers pursuant to SAE J1766. Therefore, there will be only a minor economic impact.

National Environmental Policy Act

NHTSA has analyzed this rulemaking action for the purposes of the National Environmental Policy Act. The agency has determined that implementation of this action will not have any significant impact on the quality of the human environment.

Executive Order 13132 (Federalism)

NHTSA has examined today's NPRM pursuant to Executive Order 13132 (64 FR 43255; Aug. 10, 1999) and concluded that no additional consultation with States, local governments, or their representatives is mandated beyond the rulemaking process. The agency has concluded that the proposal does not have sufficient federalism implications to warrant consultation with State and local officials or the preparation of a federalism summary impact statement. The proposal does not have "substantial direct effects on the States, on the relationship between the national government and the States, or on the distribution of power and responsibilities among the various levels of government."

NHTSA rules can have preemptive effect in two ways. First, the National Traffic and Motor Vehicle Safety Act contains an express preemption provision:

When a motor vehicle safety standard is in effect under this chapter, a State or a political subdivision of a State may

prescribe or continue in effect a standard applicable to the same aspect of performance of a motor vehicle or motor vehicle equipment only if the standard is identical to the standard prescribed under this chapter. 49 U.S.C. 30103(b)(1).

It is this statutory command that preempts any non-identical State legislative and administrative law⁷⁸ addressing the same aspect of performance, not today's rulemaking, so consultation would be inappropriate.

Second, the Supreme Court has recognized the possibility, in some instances, of implied preemption of State requirements imposed on motor vehicle manufacturers, including sanctions imposed by State tort law. That possibility is dependent upon there being an actual conflict between a FMVSS and the State requirement. If and when such a conflict exists, the Supremacy Clause of the Constitution makes the State requirements unenforceable. See *Geier v. American Honda Motor Co.*, 529 U.S. 861 (2000), finding implied preemption of state tort law on the basis of a conflict discerned by the court,⁷⁹ not on the basis of an intent to preempt asserted by the agency itself.

NHTSA has considered the nature (e.g., the language and structure of the regulatory text) and objectives of today's NPRM and does not discern any existing State requirements that conflict with the rule or the potential for any future State requirements that might conflict with it. Without any conflict, there could not be any implied preemption of state law, including state tort law.

Executive Order 12988 (Civil Justice Reform)

With respect to the review of the promulgation of a new regulation, section 3(b) of Executive Order 12988, "Civil Justice Reform" (61 FR 4729; Feb. 7, 1996), requires that Executive agencies make every reasonable effort to ensure that the regulation: (1) Clearly specifies the preemptive effect; (2) clearly specifies the effect on existing Federal law or regulation; (3) provides a clear legal standard for affected conduct, while promoting simplification and burden reduction; (4) clearly specifies the retroactive effect, if any; (5) specifies whether administrative proceedings are to be required before

parties file suit in court; (6) adequately defines key terms; and (7) addresses other important issues affecting clarity and general draftsmanship under any guidelines issued by the Attorney General. This document is consistent with that requirement.

Pursuant to this Order, NHTSA notes as follows. The issue of preemption is discussed above. NHTSA notes further that there is no requirement that individuals submit a petition for reconsideration or pursue other administrative proceedings before they may file suit in court.

Privacy Act

Please note that anyone is able to search the electronic form of all comments received into any of our dockets by the name of the individual submitting the comment (or signing the comment, if submitted on behalf of an association, business, labor union, etc.). You may review DOT's complete Privacy Act Statement in the **Federal Register** published on April 11, 2000 (65 FR 19477-78), or online at <http://www.dot.gov/privacy.html>.

Paperwork Reduction Act

Under the Paperwork Reduction Act of 1995 (PRA), a person is not required to respond to a collection of information by a Federal agency unless the collection displays a valid OMB control number. There are no information collection requirements associated with this NPRM.

National Technology Transfer and Advancement Act

Section 12(d) of the National Technology Transfer and Advancement Act of 1995 (NTTAA), Public Law 104-113, as amended by Public Law 107-107 (15 U.S.C. 272), directs the agency to evaluate and use voluntary consensus standards in its regulatory activities unless doing so would be inconsistent with applicable law or is otherwise impractical. Voluntary consensus standards are technical standards (e.g., materials specifications, test methods, sampling procedures, and business practices) that are developed or adopted by voluntary consensus standards bodies, such as the Society of Automotive Engineers (SAE). The NTTAA directs us to provide Congress (through OMB) with explanations when the agency decides not to use available and applicable voluntary consensus standards. The NTTAA does not apply to symbols.

FMVSS No. 305 has historically drawn largely from SAE J1766, and does so again for this current rulemaking, which proposes revisions to FMVSS No.

305 to facilitate the development of fuel cell and 48 volt mild hybrid technologies. It is based on GTR No. 13 and the latest version of SAE J1766 January 2014.

Unfunded Mandates Reform Act

Section 202 of the Unfunded Mandates Reform Act of 1995 (UMRA), Public Law 104-4, requires Federal agencies to prepare a written assessment of the costs, benefits, and other effects of proposed or final rules that include a Federal mandate likely to result in the expenditure by State, local, or tribal governments, in the aggregate, or by the private sector, of more than \$100 million annually (adjusted for inflation with base year of 1995). Adjusting this amount by the implicit gross domestic product price deflator for the year 2013 results in \$142 million (106.733/75.324 = 1.42). This NPRM would not result in a cost of \$142 million or more to either State, local, or tribal governments, in the aggregate, or the private sector. Thus, this NPRM is not subject to the requirements of sections 202 of the UMRA.

Executive Order 13609 (Promoting Regulatory Cooperation)

The policy statement in section 1 of Executive Order 13609 provides, in part: The regulatory approaches taken by foreign governments may differ from those taken by U.S. regulatory agencies to address similar issues. In some cases, the differences between the regulatory approaches of U.S. agencies and those of their foreign counterparts might not be necessary and might impair the ability of American businesses to export and compete internationally. In meeting shared challenges involving health, safety, labor, security, environmental, and other issues, international regulatory cooperation can identify approaches that are at least as protective as those that are or would be adopted in the absence of such cooperation. International regulatory cooperation can also reduce, eliminate, or prevent unnecessary differences in regulatory requirements.

The agency participated in the development of GTR No. 13 to harmonize the standards of fuel cell vehicles. As a signatory member, NHTSA is proposing to incorporate electrical safety requirements and options specified in GTR No. 13 into FMVSS No. 305.

Regulation Identifier Number

The Department of Transportation assigns a regulation identifier number (RIN) to each regulatory action listed in the Unified Agenda of Federal

⁷⁸The issue of potential preemption of state tort law is addressed in the immediately following paragraph discussing implied preemption.

⁷⁹The conflict was discerned based upon the nature (e.g., the language and structure of the regulatory text) and the safety-related objectives of FMVSS requirements in question and the impact of the State requirements on those objectives.

Regulations. The Regulatory Information Service Center publishes the Unified Agenda in April and October of each year. You may use the RIN contained in the heading at the beginning of this document to find this action in the Unified Agenda.

Plain Language

Executive Order 12866 requires each agency to write all rules in plain language. Application of the principles of plain language includes consideration of the following questions:

- Have we organized the material to suit the public's needs?
- Are the requirements in the rule clearly stated?
- Does the rule contain technical language or jargon that isn't clear?
- Would a different format (grouping and order of sections, use of headings, paragraphing) make the rule easier to understand?
- Would more (but shorter) sections be better?
- Could we improve clarity by adding tables, lists, or diagrams?
- What else could we do to make the rule easier to understand?

If you have any responses to these questions, please write to us with your views.

XI. Public Participation

How do I prepare and submit comments?

Your comments must be written and in English. To ensure that your comments are correctly filed in the Docket, please include the docket number of this document in your comments.

Your comments must not be more than 15 pages long. (49 CFR 553.21). We established this limit to encourage you to write your primary comments in a concise fashion. However, you may attach necessary additional documents to your comments. There is no limit on the length of the attachments.

Comments may also be submitted to the docket electronically by logging onto the Docket Management System Web site at <http://www.regulations.gov>. Follow the online instructions for submitting comments.

Please note that pursuant to the Data Quality Act, in order for substantive data to be relied upon and used by the agency, it must meet the information quality standards set forth in the OMB and DOT Data Quality Act guidelines. Accordingly, we encourage you to consult the guidelines in preparing your comments. OMB's guidelines may be accessed at <http://www.whitehouse.gov/omb/fedreg/reproducible.html>.

How can I be sure that my comments were received?

If you wish Docket Management to notify you upon its receipt of your comments, enclose a self-addressed, stamped postcard in the envelope containing your comments. Upon receiving your comments, Docket Management will return the postcard by mail.

How do I submit confidential business information?

If you wish to submit any information under a claim of confidentiality, you should submit three copies of your complete submission, including the information you claim to be confidential business information, to the Chief Counsel, NHTSA, at the address given above under **FOR FURTHER INFORMATION CONTACT**. In addition, you should submit a copy, from which you have deleted the claimed confidential business information, to the docket at the address given above under **ADDRESSES**. When you send a comment containing information claimed to be confidential business information, you should include a cover letter setting forth the information specified in our confidential business information regulation. (49 CFR part 512)

Will the agency consider late comments?

We will consider all comments received before the close of business on the comment closing date indicated above under **DATES**. To the extent possible, we will also consider comments that the docket receives after that date. If the docket receives a comment too late for us to consider in developing a final rule (assuming that one is issued), we will consider that comment as an informal suggestion for future rulemaking action.

How can I read the comments submitted by other people?

You may read the comments received by the docket at the address given above under **ADDRESSES**. The hours of the docket are indicated above in the same location. You may also see the comments on the Internet. To read the comments on the Internet, go to <http://www.regulations.gov>. Follow the online instructions for accessing the dockets.

Please note that even after the comment closing date, we will continue to file relevant information in the docket as it becomes available. Further, some people may submit late comments. Accordingly, we recommend that you periodically check the Docket for new material. You can arrange with the docket to be notified when others file

comments in the docket. See www.regulations.gov for more information.

List of Subjects in 49 CFR Part 571

Imports, Motor vehicles, Motor vehicle safety.

In consideration of the foregoing, NHTSA proposes to amend 49 CFR part 571 as follows:

PART 571—FEDERAL MOTOR VEHICLE SAFETY STANDARDS

- 1. The authority citation for part 571 continues to read as follows:

Authority: 49 U.S.C. 322, 30111, 30115, 30117, and 30166; delegation of authority at 49 CFR 1.95.

- 2. In § 571.305:
 - a. Revise S1 and S2;
 - b. Under S4:
 - i. Add in alphabetical order definitions for “Charge connector”, “Direct contact”, “Electrical protection barrier”, “Exposed conductive part”, “External electric power supply”, “Fuel cell system”, “Indirect contact”, “Live part”, “Luggage compartment”, “Passenger compartment”, and “Possible active driving mode”;
 - ii. Revise the definition of “Propulsion system”; and
 - iii. Add in alphabetical order definitions for “Protection degree IPXXB”, “Protection degree IPXXD”, “Service disconnect”, and “Vehicle charge inlet”;
 - c. Revise S5.3 and S5.4; and
 - d. Add S5.4.1, S5.4.1.1, S5.4.1.1.1, S5.4.1.2, S5.4.1.3, S5.4.1.4, S5.4.2, S5.4.2.1, S5.4.2.2, S5.4.3, S5.4.3.1, S5.4.3.2, S5.4.3.3, S5.4.4, S5.4.5, S5.4.6, S5.4.6.1, S5.4.6.2, S5.4.6.3, S9, S9.1, S9.2, S9.3, and figures 6, 7a, 7b, and 8.

The revisions and additions read as follows:

§ 571.305 Standard No. 305; Electric-powered vehicles: electrolyte spillage and electrical shock protection.

S1. *Scope.* This standard specifies requirements for limitation of electrolyte spillage and retention of electric energy storage/conversion devices during and after a crash, and protection from harmful electric shock during and after a crash and during normal vehicle operation.

S2. *Purpose.* The purpose of this standard is to reduce deaths and injuries during and after a crash that occur because of electrolyte spillage from electric energy storage devices, intrusion of electric energy storage/conversion devices into the occupant compartment, and electrical shock, and to reduce deaths and injuries during

normal vehicle operation that occur because of electric shock.

* * * * *
S4. Definitions.
* * * * *

Charge connector is a conductive device that, by insertion into a vehicle charge inlet, establishes an electrical connection of the vehicle to the external electric power supply for the purpose of transferring energy and exchanging information.

Direct contact is the contact of persons with high voltage live parts.
* * * * *

Electrical protection barrier is the part providing protection against direct contact with live parts from any direction of access.

Exposed conductive part is the conductive part that can be touched under the provisions of the IPXXB protection degree and becomes electrically energized under isolation failure conditions. This includes parts under a cover that can be removed without using tools.

External electric power supply is a power supply external to the vehicle that provides electric power to charge the propulsion battery in the vehicle.

Fuel cell system is a system containing the fuel cell stack(s), air processing system, fuel flow control system, exhaust system, thermal management system, and water management system.
* * * * *

Indirect contact is the contact of persons with exposed conductive parts.

Live part is a conductive part of the vehicle that is electrically energized under normal vehicle operation.

Luggage compartment is the space in the vehicle for luggage accommodation, separated from the passenger compartment by the front or rear bulkhead and bounded by a roof, hood, floor, and side walls, as well as by the electrical barrier and enclosure provided for protecting the power train from direct contact with live parts.

Passenger compartment is the space for occupant accommodation that is bounded by the roof, floor, side walls, doors, outside glazing, front bulkhead and rear bulkhead or rear gate, as well as electrical barriers and enclosures provided for protecting the occupants from direct contact with live parts.

Possible active driving mode is the vehicle mode when application of pressure to the accelerator pedal (or activation of an equivalent control) or release of the brake system causes the electric power train to move the vehicle.

Propulsion system means an assembly of electric or electro-mechanical

components or circuits that propel the vehicle using the energy that is supplied by a high voltage source. This includes, but is not limited to, electric motors, inverters/converters, and electronic controllers.

Protection degree IPXXB is protection from contact with high voltage live parts. It is tested by probing electrical protection barriers or enclosures with the jointed test finger probe, IPXXB, in Figure 7b.

Protection degree IPXXD is protection from contact with high voltage live parts. It is tested by probing electrical protection barriers or enclosures with the test wire probe, IPXXD, in Figure 7a.

Service disconnect is the device for deactivation of an electrical circuit when conducting checks and services of the vehicle electrical propulsion system.
* * * * *

Vehicle charge inlet is the device on the electric vehicle into which the charge connector is inserted for the purpose of transferring energy and exchanging information from an external electric power supply.
* * * * *

S5.3 *Electrical safety.* After each test specified in S6 of this standard, each high voltage source in a vehicle must meet the electrical isolation requirements of paragraph S5.3(a) of this section, the voltage level requirements of paragraph S5.3(b) of this section, or the physical barrier protection requirements of paragraph S5.3(c) of this section.

(a) The electrical isolation of the high voltage source, determined in accordance with the procedure specified in S7.6 of this section, must be greater than or equal to one of the following:

(1) 500 ohms/volt for an AC high voltage source; or

(2) 100 ohms/volt for an AC high voltage source if it is conductively connected to a DC high voltage source, but only if the AC high voltage source meets the physical barrier protection requirements specified in paragraph S5.3(c) of this section; or

(3) 100 ohms/volt for a DC high voltage source.

(b) The voltages V1, V2, and Vb of the high voltage source, measured according to the procedure specified in S7.7 of this section, must be less than or equal to 30 VAC for AC components or 60 VDC for DC components.

(c) Protection against electric shock by direct and indirect contact (physical barrier protection) shall be demonstrated by meeting the following three conditions:

(1) The high voltage source (AC or DC) meets the protection degree IPXXB

when tested under the procedure specified in S9.1 of this section using the IPXXB test probe shown in Figures 7a and 7b to this section;

(2) The resistance between exposed conductive parts of the electrical protection barriers and the electrical chassis is less than 0.1 ohms when tested under the procedures specified in S9.2 of this section. In addition, the resistance between any two simultaneously reachable exposed conductive parts of the electrical protection barriers that are less than 2.5 meters from each other is less than 0.2 ohms when tested under the procedures specified in S9.2 of this section; and

(3) The voltages between the electrical protection barrier enclosing the high voltage source and other exposed conductive parts are less than or equal to 30 VAC or 60 VDC as measured in accordance with S9.3 of this section.

S5.4 *Electrical safety during normal vehicle operation.*

S5.4.1 *Protection against direct contact.*

S5.4.1.1 *Marking.* The symbol shown in Figure 6 to this section shall be visible on or near electric energy storage/conversion devices. The symbol in Figure 6 to this section shall also be visible on electrical protection barriers which, when removed, expose live parts of high voltage sources. The symbol shall be yellow and the bordering and the arrow shall be black.

S5.4.1.1.1 The marking is not required for electrical protection barriers that cannot be physically accessed, opened, or removed without the use of tools.

S5.4.1.1.2 *High voltage cables.* Cables for high voltage sources which are not located within enclosures shall be identified by having an outer covering with the color orange.

S5.4.1.1.3 *Service disconnect.* For a service disconnect which can be opened, disassembled, or removed without tools, protection degree IPXXB shall be provided when tested under procedures specified in S9.1 of this section using the IPXXB test probe shown in Figures 7a and 7b to this section.

S5.4.1.1.4 *Protection degree of high voltage sources and live parts.*

(a) Protection degree IPXXD shall be provided for live parts and high voltage sources inside the passenger or luggage compartment when tested under procedures specified in S9.1 of this section using the IPXXD test probe shown in Figure 7a to this section.

(b) Protection degree IPXXB shall be provided for live parts and high voltage sources in areas other than the passenger or luggage compartment when

tested under procedures specified in S9.1 of this section using the IPXXB test probe shown in Figures 7a and 7b to this section.

S5.4.2 Protection against indirect contact.

S5.4.2.1 The resistance between all exposed conductive parts and the electrical chassis shall be less than 0.1 ohms when tested under the procedures specified in S9.2 of this section.

S5.4.2.2 The resistance between any two simultaneously reachable exposed conductive parts of the electrical protection barriers that are less than 2.5 meters from each other shall not exceed 0.2 ohms when tested under the procedures specified in S9.2 of this section.

S5.4.3 Electrical isolation.

S5.4.3.1 *Electrical isolation of AC and DC high voltage sources.* The electrical isolation of a high voltage source, determined in accordance with the procedure specified in S7.6 of this section must be greater than or equal to one of the following:

(a) 500 ohms/volt for an AC high voltage source;

(b) 100 ohms/volt for an AC high voltage source if it is conductively connected to a DC high voltage source, but only if the AC high voltage source meets the requirements for protection against direct contact in S5.4.1.4 of this section and the protection from indirect contact in S5.4.2 of this section; or

(c) 100 ohms/volt for a DC high voltage source.

S5.4.3.2 *Exclusion of high voltage sources from electrical isolation requirements.* A high voltage source that is conductively connected to an electric energy storage device which is conductively connected to the electrical chassis and has a working voltage less than or equal to 60 VDC, is not required to meet the electrical isolation requirements in S5.4.3.1 of this section during normal vehicle operating conditions if the voltage between the high voltage source and the electrical chassis is less than or equal to 30 VAC or 60 VDC.

S5.4.3.3 *Isolation resistance of high voltage sources for charging the electric energy storage device.* For motor vehicles with an electric energy storage device that can be charged through a conductive connection with the grounded external electric power supply, the isolation resistance between the electrical chassis and the vehicle charge inlet and each high voltage source conductively connected to the vehicle charge inlet during charging of the electric energy storage device shall be a minimum of one million ohms when the charge connector is

disconnected. The isolation resistance is determined in accordance with the procedure specified in S7.6 of this section.

S5.4.4 *Electrical isolation monitoring.* Each DC high voltage sources of vehicles with a fuel cell system shall be monitored by an electrical isolation monitoring system that displays a warning for loss of isolation when tested according to S8 of this section. The system must monitor its own readiness and the warning display must be visible to the driver seated in the driver's designated seating position.

S5.4.5 *Electric shock protection during charging.* For motor vehicles with an electric energy storage device that can be charged through a conductive connection with a grounded external electric power supply, a device to enable conductive connection of the electrical chassis to the earth ground shall be provided. This device shall enable connection to the earth ground before exterior voltage is applied to the vehicle and retain the connection until after the exterior voltage is removed from the vehicle.

S5.4.6 Mitigating driver error.

S5.4.6.1 *Indicator of possible active driving mode at start up.* At least a momentary indication shall be given to the driver when the vehicle is in possible active driving mode. This requirement does not apply under conditions where an internal combustion engine provides directly or indirectly the vehicle's propulsion power upon start up.

S5.4.6.2 *Indicator of possible active driving mode when leaving the vehicle.* When leaving the vehicle, the driver shall be informed by an audible or visual signal if the vehicle is still in the possible active driving mode.

S5.4.6.3 *Prevent drive-away during charging.* If the on-board electric energy storage device can be externally charged, vehicle movement by its own propulsion system shall not be possible as long as the charge connector of the external electric power supply is physically connected to the vehicle charge inlet.

* * * * *

S9 *Test methods for physical barrier protection from electric shock due to direct and indirect contact with high voltage sources.*

S9.1 *Test method to evaluate protection from direct contact with high voltage sources.*

(a) Any parts surrounding the high voltage components are opened, disassembled, or removed without the use of tools.

(b) The selected access probe is inserted into any gaps or openings of the electrical protection barrier with a test force of $10\text{ N} \pm 1\text{ N}$ with the IPXXB probe or $1\text{ to }2\text{ N}$ with the IPXXD probe. If partial or full penetration into the physical barrier occurs, the probe shall be placed as follows: Starting from the straight position, both joints of the test finger are rotated progressively through an angle of up to 90 degrees with respect to the axis of the adjoining section of the test finger and are placed in every possible position.

(c) A low voltage supply (of not less than 40 V and not more than 50 V) in series with a suitable lamp may be connected between the access probe and any high voltage live parts inside the physical barrier to indicate whether live parts were contacted.

(d) A mirror or fibroscope may be used to inspect whether the access probe touches high voltage parts inside the physical barrier.

S9.2 *Test method to evaluate protection against indirect contact with high voltage sources.*

(a) *Test method using a resistance tester.* The resistance tester is connected to the measuring points (the electrical chassis and any exposed conductive part of the vehicle or any two exposed conductive parts that are less than 2.5 meters from each other), and the resistance is measured using a resistance tester that can measure current levels of at least 0.1 Amperes with a resolution of 0.01 ohms or less.

(b) *Test method using a DC power supply, voltmeter and ammeter.*

(1) Connect the DC power supply, voltmeter and ammeter to the measuring points (the electrical chassis and any exposed conductive part or any two exposed conductive parts that are less than 2.5 meters from each other) as shown in Figure 8 to this section.

(2) Adjust the voltage of the DC power supply so that the current flow becomes more than 0.2 Amperes.

(3) Measure the current I and the voltage V shown in Figure 8 to this section.

(4) Calculate the resistance R according to the formula, $R=V/I$.

S9.3 *Test method to determine voltage between electrical protection barrier and exposed conductive parts, including electrical chassis, of the vehicle.*

(a) Connect the DC power supply and voltmeter to the measuring points (exposed conductive part of an electrical protection barrier and the electrical chassis or any other exposed conductive part of the vehicle).

(b) Measure the voltage.

(c) After completing the voltage measurements for all electrical protection barriers, the voltage differences between all exposed

conductive parts of the protective barriers shall be calculated.

* * * * *

BILLING CODE 4910-59-P

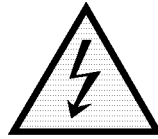

Figure 6. Marking of High Voltage Equipment.

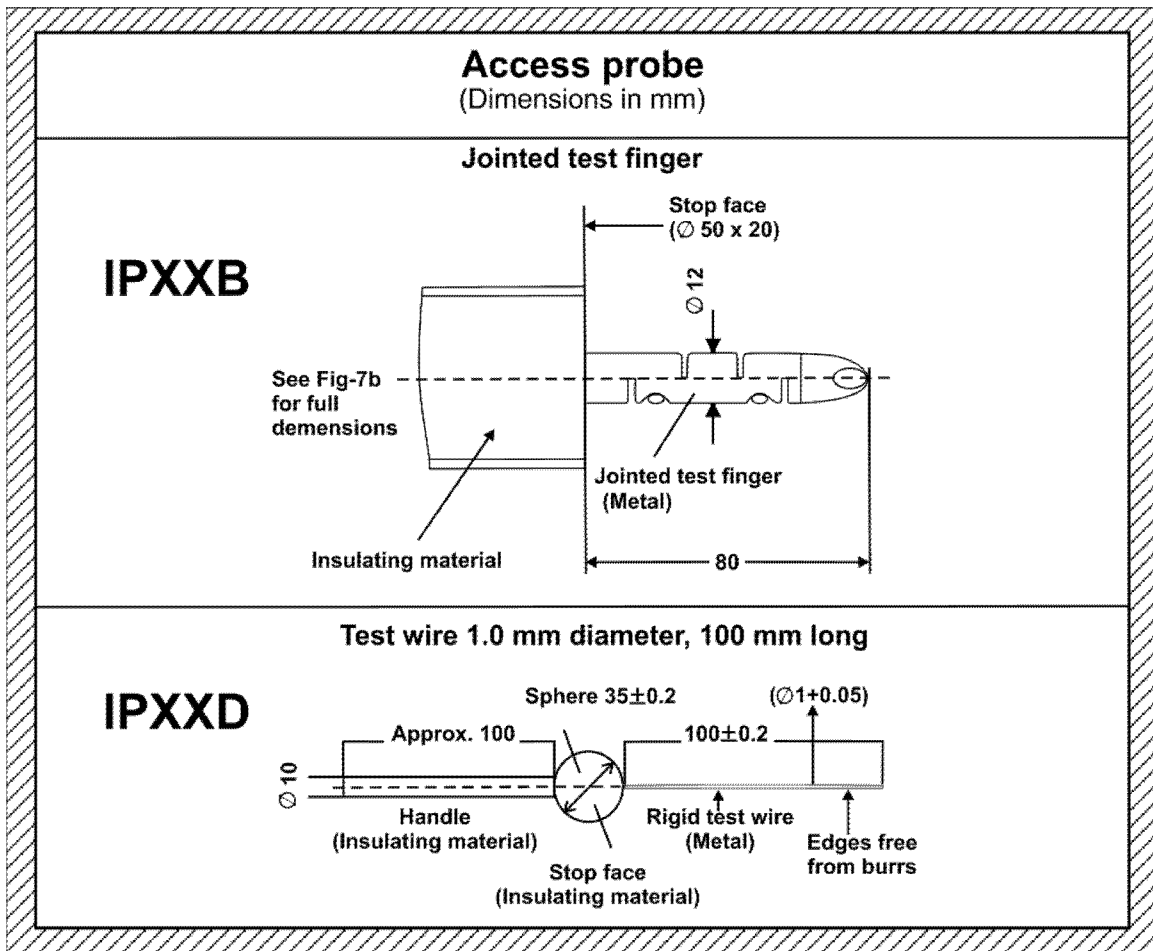
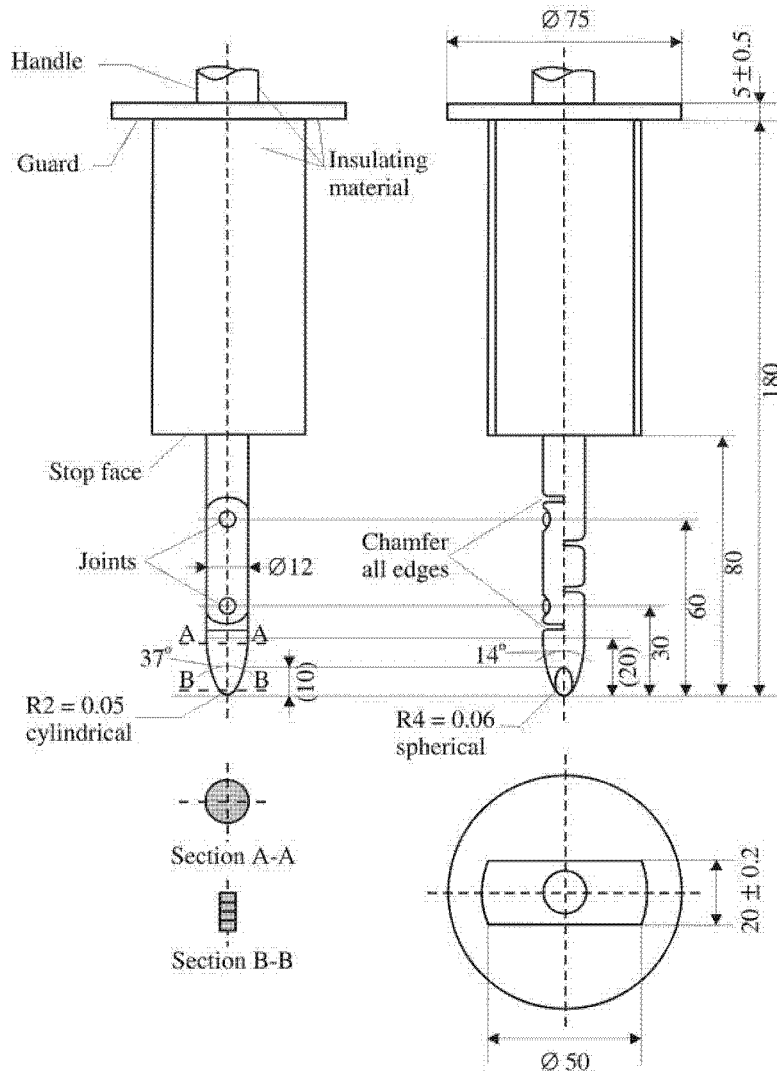

Figure 7a. Access Probes for the Tests of Direct Contact Protection



Material: metal, except where otherwise specified

Linear dimensions in millimeters

Tolerances on dimensions without specific tolerance:

on angles, 0/10 degrees

on linear dimensions:

up to 25 mm: 0/-0.05 mm

over 25 mm: ± 0.2 mm

Both joints shall permit movement in the same plane and the same direction through an angle of 90° with a 0° to $+10^\circ$ tolerance.

Figure 7b. Jointed Test Finger IPXXB

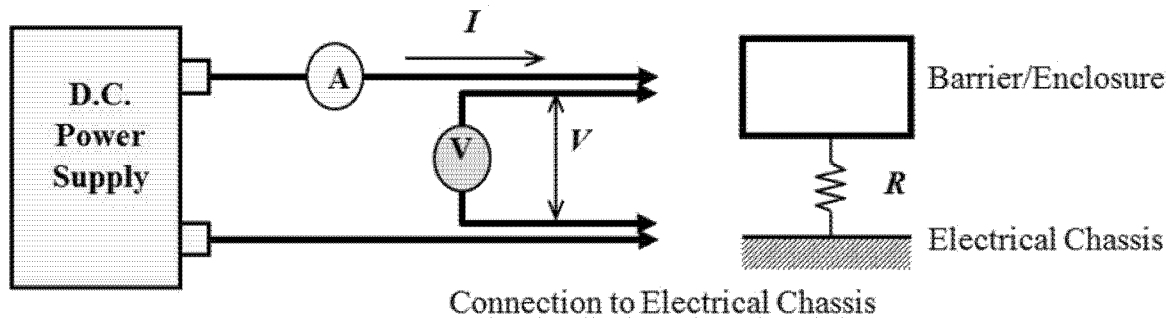

Figure 8. Connection to Determine Resistance between Physical Barrier and Electrical Chassis

Raymond R. Posten,

Associate Administrator for Rulemaking.

[FR Doc. 2016-05187 Filed 3-9-16; 8:45 am]

BILLING CODE 4910-59-C

DEPARTMENT OF COMMERCE

National Oceanic and Atmospheric Administration

50 CFR Part 660

[Docket No. 160126053-6053-01]

RIN 0648-BF74

Magnuson-Stevens Act Provisions; Fisheries off West Coast States; Pacific Coast Groundfish Fishery; 2016 Tribal Fishery for Pacific Whiting

AGENCY: National Marine Fisheries Service (NMFS), National Oceanic and Atmospheric Administration (NOAA), Commerce.

ACTION: Proposed rule; request for comments.

SUMMARY: NMFS issues this proposed rule for the 2016 Pacific whiting fishery under the authority of the Pacific Coast Groundfish Fishery Management Plan (FMP), the Magnuson Stevens Fishery Conservation and Management Act (Magnuson-Stevens Act), and the Pacific Whiting Act of 2006. This proposed rule would allocate 17.5% of the U.S. Total Allowable Catch of Pacific whiting for 2016 to Pacific Coast Indian tribes that have a Treaty right to harvest groundfish.

DATES: Comments on this proposed rule must be received no later than April 11, 2016.

ADDRESSES: You may submit comments on this document, identified by NOAA-NMFS-2016-0009, by any of the following methods:

- **Electronic Submission:** Submit all electronic public comments via the Federal eRulemaking Portal. Go to www.regulations.gov/ #!docketDetail;D=NOAA-NMFS-2016-0009, click the “Comment Now!” icon, complete the required fields, and enter or attach your comments.

- **Mail:** William W. Stelle, Jr., Regional Administrator, Northwest Region, NMFS, 7600 Sand Point Way NE., Seattle, WA 98115-0070, Attn: Miako Ushio.

Instructions: Comments sent by any other method, to any other address or individual, or received after the end of the comment period, may not be considered by NMFS. All comments received are part of the public record and will generally be posted for public viewing on www.regulations.gov without change. All personal identifying information (e.g., name, address, etc.), confidential business information, or otherwise sensitive information submitted voluntarily by the sender will be publicly accessible. NMFS will accept anonymous comments (enter “N/A” in the required fields if you wish to remain anonymous).

FOR FURTHER INFORMATION CONTACT: Miako Ushio (West Coast Region, NMFS), phone: 206-526-4644, and email: miako.ushio@noaa.gov.

SUPPLEMENTARY INFORMATION:

Electronic Access

This proposed rule is accessible via the Internet at the Office of the Federal Register Web site at <https://www.federalregister.gov/>. Background information and documents are available at the NMFS West Coast Region Web site at http://www.westcoast.fisheries.noaa.gov/fisheries/management/whiting/pacific_whiting.html and at the Pacific Fishery Management Council’s Web site at <http://www.pcouncil.org/>.

Background

The regulations at 50 CFR 660.50(d) establish the process by which the tribes with treaty fishing rights in the area covered by the Pacific Coast Groundfish Fishery Management Plan (FMP) request new allocations or regulations specific to the tribes, in writing, during the biennial harvest specifications and management measures process. The regulations state that the Secretary will develop tribal allocations and regulations in consultation with the affected tribe(s) and, insofar as possible, with tribal consensus. The procedures NMFS employs in implementing tribal treaty rights under the FMP were designed to provide a framework process by which NMFS can accommodate tribal treaty rights by setting aside appropriate amounts of fish in conjunction with the Pacific Fishery Management Council (Council) process for determining harvest specifications and management measures.

Since the FMP has been in place, NMFS has been allocating a portion of the U.S. total allowable catch (TAC) (called Optimum Yield (OY) or Annual Catch Limit (ACL) prior to 2012) of Pacific whiting to the tribal fishery, following the process established in 50 CFR 660.50(d). The tribal allocation is subtracted from the U.S. Pacific whiting TAC before allocation to the non-tribal sectors.

There are four tribes that can participate in the tribal whiting fishery: the Hoh Tribe, the Makah Tribe, the Quileute Tribe, and the Quinault Indian Nation (collectively, the “Treaty Tribes”). The Hoh Tribe has not expressed an interest in participating to date. The Quileute Tribe and Quinault Indian Nation have expressed interest in participating in the whiting fishery. However, to date, only the Makah Tribe has prosecuted a tribal fishery for