

station 209.78 frame ring, before further flight, the proposed AD would require modifying that location by fabricating and installing a doubler over the location in accordance with the previously-described service information.

Costs of Compliance

We estimate that this proposed AD would affect 109 helicopters of U.S. registry. We estimate that operators may incur the following costs in order to comply with this AD. \$340 for 4 work hours to access and measure for a short-edge margin condition at \$85 per hour for a total of \$37,060 for the fleet.

The on-condition costs for installing the doubler are not included in our cost estimate because we have no way of determining the number of aircraft that might need a doubler, which would require about 8 work hours at \$85 per hour for a total of \$699 additional labor for each helicopter and \$19 for required parts.

Authority for This Rulemaking

Title 49 of the United States Code specifies the FAA's authority to issue rules on aviation safety. Subtitle I, section 106, describes the authority of the FAA Administrator. "Subtitle VII: Aviation Programs," describes in more detail the scope of the Agency's authority.

We are issuing this rulemaking under the authority described in "Subtitle VII, Part A, Subpart III, Section 44701: General requirements." Under that section, Congress charges the FAA with promoting safe flight of civil aircraft in air commerce by prescribing regulations for practices, methods, and procedures the Administrator finds necessary for safety in air commerce. This regulation is within the scope of that authority because it addresses an unsafe condition that is likely to exist or develop on products identified in this rulemaking action.

Regulatory Findings

We determined that this proposed AD would not have federalism implications under Executive Order 13132. This proposed AD would not have a substantial direct effect on the States, on the relationship between the national Government and the States, or on the distribution of power and responsibilities among the various levels of government.

For the reasons discussed, I certify this proposed regulation:

1. Is not a "significant regulatory action" under Executive Order 12866;

2. Is not a "significant rule" under the DOT Regulatory Policies and Procedures (44 FR 11034, February 26, 1979);

3. Will not affect intrastate aviation in Alaska to the extent that it justifies making a regulatory distinction; and

4. Will not have a significant economic impact, positive or negative, on a substantial number of small entities under the criteria of the Regulatory Flexibility Act.

We prepared an economic evaluation of the estimated costs to comply with this proposed AD and placed it in the AD docket.

List of Subjects in 14 CFR Part 39

Air transportation, Aircraft, Aviation safety, Incorporation by Reference, Safety.

The Proposed Amendment

Accordingly, under the authority delegated to me by the Administrator, the FAA proposes to amend 14 CFR part 39 as follows:

PART 39—AIRWORTHINESS DIRECTIVES

1. The authority citation for part 39 continues to read as follows:

Authority: 49 U.S.C. 106(g), 40113, 44701.

§ 39.13 [Amended]

2. The FAA amends § 39.13 by adding the following new Airworthiness Directive (AD):

Hughes Helicopters Inc., and McDonnell Douglas Helicopter Systems (Type Certificate currently held by MD Helicopters, Inc. (MDHI)): Docket No. FAA-2012-0890; Directorate Identifier 2011-SW-019-AD.

(a) Applicability

This AD applies to Model 369D, E, F, and FF helicopters with tailboom assembly, part number (P/N) 369D23500-505, -507, -511, or -513 with a serial number prefix of "7604" and -0001 through -0003, -0006 through -0047, -0049 through -0082, or -0084 through -0113, installed, certificated in any category.

(b) Unsafe Condition

This AD defines the unsafe condition as too short an edge distance from an aft longeron rivet to the edge of a tailboom frame ring, which could result in failure of the tailboom and subsequent loss of control of the helicopter.

(c) Compliance

You are responsible for performing each action required by this AD within the specified compliance time unless it has already been accomplished prior to that time.

(d) Required Actions

(1) Within 6 months or 100 hours time-in-service, whichever occurs first, measure the distance from the aft face of the station

209.78 frame ring to the center of rivet No. 1 and rivet No. 2 at the four locations where the frame ring attaches to the tailboom longeron as depicted in Figure 2 of MD Helicopters Service Bulletin (SB) No. SB369D-207, SB369E-102, and SB369F-087, dated July 20, 2010. SB369D-207 applies to the Model 369D helicopters; SB369E-102 applies to the Model 369E helicopters; and SB369F-087 applies to Model 369F and FF helicopters.

Note to paragraph (d)(1) of this AD: The one MD Helicopters SB, dated July 20, 2010, contains three different numbers: SB369D-207; SB369E-102; and SB369F-087.

(2) If either the No. 1 or No. 2 aft rivet at a frame-ring-to-tailboom-longeron location is more than 0.50 inches (12.7 millimeters) from the aft face of the station 209.78 frame ring, before further flight, modify that location by fabricating and installing a doubler over the location as depicted in Figures 3 and 4 and by following the Accomplishment Instructions, paragraph 2.C., of the SB for your model helicopter.

(e) Alternative Methods of Compliance (AMOC)

(1) The Manager, Los Angeles Aircraft Certification Office, FAA, may approve AMOCs for this AD. Send your proposal to John Cecil, Aerospace Engineer, FAA, Los Angeles Aircraft Certification Office, Airframe Branch, 3960 Paramount Blvd., Lakewood, California 90712-4137, telephone (562) 627-5228, fax (562) 627-5210, email john.cecil@faa.gov.

(2) For operations conducted under a 14 CFR part 119 operating certificate or under 14 CFR part 91, subpart K, we suggest that you notify your principal inspector, or lacking a principal inspector, the manager of the local flight standards district office or certificate holding district office before operating any aircraft complying with this AD through an AMOC.

(f) Subject

Joint Aircraft System Component (JASC) Code 5302: Rotorcraft Tailboom.

Issued in Fort Worth, Texas, on August 16, 2012.

Kim Smith,

Manager, Rotorcraft Directorate, Aircraft Certification Service.

[FR Doc. 2012-21277 Filed 8-28-12; 8:45 am]

BILLING CODE 4910-13-P

DEPARTMENT OF TRANSPORTATION

Federal Aviation Administration

14 CFR Part 39

[Docket No. FAA-2012-0887; Directorate Identifier 2009-SW-02-AD]

RIN 2120-AA64

Airworthiness Directives; Eurocopter Deutschland GmbH Helicopters

AGENCY: Federal Aviation Administration (FAA), DOT.

ACTION: Notice of proposed rulemaking (NPRM).

SUMMARY: We propose to adopt a new airworthiness directive (AD) for Eurocopter Deutschland GmbH (ECD) Model BO-105A, BO-105C, BO-105S, BO-105LS A-1, BO-105LS A-3, MBB-BK 117 A-1, MBB-BK 117 A-3, MBB-BK 117 A-4, MBB-BK 117 B-1, MBB-BK-117 B-2, and MBB-BK 117 C-1 helicopters to require inspections for corrosion or thread damage to each tail rotor balance weight (weight) and each tail rotor control lever (lever). This proposed AD is prompted by a European Aviation Safety Agency (EASA) AD and a Transport Canada Civil Aviation (TCCA) AD, both issued based on a report that corrosion was detected on a weight in the area of the attachment thread on a model BO-105 helicopter. The proposed actions are intended to detect corrosion and thread damage in the threaded area of the weight and lever, and to prevent failure of a weight or lever, separation of tail rotor parts, severe vibration, and subsequent loss of control of the helicopter.

DATES: We must receive comments on this proposed AD by October 29, 2012.

ADDRESSES: You may send comments by any of the following methods:

- *Federal eRulemaking Docket:* Go to <http://www.regulations.gov>. Follow the online instructions for sending your comments electronically.

- *Fax:* 202-493-2251.

- *Mail:* Send comments to the U.S. Department of Transportation, Docket Operations, M-30, West Building Ground Floor, Room W12-140, 1200 New Jersey Avenue SE., Washington, DC 20590-0001.

- *Hand Delivery:* Deliver to the "Mail" address between 9 a.m. and 5 p.m., Monday through Friday, except Federal holidays.

Examining the AD Docket: You may examine the AD docket on the Internet at <http://www.regulations.gov> or in person at the Docket Operations Office between 9 a.m. and 5 p.m., Monday through Friday, except Federal holidays. The AD docket contains this proposed AD, the economic evaluation, any comments received, and other information. The street address for the Docket Operations Office (telephone 800-647-5527) is in the **ADDRESSES** section. Comments will be available in the AD docket shortly after receipt.

For service information identified in this proposed AD, contact American Eurocopter Corporation, 2701 Forum Drive, Grand Prairie, TX 75053-4005; telephone (972) 641-3460; fax (972)

641-3527; or at <http://www.eurocopter.com>. You may review the referenced service information at the FAA, Office of the Regional Counsel, Southwest Region, 2601 Meacham Blvd., Room 663, Fort Worth, TX 76137.

FOR FURTHER INFORMATION CONTACT: Sharon Miles, Aviation Safety Engineer, Regulations and Policy Group, Rotorcraft Directorate, FAA, 2601 Meacham Blvd., Fort Worth, TX 76137; telephone (817) 222-5110; email sharon.y.miles@faa.gov.

SUPPLEMENTARY INFORMATION:

Comments Invited

We invite you to participate in this rulemaking by submitting written comments, data, or views. We also invite comments relating to the economic, environmental, energy, or federalism impacts that might result from adopting the proposals in this document. The most helpful comments reference a specific portion of the proposal, explain the reason for any recommended change, and include supporting data. To ensure the docket does not contain duplicate comments, commenters should send only one copy of written comments, or if comments are filed electronically, commenters should submit only one time.

We will file in the docket all comments that we receive, as well as a report summarizing each substantive public contact with FAA personnel concerning this proposed rulemaking. Before acting on this proposal, we will consider all comments we receive on or before the closing date for comments. We will consider comments filed after the comment period has closed if it is possible to do so without incurring expense or delay. We may change this proposal in light of the comments we receive.

Discussion

EASA has issued EASA AD No. 2008-0206, dated November 25, 2008, to correct the unsafe condition for the ECD Model BO 105 A, BO 105 C, BO 105 LS A-1, BO 105 D, BO 105 DS, BO 105 DB, BO 105 DBS, BO 105 DB-4, BO 105 DBS-4, BO 105 DBS-5, BO 105 S, MBB-BK 117 A-1, MBB-BK 117 A-3, MBB-BK 117 A-4, MBB-BK 117 B-1, MBB-BK 117 B-2, and MBB-BK 117 C-1 helicopters, all serial numbers. The TCCA has issued Canadian AD No. CF-2009-12, dated March 24, 2009, to correct the unsafe condition for the Eurocopter Model BO 105 LS A-3 helicopters. These ADs state that during a periodical inspection, corrosion was detected on the weights in the area of the attachment thread. Since the

issuance of the Canadian AD, the type certificate for the Model BO 105 LS A-3 has been transferred from Eurocopter Canada Limited to Eurocopter Deutschland (Germany).

The proposed actions are intended to detect corrosion and thread damage in the threaded area of a weight or lever, to prevent failure of a weight or lever, separation of tail rotor parts, severe vibration, and subsequent loss of control of the helicopter. You may obtain further information by examining the EASA and TCCA ADs and any related service information in the AD docket.

FAA's Determination

These helicopters have been approved by the aviation authority of Germany and are approved for operation in the United States. Pursuant to our bilateral agreement with Germany, EASA, its technical representative, has notified us of the unsafe condition described in its AD. We are proposing this AD because we evaluated all known relevant information and determined that an unsafe condition is likely to exist or develop on other products of the same type design.

Related Service Information

Eurocopter has issued Alert Service Bulletin (ASB) No. ASB-MBB-BK 117-30-113, dated September 23, 2008, for all MBB BK 117 model "A-1 to C-1" helicopters; ASB No. ASB BO105-30-116, dated September 23, 2008, for all Model BO105 helicopters "including BO105 CB-3 and BO105 CBS-5 KLH;" and Eurocopter Canada Limited has issued ASB No. ASB BO 105 LS 30-12, dated December 12, 2008, for Model BO 105 LS A-3 helicopters. These ASBs specify visually inspecting the weights and levers to detect corrosion or mechanical damage; corrosion at an advanced stage could destroy the threads. These ASBs also specify replacing damaged weights and levers that exceed certain limits. The actions described in the mandatory EASA and TCCA ADs are intended to correct the unsafe condition, identified in these ASBs, to ensure the continued airworthiness of these helicopters.

Proposed AD Requirements

This proposed AD would require compliance with specified portions of the manufacturer's service bulletin in conducting repetitive visual inspections of each weight and lever and would provide procedures for installing a weight or lever. Additionally, it proposes allowable tolerances for corrosion or thread damage on the threaded portion of a weight or lever and would require that a part with

corrosion or mechanical damage in excess of allowable tolerances be replaced with an airworthy part.

Differences Between This Proposed AD and the EASA and TCCA ADs

This proposed AD does not provide an extra 60 flight hours or 6 months beyond the repetitive compliance time of 600 flight hours or 48 months for the repetitive inspections. These proposals only apply to those model helicopters type-certificated in the United States.

Costs of Compliance

We estimate that this proposed AD would affect about 33 helicopters of U.S. Registry. We estimate that operators may incur the following costs in order to comply with this AD. It would take approximately 4 work-hours per helicopter to remove, inspect, and install 2 lever assemblies and 4 weights per helicopter at an average labor rate of \$85 per work-hour. Based on these figures, we estimate the inspection cost of this proposed AD would be \$340 per helicopter or \$11,220 on U.S. operators per inspection cycle. The required parts would cost about \$5,332 per helicopter. We estimate the cost for replacement would be \$5,672 per helicopter, assuming both lever assemblies and all 4 weights are replaced.

Authority for This Rulemaking

Title 49 of the United States Code specifies the FAA's authority to issue rules on aviation safety. Subtitle I, section 106, describes the authority of the FAA Administrator. "Subtitle VII: Aviation Programs," describes in more detail the scope of the Agency's authority.

We are issuing this rulemaking under the authority described in "Subtitle VII, Part A, Subpart III, Section 44701: General requirements." Under that section, Congress charges the FAA with promoting safe flight of civil aircraft in air commerce by prescribing regulations for practices, methods, and procedures the Administrator finds necessary for safety in air commerce. This regulation

is within the scope of that authority because it addresses an unsafe condition that is likely to exist or develop on products identified in this rulemaking action.

Regulatory Findings

We determined that this proposed AD would not have federalism implications under Executive Order 13132. This proposed AD would not have a substantial direct effect on the States, on the relationship between the national Government and the States, or on the distribution of power and responsibilities among the various levels of government.

For the reasons discussed, I certify this proposed regulation:

1. Is not a "significant regulatory action" under Executive Order 12866;
2. Is not a "significant rule" under the DOT Regulatory Policies and Procedures (44 FR 11034, February 26, 1979);
3. Will not affect intrastate aviation in Alaska to the extent that it justifies making a regulatory distinction; and
4. Will not have a significant economic impact, positive or negative, on a substantial number of small entities under the criteria of the Regulatory Flexibility Act.

We prepared an economic evaluation of the estimated costs to comply with this proposed AD and placed it in the AD docket.

List of Subjects in 14 CFR Part 39

Air transportation, Aircraft, Aviation safety, Incorporation by reference, Safety.

The Proposed Amendment

Accordingly, under the authority delegated to me by the Administrator, the FAA proposes to amend 14 CFR part 39 as follows:

PART 39—AIRWORTHINESS DIRECTIVES

1. The authority citation for part 39 continues to read as follows:

Authority: 49 U.S.C. 106(g), 40113, 44701.

§ 39.13 [Amended]

2. The FAA amends § 39.13 by adding the following new airworthiness directive (AD):

EUROCOPTER DEUTSCHLAND GmbH (ECD); Docket No. FAA-2012-0887; Directorate Identifier 2009-SW-02-AD.

(a) Applicability

This AD applies to Model BO-105A, BO-105C, BO-105S, and BO-105LS A-1 helicopters, with a tail rotor control lever (lever), part number (P/N) 105-317231, 105-317365, 105-31736, 105-31767, 105-31728, or 1121-31730, with tail rotor balance weight (weight) P/N 117-31715.01, 117-31715.02, 105-31728.03, 105-31732.07, or 105-31732.08; Model BO-105LS A-3 helicopters, with lever P/N 105-31736 or 105-31767, with weight P/N 117-31715.01, 117-31715.02, B642M1011 201, or 105-31717.10; and Model MBB-BK 117 A-1, MBB-BK 117 A-3, MBB-BK 117 A-4, MBB-BK 117 B-1, MBB-BK 117 B-2, and MBB-BK 117 C-1 helicopters, with lever P/N 117-31730, 117-317361, or 105-31736, with weight P/N 117-31714.07, 117-31715.01, 117-31720.01, or 117-31730.02, certificated in any category.

(b) Unsafe Condition

This AD defines the unsafe condition as corrosion or thread damage in the threaded area of a lever or weight. This condition could result in failure of a weight or lever, separation of a tail rotor part, severe tail rotor vibration, and subsequent loss of control of the helicopter.

(c) Compliance

You are responsible for performing each action required by this AD within the specified compliance time unless it has already been accomplished prior to that time.

(d) Required Actions

Within 100 hours time-in-service (TIS) or 2 months, whichever occurs first, and thereafter at intervals not to exceed 600 hours TIS or 48 months, whichever occurs first:

- (1) Remove the weights from the lever as depicted in Figure 1 to paragraph (d) of this AD. Apply marks to the weights before they are removed in order to be able to re-establish the correct assignment and the old installation position towards the lever when the weights are installed.

BILLING CODE 4910-13-P

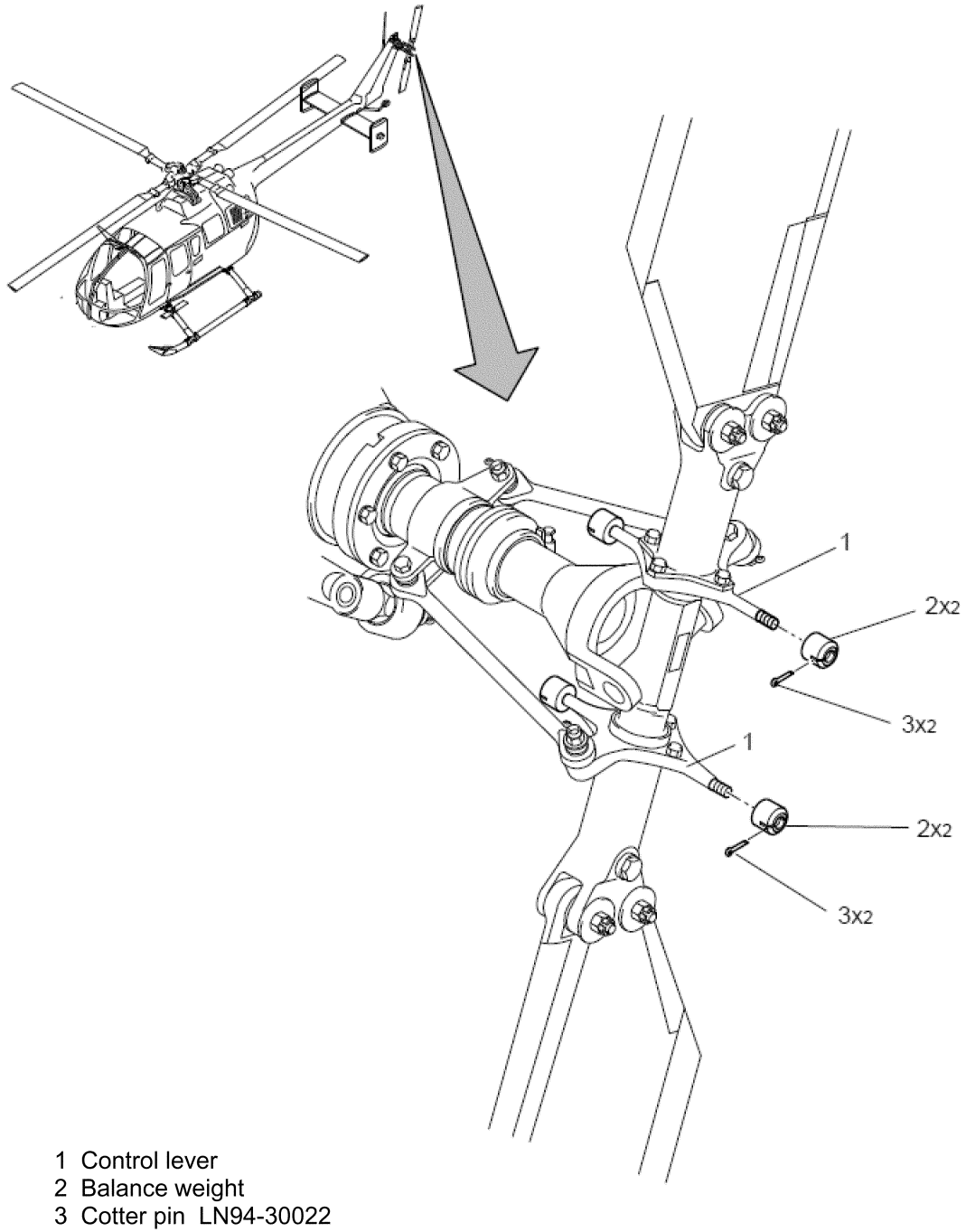

Figure 1 to paragraph (d) Tail Rotor Balance Weights

(2) Visually inspect each weight and lever for corrosion and damage in the threaded

areas as depicted in Figure 2 to paragraph (d) of this AD.

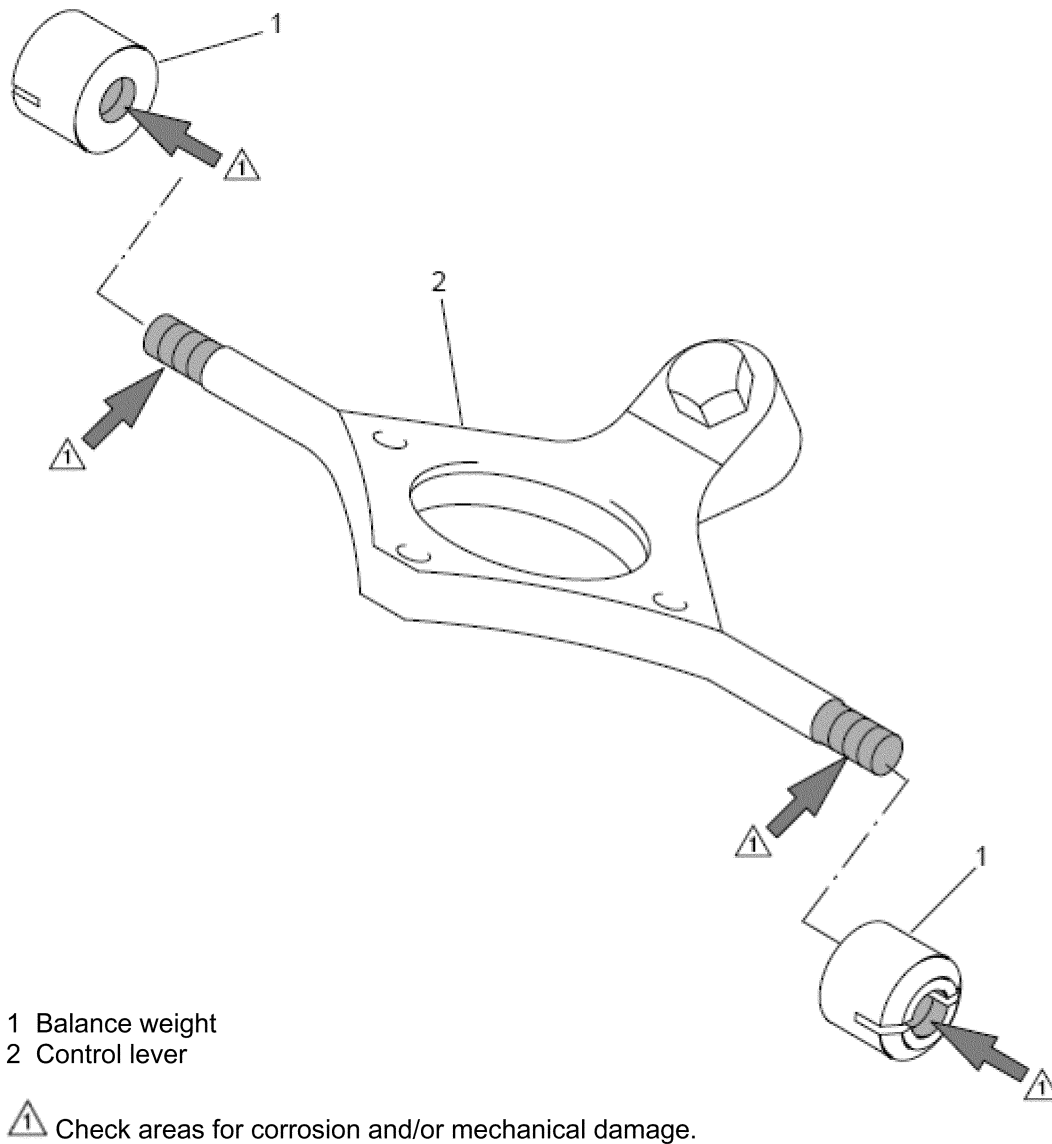

Figure 2 to paragraph (d) Inspection of Balance Weights and Control Lever

BILLING CODE 4910-13-C

(i) If there is no corrosion or thread damage on either the weight or lever, before further flight, reinstall the weight by following paragraph (d)(3) of this AD.

(ii) If there is corrosion or thread damage on the threaded portion of a *weight*:

(A) If the total area of corrosion or thread damage, or both, covers less than 25 percent of the length of the threaded area, the weight can be threaded (screwed) onto the lever, and the cylindrical mating surface has no damage, before further flight, remove the

corrosion and reinstall the weight by following paragraph (d)(3) of this AD.

(B) If the total area of corrosion or thread damage, or both, covers 25 percent or more of the length of the threaded area, the weight cannot be threaded (screwed) onto the lever, or the cylindrical mating surface has damage, before further flight, replace the weight with an airworthy weight by following paragraph (d)(3) of this AD.

(iii) If there is corrosion or thread damage on the threaded portion of the *lever*, polish out the corrosion and thread damage using a polishing cloth 600 and:

(A) If the thread depth does not exceed 0.3 millimeter (mm) and the diameter of the lever in the area before the threaded area is not less than 9.95 mm after polish out, before further flight, install airworthy weights to the lever by following paragraph (d)(3) of this AD.

(B) If the thread depth is 0.3 mm or greater or the diameter of the lever in the area before the threaded area is less than 9.95 mm after polish out, before further flight, replace the lever with an airworthy lever.

(3) Apply corrosion preventive paste onto the thread of the lever and install weights to

the lever as depicted in Figure 1 to paragraph (d) of this AD. Ensure during installation of the weights that the weights are correctly assigned and installed to the control lever in accordance with the applied marks.

(e) Alternative Methods of Compliance (AMOC)

(1) The Manager, Safety Management Group, FAA, may approve AMOCs for this AD. Send your proposal to: Sharon Miles, Aviation Safety Engineer, Regulations and Policy Group, Rotorcraft Directorate, FAA, 2601 Meacham Blvd., Fort Worth, TX 76137; telephone (817) 222-5110; email sharon.y.miles@faa.gov.

(2) For operations conducted under a 14 CFR part 119 operating certificate or under 14 CFR part 91, subpart K, we suggest that you notify your principal inspector, or lacking a principal inspector, the manager of the local flight standards district office or certificate holding district office before operating any aircraft complying with this AD through an AMOC.

(f) Additional Information

The subject of this AD is addressed in the European Aviation Safety Agency (Germany) AD No. 2008-0206, dated November 25, 2008, and in the Transport Canada Civil Aviation AD No. CF-2009-12, dated March 24, 2009.

(g) Subject

Joint Aircraft Service Component (JASC) Code: 6420, Tail Rotor Head.

Issued in Fort Worth, Texas, on August 16, 2012.

Kim Smith,

Manager, Rotorcraft Directorate, Aircraft Certification Service.

[FR Doc. 2012-21284 Filed 8-28-12; 8:45 am]

BILLING CODE 4910-13-P

DEPARTMENT OF TRANSPORTATION

Federal Aviation Administration

14 CFR Part 39

[Docket No. FAA-2012-0886; Directorate Identifier 2008-SW-067-AD]

RIN 2120-AA64

Airworthiness Directives; Agusta S.p.A. Helicopters

AGENCY: Federal Aviation Administration (FAA), DOT.

ACTION: Notice of proposed rulemaking (NPRM).

SUMMARY: We propose to adopt a new airworthiness directive (AD) for the Agusta S.p.A. (Agusta) Model AB139 and AW139 helicopters with a certain wire strike protection system (WSPS) top cable cutter assembly installed. This proposed AD is prompted by a report of in-flight contact between the top cable cutter assembly and two main rotor (M/

R) blades. This proposed AD would require reworking or replacing the top cable-cutter assembly to increase clearance between the WSPS and the M/R blades. The proposed AD actions are intended to prevent damage to the M/R blades and subsequent loss of helicopter control.

DATES: We must receive comments on this proposed AD by October 29, 2012.

ADDRESSES: You may send comments by any of the following methods:

- *Federal eRulemaking Docket:* Go to <http://www.regulations.gov>. Follow the online instructions for sending your comments electronically.
- *Fax:* 202-493-2251.
- *Mail:* Send comments to the U.S. Department of Transportation, Docket Operations, M-30, West Building Ground Floor, Room W12-140, 1200 New Jersey Avenue SE., Washington, DC 20590-0001.

• *Hand Delivery:* Deliver to the "Mail" address between 9 a.m. and 5 p.m., Monday through Friday, except Federal holidays.

Examining the AD Docket: You may examine the AD docket on the Internet at <http://www.regulations.gov> or in person at the Docket Operations Office between 9 a.m. and 5 p.m., Monday through Friday, except Federal holidays. The AD docket contains this proposed AD, the economic evaluation, any comments received, and other information. The street address for the Docket Operations Office (telephone 800-647-5527) is in the **ADDRESSES** section. Comments will be available in the AD docket shortly after receipt.

For service information identified in this proposed AD, contact Agusta, Via Giovanni Agusta, 520 21017 Cascina Costa di Samarate (VA), Italy, telephone 39 0331-229111, fax 39 0331-229605/222595, or at http://customersupport.agusta.com/technical_advice.php. You may review a copy of the referenced service information at the FAA, Office of the Regional Counsel, Southwest Region, 2601 Meacham Blvd., Room 663, Fort Worth, Texas 76137.

FOR FURTHER INFORMATION CONTACT: Sharon Miles, Aviation Safety Engineer, Regulations and Policy Group, Rotorcraft Directorate, FAA, 2601 Meacham Blvd., Fort Worth, TX 76137; telephone (817) 222-5110; email sharon.y.miles@faa.gov.

SUPPLEMENTARY INFORMATION:

Comments Invited

We invite you to participate in this rulemaking by submitting written comments, data, or views. We also invite comments relating to the

economic, environmental, energy, or federalism impacts that might result from adopting the proposals in this document. The most helpful comments reference a specific portion of the proposal, explain the reason for any recommended change, and include supporting data. To ensure the docket does not contain duplicate comments, commenters should send only one copy of written comments, or if comments are filed electronically, commenters should submit only one time.

We will file in the docket all comments that we receive, as well as a report summarizing each substantive public contact with FAA personnel concerning this proposed rulemaking. Before acting on this proposal, we will consider all comments we receive on or before the closing date for comments. We will consider comments filed after the comment period has closed if it is possible to do so without incurring expense or delay. We may change this proposal in light of the comments we receive.

Discussion

The European Aviation Safety Agency (EASA), which is the Technical Agent for the Member States of the European Union, has issued EASA AD No. 2008-0148, dated August 5, 2008, to correct the unsafe condition for these Agusta helicopters with a top cable cutter assembly, part number (P/N) 423-83001-1, which is part of the WSPS, P/N 4G9540F00211 or P/N 4G9540F00311. An incident of in-flight contact between the top cable cutter assembly and two M/R blades has been reported. Our proposed AD actions are intended to prevent damage to the M/R blades and subsequent loss of helicopter control.

FAA's Determination

These helicopters have been approved by the aviation authority of Italy and are approved for operation in the United States. Pursuant to our bilateral agreement with Italy, EASA, its technical representative, has notified us of the unsafe condition described in its AD. We are proposing this AD because we evaluated all known relevant information and determined that an unsafe condition is likely to exist or develop on other products of these same type designs.

Related Service Information

We reviewed Agusta Bollettino Tecnico No. 139-126, dated June 20, 2008 (BT), which applies to Model AB139 and AW139 helicopters with certain serial-numbered wire strike protection systems. The BT specifies, within 200 flight hours, reworking the