

3. "Guidance Document for Correcting Common VOC & Other Rule Deficiencies," EPA Region 9, August 21, 2001 (the Little Bluebook).

4. "Determination of Reasonably Available Control Technology and Best Available Retrofit Control Technology for Industrial, Institutional, and Commercial Boilers, Steam Generators, and Process Heaters," CARB, July 18, 1991.

5. "Alternative Control Techniques Document—NO_x Emissions from Industrial/Commercial/Institutional (ICI) Boilers," US EPA 453/R-94-022, March 1994.

6. "Alternative Control Techniques Document—NO_x Emissions from Utility Boilers," US EPA 452/R-93-008, March 1994.

B. Does the rule meet the evaluation criteria?

We believe this rule is consistent with the relevant policy and guidance regarding enforceability, RACT, and SIP relaxations. The TSD has more information on our evaluation.

On January 10, 2012, EPA partially approved and partially disapproved the RACT SIP submitted by California on June 18, 2009 for the SJV extreme ozone nonattainment area (2009 RACT SIP), based in part on our conclusion that the State had not fully satisfied CAA section 182 RACT requirements for solid fuel fired boiler operations. See 77 FR 1417, 1425 (January 10, 2012). Final approval of Rule 4352 would satisfy California's obligation to implement RACT under CAA section 182 for this source category for the 1-hour ozone and 1997 8-hour ozone NAAQS and thereby terminate both the sanctions clocks and the Federal Implementation Plan (FIP) clock associated with this rule.

C. EPA Recommendations To Further Improve the Rule

The TSD describes additional rule revisions that we recommend for the next time the local agency modifies the rule.

III. EPA's Proposed Action

Because EPA believes the submitted rule fulfills all applicable requirements and corrects all deficiencies identified in our October 1, 2010 action, we are proposing to fully approve it under section 110(k)(3) of the Act. We will accept comments from the public on this proposal for the next 30 days.

IV. Statutory and Executive Order Reviews

Under the Clean Air Act, the Administrator is required to approve a SIP submission that complies with the

provisions of the Act and applicable Federal regulations. 42 U.S.C. 7410(k); 40 CFR 52.02(a). Thus, in reviewing SIP submissions, EPA's role is to approve State choices, provided that they meet the criteria of the Clean Air Act. Accordingly, this proposed action merely proposes to approve State law as meeting Federal requirements and does not impose additional requirements beyond those imposed by State law. For that reason, this proposed action:

- Is not a "significant regulatory action" subject to review by the Office of Management and Budget under Executive Order 12866 (58 FR 51735, October 4, 1993);
- Does not impose an information collection burden under the provisions of the Paperwork Reduction Act (44 U.S.C. 3501 *et seq.*);
- Is certified as not having a significant economic impact on a substantial number of small entities under the Regulatory Flexibility Act (5 U.S.C. 601 *et seq.*);
- Does not contain any unfunded mandate or significantly or uniquely affect small governments, as described in the Unfunded Mandates Reform Act of 1995 (Pub. L. 104-4);
- Does not have Federalism implications as specified in Executive Order 13132 (64 FR 43255, August 10, 1999);
- Is not an economically significant regulatory action based on health or safety risks subject to Executive Order 13045 (62 FR 19885, April 23, 1997);
- Is not a significant regulatory action subject to Executive Order 13211 (66 FR 28355, May 22, 2001);
- Is not subject to requirements of Section 12(d) of the National Technology Transfer and Advancement Act of 1995 (15 U.S.C. 272 note) because application of those requirements would be inconsistent with the Clean Air Act; and
- Does not provide EPA with the discretionary authority to address disproportionate human health or environmental effects with practical, appropriate, and legally permissible methods under Executive Order 12898 (59 FR 7629, February 16, 1994).

In addition, this proposed action does not have tribal implications as specified by Executive Order 13175 (65 FR 67249, November 9, 2000), because the SIP is not approved to apply in Indian country located in the State, and EPA notes that it will not impose substantial direct costs on tribal governments or preempt tribal law.

List of Subjects in 40 CFR Part 52

Environmental protection, Air pollution control, Intergovernmental

relations, Nitrogen dioxide, Ozone, Particulate matter, Reporting and recordkeeping requirements.

Authority: 42 U.S.C. 7401 *et seq.*

Dated: April 13, 2012.

Jared Blumenfeld,

Regional Administrator, Region IX.

[FR Doc. 2012-10076 Filed 4-25-12; 8:45 am]

BILLING CODE 6560-50-P

DEPARTMENT OF TRANSPORTATION

Pipeline and Hazardous Materials Safety Administration

49 CFR Parts 105, 171, 172, 173, 177, 178, and 180

[Docket No. PHMSA-2011-0138 (HM-218G)]

RIN 2137-AE78

Hazardous Materials; Miscellaneous Amendments (RRR)

AGENCY: Pipeline and Hazardous Materials Safety Administration (PHMSA), DOT.

ACTION: Notice of proposed rulemaking (NPRM).

SUMMARY: PHMSA proposes to make miscellaneous amendments to the Hazardous Materials Regulations to update and clarify certain regulatory requirements. These proposed amendments are designed to promote safer transportation practices; eliminate unnecessary regulatory requirements; address a petition for rulemaking; incorporate a special permit into the Hazardous Materials Regulations; facilitate international commerce; and simplify the regulations. Among other provisions, PHMSA is proposing to update various entries in the Hazardous Materials Table and corresponding special provisions, clarify the lab pack requirements for temperature-controlled materials, and revise the training requirements to require that a hazardous material employer must make hazardous materials employee training records available upon request to an authorized official of the Department of Transportation (DOT) or the Department of Homeland Security (DHS).

DATES: Comments must be received by June 25, 2012.

ADDRESSES: You may submit comments by any of the following methods:

- *Federal Rulemaking Portal:* <http://www.regulations.gov>. Follow the instructions for submitting comments.
- *Fax:* 202-493-2251.
- *Mail:* Dockets Management System; U.S. Department of Transportation, Dockets Operations, M-30, Ground

Floor, Room W12-140, 1200 New Jersey Avenue SE., Washington, DC 20590-0001.

- **Hand Delivery:** To U.S. Department of Transportation, Dockets Operations, M-30, Ground Floor, Room W12-140, 1200 New Jersey Avenue SE., Washington, DC 20590-0001, between 9 a.m. and 5 p.m., Monday through Friday, except Federal holidays.

Instructions: Include the agency name and docket number PHMSA-2011-0138 (HM-218G) or rule identification number (RIN 2137-AE78) for this rulemaking at the beginning of your comment. Note that all comments received will be posted without change to <http://www.regulations.gov> including any personal information provided. If sent by mail, comments must be submitted in duplicate. Persons wishing to receive confirmation of receipt of their comments must include a self-addressed stamped postcard.

Privacy Act: Anyone is able to search the electronic form of any written communications and comments received into any of our dockets by the name of the individual submitting the document (or signing the document, if submitted on behalf of an association, business, labor union, etc.). You may review DOT's complete Privacy Act Statement in the **Federal Register** published on April 11, 2000 (65 FR 19477), or you may visit <http://www.regulations.gov>.

Docket: You may view the public docket through the Internet at <http://www.regulations.gov> or in person at the Docket Operations office at the above address (See **ADDRESSES**).

FOR FURTHER INFORMATION CONTACT: Rob Benedict, Standards and Rulemaking Division, (202) 366-8553, Pipeline and Hazardous Materials Safety Administration, U.S. Department of Transportation, 1200 New Jersey Avenue SE., Washington, DC 20590-0001.

SUPPLEMENTARY INFORMATION:

Contents

- I. Background
- II. Section-by-Section Review
- III. Regulatory Analyses and Notices
 - A. Statutory/Legal Authority for the Rulemaking
 - B. Executive Order 12866, Executive Order 13563 and DOT Regulatory Policies and Procedures
 - C. Executive Order 13132
 - D. Executive Order 13175
 - E. Regulatory Flexibility Act, Executive Order 13272, and DOT Procedures and Policies
 - F. Paperwork Reduction Act
 - G. Regulatory Identifier Number (RIN)
 - H. Unfunded Mandates Reform Act
 - I. Environmental Assessment

- J. Privacy Act
- K. International Trade Analysis

I. Background

The purpose of this NPRM is to update and clarify existing requirements by incorporating changes into the Hazardous Materials Regulations (HMR; 49 CFR parts 171-180) based on PHMSA's own initiatives. The proposed amendments were identified through an extensive review of the HMR and previously-issued letters of interpretation to the regulated hazardous materials transportation community. In addition, this NPRM proposes to incorporate a widely-held special permit with a longstanding history of safety into the HMR and respond to a petition for rulemaking. To this end, PHMSA is proposing to revise, clarify, and relax certain regulatory requirements.

Specifically, PHMSA is proposing to:

- Permit designated agents for non-residents to submit designation requests by electronic mail in addition to traditional mail.

- Add the Sulphur Institute's (TSI) "Molten Sulphur Rail Tank Car Guidance" document to the list of informational materials not requiring incorporation by reference in § 171.7 (Responds to petition for rulemaking P-1581).

- Revise the § 172.101 Hazardous Materials Table (HMT) to correct an error in the transportation requirements for entries listed under the proper shipping name, "Hydrazine Dicarboxylic Acid Diazide."

- Revise the § 172.101 HMT to remove the entry for "Zinc ethyl, see Diethylzinc" which was superseded by proper shipping names adopted in a previous rulemaking.

- Revise special provision 138 in § 172.102 to clarify the lead solubility calculation utilized for classification of material as a Marine Pollutant.

- Remove references to special provisions B72 and B74 in § 172.102. These special provisions were removed in a previous rulemaking; however, twelve entries in the § 172.101 HMT still contain references to these special provisions.

- Revise the shipping paper requirements in § 172.203(e) to permit the phrase "Residue last contained" to be placed before or after the basic shipping description sequence, or for rail shipments, directly preceding the proper shipping name in the basic shipping description sequence.

- Update the training recordkeeping requirements in § 172.704 to specify that a hazardous materials (hazmat) employer must make hazmat employee

training records available upon request, at a reasonable time and location, to an authorized official of the Department of Transportation or the Department of Homeland Security.

- Clarify that the material of trade exception in § 173.6 may be used when transporting Division 2.1 and 2.2 gases in Dewar flasks.

- Clarify the lab pack provisions in § 173.12 pertaining to temperature-controlled materials contained in a lab pack.

- Clarify the exceptions for external emergency self-closing valves on cargo tank motor vehicles (CTMVs) in § 173.33(g) to specify that external emergency self-closing valves on MC 338 cargo tanks containing cryogenic liquids may remain open during transportation.

- Correct an inadvertent deletion of the § 173.62 packaging requirements for explosives.

- Incorporate special permit DOT SP-13556 into § 173.134, to authorize the transportation by motor vehicle of certain regulated medical wastes, designated as sharps, in non-DOT specification containers fitted into wheeled racks.

- Revise the requirements for cargo air transport of alcoholic beverages § 173.150 to harmonize with the International Civil Aviation Organization's (ICAO) Technical Instructions (TI).

- Clarify the exceptions in § 173.159a for non-spillable batteries secured to skids or pallets.

- Revise § 178.2(c) to clarify the applicability of the notification requirements for packages containing residues.

- Clarify the inspection record requirements in § 180.416 for discharge systems of cargo tanks transporting liquefied compressed gases.

- Clarify the requirements for the Flame Penetration Resistance test required for chemical oxygen generators and certain compressed gases in Appendix E to Part 178.

II. Section-by-Section Review

Part 105

Section 105.40

This section provides the requirements for designated agents for non-residents. In specific instances, such as the approval of fireworks manufactured by a foreign entity, the HMR require non-residents of the United States who perform hazmat operations within the United States to designate a permanent resident of the United States to act as an agent and receive documents on behalf of the non-

resident. As specified in the HMR, non-residents of the United States must prepare a designation notification and file it with PHMSA in accordance with § 105.40.

Currently, the HMR only permits designated agent notification documents to be mailed to the Approvals and Permits Division, Pipeline and Hazardous Materials Safety Administration, Attn: PHH-30, U.S. Department of Transportation, East Building, 1200 New Jersey Avenue SE., Washington, DC 20590-0001, as specified in § 105.40(d). Revising this requirement to allow an agent designation to be transmitted by electronic mail would provide greater regulatory flexibility and align the submission of these documents with the procedures currently in place for the submission of other documents required by PHMSA.

In this NPRM, PHMSA is proposing to amend § 105.40(d) to permit agent designations to be submitted by electronic mail to the special permits or approvals office, as appropriate. The option to submit a completed agent designation to the Approvals and Permits Division by mail would remain unchanged.

Part 171

Section 171.7

The National Technology Transfer and Advancement Act of 1995 (15 U.S.C. 272) directs agencies to use voluntary consensus standards in lieu of government-unique standards except where inconsistent with law or otherwise impractical. Section 171.7 lists all standards incorporated by reference into the HMR and informational materials not requiring incorporation by reference. The informational materials not requiring incorporation by reference are noted throughout the HMR and provide best practices and additional safety measures that while not mandatory, may enhance safety and compliance.

The Sulphur Institute (TSI) represents the sulphur industry in the United States on a variety of issues including the safe transportation of sulphur in commerce. TSI submitted petition P-1581 requesting that PHMSA incorporate by reference TSI's "Molten Sulphur Tank Rail Car Guidance Document." TSI also requested that we amend § 173.24(b)(4) to add the sentence "Dried residue of molten sulfur on tank cars shall meet the 'Molten Sulphur Rail Car Guidance Document' incorporated by reference in § 171.7." TSI recognizes that molten sulphur rail tank cars with formed, solid

sulphur obscuring tank car markings, labels, and stencils can present a safety risk. Furthermore, markings and labels with diminished visibility due to molten sulphur residue present an obstacle to not only those responsible for the safe handling of these rail tank cars, but also to first responders who rely on rapid and accurate identification of a material through hazard communication markings in the event of an accident or incident. Further, the presence of an excessive amount of formed, solid sulphur on molten sulphur tank car safety appliances may also lead to decreased effectiveness of safety equipment. To address these issues, TSI has created a document entitled "Molten Sulphur Rail Tank Car Guidance" which provides best practices for the safe transport of molten sulphur in rail tank cars.

In this rulemaking, PHMSA proposes to adopt "Molten Sulphur Rail Tank Car Guidance" in the list of informational materials not requiring incorporation by reference in § 171.7(b). The inclusion of this document as reference material in the HMR should provide rail shippers of molten sulfur with a greater situational awareness of safe transport conditions for this particular commodity and reduce rail incidents for this hazardous material. In addition, PHMSA proposes to revise the entries for "Sulfur, Molten" specified in the § 172.101 HMT to reference special provision "R1" and add special provision "R1" to the R codes specified in § 172.102(c)(6). This new special provision will recommend the use of the Molten Sulphur Rail Tank Car Guidance document when transporting "Sulfur, Molten" residues by rail; however, it will not make its use mandatory. By referencing this document, we believe a greater level of safety may be achieved during the transportation of rail tanks cars which have held or currently hold molten sulfur.

Part 172

Section 172.101

This section contains the HMT and explanatory text for each of the columns in the table. In this NPRM, PHMSA is proposing a number of revisions to the § 172.101 HMT, and the special provisions specified in § 172.102 to clarify the regulations and correct inadvertent errors. Proposed changes to the § 172.101 HMT will appear as an, "add," "remove," or "revise," and include the following:

- Hydrazine dicarbonic acid diazide
- Zinc ethyl, *see* Diethylzinc
- Hydrazine dicarbonic acid diazide

- UN3469 Paint related material, flammable, corrosive (*including paint thinning or reducing compound*)
- UN2484 tert-Butyl isocyanate
- NA2927 Ethyl phosphonothioic dichloride, anhydrous
- NA2845 Ethyl phosphonous dichloride, anhydrous pyrophoric liquid
- NA2927 Ethyl phosphorodichloridate
- NA2845 Methyl phosphonous dichloride, pyrophoric liquid
- UN1831 Sulfuric acid, fuming with 30 percent or more free sulfur trioxide
- NA2448 Sulfur, molten
- UN2448 Sulfur, molten
- UN3492 Toxic by inhalation liquid, corrosive, flammable, n.o.s. with an inhalation toxicity lower than or equal to 200 ml/m³ and saturated vapor concentration greater than or equal to 500 LC50
- UN3493 Toxic by inhalation liquid, corrosive, flammable, n.o.s. with an inhalation toxicity lower than or equal to 1000 ml/m³ and saturated vapor concentration greater than or equal to 10 LC50
- UN3488 Toxic by inhalation liquid, flammable, corrosive, n.o.s. with an inhalation toxicity lower than or equal to 200 ml/m³ and saturated vapor concentration greater than or equal to 500 LC50
- UN3489 Toxic by inhalation liquid, flammable, corrosive, n.o.s. with an inhalation toxicity lower than or equal to 1000 ml/m³ and saturated vapor concentration greater than or equal to 10 LC50
- UN3490 Toxic by inhalation liquid, water-reactive, flammable, n.o.s. with an inhalation toxicity lower than or equal to 200 ml/m³ and saturated vapor concentration greater than or equal to 500 LC50
- UN3491 Toxic by inhalation liquid, water-reactive, flammable, n.o.s. with an inhalation toxicity lower than or equal to 1000 ml/m³ and saturated vapor concentration greater than or equal to 10 LC50

On January 28, 2008, PHMSA published a final rule under Docket Number PHMSA-2005-21812 (HM-218D) [73 FR 4699] entitled "Hazardous Materials; Miscellaneous Amendments." In this final rule, one of the two duplicate entries in the § 172.101 HMT for "Hydrazine, aqueous solution, with more than 37% hydrazine, by mass" was intended to be eliminated. Although one entry in the § 172.101 HMT for "Hydrazine, aqueous solution, with more than 37% hydrazine, by mass" was deleted, during the table revisions of this final rule, Columns 5 through 10 for the

entries for “Hydrazine, aqueous solution, with more than 37% Hydrazine, by mass” Packing Groups II and III were inadvertently relocated below the entry “Hydrazine dicarbonic acid diazide.” “Hydrazine dicarbonic acid diazide” should not have any entries in Columns 5 through 10 as it is forbidden for transport in the HMR. The appearance of these entries in the § 172.101 HMT is confusing and could potentially lead to the mistaken belief that “Hydrazine dicarbonic acid diazide” is not a forbidden material, but, rather authorized for transport as a Packing Group II or III material. Therefore, in this NPRM, we are proposing to remove the Packing Group II and III entries for the proper shipping name, “Hydrazine dicarbonic acid diazide” in the § 172.101 HMT.

On January 14, 2009, PHMSA published a final rule under Docket Numbers PHMSA–2007–0065 (HM–224D) and PHMSA–2008–0005 (HM–215J) [74 FR 220] entitled “Hazardous Materials: Revision to Requirements for the Transportation of Batteries and Battery-Powered Devices; and Harmonization with the United Nations Recommendations, International Maritime Dangerous Goods Code, and International Civil Aviation Organization’s Technical Instructions.” Among other revisions, PHMSA removed various specific entries for organometallic compounds and substances in the § 172.101 HMT because these entries were superseded by more appropriate generic entries. As part of these revisions, the entry for “UN1366 Diethylzinc” was removed from the § 172.101 HMT. However, the entry for “Zinc ethyl, see Diethylzinc” was inadvertently overlooked.

In this NPRM, we are proposing to remove the proper shipping name, “Zinc ethyl, see Diethylzinc” since “UN1366 Diethylzinc” is no longer listed in the § 172.101 HMT. Individuals offering “Zinc ethyl” should choose one of the more appropriate generic entries for organometallic compounds and substances added to the § 172.101 HMT under the January 14, 2009 final rule.

On January 13, 2009, PHMSA, in coordination with the Federal Railroad Administration (FRA), published a final rule under Docket Number FRA–2006–25169 [74 FR 1770], entitled “Hazardous Materials: Improving the Safety of Railroad Tank Car Transportation of Hazardous Materials.” Among other revisions, this final rule revised the HMR to improve the crashworthiness protection of railroad tank cars designed to transport poisonous inhalation hazard (PIH) materials. As part of this final rule, the

§ 172.101 HMT and special provisions specified in § 172.102 were amended to consolidate and update the special provisions applicable to the rail tank car transportation of PIH materials. The revisions to the § 172.101 HMT were for ease of reference only and did not substantively change the requirements applicable to the transportation of PIH materials by railroad tank cars. Specifically, special provisions B71, B72, and B74 were removed from the § 172.101 HMT and § 172.102, while § 172.244(a) was revised to incorporate the language from these eliminated special provisions. However, twelve additional references to special provisions B72, and B74 for selected entries in the § 172.101 HMT were not removed at the time of publication of this final rule. Therefore, in this NPRM, PHMSA proposes to make the following amendments to the Column (7) special provisions of the § 172.101 HMT:

Special provision B72 is removed from Column (7) for the following entries:

- UN2484 tert-Butyl isocyanate;
- UN3492 Toxic by inhalation liquid, corrosive, flammable, n.o.s. with an inhalation toxicity lower than or equal to 200 ml/m³ and saturated vapor concentration greater than or equal to 500 LC50;
- UN3488 Toxic by inhalation liquid, flammable, corrosive, n.o.s. with an inhalation toxicity lower than or equal to 200 ml/m³ and saturated vapor concentration greater than or equal to 500 LC50; and
- UN3490 Toxic by inhalation liquid, water-reactive, flammable, n.o.s. with an inhalation toxicity lower than or equal to 200 ml/m³ and saturated vapor concentration greater than or equal to 500 LC50.

Special provision B74 is removed from Column (7) for the following entries:

- NA2927 Ethyl phosphonothioic dichloride, anhydrous;
- NA2845 Ethyl phosphonous dichloride, anhydrous *pyrophoric liquid*;
- NA2927 Ethyl phosphorodichloridate;
- NA2845 Methyl phosphonous dichloride, *pyrophoric liquid*;
- UN1831 Sulfuric acid, fuming with 30 percent or more free sulfur trioxide;
- UN3493 Toxic by inhalation liquid, corrosive, flammable, n.o.s. with an inhalation toxicity lower than or equal to 1000 ml/m³ and saturated vapor concentration greater than or equal to 10 LC50;
- UN3489 Toxic by inhalation liquid, flammable, corrosive, n.o.s. with an inhalation toxicity lower than or equal

to 1000 ml/m³ and saturated vapor concentration greater than or equal to 10 LC50; and

UN3491 Toxic by inhalation liquid, water-reactive, flammable, n.o.s. with an inhalation toxicity lower than or equal to 1000 ml/m³ and saturated vapor concentration greater than or equal to 10 LC50.

In addition, as discussed above, PHMSA proposes to revise the entries for “Sulfur, Molten” specified in the § 172.101 HMT to reference special provision “R1.”

Section 172.102

This section contains the special provisions listed in column (7) of the § 172.101 HMT. These special provisions contain packaging provisions, prohibitions, exceptions from requirements for particular quantities or forms of materials, and requirements or prohibitions applicable to specific modes of transportation. In this NPRM, PHMSA is proposing revisions to the special provisions specified in § 172.102 to clarify the regulations and correct inadvertent errors.

As discussed above, PHMSA proposes to add special provision “R1” to the R codes specified in § 172.102(c)(6). This new special provision will reference the “Molten Sulphur Rail Tank Car Guidance” document as a resource for best practices for the cleaning of tank cars containing “Sulfur, Molten.” By referencing this document, we believe a greater level of safety can be achieved when transporting rail tanks cars which have held or currently hold molten sulfur.

In this rulemaking, we propose to revise special provision 138 to harmonize the HMR with the International Maritime Dangerous Goods (IMDG) code and to clarify that the solubility calculation provided in special provision 138 should be applied when determining when to utilize the lead compounds, soluble n.o.s. entry in the List of Marine Pollutants found in § 172.101, Appendix B.

The defining criteria for the solubility of a lead compound is specified in special provision 138 in § 172.102(c)(1). Special provision 138 specifies that a lead compound is soluble when it exhibits a solubility greater than 5 percent after being mixed with a 0.07 M (molar concentration) of hydrochloric acid and is stirred for one hour. If the material exhibits a solubility of 5 percent or less after the test is completed, it is considered insoluble and not subject to the HMR. The IMDG Code identifies “Lead compounds, soluble, n.o.s.” in Columns 4 and 6 of

the Dangerous Goods List (DGL; Chapter 3.2) as a marine pollutant, and simultaneously refers to the definition for the solubility of lead compounds under Chapter 3.3.1, special provision 199.

On March 5, 1999, the Research and Special Programs Administration (RSPA), the predecessor agency to PHMSA, published a final rule under Docket Number RSPA-98-4185 (HM-215C) [64 FR 10741], entitled "Harmonization with the United Nations Recommendations, International Maritime Dangerous Goods Code, and International Civil Aviation Organization's Technical Instructions." In HM-215C, when PHMSA incorporated the IMDG code's definition for "Lead compounds, soluble, n.o.s.," in special provision 138 into the HMR, our intent was to mirror special provision 199 of the IMDG code and to permit the definition provided in this special provision to apply to both the "lead compounds, soluble n.o.s." entry in the § 172.101 HMT and the entry in the List of marine pollutants in § 172.101, Appendix B. However, as adopted in the HMR, special provision 138 is unclear with regard to whether this criteria applies to marine pollutants.

On December 29, 2006, PHMSA published a final rule under Docket Number PHMSA-2006-25476 (HM-215I) [71 FR 78596], entitled "Harmonization with the United Nations Recommendations, International Maritime Dangerous Goods Code, and International Civil Aviation Organization's Technical Instructions." The HM-215I final rule revised the HMR to maintain alignment with international standards by incorporating various amendments, including changes to proper shipping names, hazard classes, packing groups, special provisions, packaging authorizations, air transport quantity limitations, and vessel stowage requirements. These revisions also harmonized the HMR with certain changes to the IMDG Code, the ICAO Technical Instructions, and the United Nations (UN) Recommendations. As part of the revisions in that final rule, new entries, "UN3469, Paint related material, flammable, corrosive (including paint thinning or reducing compound)," PG II, and PG III were added to the § 172.101 HMT. However, these entries were never published in subsequent versions of the HMR. Therefore, in this NPRM, we are proposing to add the entries for "Paint related material, flammable, corrosive (including paint thinning or reducing compound)" UN3469, PG II, and PG III.

Section 172.203

Section 172.202 specifies the requirements that a shipping description of a hazardous material must be indicated on a shipping paper. On December 29, 2006, PHMSA published a final rule under PHMSA-06-25476 (HM-215I) [71 FR 78595] that permitted the continued use for domestic shipments of either one of two shipping description sequences in effect in the HMR on December 31, 2006, until January 1, 2013. Specifically, the HMR authorizes the basic description of a hazardous material to consist of either the identification number first, followed by the proper shipping name, hazard class, and packing group, or as an alternative description sequence, the proper shipping name, hazard class, ID number and packing group. In addition, the basic description described above and specified in paragraphs § 172.202(a)(1)-(4) must be shown in the sequences described with no additional information interspersed. After January 1, 2013, only the basic shipping description sequence consisting of the identification number first, followed by the proper shipping name, hazard class, and packing group (in that order) is authorized.

However, § 172.203 provides allowances for a shipping paper to contain information in addition to the basic shipping description specified in § 172.202. Specifically, § 172.203(e)(1) permits that the shipping paper for a packaging containing the residue of a hazardous material may include the words "RESIDUE: LAST CONTAINED * * *" in association with the basic description of the hazardous material last contained in the packaging. Further, the shipping papers for tank cars containing the residue of a hazardous material must include the phrase, "RESIDUE: LAST CONTAINED * * *" before the basic description. While the HMR provides such a general provision, various international standards provide more specific guidance on the location of this phrase. Currently the ICAO TI, IMDG Code, and UN Model Regulations require this phrase, if used, to be placed either before or after the basic shipping description.

In this NPRM, PHMSA proposes to revise § 172.203(e)(1) to permit the shipping paper for a packaging containing the residue of a hazardous material to include the words "RESIDUE: LAST CONTAINED * * *" before or after the basic shipping description of the hazardous material last contained in the packaging. PHMSA also proposes to remove the language "in association with" and replace it

with the language "before or after" to align with various international standards. This proposed revision harmonizes the HMR with the ICAO TI, IMDG Code and UN Model Regulations.

For rail shipments of tank cars, § 172.203(e)(2) requires that the description on the shipping paper for a tank car containing the residue of a hazardous material must include the phrase, "RESIDUE: LAST CONTAINED * * *" before the basic description. Prior to the publication of the HM-215I final rule, the proper shipping name was the first piece of information required in the basic shipping description, and therefore, the phrase, "RESIDUE: LAST CONTAINED * * *" preceded the proper shipping name.

Effective January 1, 2013, rail shipments coming from Canada to the United States will be unable to comply with both the current requirements in the HMR for rail tank cars and the Transportation of Dangerous Goods (TDG) requirements. As stated above, after January 1, 2013, the proper shipping name will no longer be permitted to be the first piece of shipping information in the basic shipping description. Subsequently, the phrase, "RESIDUE: LAST CONTAINED * * *" will no longer immediately precede the proper shipping name. Furthermore the phrase, "RESIDUE: LAST CONTAINED * * *" may not be inserted into the basic description, as § 172.202(b) specifies the basic shipping description may not contain any additional information interspersed in the sequence described in § 172.202(a). Canada's TDG regulations currently permit a residue of hazardous material to be described as "Residue—Last Contained" or "Résidu—dernier contenu," followed by the shipping name of the dangerous goods last contained in the means of containment.

Therefore, in this NPRM, PHMSA proposes to revise § 172.203(e)(2) to require the description on the shipping paper for a tank car containing the residue of a hazardous material to include the phrase, "RESIDUE: LAST CONTAINED * * *" before or after the basic shipping description, or immediately preceding the proper shipping name. This change maintains the HMR's harmonization with the ICAO TI, IMDG Code and UN Model Regulations while permitting shipments transported to, from or within the United States to remain in compliance with the Canadian TDG shipping paper requirements. This revision will foster commerce between rail systems in the United States and Canada.

Section 172.704

The requirements for hazardous materials training are specified in § 172.704. This section includes a description of the applicability for hazardous materials training, the necessary components of a training program, and the recurrent training and recordkeeping requirements.

Currently, 49 CFR Part 172, Subpart I describes the requirements for security plans. Specifically, §§ 172.802(d) and 172.820(i)(1) require that a copy of the security plan must be maintained and that security plan documentation be made available upon request, at a reasonable time and location, to an authorized official of the Department of Transportation (DOT) or the Department of Homeland Security (DHS).

Similar to the security plan requirements, the training requirements include a recordkeeping component. Specifically, as specified in § 172.704(d), a record of current training, inclusive of the preceding three years, must be created and retained by each hazmat employer for as long as that employee is employed by that employer as a hazmat employee and for 90 days thereafter. However, unlike the security plan documentation, the HMR currently do not stipulate that the training records must be made available upon request to authorized officials of the DOT or DHS.

The Federal hazardous materials transportation law (Federal hazmat law, 49 U.S.C. 5101 *et seq.*) authorizes the Secretary of Transportation to prescribe regulations for the safe transportation of hazardous material in intrastate, interstate, and foreign commerce. The Secretary has delegated this authority to PHMSA. Authority to enforce the HMR has been delegated to the Federal Aviation Administration “with particular emphasis on the transportation or shipment of hazardous materials by air;” the Federal Railroad Administration “with particular emphasis on the transportation or shipment of hazardous materials by railroad;” PHMSA “with particular emphasis on the shipment of hazardous materials and the manufacture, fabrication, marking, maintenance, reconditioning, repair or test of multi-modal containers that are represented, marked, certified, or sold for use in the transportation of hazardous materials;” and the Federal Motor Carrier Safety Administration “with particular emphasis on the transportation or shipment of hazardous materials by highway” (CFR part 1, subpart C). In addition, as provided in the Homeland Security Act and as defined in a

Memorandum of Agreement between the DHS and the DOT, the United States Coast Guard retained the ability to enforce the HMR with particular emphasis on the transportation or shipment of hazardous materials by vessel. Thus, enforcement of the HMR, including the training regulations, is shared among the DOT operating administrations, United States Coast Guard and DHS, with each placing particular emphasis on their respective authorities.

Federal hazmat law, 49 U.S.C. 5121(b)(2), states that a person subject to this law shall make the records, property, reports, and information available for inspection when the Secretary undertakes an investigation or makes a request. The completion of training in accordance with Subpart H of Part 172 is essential for hazmat employees handling hazardous materials and ensures proper compliance with the HMR resulting in a greater level of safety. The recordkeeping requirements specified in § 172.704(d) allow for hazmat employers and PHMSA personnel to verify that only individuals knowledgeable in the applicable regulations are handling hazardous materials.

In an effort to foster greater compliance with the training requirements specified in Subpart H of Part 172, in this rulemaking we are proposing to revise § 172.704(d) to require that an employer must make hazmat employee training records required by Subpart H of Part 172 available upon request, at a reasonable time and location, to an authorized official of DOT or DHS.

Part 173

Section 173.6

Section 173.6 specifies the exceptions for shipments of materials of trade. A material of trade, is defined in § 171.8 as “a hazardous material, other than a hazardous waste, that is carried on a motor vehicle for the purpose of protecting the health and safety of the motor vehicle operator or passengers; for the purpose of supporting the operation or maintenance of a motor vehicle (including its auxiliary equipment); or by a private motor carrier (including vehicles operated by a rail carrier) in direct support of a principal business that is other than transportation by motor vehicle.” Section 173.6 authorizes only specific hazard classes and quantities to utilize the materials of trade exception. A hazardous material that meets the definition of a material of trade and is transported by motor vehicle in

conformance with § 173.6 is not subject to any other requirements of the HMR except for those explicitly set forth or referenced in § 173.6.

PHMSA recently received a request for a formal letter of interpretation pertaining to the application of the materials of trade exception (Reference No.: 10–0101). The letter expressed confusion and concern regarding whether the exception would apply to Division 2.1 and Division 2.2 compressed gas transported in Dewar flasks. Dewar flasks are not considered cylinders but are often used to transport Division 2.2 cryogenic liquids. Currently, § 173.6(a)(2) states that a Division 2.1 or 2.2 material in a cylinder with a gross weight not over 100 kg (220 pounds), may be transported as a material of trade provided it meets the definition of a material of trade specified in § 171.8 and all other requirements of § 173.6. As noted in PHMSA’s response to this letter, Dewar flasks are permitted to utilize the exception specified in § 173.6 provided they meet all the requirements of that section. PHMSA did not intend to limit the materials of trade exception solely to Division 2.1 or 2.2 materials packaged in cylinders.

PHMSA acknowledges that this requirement needs additional clarification, and believes that increased clarity will help to ensure the proper intended application of the materials of trade exception. Therefore, in this NPRM, we are proposing to modify § 173.6(a)(2) to clarify that Dewar flasks may be transported as materials of trade provided these materials meet all the requirements specified in § 173.6.

Section 173.12

Section 173.12 specifies the exceptions for shipment of waste materials including the requirements for waste packages known as “lab packs.” A lab pack, although not specifically defined in § 171.8, is considered a large outer packaging containing small inner packagings that are filled with various compatible laboratory hazardous wastes. In accordance with § 173.12, a lab pack is a combination packaging consisting of a glass inner packaging, not exceeding 4 L (1 gallon) rated capacity, or a metal or plastic inner packaging, not exceeding 20 L (5.3 gallons) rated capacity. Inner packagings containing liquid must be surrounded by a chemically-compatible absorbent material in sufficient quantity to absorb the total liquid contents. These inner packagings are then further packed in specification outer packaging and the completed package must not exceed a gross weight of 205 kilograms. The requirements and regulatory relief

provided for the transportation of waste hazardous materials under the lab pack exception are specified in § 173.12(b) of the HMR.

The requirements for lab packs were adopted in a final rule published under Docket Number HM-181 entitled, "Performance Oriented Packaging Standards; Changes to Classification, Hazard Communication, Packaging and Handling Requirements Based on UN Standards and Agency Initiative" and published on December 21, 1990 [55 FR 52402]. These requirements were adopted to align the HMR with regulations on lab packs issued by the Environmental Protection Agency.

The lab packing section was recently amended in a final rule published on May 14, 2010, in the **Federal Register** under Docket Number PHMSA-2009-0289 (HM-233A) [74 FR 53413] entitled, "Hazardous Materials: Incorporation of Special Permits into Regulations." As part of these amendments, certain widely-used and longstanding special permits that had an established safety record were incorporated into the HMR. Special Permit DOT SP-13192 was among these special permits, and it authorized the transport of additional hazardous materials not previously authorized for transport under § 173.12. Specifically, the incorporation of this special permit authorized the transport of waste Division 4.2, Packing Group (PG) I material and Division 5.2 (organic peroxide) material in lab packs.

PHMSA recently received a request for a formal letter of interpretation pertaining to the recent changes of the lab pack exception (Reference No.: 10-0233). The writer expressed confusion and concern regarding whether the amendments of the HM-233A final rule authorized the transportation, as lab packs, of Division 4.1 and Division 5.2 materials that were also required to be temperature-controlled. PHMSA explained that § 173.12(b) permits certain waste materials to be placed in non-specification packagings which conform to the requirements of that section. Furthermore, hazardous materials placed in lab packs are also subject to additional safety control measures designed to mitigate the risks presented by these materials, such as quantity limitations, additional packaging, and segregation requirements. However, these control measures do not eliminate the requirement that lab packs containing materials required to be temperature-controlled must also comply with temperature-control requirements specified in § 173.21(f)(1).

PHMSA acknowledges that this requirement needs additional

clarification, and believes that increased clarity will help to ensure that individuals transporting lab packs containing temperature-controlled materials are aware that such packagings are not excepted from other safety measures. Therefore, in this NPRM, we are proposing to modify § 173.12 to clarify that temperature-controlled materials may be transported in lab packs provided these materials also meet the requirements in § 173.21(f)(1).

Section 173.33

Section 173.33 provides the requirements for hazardous materials transported in Cargo Tank Motor Vehicles (CTMVs). This section includes general requirements for CTMVs, as well as more specific requirements for loading, maximum lading pressure, relief systems, and closing valves.

Section 173.33(g) requires each liquid filling and liquid discharge line in a specification MC 338 cargo tank must be provided with a remotely-controlled internal self-closing stop valve except when the MC 338 cargo tank is used to transport argon, carbon dioxide, helium, krypton, neon, nitrogen, and xenon.

The discharge control device requirements for a MC 338 cargo tank are found in § 178.338-11(b) and state that each liquid filling and liquid discharge line must be provided with a shut-off valve located as close to the tank as practicable and, unless the valve is manually operable at the valve, the line must also have a manual shut-off valve.

PHMSA received a request for a formal letter of interpretation regarding the current requirements for MC 338 cargo tanks (Reference No.: 06-0243). According to the request, most vacuum insulated MC 338 cargo tanks operate at temperatures below the reliable operating temperature of available internal self-closing stop valves, and currently no manufacturer builds an internal self-closing stop valve that will operate reliably at temperatures that may reach minus 452 °F. The requestor asked if a MC 338 cargo tank is required to have a remotely-controlled internal self-closing stop valve as specified in § 173.33(g), provided an external stop valve is present in accordance with § 178.338-11(b).

PHMSA does not intend to require a remotely-controlled internal self-closing stop valve if the MC 338 cargo tank already utilizes an external self-closing stop valve to meet the requirements in § 178.338-11(b). Therefore, in this rulemaking, we are proposing to revise

the provisions in § 173.33(g) to clarify this exception.

Section 173.62

Section 173.62 specifies packaging requirements for explosives. Specifically, § 173.62 provides a table that specifies the packaging instructions, and corresponding authorized inner, intermediate and outer packagings based on the assigned identification number of the explosive.

In a final rule published on September 13, 2011, under Docket Number PHMSA-2011-0134 (HM-244D) [76 FR 56304], entitled "Minor Editorial Corrections and Clarifications," PHMSA revised § 173.63(c)(5) packaging instruction 130 to authorize the use of aluminum boxes (4B) and natural wood, sift-proof walls boxes (4C2). However, the following language was inadvertently removed from the first column of the packing instruction:

2. Subject to approval by the Associate Administrator, large explosive articles, as part of their operational safety and suitability tests, subjected to testing that meets the intentions of Test Series 4 of the UN Manual of Tests and Criteria with successful test results, may be offered for transportation in accordance with the requirements of this subchapter."

PHMSA did not intend to remove this portion of the packaging instruction and unnecessarily limit the transport of large explosive articles. Therefore, in this NPRM, PHMSA is proposing to revise § 173.63(c)(5) packing instruction 130 to reinstate the language inadvertently removed from the first column of packing instruction 130.

Section 173.134

Section 173.134 provides definitions and exceptions for infectious substances. Paragraph (c)(2) of this section requires a Regulated Medical Waste (RMW) that contains Category B cultures and stocks to be transported on a vehicle "used exclusively" to transport RMW. A Category B substance is defined as "an infectious substance that is not in a form generally capable of causing permanent disability or life-threatening or fatal disease in otherwise healthy humans or animals when exposure to it occurs."

As amended on July 20, 2011, in a final rule published under Docket Number PHMSA-2009-0151 (HM-218F) [76 FR 43510], entitled "Miscellaneous Amendments," PHMSA revised § 173.134(c)(2) to incorporate the clarifications from a March 19, 2007 letter of interpretation (Ref. No. 07-0057). Specifically, PHMSA specified that the following materials may be

transported on a vehicle used exclusively to transport RMW: (1) Plant and animal waste regulated by the Animal and Plant Health Inspection Service (APHIS); (2) waste pharmaceutical materials; (3) laboratory and recyclable wastes; (4) infectious substances that have been treated to eliminate or neutralize pathogens; (5) forensic materials being transported for final destruction; (6) rejected or recalled health care products; and (7) documents intended for destruction in accordance with Health Insurance Portability and Accountability Act of 1996 (HIPAA) requirements.

In response to the proposals in the HM-218F Notice of Proposed Rulemaking, Stericycle commented that the rationale underlying PHMSA's decision to authorize the transportation of multiple waste streams from medical facilities should also apply to other regulated activities, specifically to those covered under special permit DOT SP-13556, which authorizes the transportation of sharps in specialized containers. At the time of the July 20, 2011 final rule, PHMSA determined that incorporating special permit DOT SP-13556 into the HMR was beyond the scope of that rulemaking, but this issue would be addressed in a future NPRM. We are addressing the issue in this rulemaking. Therefore, in this NPRM, PHMSA is proposing to revise § 173.134(c)(2) to incorporate special permit DOT SP-13556 relating to the transport of regulated medical waste into the HMR.

Specifically, PHMSA is proposing to add the phrase "sharps containers containing sharps" to § 173.134(c)(2) to permit certain materials to be transported on a vehicle used exclusively to transport RMW. PHMSA is also proposing to include certain operational controls for shipments of sharps containers that are detailed in special permit DOT SP-13556.

Section 173.150

Section 173.150 provides exceptions from the HMR for certain Class 3 flammable liquid material. Specifically, § 173.150(d) provides exceptions for alcoholic beverages for all modes of transport. An alcoholic beverage (as defined in 27 CFR §§ 4.10 and 5.11) that meets one of three conditions specified

in § 173.150(d) is not subject to the requirements of the HMR for a Class 3 flammable liquid material.

Currently, the ICAO Technical Instructions (TI) provide exceptions for alcoholic beverages transported via aircraft in Chapter 3; 3.1.1, Table 3-2, special provision A9 and Chapter 8; 8.1.2 paragraph (l). Specifically, Chapter 3; 3.1.1 states that alcoholic beverages containing not more than 70 percent alcohol by volume, when packaged in receptacles of 5 liters or less are not subject to the ICAO TI when carried by cargo aircraft. In addition, as specified in Chapter 8; 1.1.2 paragraph (l) of the ICAO TI, alcohol beverages with less than 24 percent alcohol by volume or alcohol beverages in retail packaging and alcoholic beverages containing more than 24 percent but not more than 70 percent alcohol by volume in receptacles not exceeding 5 liters are permitted to be carried by passengers or crew in carry-on or checked luggage and are not otherwise subject to the ICAO TI.

Generally, the HMR is harmonized with the ICAO TI with regard to the exceptions provided for alcoholic beverages shipped by passenger carrying and cargo aircraft. However, for cargo aircraft, the HMR does not align with the ICAO TI. For example, as specified in § 173.150(d), the HMR excepts alcoholic beverages in an inner packaging of 5 L (1.3 gallons) or less from regulation regardless of the alcohol percent on cargo aircraft. In contrast, the ICAO TI limits this exception to alcoholic beverages not exceeding 70 percent alcohol by volume. This lack of harmonization can lead to frustration of shipments of these types of materials in international air transport.

Therefore, in this NPRM, we propose to revise the exceptions in § 173.150(d) to harmonize the alcoholic beverages exception via aircraft with the requirements in the ICAO TI and to restructure the exceptions in § 173.150(d) to provide clarity on the requirements for the transport of alcoholic beverages by each mode of transport including passenger carrying and cargo aircraft. Specifically, PHMSA proposes to revise § 173.150(d) by separating the requirements for alcoholic beverages into two subparagraphs: one paragraph

pertaining to the transport of alcoholic beverages via motor vehicle, rail, and vessel; and one paragraph pertaining to the transport of alcoholic beverages via air transport. We believe that separating the requirements for alcoholic beverages by mode promotes clarity and allows for the current requirements to remain in effect for motor vehicle, rail and vessel transport while fully harmonizing the air requirements in the HMR with the ICAO TI.

PHMSA proposes to harmonize with the ICAO technical instructions by stipulating that for transport via cargo aircraft, in addition to the current 5 liter limitation in the HMR, the alcohol beverage must not exceed 70 percent alcohol by volume. In addition, we propose to move the requirements for the transport of alcoholic beverages by passenger carrying aircraft by passengers and crew into a standalone sub-subparagraph to improve clarity.

A cost may be incurred by the alcoholic beverage industry for certain high alcohol content (70 percent and up) beverages shipped by cargo aircraft which are currently excepted from the requirements of the HMR. However, PHMSA anticipates this cost to the alcoholic beverage industry will be minimized by three factors. First, due to the non-perishable nature of alcoholic beverages, the vast majority of alcoholic beverages are transported by ground transport or, if required to be exported, by vessel transport. Second, the majority of alcohols and distilled spirits manufactured and transported have a percentage of alcoholic content of, at, or below 40 percent (80 proof). Thus the proposed change would affect only a small segment of high alcohol content liquors. Lastly, in the rare instances these beverages are shipped by air, many air carriers already require compliance with ICAO TI, thus the impact of this harmonization should be minimal. The derived benefit from this revision would be realized from increased harmonization with the ICAO TI and greater hazard communication and packaging standards on high content alcoholic beverages which pose a risk in transport. A summary of the proposed revisions to the requirements for alcoholic beverages can be seen in the table below.

| | Current HMR alcohol beverage exceptions | Current ICAO TI alcohol beverage exceptions | Proposed HMR change |
|---------------|--|---|---------------------------------------|
| Highway | (1) Contains 24 percent or less alcohol by volume. (2) Is in an inner packaging of 5 L (1.3 gallons) or less. | N/A | No change. Restructure the paragraph. |

| | Current HMR alcohol beverage exceptions | Current ICAO TI alcohol beverage exceptions | Proposed HMR change |
|--------------------|--|--|--|
| Rail | (3) Is a Packing Group III alcoholic beverage in a packaging of 250 L (66 gallons) or less. (1) Contains 24 percent or less alcohol by volume. (2) Is in an inner packaging of 5 L (1.3 gallons) or less. | N/A | No change. Restructure the paragraph. |
| Vessel | (3) Is a Packing Group III alcoholic beverage in a packaging of 250 L (66 gallons) or less. (1) Contains 24 percent or less alcohol by volume. (2) Is in an inner packaging of 5 L (1.3 gallons) or less. | N/A | No change. Restructure the paragraph. |
| Passenger Air | (1) Contains 24 percent or less alcohol by volume. (2) More than 24 percent and not more than 70 percent alcohol by volume when in unopened retail packagings not exceeding 5 liters (1.3 gallons) carried in carry-on or checked baggage, with a total net quantity per person of 5 liters (1.3) gallons for such beverages. | (1) Contains 24 percent or less alcohol by volume. (2) More than 24 percent and not more than 70 percent alcohol by volume when in unopened retail packagings not exceeding 5 liters (1.3 gallons) carried in carry-on or checked baggage, with a total net quantity per person of 5 liters (1.3) gallons for such beverages. | No change. Restructure the paragraph. |
| Cargo Air | (1) Contains 24 percent or less alcohol by volume. (2) Is in an inner packaging of 5 L (1.3 gallons) or less. | (1) Contains 24 percent or less alcohol by volume. (2) Alcoholic beverages not exceeding 70 percent alcohol content by volume when packaged in 5 liters or less. | An upper limit of 70 percent alcohol by volume is proposed to be added to alcoholic beverages shipped by cargo aircraft to harmonize with the ICAO requirements. |

Section 173.159a

Section 173.159 specifies requirements for the transportation of wet batteries, including non-spillable batteries. Further exceptions for non-spillable batteries are specified in § 173.159a. If certain transport conditions specified in §§ 173.159 and 173.159a are met, such as specific packaging and securement requirements, non-spillable batteries are excepted from the HMR.

In a final rule published on January 14, 2009, under Docket Nos. PHMSA–2007–0065 (HM–224D) and PHMSA–2008–0005 (HM–215J) [74 FR 2200], entitled “Hazardous Materials: Revision to Requirements for the Transportation of Batteries and Battery-Powered Devices; and Harmonization With the United Nations Recommendations, International Maritime Dangerous Goods Code, and International Civil Aviation Organization’s Technical Instructions,” PHMSA amended § 173.159(f) to describe the conditions under which a battery is considered “non-spillable,” and relocated the exceptions pertaining to non-spillable batteries from §§ 173.159(d) and 173.159(f), to a new § 173.159a.

However, when these exceptions were relocated, PHMSA inadvertently required that excepted non-spillable

batteries must be securely packaged in strong outer packagings. This modification, in essence, prohibited excepted batteries from being palletized or placed on a skid. Therefore, in this NPRM, PHMSA is proposing to revise § 173.159a(c)(1) to except from the packaging requirements of § 173.159, non-spillable batteries that are secured to skids or pallets and capable of withstanding the shocks normally incident to transportation, provided the batteries meet the requirements of § 173.159(a) and are loaded or braced so as to prevent damage and short circuits in transit. Further, any other material loaded in the same vehicle must be blocked, braced, or otherwise secured to prevent contact with or damage to the batteries.

Part 177

Section 177.834

Section 177.834 provides the general requirements for the loading and unloading of vehicles intended to transport hazardous materials via ground transportation. Paragraph (j) of this section requires CTMVs to be transported with all valves and other closures in liquid discharge systems to be closed and free of leaks unless transported in accordance with the

requirements for empty packages specified in § 173.29(b)(2).

The provision specified in § 177.834(j) was added on May 30, 1996, in a final rule published under Docket Number HM–222B [61 FR 27166] to consolidate the closure requirements for cargo tanks transporting Class 3 (flammable liquid) materials, Class 8 (corrosive) materials, and Division 6.1 (poisonous) materials. This rule inadvertently overlooked the impact the closure requirement would have on MC 338 cargo tanks that transport cryogenic liquids. These tanks have external self-closing valves that are normally transported in an open position and are designed to close with a tremendous amount of force to ensure proper closure. Subsequently, these valves require a large amount of force and effort to open. As a result, the potential for physical injury to employee personnel is increased and the ability of the valve system to operate is potentially compromised as a result of repeated cycling (opening, closing, and testing).

Therefore, in this NPRM, we propose to revise § 177.834(j) to permit external emergency self-closing valves on MC 338 cargo tanks containing residues of cryogenic liquids to remain either open or closed during transit.

Part 178

Section 178.2

Section 178.2 specifies the responsibilities of the manufacturer or other person certifying compliance with the specification packaging requirements of Part 178. As part of these requirements, the manufacturer or other person certifying compliance with the requirements of Part 178 must provide both notification to each person to whom a packaging is transferred of all requirements in Part 178 not met at the time of transfer, and closure requirements for the packaging. These closure requirements include information specifying the type(s) and dimensions of the closures, including gaskets and any other components needed to ensure that the packaging is capable of successfully passing the applicable performance tests. This information must include any procedures to be followed, including closure instructions for inner packagings and receptacles, to effectively assemble and close the packaging for the purpose of preventing leakage in transportation. Closure instructions must provide for a consistent and repeatable means of closure that is sufficient to ensure the packaging is closed in the same manner as it was tested.

A package, as defined in § 171.8, “means a packaging plus its contents.” Ensuring that a package is closed in a manner which precludes the release of a hazardous material is essential to safe transportation, regardless of whether the package is completely filled or contains only residue. In accordance with § 173.29, an empty packaging containing only the residue of a hazardous material must be offered for transportation and transported in the same manner as when it previously contained a greater quantity of that hazardous material. This includes properly closing the packaging for transportation and providing closure notification requirements to each person whom a packaging is transferred in accordance with § 178.2(c).

In April 2006, PHMSA received a request (Reference No.: 06–0123) seeking clarification of the closure notification requirements specified in § 178.2(c) for packages containing residues. In response, we indicated that packages containing residues must meet the notification requirements of § 178.2(c) and that we would clarify this issue in a future rulemaking.

In this rulemaking, PHMSA is addressing this issue by proposing to revise § 178.2(c) to clarify that the notification requirements apply to

packagings containing a residue of a hazardous materials unless these packagings of hazardous materials meet the exceptions provided in § 173.29(b). This clarification will ensure packages containing residues are properly closed and increase compliance with the intent of this regulation. This increased compliance should also result in fewer packages being improperly closed, and thereby reduce the potential for leaks in transportation.

Certain CTMVs require as part of their specification both a CTMV manufacturer’s data report and a certificate stating that the completed cargo tank motor vehicle conforms in all respects to the appropriate specification and the American Society of Mechanical Engineers (ASME) Code. Section 178.2(c) currently excepts CTMVs which require a manufacturer’s data report and certificate from the notification requirements. Specifically, § 178.2(c) states that CTMV’s in compliance with §§ 178.337–18 and 178.345–10 are excepted from the notification requirements specified in § 178.2(c). The current reference to § 178.345–10 in paragraph § 178.2 (c) refers to pressure relief, not the CTMV manufacturer’s data report and certificates for DOT 406, 407 and 412 (CTMVs), and is in error. The correct citation should read § 178.345–15, which refers to the manufacturer’s data report and certification of DOT 406, 407 and 412 CTMVs. In addition, it was brought to PHMSA’s attention that a reference to a MC 338 cargo tank manufacturer’s data report certificate in § 178.338–19 is missing in § 178.2(c).

We agree and believe that a reference to a MC 338 cargo tank manufacturer’s data report certificate would be appropriate in § 178.2(c). Therefore, in this rulemaking, we propose to correct these errors and omissions by replacing the reference to § 178.345–10 with § 178.345–15 and adding a reference to § 178.338–19.

Appendix E to Part 178

Appendix E to Part 178 describes the Flame Penetration Resistance Test referenced throughout the HMR with regard to the outer packaging for chemical oxygen generators and cylinders containing compressed oxygen. This appendix specifies requirements for the Flame Penetration Resistance Test and includes criteria for acceptance of a passing test result, a summary of the test method and procedure, details on the preparation of test specimens, and construction and calibration specifications for the test equipment.

On January 31, 2007, PHMSA published a final rule under docket number RSPA–04–17664 (HM–224B) [72 FR 4442] entitled “Transportation of Compressed Oxygen, Other Oxidizing Gases and Chemical Oxygen Generators on Aircraft,” which included amendments that changed packaging and marking requirements for air shipments of compressed oxygen cylinders and chemical oxygen generators. As of October 1, 2009, certain compressed gases shipped by air, and chemical oxygen generators must be placed in a rigid outer packaging demonstrated to withstand both flame penetration and thermal resistance testing requirements.

Appendix E specifies the procedures to follow to conduct the Flame Penetration Resistance Test. The test procedure is described in sections (g)(2) of this Appendix and references a “Figure 1,” but HMR, Figure 1 is omitted. In sections (d)(3) and (f)(2) of this Appendix, the design and calibration of the calorimeter is described and refers to a “Figure 2,” but Figure 2 is also omitted. Therefore, in this NPRM, PHMSA is proposing to add Figures 1 and 2 that were referenced but inadvertently omitted from Appendix E.

Part 180

Section 180.416

Section 180.416 details the requirements for a discharge system inspection and maintenance program for cargo tanks transporting liquefied compressed gases. Specifically, § 180.416 applies to operators using specification MC 330, MC 331, and non-specification cargo tanks authorized under § 173.315(k) for transportation of liquefied compressed gases other than carbon dioxide. As part of the discharge system inspection specified in this section, the operator must visually inspect each delivery hose assembly at least once each calendar month in which the delivery hose assembly is in service and keep a record of each inspection. In accordance with § 180.416(d), that record must include the inspection date, the name of the person performing the inspection, the hose assembly identification number, the company name, the date the hose was assembled and tested, and an indication that the delivery hose assembly and piping system passed or failed the tests and inspections.

There has been some confusion among the regulated community pertaining to the requirement to include “the company name” in the record as specified in § 180.416(d). Specifically, there was concern over whether “the

company name” refers to the name of the operator or the name of the manufacturer of the hose.

In this NPRM, PHMSA proposes to revise § 180.416(d) to clarify that the reference to the “company name” on the inspection record is the name of the hose manufacturer. We believe this proposed revision will clarify the requirement for discharge system inspection records, resulting in more accurate records for specification MC 330, MC 331, and non-specification cargo tanks authorized under § 173.315(k) transporting of liquefied compressed gases other than carbon dioxide.

III. Regulatory Analyses and Notices

A. Statutory/Legal Authority for This Rulemaking

This NPRM is published under authority of Federal hazardous materials transportation law (Federal hazmat law; 49 U.S.C. 5101 et seq.). Section 5103(b) of Federal hazmat law authorizes the Secretary of Transportation to prescribe regulations for the safe transportation, including security, of hazardous materials in intrastate, interstate, and foreign commerce. If adopted as proposed, this NPRM would make miscellaneous amendments to the HMR. In addition, if adopted as proposed, this NPRM would correct errors in the hazardous materials table and corresponding special provisions, clarify the requirements for lab packing temperature controlled materials and clarify various cargo tank provisions and revise the training requirements to require that a hazmat employer must make hazmat employee training records available upon request to an authorized official. These amendments clarify regulatory requirements and, where appropriate, decrease the regulatory burden without compromising the safe transportation of hazardous materials in commerce.

B. Executive Order 12866, Executive Order 13563 and DOT Regulatory Policies and Procedures

This proposed rule is not considered a significant regulatory action under section 3(f) and was not reviewed by the Office of Management and Budget (OMB). The proposed rule is not considered a significant rule under the Regulatory Policies and Procedures order issued by the Department of Transportation [44 FR 11034].

In this notice of proposed rulemaking, we propose to amend miscellaneous provisions in the HMR to clarify the provisions and to relax overly burdensome requirements. PHMSA

anticipates the proposals contained in this rule will have economic benefits to the regulated community. This NPRM is designed to increase the clarity of the HMR, thereby increasing voluntary compliance while reducing compliance costs.

Executive Order 13563 is supplemental to and reaffirms the principles, structures, and definitions governing regulatory review that were established in Executive Order 12866 Regulatory Planning and Review of September 30, 1993. In addition, Executive Order 13563 specifically requires agencies to: (1) Involve the public in the regulatory process; (2) promote simplification and harmonization through interagency coordination; (3) identify and consider regulatory approaches that reduce burden and maintain flexibility; (4) ensure the objectivity of any scientific or technological information used to support regulatory action; and (5) consider how to best promote retrospective analysis to modify, streamline, expand, or repeal existing rules that are outmoded, ineffective, insufficient, or excessively burdensome.

In this NPRM, PHMSA has involved the public in the regulatory process in a variety of ways. Specifically, in this rulemaking PHMSA is addressing issues and errors that were identified and tagged for future rulemaking consideration in letters of interpretation issued to the regulated community and through other correspondence with PHMSA stakeholders. In addition, PHMSA has responded to the TSI’s request to incorporate a guidance document designed to assist the sulphur industry in ensuring the safe transport of molten sulphur (P–1581). PHMSA is asking for public comments based on the proposals in this NPRM. Upon receipt of public comment, PHMSA will address all substantive comments in the next rulemaking action under this docket number.

The amendments in the NPRM promote simplification and harmonization through interagency coordination. Specifically, in this NPRM, PHMSA is simplifying the lab packing requirements, the hazardous materials table and special provisions and the requirements for cargo tank transportation. These revisions are expected to produce a safety benefit derived from the increased clarity and reduced ambiguity in the special provisions to the § 172.101 HMT, and the lab packaging and cargo tank requirements of the HMR. There are minimal additional costs. The clarity will result in net benefits.

This NPRM also promotes harmonization with international standards, such as the IMDG Code, Canada’s TDG requirements and the ICAO TI with regard to the handling of “Lead compounds, soluble n.o.s.” via vessel, rail shipments of residue between the United States and Canada and alcoholic beverages via aircraft.

These revisions to the § 172.101 HMT will eliminate errors in the § 172.101 HMT, reduce ambiguity, harmonize the HMR with international regulations, and improve clarity. Many of these revisions were brought to PHMSA’s attention through letters of interpretation requested from the regulated community. Although these revisions are minor, they are expected to produce a safety benefit derived from the increased clarity and accuracy of the text in the § 172.101 HMT.

This NPRM proposes approaches that reduce the regulatory burden on the regulated community, allows for flexibility in achieving compliance and maintains an appropriate level of safety. This NPRM permits flexibility in achieving compliance when transporting cargo tanks while maintaining an appropriate level of safety. This NPRM also incorporates a special permit DOT SP–13556 that has a strong record of safety. Incorporating this permit into the HMR will provide wider access to the benefits of the provisions granted in this special permit, therefore, fostering greater regulatory flexibility without compromising transportation safety.

A majority of the amendments in this rulemaking are simple clarifications and do not require significant scientific or technological information. However, when necessary in this NPRM, PHMSA used scientific or technological information to support its regulatory action. Specifically, such data was considered when structuring alternatives on how to best deal with issues regarding the safe transport of cargo tanks and the transport of alcoholic beverages with greater than 70 percent alcohol by volume via cargo aircraft. This information was used in the evaluation of alternative proposals and ultimately this information determined how best to promote retrospective analysis to modify and streamline existing requirements that are outmoded, ineffective, insufficient, or excessively burdensome.

C. Executive Order 13132

This proposed rule was analyzed in accordance with the principles and criteria contained in Executive Order 13132 (“Federalism”). This proposed rule would preempt state, local and

Indian tribe requirements but does not propose any regulation that has substantial direct effects on the states, the relationship between the national government and the states, or the distribution of power and responsibilities among the various levels of government. Therefore, the consultation and funding requirements of Executive Order 13132 do not apply.

The Federal hazardous material transportation law, 49 U.S.C. 5125(b)(1), contains an express preemption provision (49 U.S.C. 5125(b)) preempting state, local, and Indian tribe requirements on certain covered subjects. Covered subjects are:

- (i) The designation, description, and classification of hazardous materials;
- (ii) The packing, repacking, handling, labeling, marking, and placarding of hazardous materials;
- (iii) The preparation, execution, and use of shipping documents related to hazardous materials and requirements related to the number, content, and placement of those documents;
- (iv) The written notification, recording, and reporting of the unintentional release in transportation of hazardous materials; or
- (v) The design, manufacture, fabrication, marking, maintenance, reconditioning, repair, or testing of a packaging or container which is represented, marked, certified, or sold as qualified for use in the transport of hazardous materials.

This proposed rule concerns the classification, packaging, and handling of hazardous materials, among other covered subjects. If adopted, this rule would preempt any state, local, or Indian tribe requirements concerning these subjects unless the non-Federal requirements are “substantively the same” (see 49 CFR 107.202(d) as the Federal requirements.)

Federal hazardous materials transportation law provides at 49 U.S.C. 5125(b)(2) that if PHMSA issues a regulation concerning any of the covered subjects, PHMSA must determine and publish in the **Federal Register** the effective date of Federal preemption. That effective date may not be earlier than the 90th day following the date of issuance of the final rule and not later than two years after the date of issuance. PHMSA proposes the effective date of federal preemption be 90 days from publication of a final rule in this matter in the **Federal Register**.

D. Executive Order 13175

This proposed rule has been analyzed in accordance with the principles and criteria contained in Executive Order 13175 (“Consultation and Coordination

with Indian Tribal Governments”). Because this proposed rule does not have tribal implications and does not impose substantial direct compliance costs on Indian tribal governments, the funding and consultation requirements of Executive Order 13175 do not apply, and a tribal summary impact statement is not required.

E. Regulatory Flexibility Act, Executive Order 13272, and DOT Procedures and Policies

The Regulatory Flexibility Act (5 U.S.C. 601 *et seq.*) requires an agency to review regulations to assess their impact on small entities unless the agency determines the rule is not expected to have a significant impact on a substantial number of small entities. This proposed rule would amend miscellaneous provisions in the HMR to clarify provisions based on our PHMSA’s initiatives and correspondence with the regulated community. While maintaining safety, it would relax certain requirements that are overly burdensome. The proposed changes are generally intended to provide relief to shippers, carriers, and packaging manufacturers, including small entities.

Consideration of alternative proposals for small businesses. The Regulatory Flexibility Act directs agencies to establish exceptions and differing compliance standards for small businesses, where it is possible to do so and still meet the objectives of applicable regulatory statutes. In the case of hazardous materials transportation, it is not possible to establish exceptions or differing standards and still accomplish our safety objectives.

The impact of this proposed rule is not expected to be significant. The proposed changes are generally intended to provide relief to shippers, carriers, and packaging manufacturers and testers, including small entities. This relief will provide marginal positive economic benefits to shippers, carriers, and packaging manufacturers and testers, including small entities however; these benefits are not at a level that can be considered economically significant. Therefore, this proposed rule will not have a significant economic impact on a substantial number of small entities.

This proposed rule has been developed in accordance with Executive Order 13272 (“Proper Consideration of Small Entities in Agency Rulemaking”) and DOT’s procedures and policies to promote compliance with the Regulatory Flexibility Act to ensure that

potential impacts of draft rules on small entities are properly considered.

F. Paperwork Reduction Act

This proposed rule does not impose any new information collection requirements and in three instances marginally decreases the information collection burden on the reregulated community. Specifically the following information collections affected by this rulemaking are:

- Office of Management and Budget (OMB) Control Number 2137–0051; Rulemaking and Special Permit Petitions: A slight reduction in information collection burden is anticipated due to the incorporation of a DOT SP–13556 into § 173.134. This permit will allow individuals more flexibility when transporting sharps and decrease the need for special permits applications when transporting sharps as regulated medical wastes.
- OMB Control Number 2137–0034; Hazardous Materials Shipping Papers and Emergency Response Information: A negligible reduction in information collection burden due to relaxation of the shipping paper description requirements for residues specified in § 172.203. Specifically, this will allow individuals more flexibility on the shipping paper descriptions when shipping waste internationally, and will correct a regulatory inconsistency between the HMR and Canadian Hazardous materials regulations, fostering international transport of residues.

- OMB Control Number 2137–0557; Approvals for Hazardous Materials: A slight reduction in information collection burden is anticipated due to relaxation of approval submittal requirements specified in § 105.40. Specifically, this relaxation will permit individuals wishing to apply with PHMSA to be an approved designated agent to submit their applications either by standard mail or electronic mail. Currently, the HMR only permits submission through standard mail. This change will result in a decrease in duplicate hard copies submitted to PHMSA as well as a decrease in the processing time for such applications.

G. Regulation Identifier Number (RIN)

A regulation identifier number (RIN) is assigned to each regulatory action listed in the Unified Agenda of Federal Regulations. The Regulatory Information Service Center publishes the Unified Agenda in April and October of each year. The RIN number contained in the heading of this document can be used to cross-reference this action with the Unified Agenda.

H. Unfunded Mandates Reform Act

This proposed rule does not impose unfunded mandates under the Unfunded Mandates Reform Act of 1995. It does not result in costs of \$141,300,000 or more to either state, local, or tribal governments, in the aggregate, or to the private sector, and is the least burdensome alternative that achieves the objective of the rule.

I. Environmental Assessment

The National Environmental Policy Act, 42 U.S.C. 4321–4375, requires federal agencies to analyze proposed actions to determine whether the action will have a significant impact on the human environment. The Council on Environmental Quality (CEQ) regulations require federal agencies to conduct an environmental review considering: (1) The need for the proposed action; (2) alternatives to the proposed action; (3) probable environmental impacts of the proposed action and alternatives; and (4) the agencies and persons consulted during the consideration process. PHMSA proposes to make miscellaneous amendments to the HMR based on PHMSA's own initiatives including a review of the HMR, previous letters of interpretation and special permits we issued. The proposed amendments are intended to update, clarify, or provide relief from certain existing regulatory requirements to promote safer transportation practices; eliminate unnecessary regulatory requirements; facilitate international commerce; and make these requirements easier to understand.

Description of Action:

Docket No. PHMSA–2011–0138 (HM–218G), NPRM

Transportation of hazardous materials in commerce is subject to requirements in the HMR, issued under authority of Federal hazardous materials transportation law, codified at 49 U.S.C. 5001 et seq. To facilitate the safe and efficient transportation of hazardous materials in international commerce, the HMR provide that both domestic and international shipments of hazardous materials may be offered for transportation and transported under provisions of the international regulations.

Proposed Amendments to the HMR:

In this NPRM, PHMSA is proposing to:

- Permit designated agents for non-residents to submit designation requests by electronic mail in addition to traditional mail.

- Add the TSI “Molten Sulphur Rail Tank Car Guidance” document to the list of informational materials not requiring incorporation by reference in § 171.7.

- Revise the § 172.101 HMT to correct an error in the transportation requirements for entries listed under the proper shipping name, “Hydrazine Dicarboxylic Acid Diazide.”

- Revise the § 172.101 HMT to remove the entry for “Zinc ethyl, see Diethylzinc” which was superseded by proper shipping names adopted in a previous rulemaking.

- Revise special provision 138 in § 172.102 to clarify the lead solubility calculation utilized for classification of material as a Marine Pollutant.

- Remove references to special provisions B72 and B74 in § 172.102. These special provisions were removed in a previous rulemaking, however, twelve entries in the § 172.101 HMT still contain references to these special provisions.

- Revise the shipping paper requirements in § 172.203(e) to permit the phrase “Residue last contained” to be placed before or after the basic shipping description sequence, or for rail shipment, directly preceding the proper shipping name in the basic shipping description sequence.

- Update the training recordkeeping requirements in § 172.704 to specify that a hazardous materials (hazmat) employer must make hazmat employee training records available upon request, at a reasonable time and location, to an authorized official of the Department of Transportation or the Department of Homeland Security.

- Clarify that the material of trade exception in § 173.6 may be used when transporting Division 2.1 and 2.2 gases in Dewar flasks.

- Clarify the lab pack provisions in § 173.12 pertaining to temperature-controlled materials contained in a lab pack.

- Clarify the exceptions for external emergency self-closing valves on CTMVs in § 173.33(g) to specify that external emergency self-closing valves on MC 338 cargo tanks containing cryogenic liquids may remain open during transportation.

- Correct an inadvertent deletion of the § 173.62 packaging requirements for explosives.

- Incorporate DOT SP–13556 into § 173.134, to authorize the transportation by motor vehicle of certain regulated medical wastes, designated as sharps, in non-DOT specification containers fitted into wheeled racks.

- Revise the requirements for cargo air transport of alcoholic beverages § 173.150 to harmonize with the ICAO TI.

- Clarify the exceptions in § 173.159a for non-spillable batteries secured to skids or pallets.

- Revise § 178.2(c) to clarify the applicability of the notification requirements for packages containing residues.

- Clarify the inspection record requirements in § 180.416 for discharge systems of cargo tanks transporting liquefied compressed gases.

- Clarify the requirements for the Flame Penetration Resistance test required for chemical oxygen generators and certain compressed gases in Appendix E to Part 178.

Alternatives Considered:

Alternative (1): Do nothing.

Our goal is to update, clarify and provide relief from certain existing regulatory requirements to promote safer transportation practices, eliminate unnecessary regulatory requirements, and facilitate international commerce. We rejected the do-nothing alternative.

Alternative (2): Go forward with the proposed amendments to the HMR in this NPRM.

This is the selected alternative.

Environmental Consequences

Hazardous materials are substances that may pose a threat to public safety or the environment during transportation because of their physical, chemical, or nuclear properties. The hazardous materials regulatory system is a risk management system that is prevention oriented and focused on identifying a safety hazard and reducing the probability and quantity of a hazardous material release. Hazardous materials are categorized by hazard analysis and experience into hazard classes and packing groups. The regulations require each shipper to classify a material in accordance with these hazard classes and packing groups. The process of classifying a hazardous material is itself a form of hazard analysis. Further, the regulations require the shipper to communicate a material's hazards through use of the hazard class, packing group, and proper shipping name on the shipping paper and the use of labels on packages and placards on transport vehicles. Thus, the shipping paper, labels, and placards communicate the most significant findings of the shipper's hazard analysis. A hazardous material is assigned to one of three packing groups based upon its degree of hazard, from a high hazard, Packing Group I to a low

hazard, Packing Group III material. The quality, damage resistance, and performance standards of the packaging in each packing group are appropriate for the hazards of the material transported.

Under the HMR, hazardous materials are transported by aircraft, vessel, rail, and highway. The potential for environmental damage or contamination exists when packages of hazardous materials are involved in accidents or en route incidents resulting from cargo shifts, valve failures, package failures, loading, unloading, collisions, handling problems, or deliberate sabotage. The release of hazardous materials can cause the loss of ecological resources (e.g. wildlife habitats) and the contamination of air, aquatic environments, and soil. Contamination of soil can lead to the contamination of ground water. Compliance with the HMR substantially reduces the possibility of accidental release of hazardous materials.

Conclusion

PHMSA proposes to make miscellaneous amendments to the HMR based on comments from the regulated community and PHMSA's own rulemaking initiatives. The proposed amendments are intended to update, clarify, or provide relief from certain existing regulatory requirements to promote safer transportation practices; eliminate unnecessary regulatory requirements; facilitate international commerce; and make these requirements easier to understand. These proposed clarifications of regulatory requirements, if adopted, will foster a greater level of compliance with the HMR and thus, diminished levels of hazardous materials transportation incidents affecting the health and safety of the environment. Therefore, the net environmental impact of this proposal will be positive.

J. Privacy Act

Anyone is able to search the electronic form of any written communications and comments received into any of our dockets by the name of the individual submitting the document (or signing the document, if submitted on behalf of an association, business, labor union, etc.). You may review DOT's complete Privacy Act Statement in the **Federal Register** published on April 11, 2000 (65 FR 19477), or you may visit <http://www.regulations.gov/search/footer/privacypanduse.jsp>.

www.regulations.gov/search/footer/privacypanduse.jsp.

K. International Trade Analysis

The Trade Agreements Act of 1979 (Pub. L. 96-39), as amended by the Uruguay Round Agreements Act (Pub. L. 103-465), prohibits Federal agencies from establishing any standards or engaging in related activities that create unnecessary obstacles to the foreign commerce of the United States. Pursuant to these Acts, the establishment of standards are not considered unnecessary obstacles to the foreign commerce of the United States, so long as the standards have a legitimate domestic objective, such as the protection of safety, and do not operate in a manner that excludes imports that meet this objective. The statute also requires consideration of international standards and, where appropriate, that they be the basis for U.S. standards. PHMSA notes the purpose is to ensure the safety of the American public, and has assessed the effects of this rule to ensure that it does not exclude imports that meet this objective. As a result, this proposed rule is not considered as creating an unnecessary obstacle to foreign commerce.

List of Subjects

49 CFR Part 105

Administrative practice and procedure, Hazardous materials transportation, Penalties, Reporting and recordkeeping requirements.

49 CFR Part 171

Exports, Hazardous materials transportation, Hazardous waste, Imports, Incorporation by reference, Reporting and recordkeeping requirements.

49 CFR Part 172

Education, Hazardous materials transportation, Hazardous waste, Incorporation by reference, Labeling, Markings, Packaging and containers, Reporting and recordkeeping requirements.

49 CFR Part 173

Hazardous materials transportation, Incorporation by reference, Packaging and containers, Radioactive materials, Reporting and recordkeeping requirements, Uranium.

49 CFR Part 177

Hazardous materials transportation, Loading and unloading, Segregation and separation.

49 CFR Part 178

Hazardous materials transportation, Incorporation by reference, Motor vehicle safety, Packaging and containers, Reporting and recordkeeping requirements.

49 CFR Part 180

Hazardous materials transportation, Motor carriers, Motor vehicle safety, Packaging and containers, Railroad safety, Reporting and recordkeeping requirements.

In consideration of the foregoing, we propose to amend 49 CFR chapter I as follows:

PART 105—HAZARDOUS MATERIALS PROGRAM PROCEDURES

1. The authority citation for part 105 continues to read as follows:

Authority: 49 U.S.C. 5101-5127; 49 CFR 1.53.

2. In § 105.40, paragraph (d) is revised to read as follows:

§ 105.40 Designated agents for non-residents.

* * * * *

(d) Each designation must be submitted to: Approvals and Permits Division, Pipeline and Hazardous Materials Safety Administration, Attn: PHH-30, U.S. Department of Transportation, East Building, 1200 New Jersey Avenue SE., Washington, DC 20590-0001 or by electronic mail to: specialpermits@dot.gov or approvals@dot.gov as appropriate.

* * * * *

PART 171—GENERAL INFORMATION, REGULATIONS, AND DEFINITIONS

3. The authority citation for part 171 continues to read as follows:

Authority: 49 U.S.C. 5101-5128, 44701; 49 CFR 1.45 and 1.53; Pub. L. 101-410 section 4 (28 U.S.C. 2461 note); Pub. L. 104-134, section 31001.

4. In § 171.7, in the paragraph (b) table, the following entry is added:

§ 171.7 Reference material.

(b) * * *

| Source and name of material | 49 CFR reference |
|--|------------------|
| <p style="text-align: center;">* * * * *</p> <p><i>The Sulphur Institute</i>, 1140 Connecticut Avenue NW., Washington, DC 20036 Molten Sulphur Rail Tank Car Guidance document, November 2011 final edition</p> | 172.102 |
| <p style="text-align: center;">* * * * *</p> | |

* * * * *

**PART 172—HAZARDOUS MATERIALS
 TABLE, SPECIAL PROVISIONS,
 HAZARDOUS MATERIALS
 COMMUNICATIONS, EMERGENCY
 RESPONSE INFORMATION, AND
 TRAINING REQUIREMENTS**

5. The authority citation for part 172 continues to read as follows:

Authority: 49 U.S.C. 5101–5128, 44701; 49 CFR 1.53.

6. In § 172.101, the Hazardous Materials Table is amended by removing the entries under “[REMOVE]”, by adding the entries under “[ADD]” and revising entries under “[REVISE]” in the appropriate alphabetical sequence to read as follows:

§ 172.101 Purpose and use of hazardous materials table.

* * * * *

§ 172.101—HAZARDOUS MATERIALS TABLE

| (1) Symbols | (2) Hazardous materials descriptions and proper shipping names | (3) Hazard class or division | (4) Identification numbers | (5) PG | (6) Label codes | (7) Special provisions (§ 172.102) | (8) Packaging (§ 173.***) | | (9) Quantity limitations | | (10) Vessel stowage | |
|----------------|---|---------------------------------|-------------------------------|-----------|-------------------------------|--|------------------------------|------------------|-----------------------------|---------------------------------|-----------------------------|-------------------|
| | | | | | | | (8A) Exceptions | (8B) Non-bulk | (8C) Bulk | (9A) Passenger aircraft/rail | (9B) Cargo aircraft only | (10A) Location |
| | [REMOVE] | | | | | | | | | | | |
| | Hydrazine dicarbonic acid diazide. | * Forbidden | * | | * | * | | * | * | | | |
| II | | | 8, 6.1 | | B16, B53, IB2, T7, TP2, TP13. | None | 202 | 243 | Forbidden | 30 L | D | 40 |
| III | | | 8, 6.1 | | B16, B53, IB3, T4, TP1. | 154 | 203 | 241 | 5 L | 60 L | D | 40 |
| | Zinc ethyl, see Diethylzinc. | * | * | | * | * | * | * | * | | | |
| | [ADD] | | | | | | | | | | | |
| | Hydrazine dicarbonic acid diazide. | * Forbidden | * | | * | * | * | * | * | | | |
| 3 | UN3469 | II | | | 3, 8 | IB2, T7, TP2, TP8, TP28. | 150 | 202 | 243 | 1 L | 5 L | B |
| III | | | | | 3, 8 | IB3, T4, TP1, TP29. | 150 | 203 | 242 | 5 L | 60 L | A |
| | Paint related material, flammable, corrosive (including paint thinning or reducing compound). | * | * | | * | * | * | * | * | | | |
| | [REVISE] | | | | | | | | | | | |
| 6.1 | UN2484 | I | | | 6.1, 3 | 1, B9, B14, B30, T20, TP2, TP13, TP38, TP44. | None | 226 | 244 | Forbidden | Forbidden | D |
| | tert-Butyl isocyanate | * | * | | * | * | * | * | * | | | |
| 6.1 | NA2927 | I | | | 6.1, 8 | 2, B9, B14, B32, T20, TP4, TP12, TP13, TP38, TP45. | None | 227 | 244 | Forbidden | Forbidden | D |
| | Ethyl phosphonothioic dichloride, anhydrous. | * | * | | * | * | * | * | * | | | |
| 6.1 | NA2845 | I | | | 6.1, 4.2 | 2, B9, B14, B32, T20, TP4, TP12, TP13, TP38, TP45. | None | 227 | 244 | Forbidden | Forbidden | D |
| | Ethyl phosphonous dichloride, anhydrous pyrophoric liquid. | * | * | | * | * | * | * | * | | | |
| 6.1 | NA2927 | I | | | 6.1, 8 | 2, B9, B14, B32, T20, TP4, TP12, TP13, TP38, TP45. | None | 227 | 244 | Forbidden | Forbidden | D |
| | Ethyl phosphorodichloride. | * | * | | * | * | * | * | * | | | |

| | | | | | | | | | | | | | | | | | | | | | | | |
|---|--|---|-----|--------|-----|-----|-------|---|-----------|-------|---|---|------|-------|-----|-------|-----|-------|-----------|-----------|---|-------|---------|
| D | Methyl phosphonous di- chloride, pyrophoric liq- uid. | * | 6.1 | NA2845 | ... | I | | * | 6.1, 4.2 | | 2, B9, B14, B16, B32, T20, TP4, TP12, TP13, TP38, TP45. | * | None | | 227 | | 244 | | Forbidden | Forbidden | D | | 18 |
| + | Sulfuric acid, fuming with 30 percent or more free sulfur trioxide. | * | 8 | UN1831 | ... | I | | * | 8, 6.1 | | 2, B9, B14, B32, B77, B84, N34, T20, TP2, TP12, TP13. | * | None | | 227 | | 244 | | Forbidden | Forbidden | C | | 14, 40 |
| D | Sulfur, molten | * | 9 | NA2448 | ... | III | | * | 9 | | 30, B13, IB3, R1, T1, TP3. | * | None | | 213 | | 247 | | Forbidden | Forbidden | C | | 61 |
| I | Sulfur, molten | * | 4.1 | UN2448 | ... | III | | * | 4.1 | | 30, B13, IB1, R1 T1, TP3. | * | None | | 213 | | 247 | | Forbidden | Forbidden | C | | 74 |
| G | Toxic by inhalation liquid, corrosive, flammable, n.o.s. with an inhalation toxicity lower than or equal to 200 ml/m3 and saturated vapor con- centration greater than or equal to 500 LC50. | * | 6.1 | UN3492 | ... | I | | * | 6.1, 8, 3 | | 1, B9, B14, B30, T22, TP2, TP13, TP27, TP38, TP44. | * | None | | 226 | | 244 | | Forbidden | Forbidden | D | | 40, 125 |
| G | Toxic by inhalation liquid, corrosive, flammable, n.o.s. with an inhalation toxicity lower than or equal to 1000 ml/m3 and saturated vapor concentration greater than or equal to 10 LC50. | * | 6.1 | UN3493 | ... | I | | * | 6.1, 8, 3 | | 2, B9, B14, B32, T20, TP2, TP13, TP27, TP38, TP45. | * | None | | 227 | | 244 | | Forbidden | Forbidden | D | | 40, 125 |
| G | Toxic by inhalation liquid, flammable, corrosive, n.o.s. with an inhalation toxicity lower than or equal to 200 ml/m3 and saturated vapor con- centration greater than or equal to 500 LC50. | * | 6.1 | UN3488 | ... | I | | * | 6.1, 3, 8 | | 1, B9, B14, B30, T22, TP2, TP13, TP27, TP38, TP44. | * | None | | 226 | | 244 | | Forbidden | Forbidden | D | | 40, 125 |
| G | Toxic by inhalation liquid, flammable, corrosive, n.o.s. with an inhalation toxicity lower than or equal to 1000 ml/m3 and saturated vapor concentration greater than or equal to 10 LC50. | * | 6.1 | UN3489 | ... | I | | * | 6.1, 3, 8 | | 2, B9, B14, B32, T20, TP2, TP13, TP27, TP38, TP45. | * | None | | 227 | | 244 | | Forbidden | Forbidden | D | | 40, 125 |

§ 172.101—HAZARDOUS MATERIALS TABLE—Continued

| Symbols | Hazardous materials descriptions and proper shipping names | Hazard class or division | Identification numbers | PG | Label codes | Special provisions (§ 172.102) | Packaging (§ 173.***) | | Quantity limitations | | Vessel stowage | | |
|---------|---|--------------------------|------------------------|-----|-------------|--|-----------------------|----------|-------------------------|---------------------|----------------|-------|----------------|
| | | | | | | | Exceptions | Non-bulk | Passenger aircraft/rail | Cargo aircraft only | Location | Other | |
| (1) | (2) | (3) | (4) | (5) | (6) | (7) | (8A) | (8B) | (8C) | (9A) | (9B) | (10A) | (10B) |
| G | Toxic by inhalation liquid, water-reactive, flammable, n.o.s. with an inhalation toxicity lower than or equal to 200 ml/m ³ and saturated vapor concentration greater than or equal to 500 LC50. | 6.1 | UN3490 | I | 6.1, 4.3, 3 | 1, B9, B14, B30, T22, TP2, TP13, TP27, TP38, TP44. | None | 226 | 244 | Forbidden | Forbidden | (10A) | 21, 28, 40, 49 |
| G | Toxic by inhalation liquid, water-reactive, flammable, n.o.s. with an inhalation toxicity lower than or equal to 1000 ml/m ³ and saturated vapor concentration greater than or equal to 10 LC50. | 6.1 | UN3491 | I | 6.1, 4.3, 3 | 2, B9, B14, B32, T20, TP2, TP13, TP27, TP38, TP45. | None | 227 | 244 | Forbidden | Forbidden | (10A) | 21, 28, 40, 49 |

* * * * *

7. In § 172.102, special provision 138 is added in paragraph (c)(1) and special provision R1 in paragraph (c)(6) is revised to read as follows:

§ 172.102 Special Provisions.

* * * * *

(c) * * *

(1) * * *

138 This entry applies to lead compounds which, when mixed in a ratio of 1:1,000 with 0.07 M (Molar concentration) hydrochloric acid and stirred for one hour at a temperature of 23 °C ± 2 °C, exhibit a solubility of more than 5 percent. Lead compounds which, when mixed in a ratio of 1:1,000 with 0.07 M (Molar concentration) hydrochloric acid and stirred for one hour at a temperature of 23 °C ± 2 °C, exhibit a solubility of 5 percent or less are not subject to the requirements of this subchapter unless they meet criteria as another hazard class or division. Lead compounds that have a solubility of 5 percent or less in accordance with this special provision are not subject to the requirements of this subchapter that pertain to Marine Pollutants.

* * * * *

(6) * * *

R1 A person who offers for transportation tank cars containing sulfur, molten or residue of sulfur, molten may reference the Sulphur Institute's, "Molten Sulphur Rail Tank Car Guidance document" (see § 171.7 of this subchapter) to identify tank cars that may pose a risk in transportation due to the accumulation of molten sulfur on the outside of the tank.

* * * * *

8. In § 172.203 paragraph (e) is revised to read as follows:

§ 172.203 Additional description requirements.

* * * * *

(e) * * * (1) The description on the shipping paper for a packaging containing the residue of a hazardous material may include the words "RESIDUE: Last Contained * * *" immediately before or after the basic shipping description on the shipping paper.

(2) The description on the shipping paper for a tank car containing the

residue of a hazardous material must include the phrase, "RESIDUE: LAST CONTAINED * * *" immediately before or after the basic shipping description or immediately preceding the proper shipping name of the material on the shipping paper.

9. In § 172.704, paragraph (d) is revised to read as follows:

§ 172.704 Training requirements.

* * * * *

(d) Recordkeeping. Each hazmat employer must create and retain a record of current training of each hazmat employee, inclusive of the preceding three years, in accordance with this section for as long as that employee is employed by that employer as a hazmat employee and for 90 days thereafter. A hazmat employer must make a hazmat employee's record of current training available upon request, at a reasonable time and location, to an authorized official of the Department of Transportation or the Department of Homeland Security. The record must include:

* * * * *

PART 173—SHIPPERS—GENERAL REQUIREMENTS FOR SHIPMENTS AND PACKAGINGS

10. The authority citation for part 173 continues to read as follows:

Authority: 49 U.S.C. 5101–5128, 44701; 49 CFR 1.45 and 1.53.

11. In § 173.6, paragraph (a)(2) is revised to read as follows:

§ 173.6 Materials of trade exceptions.

* * * * *

(a) * * *

(2) A Division 2.1 or 2.2 material in a cylinder with a gross weight not over 100 kg (220 pounds), in a Dewar flask meeting the requirements of § 173.320, or a permanently mounted tank manufactured to the ASME Code of not more than 70 gallon water capacity for a non-liquefied Division 2.2 material with no subsidiary hazard.

* * * * *

12. In § 173.12, paragraph (b)(3) is revised to read as follows:

§ 173.12 Exceptions for shipment of waste materials.

* * * * *

(b) * * *

(3) *Prohibited materials.* The following waste materials may not be packaged or described under the provisions of this paragraph (b): a material poisonous-by-inhalation, a temperature controlled material unless it complies with § 173.21(f)(1), a Division 6.1, Packing Group I material, chloric acid, and oleum (fuming sulfuric acid).

* * * * *

13. In § 173.33, paragraph (g) is revised to read as follows:

§ 173.33 Hazardous materials in cargo tank motor vehicles.

* * * * *

(g) *Remote control of self-closing stop valves—MC 330, MC 331 and MC 338 cargo tanks.* Each liquid or vapor discharge opening in an MC 330 or MC 331 cargo tank and each liquid filling and liquid discharge line in an MC 338 cargo tank must be provided with a remotely controlled internal self-closing stop valve, except when an MC 330 or MC 331 cargo tank is marked and used exclusively to transport carbon dioxide, or except when an MC 338 is used to transport argon, carbon dioxide, helium, krypton, neon, nitrogen, and xenon, or except when an MC 338 utilizes an external self-closing stop valve to comply with the requirements in § 178.338–11(b). However, if the cargo tank motor vehicle was certified before January 1, 1995, this requirement is applicable only when an MC 330 or MC 331 cargo tank is used to transport a flammable liquid, flammable gas, hydrogen chloride (refrigerated liquid), or anhydrous ammonia; or when an MC 338 cargo tank is used to transport flammable ladings.

* * * * *

14. In § 173.62, in paragraph (c)(5), in the Table of Packing Methods, Packing Instructions 130 is revised to read as follows:

§ 173.62 Specific packaging requirements for explosives.

* * * * *

(c) * * *

(5) * * *

TABLE OF PACKING METHODS

| Packaging instruction | Inner packagings | Intermediate packagings | Outer packaging |
|---|---------------------|-------------------------|---|
| <p>130 Particular Packaging Requirements: 1. The following applies to UN 0006, 0009, 0010, 0015, 0016, 0018, 0019, 0034, 0035, 0038, 0039, 0048, 0056, 0137, 0138, 0168, 0169, 0171, 0181, 0182, 0183, 0186, 0221, 0238, 0243, 0244, 0245, 0246, 0254, 0280, 0281, 0286, 0287, 0297, 0299, 0300, 0301, 0303, 0321, 0328, 0329, 0344, 0345, 0346, 0347, 0362, 0363, 0370, 0412, 0424, 0425, 0434, 0435, 0436, 0437, 0438, 0451, 0459 and 0488. Large and robust explosives articles, normally intended for military use, without their means of initiation or with their means of initiation containing at least two effective protective features, may be carried unpackaged. When such articles have propelling charges or are self-propelled, their ignition systems must be protected against stimuli encountered during normal conditions of transport. A negative result in Test Series 4 on an unpackaged article indicates that the article can be considered for transport unpackaged. Such unpackaged articles may be fixed to cradles or contained in crates or other suitable handling devices.. 2. Subject to approval by the Associate Administrator, large explosive articles, as part of their operational safety and suitability tests, subjected to testing that meets the intentions of Test Series 4 of the UN Manual of Tests and Criteria with successful test results, may be offered for transportation in accordance with the requirements of this subchapter.</p> | Not necessary | Not necessary | Boxes. Steel (4A). Aluminum (4B) Wood natural, ordinary (4C1). Wood natural, sift-proof walls (4C2) Plywood (4D). Reconstituted wood (4F). Fiberboard (4G). Plastics, expanded (4H1). Plastics, solid (4H2). Drums. Steel, removable head (1A2). Aluminum, removable head (1B2). Plywood (1D). Fiber (1G). Plastics, removable head (1H2). Large Packagings. Steel (50A) Aluminum (50B) Metal other than steel or aluminum (50N) Rigid plastics (50H) Natural wood (50C) Plywood (50D) Reconstituted wood (50F) Rigid fiberboard (50G). |

15. In § 173.134, paragraph (c)(2) is revised to read as follows:

§ 173.134 Class 6, Division 6.2—Definitions and exceptions.

- (c) * * *
- (2) * * *
- (viii) Documents intended for destruction in accordance with the Health Insurance Portability and Accountability Act of 1996 (HIPAA) requirements;
- (ix) Medical or clinical equipment and laboratory products provided they are properly packaged and secured against exposure or contamination; and
- (x) Sharps in sharp containers provided the containers are securely closed to prevent leaks or punctures; do not exceed 18 gallons capacity; registered under the Medical Device Regulations of FDA; made of puncture resistant plastic that meets ASTM Standard F2132–01, Standard

Specification for Puncture Resistance of Materials Used in Containers for Discarded Medical Needles and Other Sharps; and are securely fitted into wheeled racks that hold them in an upright position. The wheeled racks must contain full rows of sharps containers secured in place by a moveable bar; and must be securely held in place on the motor vehicle by straps or load bars during transportation. No shelf in any wheeled rack may exceed the manufacturer's recommended load capacity.

* * * * *

16. In § 173.150, paragraph (d) is revised to read as follows:

§ 173.150 Exceptions for Class 3 (flammable and combustible liquids).

* * * * *

(d) Alcoholic beverages. (1) An alcoholic beverage (wine and distilled spirits as defined in 27 CFR §§ 4.10 and

5.11), when transported via motor vehicle, vessel, or rail, is not subject to the requirements of this subchapter if the alcoholic beverage:

- (i) Contains 24 percent or less alcohol by volume;
- (ii) Is contained in an inner packaging of 5 L (1.3 gallons) or less; or
- (iii) Is a Packing Group III alcoholic beverage contained in a packaging 250 liters (66 gallons) or less;
- (2) An alcoholic beverage (wine and distilled spirits as defined in 27 CFR §§ 4.10 and 5.11), when transported via aircraft, is not subject to the requirements of this subchapter if the alcoholic beverage:
 - (i) Contains 24 percent or less alcohol by volume;
 - (ii) For transportation aboard a passenger-carrying aircraft, contains more than 24 percent but less than 70 percent alcohol by volume when in unopened retail packagings not exceeding 5 liters (1.3 gallons) carried in

carry-on or checked baggage, with a total net quantity per person of 5 liters (1.3 gallons) (See § 175.10(a)(4)).

(iii) For transportation aboard a cargo aircraft contains more than 24 percent but less than 70 percent alcohol by volume in an inner packaging of 5 L (1.3 gallons) or less.

* * * * *

17. In § 173.159a, paragraph (c)(1) is revised to read as follows:

§ 173.159a Exceptions for non-spillable batteries.

* * * * *

(c) Non-spillable batteries are excepted from the packaging requirements of § 173.159 under the following conditions:

(1) Non-spillable batteries must be securely packed in strong outer packagings or secured to skids or pallets capable of withstanding the shocks normally incident to transportation. The batteries must meet the requirements of § 173.159(a), be loaded or braced so as to prevent damage and short circuits in transit, and any other material loaded in the same vehicle must be blocked, braced, or otherwise secured to prevent contact with or damage to the batteries. A non-spillable battery which is an

integral part of and necessary for the operation of mechanical or electronic equipment must be securely fastened in the battery holder on the equipment.

* * * * *

PART 177—CARRIAGE BY PUBLIC HIGHWAY

18. The authority citation for part 177 continues to read as follows:

Authority: 49 U.S.C. 5101–5127; 49 CFR 1.53.

19. In § 177.834, paragraph (j)(2) is revised to read as follows:

§ 177.834 General requirements.

* * * * *

(j) * * *

(2) All valves and other closures in liquid discharge systems are closed and free of leaks, except external emergency self-closing valves on MC 338 cargo tanks containing the residue of cryogenic liquids may remain either open or closed during transit.

* * * * *

PART 178—SPECIFICATIONS FOR PACKAGINGS

20. The authority citation for part 178 continues to read as follows:

Authority: 49 U.S.C. 5101–5128; 49 CFR 1.53.

21. In § 178.2, paragraph (c)(1) is revised to read as follows:

§ 178.2 Applicability and responsibility.

* * * * *

(c) *Notification.* (1) Except as specifically provided in §§ 178.337–18, 178.338–19 and 178.345–15 of this part or for empty packagings meeting the requirements specified in § 173.29(b), the manufacturer or other person certifying compliance with the requirements of this part, and each subsequent distributor of that packaging must:

* * * * *

22. In Appendix E to part 178 Figure 1 and Figure 2 are added following the text.

Appendix E to Part 178—Flame Penetration Resistance Test

* * * * *

BILLING CODE 4910–60–P

Figure 1: Test Apparatus for Horizontal and Vertical Mounting

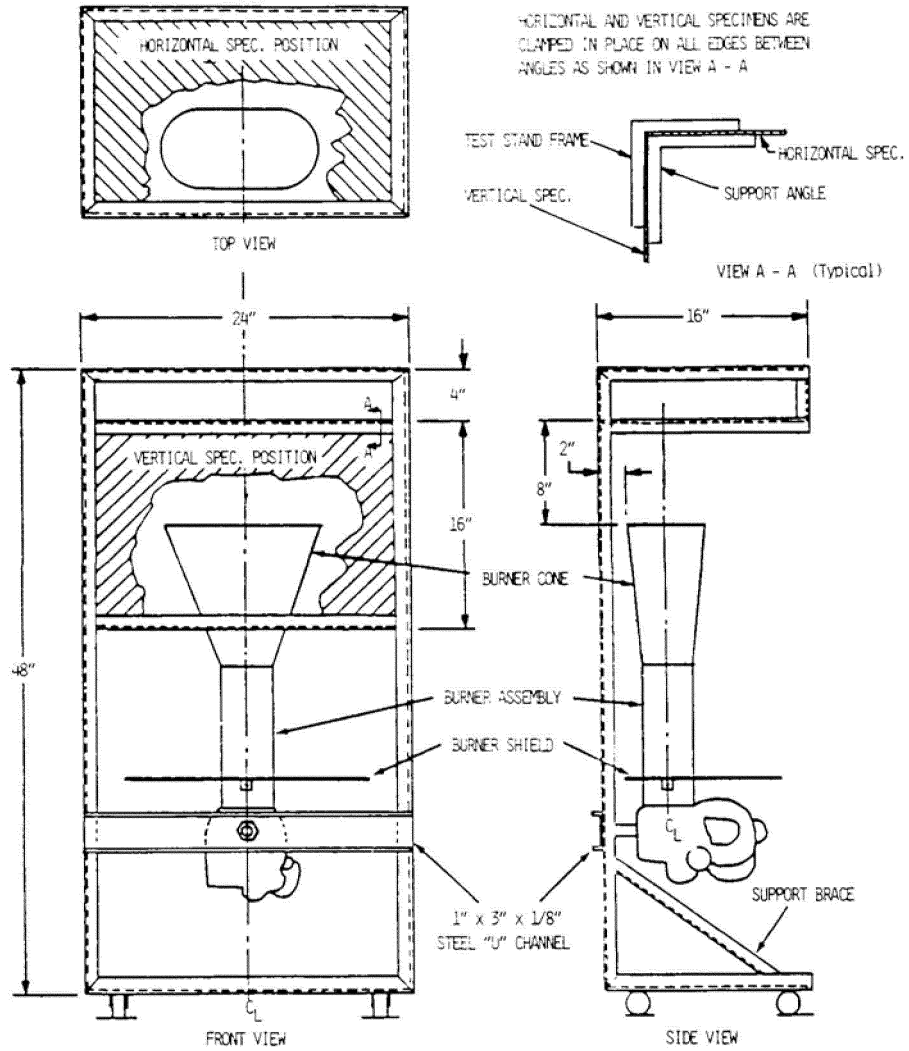

TEST STAND IS CONSTRUCTED WITH 1" x 1" x 1/8" STEEL ANGLES, ALL JOINTS WELDED
SUPPORT ANGLES ARE 1" x 1" x 1/8" CUT TO FIT

FIGURE 1. TEST APPARATUS FOR HORIZONTAL AND VERTICAL MOUNTING

Figure 2: Calorimeter Bracket

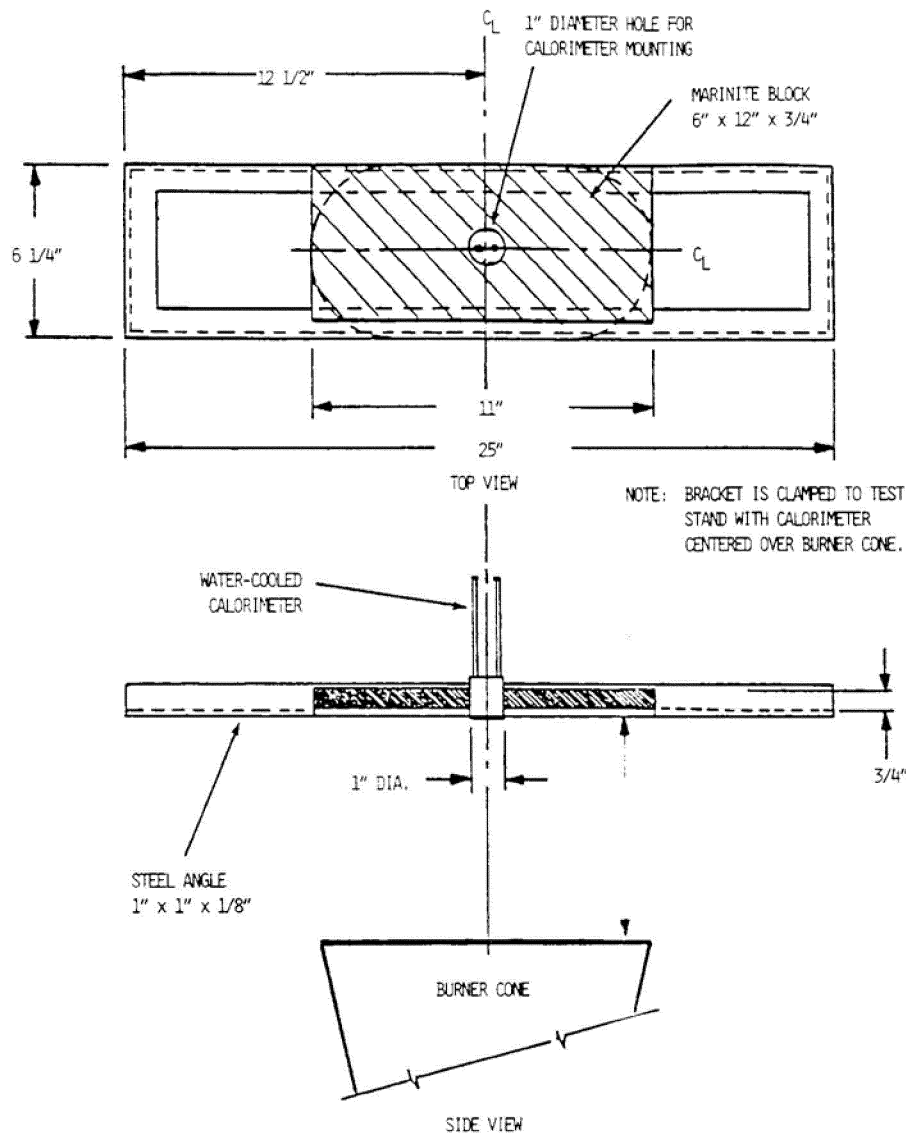

FIGURE 2. CALORIMETER BRACKET

BILLING CODE 4910-60-C

PART 180—CONTINUING QUALIFICATION AND MAINTENANCE OF PACKAGINGS

23. The authority citation for part 180 continues to read as follows:

Authority: 49 U.S.C. 5101-5128; 49 CFR 1.53.

24. In § 180.416, paragraph (d)(5) is revised to read as follows:

§ 180.416 Discharge system inspection and maintenance program for cargo tanks transporting liquefied compressed gases.

* * * * *

(d) * * *
 (5) The operator must note each inspection in a record. That record must include the inspection date, the name of the person performing the inspection, the hose assembly identification number, the manufacturer of the hose assembly, the date the hose was assembled and tested, and an indication that the delivery hose assembly and piping system passed or failed the tests and inspections. A copy of each test and

inspection record must be retained by the operator at its principal place of business or where the vehicle is housed or maintained until the next test of the same type is successfully completed.

* * * * *

Issued in Washington, DC, on April 19, 2012, under authority delegated in 49 CFR part 106.

R. Ryan Posten,
Deputy Associate Administrator for Hazardous Materials Safety, Pipeline and Hazardous Materials Safety Administration.

[FR Doc. 2012-9895 Filed 4-25-12; 8:45 am]

BILLING CODE 4910-60-P