

## CONSUMER PRODUCT SAFETY COMMISSION

### 16 CFR Part 1216

[CPSC Docket No. CPSC–2009–0066]

#### Safety Standard for Infant Walkers: Final Rule

**AGENCY:** Consumer Product Safety Commission.

**ACTION:** Final rule.

**SUMMARY:** Section 104(b) of the Consumer Product Safety Improvement Act of 2008 (“CPSIA”) requires the United States Consumer Product Safety Commission (“CPSC” or “Commission”) to promulgate consumer product safety standards for durable infant or toddler products. These standards are to be “substantially the same as” applicable voluntary standards or more stringent than the voluntary standard if the Commission concludes that more stringent requirements would further reduce the risk of injury associated with the product. The Commission is issuing a safety standard for infant walkers in response to the direction under section 104(b) of the CPSIA.<sup>1</sup>

**DATES:** The rule will become effective on December 21, 2010 and apply to products manufactured or imported on or after that date. The incorporation by reference of the publication listed in this rule is approved by the Director of the Federal Register as of December 21, 2010.

**FOR FURTHER INFORMATION CONTACT:** Carolyn Manley, Office of Compliance and Field Operations, Directorate for Engineering Sciences, Consumer Product Safety Commission, 4330 East West Highway, Bethesda, MD 20814; telephone (301) 504–7607; [cmanley@cpsc.gov](mailto:cmanley@cpsc.gov).

#### SUPPLEMENTARY INFORMATION:

##### A. Background and Statutory Authority

The Consumer Product Safety Improvement Act of 2008 (“CPSIA”, Pub. L. 110–314) was enacted on August 14, 2008. Section 104(b) of the CPSIA requires the Commission to promulgate consumer product safety standards for durable infant or toddler products. These standards are to be “substantially the same as” applicable voluntary standards or more stringent than the voluntary standard if the Commission

concludes that more stringent requirements would further reduce the risk of injury associated with the product. Section 104(b)(2) of the CPSIA directs the Commission to begin rulemaking for two standards by August 14, 2009. Under this provision, the Commission published a proposed standard for infant walkers in the **Federal Register** on September 3, 2009, 74 FR 45704. The standard is substantially the same as a voluntary standard developed by ASTM International (formerly known as the American Society for Testing and Materials), ASTM F 977–07, *Standard Consumer Safety Specification for Infant Walkers*, but with several modifications that strengthen the standard in order to reduce the risk of injury associated with walkers.

There are existing mandatory regulations applicable to baby bouncers, walker-jumpers, and baby walkers, which were originally issued in 1971 by the Food and Drug Administration. 16 CFR 1500.18(a)(6) and 16 CFR 1500.86(a)(4). These regulations do not address hazards associated with falls down stairs, structural integrity, occupant retention, or loading/stability issues. The ASTM F 977–07 standard contains provisions that the mandatory regulations lack or requirements that are more stringent than the mandatory standard. On September 3, 2009, the Commission proposed to revoke the existing CPSC regulations for baby bouncers, baby jumpers and walkers. As explained elsewhere in this issue of the **Federal Register**, the Commission has determined to revoke the existing regulations only with regard to walkers. They will remain in effect for baby bouncers and baby jumpers.

##### B. The Product

Infant walkers are used to support very young children before they are walking (usually 6 to 15 months old). ASTM F 977–07 defines “walker” as “a mobile unit that enables a child to move on a horizontal surface when propelled by the child sitting or standing within the walker, and that is in the manufacturer’s recommended use position.” Children may use walkers to sit, recline, bounce, jump, and use their feet to move around. Walkers typically consist of fabric seats attached to rigid trays. The trays are fastened to bases that have wheels or casters to make them mobile.

Currently, there are at least seven manufacturers or importers supplying walkers to the United States market (four domestic manufacturers, two foreign manufacturers with divisions in

the United States, and one domestic importer).

All known suppliers of infant walkers are members of the Juvenile Products Manufacturers Association (“JPMA”), the major United States trade association that represents juvenile product manufacturers and importers. Each supplies a variety of children’s products, of which walkers are only a small proportion. Infant walkers are available in many countries besides the United States, including China, the United Kingdom, and Australia. Therefore, any foreign manufacturer is a potential supplier to the United States market, either directly or indirectly through an importer.

Infant walkers made by all of the domestic manufacturers supplying walkers to the United States market are JPMA certified as compliant with the ASTM voluntary standard. Based on limited CPSC staff testing, CPSC staff does not believe that the two foreign manufacturers and the domestic importer are making walkers that are compliant with the voluntary standard.

Sales of infant walkers peaked in the early 1990s at less than 2 million annually. By 2005, however, annual walker sales had fallen to around 600,000. Following a similar pattern, walkers in use (the number of walkers estimated to still be in use, regardless of when sold) peaked in the mid-1990s, but have since fallen sharply as well (by 55 percent between 1996 and 2005). As of 2005, the estimated number of walkers in use was probably less than 2 million.

##### C. Incident Data

The preamble to the proposed rule summarized incident data involving walkers. There has been no change in the fatality reports or injury estimates related to walkers since publication of the proposed rule. That information is repeated below.

###### 1. Injury Estimates

There were an estimated total of 14,900 (an annual average of 3,000) injuries related to infant walkers among children under the age of 15 months that were treated in hospital emergency departments in the United States over the five-year period 2004–2008.<sup>2</sup> (This estimate has been adjusted to exclude jumpers from the walker code.) No deaths were reported through NEISS.

<sup>1</sup> The Commission voted 5–0 to approve publication of this rule. Commissioner Thomas Moore filed a statement concerning this action which may be viewed on the Commission’s Web site at <http://www.cpsc.gov/pr/statements.html> or obtained from the Commission’s Office of the Secretary.

<sup>2</sup> The source of injury estimates is the National Electronic Injury Surveillance System (“NEISS”), a statistically valid injury surveillance system based on data gathered from emergency departments of hospitals selected as a probability sample of all the United States hospitals with emergency departments.

There was no statistically significant increase or decrease observed in the estimated injuries from one year to the next, nor was there any statistically significant trend observed over the 2004–2008 period. For injuries requiring emergency department treatment that were related to infant walkers, the following characteristics occurred most frequently based on an annual average:

- Hazard—falls either out of the walker or down stairs/to a lower level while in the walker (62%).
- Injured body part—head (45%) and face (27%).
- Injury type—contusions/abrasions (37%) and internal organ injury (28%).
- Disposition—treated and released (90%) and hospitalized (5%).

For approximately 72 percent of the injuries reported, the walker was directly involved in the incident (such as the walker falling down stairs, tipping over, collapsing). However, many (nearly 20 percent) of the injuries treated in emergency departments were not necessarily caused by failures of the walkers.

As discussed in the preamble to the proposed rule (74 FR at 45705), the stair fall protection provisions in the ASTM standard dramatically affected incidents related to walkers (an 88% decrease in estimated incidents related to walkers treated in emergency rooms from 1994 to 2008). However, the stair fall hazard remains the most prevalent hazard in incidents related to walkers with some of these incidents involving walkers that do not comply with the voluntary standard, damaged or worn walkers, or children who are strong enough to lift the walker and defeat the stair fall protection.

## 2. Fatalities

CPSC staff has reports of eight fatal incidents involving an infant in a walker during the five year period 2004 to 2008.<sup>3</sup> One of these appears to involve a stair fall incident. The walker involved did not conform to the ASTM walker standard's stair fall performance requirements and had been under recall at the time of the death (due to the lack of stair fall protection). There were three deaths that resulted from accidental drowning when the child moved in a walker into a residential pool or spa. Two of these three deaths involved walkers that were certified to the JPMA standard, though pictures showed that one of the walkers was missing a wheel. The physical condition of the other

walker is unknown. The circumstances of the remaining four deaths varied and involved circumstances unrelated to falls (*i.e.*, a slow cooker overturned on an infant in a walker who pulled the cord of the cooker, an infant pulled a heavy dining chair on himself, an infant rolled down a driveway and struck a moving vehicle, and an infant aspirated a screw while seated in a walker).

## 3. Non-Fatal Injuries

A total of 78 non-fatal injuries were reported to have occurred between 2004 and 2008. All of these injuries occurred when the infant was seated in a walker. The leading cause of injury (about 42% of the injuries) was falls down the stairs or to a lower level. The next major cause of injury was product failure, either structural or mechanical failure of the walker, and these accounted for another 37% of the incidents. The attached toys, toy bars, or toy trays on the walker caused another 17% of the injuries, such as lacerations, abrasions, pinching, etc. Three percent of the non-fatal reported injuries were serious burn injuries resulting from infants pulling cords of small cooking appliances and spilling hot liquids onto themselves. Finally, one percent of the reported incidents did not specify the injury.

## D. Voluntary Standards

### 1. ASTM Voluntary Standard

ASTM F 977, *Standard Consumer Safety Specification for Infant Walkers*, was first published in 1986 and was revised in 1997 to address the stair fall hazard. The Commission's proposed rule, published September 3, 2009, was based on the 2007 version of the ASTM standard, ASTM F 977–07. In December 2009, ASTM published a revision to the infant walker standard, F 977–09. This revision included some of the changes in the Commission's proposed rule, but not the majority of them. The 2009 revision of the ASTM standard also included a significant change to the rearward facing stair fall test procedure for open back frame walker models. This test procedure was different from the test procedure the Commission proposed for these types of walkers. The proposed rule would require using a 1-inch aluminum angle firmly attached to the walker frame. The ASTM '09 version uses loops of cord and a lightweight floating bar. Because this method of attachment may not remain taut throughout the stair fall test, this procedure in the ASTM '09 version is not as stringent as the test method the Commission proposed for these types of walkers. For this reason, the final rule

incorporates by reference ASTM F 977–07 rather than the 2009 revision.

JPMA provides certification programs for juvenile products, including infant walkers. Manufacturers submit their products to an independent testing laboratory to test the product for conformance to the ASTM standard. Currently, infant walkers from five manufacturers are JPMA certified as being in compliance with the ASTM standard.

The ASTM standard includes performance requirements specific to infant walkers, general performance requirements, and labeling requirements. The key provisions of the ASTM infant walker standard include the following:

- Prevention of falls down stairs—intended to ensure that a walker will not fall down stairs when facing front, back, and sideways.
- Tipping resistance—intended to ensure that walkers are stable and do not tip over when on a flat surface; includes tests for forward and rear tip resistance, as well as for the occupant leaning over the front.
- Dynamic and static load testing on seating area—intended to ensure that the child remains fully supported while stationary and while bouncing/jumping.
- Occupant retention—intended to prevent entrapment by setting requirements for leg openings.

The ASTM standard also includes: (1) Torque and tension tests to assure that components cannot be removed; (2) requirements for several walker features to prevent entrapment and cuts (minimum and maximum opening size, accessible coil springs, leg openings, and edges that can scissor, shear, or pinch); (3) latching/locking mechanism requirements to assure that walkers do not accidentally fold while in use; (4) requirements for the permanency and adhesion of labels; and (5) requirements for instructional literature.

The stair fall protection requirement, also called the step test, is the key provision in the ASTM standard. For this test, a walker with a Civil Aeromedical Institute infant dummy (Mark II) (subsequently referred to as "CAMI dummy") is placed in the walker's seat which is propelled with a horizontal dynamic force by means of a pulley, rope, and a falling 8-pound weight on a hardwood floor surface. The walker passes the test if it stays on the test table which has a hardwood floor surface. It fails the test if the walker completely falls off the table surface.

The step test in the ASTM F 977–07 standard is based on the assumption that an average walker weighs 8 pounds. However, when CPSC staff weighed five

<sup>3</sup> The reported fatalities and non-fatalities are neither a complete count of all incidents that occurred during the period nor a sample of known probability of selection.

2008 to 2009 model walkers, the weight values ranged from 11 to 14 pounds. Computing the launching distance “d” as described in section 7.6 of ASTM F 977–07 depends on the weight of the walker, the weight of the CAMI dummy, the weight of the CAMI vest, the coefficient of friction between the walker wheels and the test table surface, and the maximum velocity at the edge of the test table platform (4 ft/sec or 2 ft/sec). According to section 7.6 of ASTM F 977–07, the d value for the forward and rearward directions with only the CAMI dummy seated in the walker is 14.6 inches. The d value for the forward and rearward directions with the CAMI dummy fitted with the 11-pound vest seated in the walker is 21.2 inches. The values of 14.6 inches and 21.2 inches were based on the assumption that the walker weight is 8 pounds. As in the proposed rule, the final rule requires calculation of the launching distance using the actual weight of the walker.

In the ASTM F 977–07 standard, most of the hardware and test apparatus components are not specified. Variability in the type and size of the pulley, rope type, test table flexure etc. can lead to different test results. Two different labs could test the same model walker and obtain different results. As in the proposed rule, the final rule adds specificity to these requirements.

## 2. European Standard EN 1273:2005

CPSC staff evaluated EN 1273:2005 European Standard and its two performance tests that are not in the ASTM F 977–07: the 30° incline plane stability test and the parking device test.

The Commission proposed adding the 30° incline plane test, which is a standard stability test common in several EN children’s product safety standards, to the walker mandatory standard. In this test, the walker, occupied by a 26.4 lb (12 kg) test mass is placed on a sloping platform inclined at 30° to the horizontal with a stop on the lower edge of the slope. The walker must not tip over. As explained in part F.2 of the preamble, the Commission is not including this test in the final rule.

The parking device test is only applicable to walkers that are equipped with a parking brake. It essentially requires conducting a semi-static version of the stair fall test, but with the parking device engaged. The walker must not move more than 1.97 inches (50 mm) in order to pass. The Commission proposed adding this test, and the final rule retains this addition.

## E. Response to Comments on the Proposed Rule

CPSC received seven comments regarding the proposed rule for infant walkers, including five from individuals, one from JPMA, and one from various consumer groups, including Consumers Union, Consumer Federation of America, and Kids in Danger. These comments and the Commission’s responses are discussed below.

### 1. Parking Brake Requirement and Warning

a. *Comment:* One commenter remarked that the parking brake requirement should be more stringent because parking brakes should keep the walker completely stationary and also commented that the proposed warning in the proposed rule is contradictory to the perception of a parking brake’s function. Another commenter recommended requiring parking brakes for all infant walkers.

*Response:* CPSC believes that the purpose of the parking brake warning is to alert the caregiver that the parking brake is used for temporarily preventing the walker from moving. In several ASTM meetings, some infant walker manufacturers have characterized the purpose of the parking brakes as such, and that the child in the walker must always be kept in view. The parking brake feature is added on some models for convenience to the caregiver. The parking brake is not meant to keep a child in the walker indefinitely without supervision. Also, the warning is meant to prevent any false sense of security by the caregiver. CPSC believes the proposed warning and the performance requirements as they appeared in the proposed rule are adequate.

b. *Comment:* One commenter supported the concept for having a performance test for walkers with parking brakes, but disagreed with the proposal to adopt the EN 1273:2005 European Standard’s test for parking brakes. The performance test is similar to that of the stair fall test, except that the 8-pound weight guided by a rope and pulley is released gradually and there is no set launching distance. Upon completion of the gradual 8-pound force application, the maximum allowable displacement (*i.e.*, movement) of the walker is 1.97 inches. The commenter argued that a lack of incidents involving parking devices supports its argument. In addition, the commenter compared the proposed parking device test to the ASTM F 2012, *Standard for Stationary Activity Centers*. The commenter asserted that a stationary activity center

is similar to that of an infant walker with its parking brakes engaged. Based on this comparison to stationary activity centers, the commenter advocated increasing the maximum allowable displacement to 6 inches in accordance with ASTM F 2012.

*Response:* CPSC believes that if a product is equipped with a feature, such as a parking brake, that feature should function properly and safely. Although CPSC is not aware of any incidents involving parking devices in the United States, the Commission believes that requiring the parking brake test is appropriate for the following reasons.

There are important distinctions between walkers and stationary activity centers. An infant in a walker tends to exert a horizontal force to propel himself or herself horizontally, whereas a child in a stationary activity center may not necessarily exert the same type of horizontally concentrated forces because the infant may be preoccupied jumping up and down, spinning about the seat, and playing with toys. The parking brake performance test should set limits on the displacement of the walker in the horizontal direction to resist motion when the parking brakes are engaged. The appropriate amount of force should be applied. Furthermore, upon comparison between ASTM F 2012 and EN 1273:2005, CPSC staff noted the following observations:

- A force gauge is used to apply the 8-pound force in ASTM F 2012 instead of a rope and pulley guided 8-pound weight as specified in EN 1273:2005. In the EN 1273:2005 test, the 8-pound weight is released gradually over a 5 second period and then hung from the test assembly for 1 minute. Arguably, the force of gravity is more consistent than a test technician applying a consistent rate of 8 pounds over a 10 second period (as in the ASTM F 2012 test). The longer duration of 1 minute is more stringent than 10 seconds.

- The location application of the 8-pound force in ASTM F 2012 has infinite variability as it is any location 2 inches above the floor level. The EN 1273:2005 standard requires the rope to be secured onto the bottom frame member of the infant walker which is arguably more consistent.

- In the “Rationale” section of ASTM F 2012, there is no mention of how the maximum allowable limit for displacement of 6 inches per minute was obtained.

EN 1273:2005’s maximum allowable 1.97-inch displacement is more stringent than ASTM F 2012’s 6 inches. Moreover, CPSC’s adoption of this performance test would harmonize with

the European EN 1273:2005 Standard for this requirement.

The Commission notes that this performance test is required only for infant walker models equipped with parking devices. Manufacturers can choose to exclude parking devices from their product.

The final rule retains the EN 1273:2005 performance test and maximum allowable displacement for 1.97 inches (CPSC staff assumes the commenter referred to 2 inches in its discussions for convenience) for parking devices as it was proposed in the proposed rule, except for an editorial change (discussed in the next response) to address some walkers that have fixed direction rear wheels.

*c. Comment:* The same commenter observed that the parking brake test, as written in the proposed rule, may present problems for measuring the displacement for walkers that have fixed direction wheels in the rear of the walker. With these types of wheels, the walker has a natural tendency to travel in a curved path instead of in a straight path. A walker with four casters does not have this issue.

*Response:* To address this subset of walkers, the final rule adds the following new paragraph to the language the Commission previously proposed for the sideward facing test of parking devices:

If the walker is equipped with fixed direction rear wheels and the walker is displaced in a curved path, establish the location of the rope attachment as the reference point and measure the linear displacement of that reference point after performing the procedure as described in paragraph (c)(3)(iii)(A) and (B).

## 2. The 30° Incline Plane Test

*Comment:* One commenter favored maintaining the cantilevered stability test as described in Section 7.3.4 of the ASTM F 977-07 Standard for infant walkers, and advocated eliminating the additional CPSC proposed 30° incline plane stability test to address tip over hazards.

*Response:* From the time CPSC staff recommended the 30° incline plane test (based on EN 1273:2005), numerous discussions about the added benefits of the 30° incline plane stability test have occurred among CPSC staff and ASTM. Over the past year, these discussions have taken place at ASTM headquarters, as well as in conference calls. A JPMA member was tasked to perform analyses on the two test methods to determine if the 30° incline plane test is needed. During ASTM's presentation at the October 13, 2009 meeting, the JPMA member demonstrated using real

examples that Section 7.3.4 stability test of the ASTM F 977-07 Standard is adequate and that the 30° incline plane test is not needed. The analyses included a comparison of the two stability test methods using the dimensions of an exemplar walker and concluded that the 30° incline plane test was not as severe as the Section 7.3.4 stability test. CPSC staff concurred with this presentation and the comparison of stability test methods. Therefore, the final rule does not include the 30° incline plane test that was in the proposed rule.

## 3. Adding Calculation To Determine Launching Distance To Step Test Procedures

*Comment:* One commenter objected to the proposed rule's proposal to change the fixed distances in the step test to a computed value for *d* which will vary due to the weight of the test sample walkers. The commenter asserted that increasing the launching distance for heavier walkers is not necessary or is "self correcting" because a child seated in the heavier walker will naturally not move as fast. The commenter requested keeping the launching distances as they are in Table 1 of Section 7.6 of the ASTM F 977-07 Standard. The commenter also commented that no incident data indicates a need to change velocities in the step test.

*Response:* As discussed in the preamble to the proposed rule (74 FR at 45706), the Commission believes that the step test requirements should be modified to account for heavier modern walkers. The 8-pound walker used to develop the ASTM step requirement for the original 1997 standard is now outdated because the average modern walker is heavier than 8 pounds.

The critical parameter of the step test is the velocity of a walker with a child in it. CPSC staff believes that it would be more robust to assume that the child maintains a 4 feet/second top speed, regardless of the walker's weight. CPSC staff showed that children can achieve 4 feet/second in an 8-pound walker (1996 ASTM Working Group) and in a 10.5-pound walker (2000 Austrian study<sup>4</sup>). (Both of these studies were based on small sample sizes of 7 and 5 children, respectively.) Stair fall incidents continue to occur, and some involve modern walkers that meet the ASTM requirements. Since the child/walker speed is the critical factor in

determining stopping distance of a moving walker at the edge of the step, CPSC staff believes that a 4 feet/second velocity should be maintained regardless of the walker's weight. This necessitates using the walker's actual weight in the calculation for the stair fall test.

With regard to incident data supporting the change, a special study conducted by CPSC indicates that several reported incidents involved walkers that were manufactured to comply with the ASTM stair step requirement and were reported to have been in good condition at the time of the incident. In addition, a review of a list compiled by CPSC staff of over 200 incidents (reported through sources other than NEISS) involving infant walkers from 1999 to 2008 indicates that over 40 percent of those incidents involved stair falls, including one death which occurred due to a fractured skull.

CPSC staff's review of the data has also shown that popular larger, heavier models (greater than 8 pounds) manufactured after 1998 were involved in stair falls. For example, in incident 081112HEP9038, a 10-month old male fell down a set of steps when he traveled past an unlatched gate; the child required a trip to the emergency room. In incident 081113HEP9029, an 11-month old male fell down a set of stairs and was found upside down still in the walker. Both incidents involved walkers made by a leading manufacturer. Both incidents occurred from 2007 to 2008, and both walkers were equipped with friction strips. Therefore, the data show that modern walkers continue to be involved in stair fall incidents. If a walker is traveling too fast, even if it is equipped with friction strips, it may fall down a set of steps. By increasing this launching distance, the Commission is making the standard stricter, which should result in walkers that are made to be safer when traveling at faster speeds.

## 4. Impact of Change to Step Test

*Comment:* The same commenter stated that using a calculation in the step test would be a substantial change and would affect the outcome of the test results for walkers that pass the requirement.

*Response:* Based on limited testing by CPSC staff, the Commission believes that some manufacturers will not need to make changes to their product. CPSC staff agrees that some manufacturers will have to modify their product. However, these changes are feasible. Possible modifications could include increasing the rolling friction within the walker's wheels, reducing the walker

<sup>4</sup>"Baby Walking Frames—Final Report," Consumer Council Austrian Standards Institute in co-operation with Association for Consumer Information, European Committee For Standardization, CEN/TC 252/WG 1 N. 255 February 2001.

weight, or refining the friction strip design.

#### 5. CAMI Dummy Head Position

*Comment:* One commenter requested CPSC to consider specifying how the CAMI dummy is to “be positioned and restrained during testing so that the center of gravity will be consistent from lab to lab.”

*Response:* CPSC agrees in principle that it is plausible that a CAMI dummy’s flexibility properties may change over time and use. Last year, round robin testing was done by CPSC staff, several manufacturers, and a testing laboratory. In addition to pass/fail testing, quantitative measurements were made, measuring the displacement of the walker relative to the edge of the test table. Testing done by CPSC staff did not show any substantial variability in the CPSC test results when the CAMI dummy’s head was not secured. However, many other parameters, such as rope type, pulley type, and the spring rate for the pulley mounting bracket, were standardized. Furthermore, the CPSC standard provides additional specificity concerning the CAMI positioning: arms positioned on top of the toy tray, use of the standardized military rope to secure the legs, *etc.* Securing the CAMI head in a most rearward or forward position could possibly produce different results, depending on the flexibility of the dummy. Thus, CPSC staff believes that the CAMI head should not be secured. When the CAMI is positioned as described in the proposed (and final) procedure, the CAMI head movement, while it exists, is minimized to the extent possible. Thus, the final rule, like the proposed rule, provides for the CAMI head to remain unrestrained during all the step tests.

#### 6. Friction Pad Wear and Tear

*Comment:* The same commenter asked the CPSC to consider the affect of wear and tear as well as dirt and dust on the walker’s compliance with the step test.

*Response:* The final rule does not include any additional performance requirements involving step tests with worn friction strips. Although CPSC recognizes that friction pad wear may reduce the pad’s effectiveness, this may not be the case for all walker friction pads. Some pads may last longer than others. Assessing the amount of wear and standardizing the wear characteristics may be somewhat subjective. Given the variation between friction pad vendors and the changing compositions of the rubber used in the friction pads, it may be difficult to

standardize this aspect of the test. The final standard includes other changes that address the stair fall hazard, such as increasing the input kinetic energy for heavier walkers (*i.e.*, walkers heavier than 8 pounds would need to be launched from a longer distance to achieve the target terminal velocities). In an indirect way, setting the higher input kinetic energy requirement for heavier walkers creates revised design criteria for walker manufacturers. One area where those manufacturers can address the resistance to stair falls may lie in revisions to the friction pad design. CPSC staff believes standardizing the target velocity will have an important impact on the actual test, as the kinetic energy of the walker and CAMI dummy is proportional to the square of the velocity. Furthermore, each walker will be subjected to 18 impacts which will sufficiently subject the sample walkers to abuse (3 directions  $\times$  2 configurations with and without vest  $\times$  3 replicates). For these reasons, CPSC staff believes there is insufficient data and rationale to add performance requirements involving stair fall tests with worn friction strips.

### F. Assessment of Voluntary Standard ASTM F 977–07 and Description of Final Rule

#### 1. Section 104(b) of the CPSIA: Consultation and CPSC Staff Review

Section 104(b) of the CPSIA requires the Commission to assess the effectiveness of the voluntary standard in consultation with representatives of consumer groups, juvenile product manufacturers, and other experts. This consultation process began in October 2008 during the ASTM subcommittee meeting regarding the ASTM infant walker voluntary standard. Consultations between Commission staff and members of this subcommittee have continued and are still ongoing.

As discussed in the preamble to the proposed rule (74 FR at 45706), CPSC staff conducted testing on JPMA certified walkers in order to evaluate the ASTM infant walker standard and develop recommendations for changes to it. The testing focused on the stair fall test in the ASTM standard, a stability performance requirement, and a parking brake requirement (the latter two both taken from EN 1273:2005).

Consistent with section 104(b) of the CPSIA, this rule establishes a new 16 CFR part 1216, “Safety Standard for Infant Walkers.” The new part incorporates by reference the requirements for infant walkers in ASTM F 977–07 with certain changes to specific provisions to strengthen the

ASTM standard, as discussed in the next section of this preamble, to further reduce the risk of injury. These modifications are similar to the changes the Commission proposed in its September 3, 2009 proposed rule. Differences from the proposed rule are noted in the following section of this preamble.

#### 2. Description of Final Rule Including Changes to the ASTM Standard’s Requirements

While most requirements of the ASTM F 977–07 standard are sufficient to reduce the risk of injury posed by infant walkers, the Commission has modified several provisions in the standard to make them more stringent and clarified the test procedures. The following discussion describes the final rule, including changes to the ASTM requirements, and notes any changes from the proposed rule. In addition, some editing and formatting changes have been made which make the final text different from the proposed rule. The Commission made these editing and formatting changes to respond to concerns raised by the Office of the Federal Register; the editing and formatting changes do not alter the substance of the rule.

##### a. Scope (§ 1216.1)

The final rule states that part 1216 establishes a consumer product safety standard for infant walkers manufactured or imported on or after a date which would be six months after the date of publication of a final rule in the **Federal Register**.

The Commission received no comments on this provision in the proposed rule and is finalizing it without change.

##### b. Incorporation by Reference (§ 1216.2(a))

Section 1216.2(a) explains that, except as provided in § 1216.2(b), each infant walker must comply with all applicable provisions of ASTM F 977–07, “Standard Consumer Safety Specification for Infant Walkers,” which is incorporated by reference. Section 1216.2(a) also provides information on how to obtain a copy of the ASTM standard or to inspect a copy of the standard at the CPSC.

The Commission received no comments on this provision in the proposed rule and is finalizing it without change.

##### c. Summary of Changes to ASTM F 977–07

The more substantive modifications to the ASTM standard for walkers are

discussed in greater detail in part F.2.d. of this preamble below. A summary of these changes along with the other, more editorial/technical changes that the rule makes to the ASTM standard follows. The final rule:

- Updates the illustration of types of models of walkers in Figure 1 of the ASTM standard to include an open back design (§ 1216.2(b)(1));
- Revises equipment specifications in section 4.6 of the ASTM standard to eliminate brand and model of force gauge and provide performance specifications instead. The proposed rule would have a one year calibration interval. However, the final rule provides a more general interval because a force gauge could go out of calibration before one year. Appropriate calibrations are necessary to maintain accuracy. (§ 1216.2(b)(2));
- Revises Figure 10 of the ASTM standard to show specific rope, other equipment and procedures for the step test (§ 1216.2(b)(15));
- In step test procedures, adds a calculation (discussed below) using the actual weight of the walker to determine the launching distance rather than assuming an 8-pound walker. (§ 1216.2(b)(5)(i), (6)(i), (8)(i), (9)(i)(11), (13)(i), (16)(i), (18)(i));
- In step test procedures, specifies the position for walker wheels (§ 1216.2(b)(6)(i), (11)(i), (16)(i));
- In step test procedures, specifies the position for the CAMI dummy. (§ 1216.2(b)(7)(i));
- In step test procedures, specifies rope type, pulley type, and force to be applied. (§ 1216.2(b)(4)(i), (8)(i), (12)(i), (17)(i));
- In step test procedures, requires each aspect of the test (forward, sideward, and rearward) three times to make it consistent with EN 1273:2005 and allow more confidence in the test results. (§ 1216.2(b)(10)(i), (14)(i), (19)(i));
- Adds the following warning concerning the parking brake if a walker has a parking brake: “WARNING: Parking brake use does not totally prevent walker movement. Always keep child in view when in the walker, even when using the parking brakes.” (§ 1216.2(b)(21)(i));
- Revises the stair hazard warning to state: “Block stairs/steps securely before using walker, even when using parking brake.” (§ 1216.2(b)(22)(i)); and
- Adds parking device test (§ 1216.2(b)(20)).

d. More Detailed Description of Changes to the ASTM Standard’s Step Test

*Specification of equipment and procedures.* The ASTM F 977–07

standard’s step test lacks numerous details which allow for variability in testing that could result in different test results. The Commission proposed specifying the equipment and procedure needed for the test (e.g., type of rope and pulley to be used, orientation of wood grain in the floor). The final rule retains these changes. Additionally, the Commission proposed modifying the test procedure language in several provisions, such as specifying a tolerance for the term “horizontal” ( $0^\circ \pm 0.5^\circ$ ). The final rule retains these changes.

The final rule removes a specification that the test table be 48 inches. This specification appears in a notation in Figure 10 of the ASTM standard. The proposed rule showed figure 10 with the noted 48-inch length table. However, the final rule leaves the length of the test table unspecified so that a test laboratory may use a table of adequate length to accommodate the maximum calculated launching distance d. A test table length of 48 inches may not be sufficient for all walkers once the calculation is based on the actual weight of the walker.

*Calculation of launching distance.* The Commission proposed a change in the calculation of the launching distance used in the step test. The Commission proposed weighing the walker and computing the appropriate launching distances using the actual weight of the walker.

As discussed in the preamble to the proposed rule (74 FR at 45704) and in this preamble, the launching distances may vary depending on the weight of the walker and the maximum velocity of the walker at the edge of the platform (4 ft/sec or 2 ft/sec). If the walker weight is not appropriately accounted for, then it is possible the target maximum velocity cannot be achieved. For example, if the scenario involved computing distance d where the walker is tested in the forward direction with the CAMI dummy and the walker weight is 14 pounds, distance d would equal 18.0 inches (instead of 14.6 inches if the walker weight value is 8 pounds). The longer distance is needed to achieve the target velocity of 4 feet/second. If a 14-pound walker is launched from 14.6 inches, the walker may not achieve the maximum velocity of 4 feet/second. The final rule retains the distance d calculation with a slight modification that requires the testing lab to measure the weight of the CAMI dummy and vest. This will account for variations in the weight of CAMI dummies and vests.

e. More Detailed Description of Parking Brake Test

The Commission proposed adding the parking brake test of the European Standard EN 1273:2005. The final rule retains this test. It applies to infant walkers that provide parking brakes, but it does not require walkers to have parking brakes. Under this test, the walker is set up to run a quasi-static version of the step test, but with the parking device activated. If the walker moves a distance greater than 1.97 inches (50 mm), the walker fails the requirement. The parking brake test will ensure that, if a walker has a parking brake, it will work effectively.

f. Elimination of 30° Incline Plane Test

The Commission proposed adding the 30° incline plane test from the European Standard EN 1273:2005 for walkers. As discussed more fully in the response to a comment in part E of this preamble, the final rule eliminates this additional requirement because testing and analysis by a JPMA member demonstrated the adequacy of the stability test in the ASTM F 977–07 standard.

#### G. Effective Date

The Commission proposed that the standard would become effective 6 months after publication of a final rule. The Commission received no comments on the proposed effective date. The final rule provides that the rule will become effective six months after publication and thus will require that infant walkers manufactured or imported on or after that date must meet this standard.

#### H. Paperwork Reduction Act

Sections 8 and 9 of ASTM F 977–07 contain requirements for marking, labeling and instructional literature that are considered “information collection requirements” under the Paperwork Reduction Act, 44 U.S.C. 3501–3520. In a separate notice elsewhere in this issue of the **Federal Register**, the Commission is publishing a notice requesting comments on this collection of information.

#### I. Regulatory Flexibility Act

The Regulatory Flexibility Act (“RFA”) generally requires that agencies review rules for their potential economic impact on small entities, including small businesses. 5 U.S.C. 604.

##### 1. The Market

There are currently at least seven manufacturers or importers supplying infant walkers to the United States market (four domestic manufacturers,

two foreign manufacturers with divisions in the United States, and one domestic importer). Under Small Business Administration (SBA) guidelines, a manufacturer of infant walkers is small if it has 500 or fewer employees and an importer is considered small if it has 100 or fewer employees. Two domestic manufacturers (a third small manufacturer also sells infant walkers, but based on their current product list is no longer manufacturing them) and one domestic importer known to be supplying the United States market qualify as small businesses under these guidelines. However, CPSC staff believes that there are probably other unknown small importers operating in the United States market as well.

All domestic manufacturers supplying infant walkers to the United States market certify their products as compliant with the ASTM voluntary standard through the JPMA certification program. Based on limited CPSC staff testing, the two foreign manufacturers and the domestic importer are not believed to be complying with the voluntary standard.

## 2. Impact of the Rule

The changes to the existing stair fall test requirements would reduce variability across manufacturers. Also, because the specific test modifications have been selected to minimize the friction associated with the test procedure, they may effectively add stringency to the tests. It is unknown the extent (if any) to which the modification in the existing stair fall requirements of the voluntary standard will affect infant walkers that now comply with the voluntary standard. However, initial testing shows that the requirements impact the test results of a few walkers. Therefore, it is possible that some manufacturers might need to make walker modifications to comply. Based on staff estimates of the costs of complying with the 1997 stair fall requirements, this cost is unlikely to exceed more than several dollars per unit. Possible modifications include: Increasing the rolling friction within the walker's wheels; reducing the walker weight; and refining the friction strip design.

Infant walkers are not currently required to have parking brakes, nor would they be required to have them under the standard. However, the final rule includes a test of parking brakes, if a walker has them, to assure that they work properly. Initial testing finds that existing walkers have no difficulty in passing this requirement. Therefore, the Commission does not expect it to

represent a burden to current manufacturers. However, its inclusion would minimize the risk of walkers with ineffective brakes entering the United States market in the future.

Of the seven firms currently known to be marketing infant walkers in the United States, three are small firms—two small domestic manufacturers and a small domestic importer. We discuss the possible impact of the rule on these entities immediately below.

*Small manufacturers.* One small domestic manufacturer has annual sales of approximately \$31–72.5 million. It currently produces seven walker models and approximately 57 other juvenile products, one of which is a substitute for infant walkers. The second is a small domestic manufacturer with annual sales of approximately \$2.5–5 million. Although its annual sales are lower, it is currently producing only one infant walker model and approximately 110 other juvenile products.

The two small domestic manufacturers (which are JPMA certified as compliant with the voluntary standard) may not need to make product modifications. If they do, it will most likely be due to changes needed to comply with the modified stair fall requirements. The costs to these manufacturers are not likely to be substantial, but may increase by as much as several dollars per unit.

*Small importers.* The only known small domestic importer has annual sales of approximately \$2.5–5 million and is not believed to be in compliance with the voluntary standard. Therefore, some product modifications would be necessary. The impact of the infant walker requirements on this importer is unclear, because little is known about the walkers sold by this company. However, the impact is unlikely to be large. Even if the company responded to the rule by discontinuing the import of its non-complying walkers, either replacing them with a complying product or another juvenile product, deciding to import an alternative product would be a reasonable and realistic way to offset any lost revenue from walker sales.

There also may be additional importers of walkers that the staff has been unable to identify. However, the impacts of the rule on these firms, if any, are unknown.

## 3. Alternatives

Under section 104 of the CPSIA, the primary alternative that would reduce the impact on small entities is to make the voluntary standard mandatory with no modifications. Because the two small domestic manufacturers already meet

the requirements of the voluntary standard, adopting the standard without modifications may reduce their costs, but only marginally. Similarly, limiting the requirements of the standard to those already contained in the voluntary standard would probably have little beneficial impact on small importers that do not currently meet the requirements of the voluntary standard. This is because, to these firms, most of the infant walker cost increases would be associated with meeting the requirements of the voluntary standard, rather than the minor additions associated with the Commission's modification of the standard.

## 4. Conclusion of Final Regulatory Flexibility Analysis

It is not expected that the standard will have a substantial effect on a large number of small firms. In some cases, small firms may not need to make any product modifications to achieve compliance. Even if modifications were necessary, and the cost of developing a compliant product proved to be a barrier for individual firms, the loss of infant walkers as a product category is expected to be minor and would likely be mitigated by increased sales of competing products, such as activity centers, or entirely different juvenile products.

## J. Environmental Considerations

The Commission's regulations provide a categorical exclusion for the Commission's rules from any requirement to prepare an environmental assessment or an environmental impact statement as they "have little or no potential for affecting the human environment." 16 CFR 1021.5(c)(1). This rule falls within the categorical exclusion.

## K. Preemption

Section 26(a) of the CPSA, 15 U.S.C. 2075(a), provides that where a "consumer product safety standard under [the CPSA]" is in effect and applies to a product, no State or political subdivision of a State may either establish or continue in effect a requirement dealing with the same risk of injury unless the State requirement is identical to the Federal standard. (Section 26(c) of the CPSA also provides that States or political subdivisions of States may apply to the Commission for an exemption from this preemption under certain circumstances.) Section 104(b) of the CPSIA refers to the rules to be issued under that section as "consumer product safety rules," thus implying that the preemptive effect of section 26(a) of the CPSA would apply.

Therefore, a rule issued under section 104 of the CPSIA will invoke the preemptive effect of section 26(a) of the CPSA when it becomes effective.

#### L. Certification

Section 14(a) of the Consumer Product Safety Act (“CPSA”) imposes the requirement that products subject to a consumer product safety rule under the CPSA, or to a similar rule, ban, standard, or regulation under any other act enforced by the Commission, must be certified as complying with all applicable CPSC requirements. 15 U.S.C. 2063(a). Such certification must be based on a test of each product or on a reasonable testing program or, for children’s products, on tests on a sufficient number of samples by a third party conformity assessment body accredited by the Commission to test according to the applicable requirements. As discussed above in part K of this preamble, section 104(b)(1)(B) of the CPSIA refers to standards issued under that section, such as the rule for infant walkers established in this final rule, as “consumer product safety standards.” By the same reasoning, such standards also would be subject to section 14 of the CPSA. Therefore, any such standard would be considered to be a consumer product safety rule to which products subject to the rule must be certified.

Because infant walkers are children’s products, they must be tested by a third party conformity assessment body

whose accreditation has been accepted by the Commission. The Commission is issuing a separate notice of requirements to explain how laboratories can become accredited as third party conformity assessment bodies to test to the new safety standard. (Infant walkers also must comply with all other applicable CPSC requirements, such as the lead content requirements of section 101 of the CPSIA, potentially the phthalate content requirements in section 108 of the CPSIA if the walker incorporates a toy component, the tracking label requirement in section 14(a)(5) of the CPSA, and the consumer registration form requirements in section 104 of the CPSIA.)

#### List of Subjects in 16 CFR 1216

Consumer protection, Incorporation by reference, Imports, Infants and children, Labeling, Law enforcement, and Toys.

■ Therefore, the Commission amends Title 16 of the Code of Federal Regulations by adding part 1216 to read as follows:

#### PART 1216—SAFETY STANDARD FOR INFANT WALKERS

Sec.

1216.1 Scope.

1216.2 Requirements for infant walkers.

**Authority:** The Consumer Product Safety Improvement Act of 2008, Pub. L. 110–314, § 104, 122 Stat. 3016 (August 14, 2008).

#### § 1216.1 Scope.

This part 1216 establishes a consumer product safety standard for infant walkers manufactured or imported on or after December 21, 2010.

#### § 1216.2 Requirements for infant walkers.

(a) Except as provided in paragraph (b) of this section, each infant walker shall comply with all applicable provisions of ASTM F 977–07, Standard Consumer Safety Specification for Infant Walkers, approved April 1, 2007. The Director of the Federal Register approves this incorporation by reference in accordance with 5 U.S.C. 552(a) and 1 CFR part 51. You may obtain a copy from ASTM International, 100 Bar Harbor Drive, P.O. Box 0700, West Conshohocken, PA 19428; telephone 610–832–9585; <http://www.astm.org>. You may inspect a copy at the Office of the Secretary, U.S. Consumer Product Safety Commission, Room 820, 4330 East West Highway, Bethesda, MD 20814, telephone 301–504–7923, or at the National Archives and Records Administration (NARA). For information on the availability of this material at NARA, call 202–741–6030, or go to: [http://www.archives.gov/federal\\_register/code\\_of\\_federal\\_regulations/ibr\\_locations.html](http://www.archives.gov/federal_register/code_of_federal_regulations/ibr_locations.html).

(b) Comply with the ASTM F 977–07 standard with the following additions or exclusions:

(1) Instead of Figure 1 of ASTM F 977–07, comply with the following:

**BILLING CODE 6355–01–P**



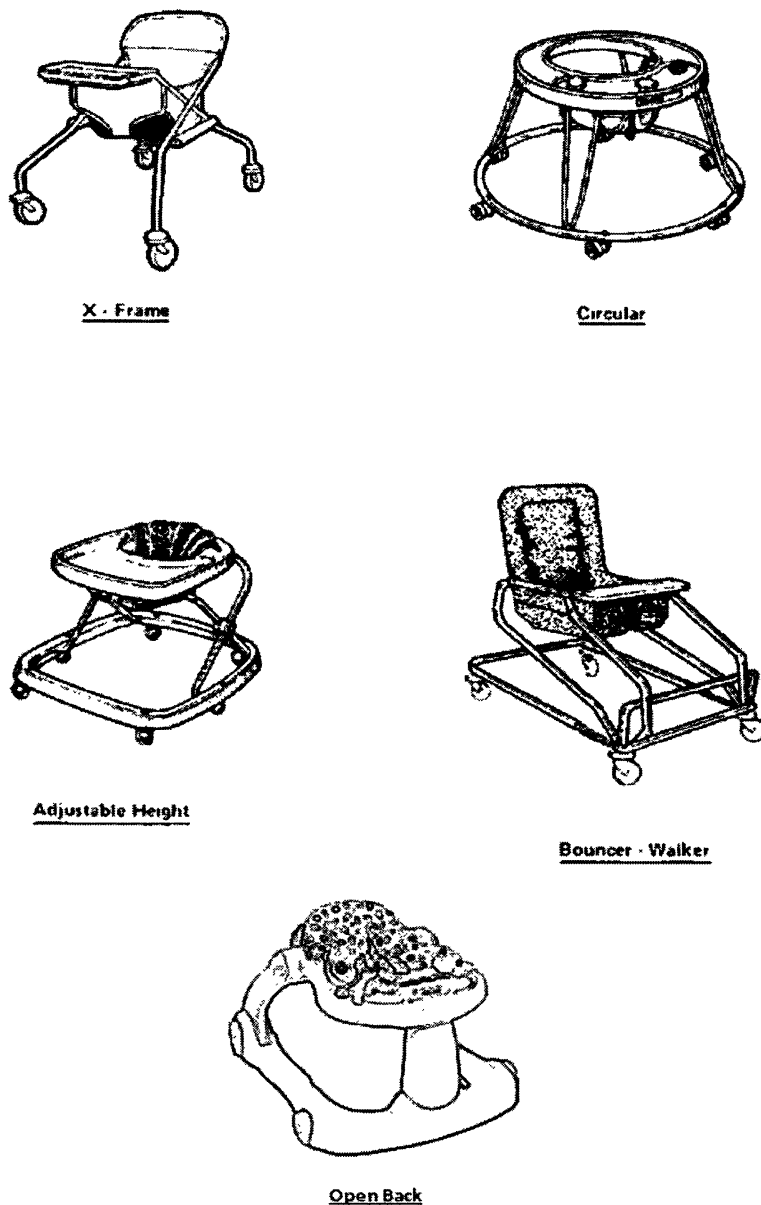

**Figure 1 Illustration of Types of Infant Walkers**

**BILLING CODE 6355-01-C**

(2) Instead of complying with section 4.6 through 4.6.8 of ASTM F 977-07, comply with the following:

(i) 4.6 The following guidelines shall apply to force gauges used for testing:

(ii) 4.6.1 *Equipment*—Force gauge with a range of 0 to 25 lbf (110 N), tolerance of  $\pm 0.25$  lbf (1.1 N). A calibration interval shall be maintained for the force gauge which will ensure

that the accuracy does not drift beyond the stated tolerance.

(iii) 4.6.2 *Equipment*—Force gauge with a range 0 to 100 lbf (500 N) tolerance of  $\pm 1$  lbf (4.44 N). A calibration shall be maintained for the force gauge which will ensure that the accuracy does not drift beyond the stated tolerance.

(3) In addition to complying with section 6.3 of ASTM F 977-07, comply with the following:

(i) 6.4 *Parking Device (applicable to walkers equipped with parking brakes)*—The walker shall have a maximum displacement of 1.97 inches (50 mm) for each test in each direction (forward, rearward, and sideward) when tested in accordance with 7.7.

(ii) [Reserved]

(4) In addition to complying with section 7.6.1.2 of ASTM F 977-07, comply with the following:

(i) 7.6.1.2 The dummy's head shall remain unrestrained for all the step tests.

(5) Following section 7.6.2 of ASTM F 977-07, use the following table instead of Table 1 Summary of Step(s) Tests:

(ii) [Reserved]

(i) Table 1 Summary of Step(s) Tests

Section No.	Facing direction of walker	Weight of CAMI dummy, lb.	Simulated speed, ft/s	Apply tipover test
7.6.3	Forward	17	4	Yes.
7.6.3.6	Forward	28 (vest)	4	Yes.
7.6.4	Sideward	17	2	Yes.
7.6.4.6	Sideward	28 (vest)	2	Yes.
7.6.5	Rearward	17	4	No.
7.6.5.5	Rearward	28 (vest)	4	No.

(ii) [Reserved]  
 (6) Instead of complying with section 7.6.3.1 of ASTM F 977-07, comply with the following:

(i) 7.6.3.1 Center the walker on the test platform facing forward so that Plane A is perpendicular to the front edge of the platform and the walker is

distance *d* from the center of the most forward wheel(s) to the edge of the test platform,

$$d_{CAMI} = \frac{(V_f^2 - V_o^2) * (W_{CAMI} + W_{walker} + W_{drop\ weight})}{2g(W_{drop\ weight} - \mu_k N_{CAMI})}$$

Where

$V_f$  = Maximum velocity of walker at edge of platform = 4 ft/sec

$V_o$  = Initial velocity = 0

$W_{CAMI}$  = Measured weight of CAMI dummy

$W_{walker}$  = Weight of the walker

$W_{drop\ weight}$  = Drop weight = 8 lb

$\mu_k$  = Dynamic coefficient of friction = 0.05

$N_{CAMI}$  = Normal force (for CAMI dummy scenario) = weight of CAMI dummy and walker

$g$  = acceleration of gravity = 32.2 ft/sec<sup>2</sup>

Position the swivel wheels in such a way that the walker moves forward in a straight line parallel to Plane A.

(ii) [Reserved]

(7) Instead of complying with section 7.6.3.2 of ASTM F 977-07, comply with the following:

(i) 7.6.3.2 Place a CAMI infant dummy Mark II in the walker and position it as shown in Fig. 11 with the torso contacting the front of the occupant seating area and arms placed on the walker tray.

(ii) [Reserved]

(8) Instead of complying with section 7.6.3.3 of ASTM F 977-07, comply with the following:

(i) 7.6.3.3 While holding the walker stationary, attach an 8 lb (3.6 kg) weight to the front of the walker base at Plane A by

means of a 7-strand military rope with 550 lb tensile strength (e.g., paracord 550) and a stainless steel ball bearing pulley with an outside diameter of 1.25 in (32mm) and adjust the pulley so that the force is applied horizontally ( $0 \pm 0.5^\circ$  with respect to the table surface).

(ii) [Reserved]

(9) Instead of complying with section 7.6.3.6 of ASTM F 977-07, comply with the following:

(i) 7.6.3.6 Repeat 7.6.3.1-7.6.3.5 using the CAMI dummy with the weighted vest and with distance *d*, computed using the following equation:

$$d_{CAMI\ w/vest} = \frac{(V_f^2 - V_o^2) * (W_{CAMI\ w/vest} + W_{walker} + W_{drop\ weight})}{2g(W_{drop\ weight} - \mu_k N_{CAMI\ w/vest})}$$

Where

$V_f$  = Maximum velocity of walker at edge of platform = 4 ft/sec

$V_o$  = Initial velocity = 0

$W_{CAMI\ w/vest}$  = Measured weight of CAMI dummy and weighted vest

$W_{walker}$  = Weight of the walker

$W_{drop\ weight}$  = Drop weight = 8 lb

$\mu_k$  = Dynamic coefficient of friction = 0.05

$N_{CAMI\ w/vest}$  = Normal force (for CAMI dummy fitted with 11 lb vest scenario) = weight

of CAMI dummy + vest weight + walker weight

$g$  = acceleration of gravity = 32.2 ft/sec<sup>2</sup>

(ii) [Reserved]

(10) In addition to complying with section 7.6.3.6 of ASTM F 977-07, comply with the following:

(i) 7.6.3.7 Repeat tests in the following sequence: Section 7.6.3.4, section 7.6.3.5, and section 7.6.3.6 two additional times.

(ii) [Reserved]

(11) Instead of complying with 7.6.4.1 of ASTM F 977-07, comply with the following:

(i) 7.6.4.1 Center the walker on the test platform facing sideways so that Plane B is perpendicular to the front edge of the platform and the walker is distance *d* from the center of the most sideward wheel(s) to the edge of the test platform,

$$d_{CAMI} = \frac{(V_f^2 - V_o^2) * (W_{CAMI} + W_{walker} + W_{drop\ weight})}{2g(W_{drop\ weight} - \mu_k N_{CAMI})}$$

Where

$V_f$  = Maximum velocity of walker at edge of platform = 2 ft/sec

$V_o$  = Initial velocity = 0

$W_{CAMI}$  = Measured weight of CAMI dummy

$W_{walker}$  = Weight of the walker

$W_{drop\ weight}$  = Drop weight = 8 lb

$\mu_k$  = Dynamic coefficient of friction = 0.05

$N_{CAMI}$  = Normal force (for CAMI dummy scenario) = weight of CAMI dummy and walker

$g$  = acceleration of gravity = 32.2 ft/sec<sup>2</sup>

Position the swivel wheels in such a way that the walker moves sideward in a straight line parallel to Plane A.

(ii) [Reserved]

(12) Instead of complying with section 7.6.4.3 of ASTM F 977-07, comply with the following:

(i) 7.6.4.3 While holding the walker stationary, attach an 8 lb (3.6 kg) weight to the side of the walker base at Plane B by means of a rope (as specified in 7.6.3.3) and a pulley (as specified in

7.6.3.3) and adjust the pulley so that the force is applied horizontally ( $0 \pm 0.5^\circ$  with respect to the table surface).

(ii) [Reserved]

(13) Instead of complying with section 7.6.4.6 of ASTM F 977-07, comply with the following:

(i) 7.6.4.6 Repeat 7.6.4.1 through 7.6.4.5 using the CAMI dummy with the weighted vest (see Fig. 12) and with distance  $d$ , computed using the following equation:

$$d_{CAMI\ w/vest} = \frac{(V_f^2 - V_o^2) * (W_{CAMI\ w/vest} + W_{walker} + W_{drop\ weight})}{2g(W_{drop\ weight} - \mu_k N_{CAMI\ w/vest})}$$

Where

$V_f$  = Maximum velocity of walker at edge of platform = 2 ft/sec

$V_o$  = Initial velocity = 0

$W_{CAMI\ w/vest}$  = Measured weight of CAMI dummy and weighted vest

$W_{walker}$  = Weight of the walker

$W_{drop\ weight}$  = Drop weight = 8 lb

$\mu_k$  = Dynamic coefficient of friction = 0.05

$N_{CAMI\ w/vest}$  = Normal force (for CAMI dummy fitted with 11 lb vest scenario) = weight of CAMI dummy + vest weight + walker weight

$g$  = acceleration of gravity = 32.2 ft/sec<sup>2</sup>

(ii) [Reserved]

(14) In addition to complying with section 7.6.4.6 of ASTM F 977-07, comply with the following:

(i) 7.6.4.7 Repeat tests in the following sequence: section 7.6.4.4, section 7.6.4.5, and section 7.6.4.6 two additional times.

(ii) [Reserved]

(15) Instead of complying with Figure 10, use the following:

**BILLING CODE 6355-01-P**

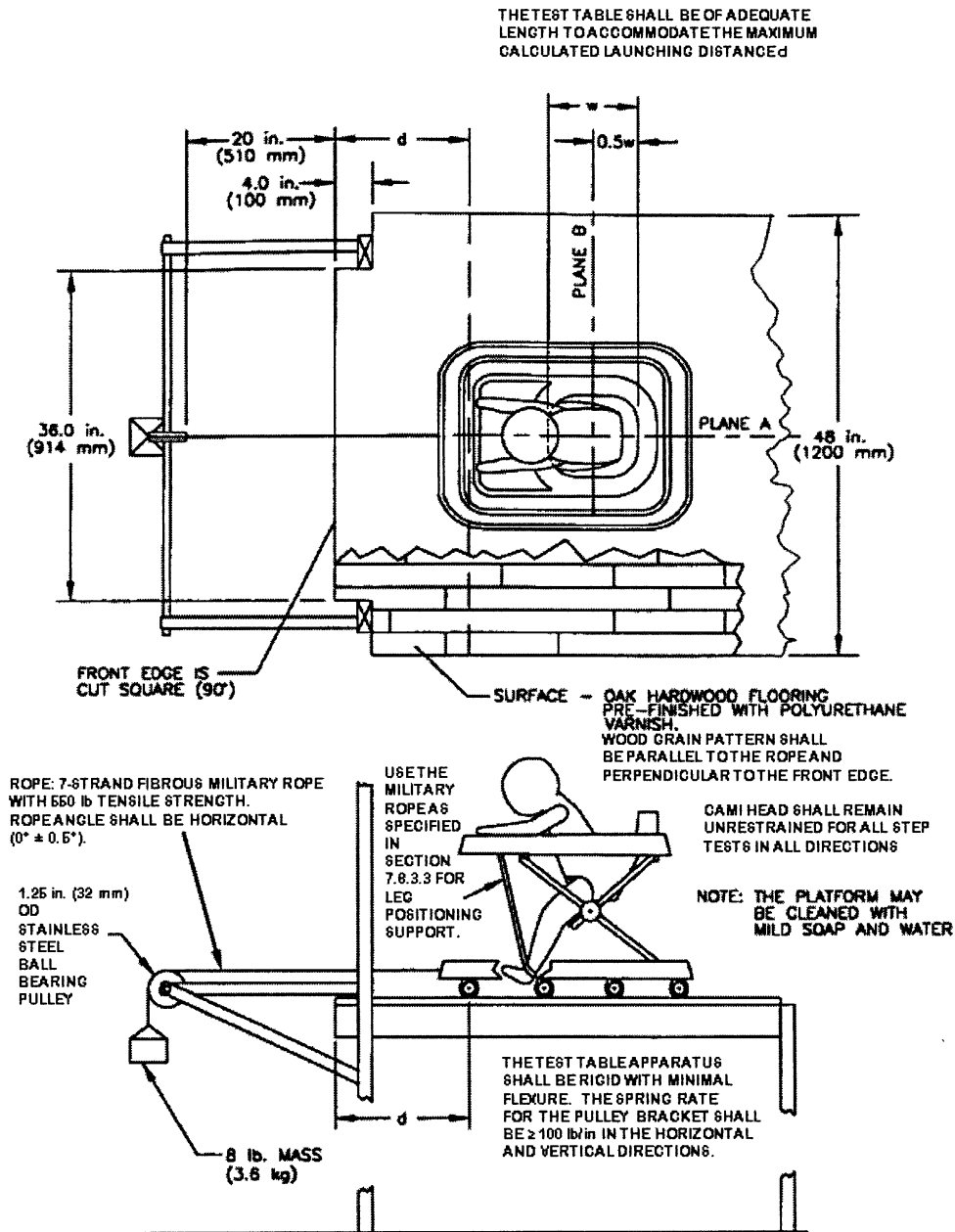

**Figure 10 Test Platform Specifications**

BILLING CODE 6355-01-C

(16) Instead of complying with section 7.6.5.1 of ASTM F 977-07, comply with the following:

(i) 7.6.5.1 Center the walker on the test platform facing rearward so that Plane A is perpendicular to the front edge of the platform and the walker is

distance *d* from the center of the most rearward wheel(s) to the edge of the test platform,

$$d_{CAMI} = \frac{(V_f^2 - V_o^2) * (W_{CAMI} + W_{walker} + W_{drop\ weight})}{2g(W_{drop\ weight} - \mu_k N_{CAMI})}$$

Where

$V_f$  = Maximum velocity of walker at edge of platform = 4 ft/sec

$V_o$  = Initial velocity = 0

$W_{CAMI}$  = Measured weight of CAMI dummy

$W_{walker}$  = Weight of the walker

$W_{drop\ weight}$  = Drop weight = 8 lb

$\mu_k$  = Dynamic coefficient of friction = 0.05

$N_{CAMI}$  = Normal force (for CAMI dummy scenario) = weight of CAMI dummy and walker

$g$  = acceleration of gravity = 32.2 ft/sec<sup>2</sup>

Position the swivel wheels in such a way that the walker moves rearward in

a straight line parallel to Plane A. If the walker has an open back design, attach the 1 in aluminum angle used in 7.3.4 to span the back frame.

(ii) [Reserved]

(17) Instead of complying with section 7.6.5.3 of ASTM F 977–07, comply with the following:

(i) 7.6.5.3 While holding the walker stationary, attach an 8 lb (3.6 kg) weight to the rear of the walker base at Plane A by means of a rope (as specified in 7.6.3.3) and a pulley (as specified in

7.6.3.3) and adjust the pulley so that the force is applied horizontally ( $0 \pm 0.5^\circ$  with respect to the table surface).

(ii) [Reserved]

(18) Instead of complying with section 7.6.5.5 of ASTM F 977–07, comply with the following:

(i) 7.6.5.5 Repeat 7.6.5.1 through 7.6.5.4 using the CAMI dummy with the weighted vest (see Fig. 12) and with distance  $d$ , computed using the following equation:

$$d_{CAMI\ w/vest} = \frac{(V_f^2 - V_o^2) * (W_{CAMI\ w/vest} + W_{walker} + W_{drop\ weight})}{2g(W_{drop\ weight} - \mu_k N_{CAMI\ w/vest})}$$

Where

$V_f$  = Maximum velocity of walker at edge of platform = 4 ft/sec

$V_o$  = Initial velocity = 0

$W_{CAMI\ w/vest}$  = Measured weight of CAMI dummy and weighted vest

$W_{walker}$  = Weight of the walker

$W_{drop\ weight}$  = Drop weight = 8 lb

$\mu_k$  = Dynamic coefficient of friction = 0.05

$N_{CAMI\ w/vest}$  = Normal force (for CAMI dummy fitted with weighted vest scenario) = Measured weight of CAMI dummy + measured weight of vest + walker weight

$g$  = acceleration of gravity = 32.2 ft/sec<sup>2</sup>

(19) In addition to complying with section 7.6.5.5 of ASTM F 977–07, comply with the following:

(i) 7.6.5.6 Repeat tests in the following sequence: section 7.6.5.3, and section 7.6.5.5 two additional times.

(ii) [Reserved]

(20) In addition to complying with section 7.6 of ASTM F 977–07, comply with the following:

(i) 7.7 *Parking Device Test* (see 6.4):

(A) 7.7.1 Perform the parking device test using a Test Mass that is A rigid cylinder 6.30 in  $\pm$  0.04 in (160mm  $\pm$  1 mm) in diameter, 11.02 in  $\pm$  0.04 in (280 mm  $\pm$  1 mm) in height with a mass of 16.9 lb (7.65 kg), with its center of gravity in the center of the cylinder.

(B) 7.7.2 Adjust the walker seat to the highest position (if applicable). Place the Test Mass vertically in the walker seat. Set any manual speed control to the fastest position (if applicable). Establish a vertical plane A that passes through the center of the seating area and is parallel to the direction the child faces. Establish a vertical plane B that is perpendicular to plane A and passes through the center of the seating area.

(C) 7.7.3 Perform the parking device test in the forward, sideward, and rearward directions.

(D) 7.7.4 *Forward facing test of parking devices.*

(E) 7.7.4.1 Position the walker including the Test Mass facing forward so that plane A is perpendicular to the front edge of the platform (see fig. 10) and passes through the center of the pulley. Engage all parking devices in accordance with the manufacturer's instructions.

(F) 7.7.4.2 Within one minute of placing the walker with the Test Mass on the platform, attach an 8 lb weight gradually within 5 seconds to the walker frame base at plane A by means of a rope and a pulley per the test apparatus specifications in the step test procedure, adjusted so that the force is applied horizontally (rope angle shall be  $0 \pm 0.5^\circ$ ). Remove the 8 lb weight after 1 minute. Measure the displacement.

(G) 7.7.5 *Sideward facing test of parking devices.*

(H) 7.7.5.1 Position the walker including the Test Mass facing sideward so that plane B is perpendicular to the front edge of the platform and passes through the center of the pulley. Engage all parking devices in accordance with the manufacturer's instructions.

(I) 7.7.5.2 Within one minute of placing the walker with the Test Mass on the platform, attach an 8 lb weight gradually within 5 seconds to the walker frame base at plane B by means of a rope and a pulley per the test apparatus specifications in the step test procedure, adjusted so that the force is applied horizontally (rope angle shall be  $0 \pm 0.5^\circ$ ). Remove the 8 lb weight after 1 minute. Measure the displacement.

(J) 7.7.5.3 If the walker is equipped with fixed direction rear wheels and the walker is displaced in a curved path, establish the location of the rope

attachment as the reference point and measure the linear displacement of that reference point after performing the procedure as described in 7.7.5.1 and 7.7.5.2.

(K) 7.7.6 *Rearward facing test of parking devices.*

(L) 7.7.6.1 Position the walker including the Test Mass facing rearward so that plane A is perpendicular to the front edge of the platform and passes through the center of the pulley. Engage all parking devices in accordance with the manufacturers' instructions.

(M) 7.7.6.2 Within one minute of placing the walker with the Test Mass on the platform, attach an 8 lb weight gradually within 5 seconds to the walker frame base at plane A by means of a rope and a pulley per the test apparatus specifications in the step test procedure, adjusted so that the force is applied horizontally (rope angle shall be  $0 \pm 0.5^\circ$ ). Remove the 8 lb weight after 1 minute. Measure the displacement.

(ii) [Reserved]

(21) In addition to complying with section 8.2.3.2 of ASTM F 977–07, comply with the following:

(i) 8.2.3.3 A warning statement shall address the following:

WARNING: Parking brake use does not totally prevent walker movement. Always keep child in view when in the walker, even when using the parking brakes.

(ii) [Reserved]

(22) Instead of complying with section 8.2.4.2 of ASTM F 977–07, comply with the following:

(i) 8.2.4.2 The stairs warning shall be stated exactly as follows:

**▲ WARNING – STAIR HAZARD**

Avoid serious injury or death

Block stairs/steps securely before using walker, even when using parking brake.

(ii) [Reserved]

Dated: June 9, 2010.

**Todd Stevenson,**

Secretary, U.S. Consumer Product Safety Commission.

[FR Doc. 2010-14323 Filed 6-18-10; 8:45 am]

BILLING CODE 6355-01-P

**CONSUMER PRODUCT SAFETY COMMISSION****16 CFR Part 1500****RIN 3041-AC77****Revocation of Regulations Banning Certain Baby-Walkers****AGENCY:** Consumer Product Safety Commission.**ACTION:** Final rule.

**SUMMARY:** In this document, the Consumer Product Safety Commission (“CPSC” or “Commission”) is revoking its existing regulations pertaining to baby-walkers because those regulations are being replaced by a new and more comprehensive safety standard applicable to baby-walkers. The new standard is being added by the Commission in a separate document published elsewhere in this issue of the **Federal Register**.

**DATES:** Effective December 21, 2010.

**FOR FURTHER INFORMATION CONTACT:** Carolyn Manley, Division of Regulatory Enforcement, Office of Compliance, Consumer Product Safety Commission, 4330 East West Highway, Bethesda, MD 20814, 301-504-7607, [cmanley@cpsc.gov](mailto:cmanley@cpsc.gov).

**SUPPLEMENTARY INFORMATION:****A. Background**

1. *The CPSC’s regulation for baby-walkers.* CPSC regulations at 16 CFR 1500.18(a)(6) and 1500.86(a)(4) ban any “baby-bouncer,” “walker-jumper,” “baby-walker,” and “any other similar article” that does not meet specified safety criteria. These regulations were issued in 1971 by the Food and Drug Administration (“FDA”) under the Federal Hazardous Substances Act (“FHSA”), 15 U.S.C. 1261-1278 (available at <http://www.cpsc.gov/businfo/fhsa.pdf>). 36 FR 21809 (Nov. 16, 1971). On May 14, 1973, the functions under the FHSA were transferred to the then newly-created CPSC.

Specifically, 16 CFR 1500.18(a)(6) bans baby-walkers, baby-bouncers, walker-jumpers and “any other similar article” that is intended to support very young children while “sitting walking, bouncing, jumping, and/or reclining,” and which, because of its design, has any exposed parts capable of causing amputation, crushing, lacerations, fractures, hematomas, bruises, or other injuries to fingers, toes, or other parts of the anatomy of young children. The regulation describes the hazardous design features of such articles warranting the ban as including, but not being limited to, one or more of the following:

- Areas about the point on each side of the article where the frame components are joined together to form an X-shape capable of producing a scissoring, shearing, or pinching effect;
- Other areas where two or more parts are joined in such a manner as to permit rotational movement capable of exerting a scissoring, shearing, or pinching effect;
- Exposed coil springs which may expand sufficiently to allow an infant’s finger, toe, or other body part to be inserted, in whole or in part, and injured by being caught between the coils of the spring or between the spring and another part of the article;
- Holes in plates or tubes which also provide the possibility of insertion of a finger, toe, or other part of the anatomy that could then be injured by the movement of another part of the article; or
- A design and construction that permits accidental collapse while in use.

Exemptions to the ban are at 16 CFR 1500.86(a)(4). These include any baby-walker (or the other subject products) where:

- The frames are designed and constructed in a manner to prevent injury from any scissoring, shearing, or pinching when the members of the frame or other components rotate about a common axis or fastening point or otherwise move relative to one another; and
- Any coil springs which expand when the article is subjected to a force that will extend the spring to its maximum distance so that a space between successive coils is greater than one-eighth inch (0.125 inch) are covered

or otherwise designed to prevent injuries; and

- All holes larger than one-eighth inch (0.125 inch) in diameter, and slots, cracks, or hinged components in any portion of the article through which a child could insert, in whole or in part, a finger, toe, or any other part of the anatomy, are guarded or otherwise designed to prevent injuries; and
- The articles are designed and constructed to prevent accidental collapse while in use; and
- The articles are designed and constructed in a manner that eliminates from any portion of the article the possibility of presenting a mechanical hazard through pinching, bruising, lacerating, crushing, breaking, amputating, or otherwise injuring portions of the human body when in normal use or when subjected to reasonably foreseeable damage or abuse; and

• Any article which is introduced into interstate commerce after the effective date of [the regulation] is labeled:

—With a conspicuous statement of the name and address of the manufacturer, packer, distributor, or seller; and

—With a code mark on the article itself and on the package containing the article or on the shipping container, in addition to the invoice(s) or shipping document(s), which code mark will permit future identification by the manufacturer of any given model (the manufacturer shall change the model number whenever the article undergoes a significant structural or design modification); and

- The manufacturer or importer of the article shall make, keep, and maintain for 3 years records of sale, distribution, and results of inspections and tests conducted in accordance with this subparagraph and shall make such records available at all reasonable hours upon request by any officer or employee of the Consumer Product Safety Commission and shall permit such officer or employee to inspect and copy such records, to make such stock inventories as such person deems necessary, and to otherwise check the correctness of such records.

The existing regulations do not include any requirements specifically