

DEPARTMENT OF TRANSPORTATION

National Highway Traffic Safety Administration

49 CFR Parts 571 and 585

[Docket No. NHTSA-2009-0093]

RIN 2127-AG51

Federal Motor Vehicle Safety Standards; Roof Crush Resistance; Phase-In Reporting Requirements

AGENCY: National Highway Traffic Safety Administration (NHTSA), Department of Transportation.

ACTION: Final rule.

SUMMARY: As part of a comprehensive plan for reducing the risk of rollover crashes and the risk of death and serious injury in those crashes, this final rule upgrades the agency's safety standard on roof crush resistance in several ways.

First, for the vehicles currently subject to the standard, i.e., passenger cars and multipurpose passenger vehicles, trucks and buses with a Gross Vehicle Weight Rating (GVWR) of 2,722 kilograms (6,000 pounds) or less, the rule doubles the amount of force the vehicle's roof structure must withstand in the specified test, from 1.5 times the vehicle's unloaded weight to 3.0 times the vehicle's unloaded weight. Second, the rule extends the applicability of the standard so that it will also apply to vehicles with a GVWR greater than 2,722 kilograms (6,000 pounds), but not greater than 4,536 kilograms (10,000 pounds). The rule establishes a force requirement of 1.5 times the vehicle's unloaded weight for these newly included vehicles. Third, the rule requires all of the above vehicles to meet the specified force requirements in a two-sided test, instead of a single-sided test, i.e., the same vehicle must meet the force requirements when tested first on one side and then on the other side of the vehicle. Fourth, the rule establishes a new requirement for maintenance of headroom, i.e., survival space, during testing in addition to the existing limit on the amount of roof crush. The rule also includes a number of special provisions, including ones related to leadtime, to address the needs of multi-stage manufacturers, alterers, and small volume manufacturers.

DATES: If you wish to petition for reconsideration of this rule, your petition must be received by June 26, 2009.

Effective date: The date on which this final rule amends the CFR is July 13, 2009. The incorporation by reference of a publication listed in the rule is

approved by the Director of the Federal Register as of July 13, 2009.

Compliance dates:

Passenger cars and multipurpose passenger vehicles, trucks and buses with a GVWR of 2,722 kilograms (6,000 pounds) or less. This final rule adopts a phase-in of the upgraded roof crush resistance requirements for these vehicles. The phase-in begins on September 1, 2012. By September 1, 2015, all of these vehicles must meet the upgraded requirements, with certain exceptions. Vehicles produced in more than one stage and altered vehicles need not meet the upgraded requirements until September 1, 2016.

Multipurpose passenger vehicles, trucks and buses with a GVWR greater than 2,722 kilograms (6,000 pounds) and less than or equal to 4,536 kilograms (10,000 pounds). All of these vehicles must meet the requirements beginning September 1, 2016, with certain exceptions. Vehicles produced in more than one stage and altered vehicles need not meet the requirements until September 1, 2017.

ADDRESSES: If you wish to petition for reconsideration of this rule, you should refer in your petition to the docket number of this document and submit your petition to: Administrator, National Highway Traffic Safety Administration, 1200 New Jersey Avenue, SE., West Building, Washington, DC 20590.

The petition will be placed in the docket. Anyone is able to search the electronic form of all documents received into any of our dockets by the name of the individual submitting the document (or signing the document, if submitted on behalf of an association, business, labor union, etc.). You may review DOT's complete Privacy Act Statement in the **Federal Register** published on April 11, 2000 (Volume 65, Number 70; Pages 19477-78) or you may visit <http://www.dot.gov/privacy.html>.

FOR FURTHER INFORMATION CONTACT: For non-legal issues, you may call Christopher J. Wiacek, NHTSA Office of Crashworthiness Standards, telephone 202-366-4801. For legal issues, you may call J. Edward Glancy, NHTSA Office of Chief Counsel, telephone 202-366-2992. You may send mail to these officials at the National Highway Traffic Safety Administration, 1200 New Jersey Avenue, SE., West Building, Washington, DC 20590.

SUPPLEMENTARY INFORMATION:**Table of Contents**

- I. Executive Summary
 - a. Final Rule

- b. How This Final Rule Differs From the NPRM and/or SNPRM
- II. Overall Rollover Problem and the Agency's Comprehensive Response
 - a. Prevention
 - b. Occupant Containment
 - c. Occupant Protection
- III. The Role of Roof Intrusion in the Rollover Problem
- IV. The Agency's Proposed Rule
 - a. NPRM
 - b. SNPRM
 - c. Congressional Mandate
- V. Overview of Comments
- VI. Agency Decision and Response to Comments
 - a. Primary Decisions
 - 1. Basic Nature of the Test Requirements—Quasi-Static vs. Dynamic Tests
 - 2. Vehicle Application
 - 3. Single-Sided or Two-Sided Tests
 - 4. Upgraded Force Requirement—Specified Strength to Weight Ratio (SWR)
 - 5. Performance Criteria—Headroom, Platen Travel, or Both
 - 6. Leadtime and Phase-In
 - b. Aspects of the Test Procedure
 - 1. Tie-Down Procedure
 - 2. Platen Angle and Size
 - 3. Testing Without Windshields and/or Other Glazing in Place
 - 4. Deletion of Secondary Plate Positioning Procedure
 - 5. Removal of Roof Components
 - 6. Tolerances
 - c. Requirements for Multi-Stage and Altered Vehicles
 - d. Other Issues
 - 1. Convertibles and Open Bodied Vehicles
 - 2. Vehicles Without B-Pillars
 - 3. Heavier Vehicles With a High Height to Width Aspect Ratio
 - 4. Active Roofs
 - 5. Whether an Additional SNPRM Is Needed
 - 6. Rear Seat Occupants
 - 7. New Car Assessment Program (NCAP)
 - 8. Possible Energy Requirement
 - 9. Advanced Restraints
- VII. Costs and Benefits
- VIII. Rulemaking Analyses and Notices
 - Appendix A—Analysis of Comments Concerning Dynamic Testing
 - Appendix B—Two-Sided Test Results
 - Appendix C—Single-Sided Test Results

I. Executive Summary*a. Final Rule*

As part of a comprehensive plan for reducing the serious risk of rollover crashes and the risk of death and serious injury in those crashes, this final rule upgrades Federal Motor Vehicle Safety Standard (FMVSS) No. 216, *Roof Crush Resistance*.

For the vehicles currently subject to the standard, passenger cars and multipurpose passenger vehicles, trucks and buses with a GVWR of 2,722 kilograms (6,000 pounds) or less, the rule doubles the amount of force the vehicle's roof structure must withstand in the specified test, from 1.5 times the

vehicle's unloaded weight to 3.0 times the vehicle's unloaded weight. The rule also extends the applicability of the standard so that it will also apply to vehicles with a GVWR greater than 2,722 kilograms (6,000 pounds), but not greater than 4,536 kilograms (10,000 pounds), establishing a force requirement of 1.5 times the vehicle's unloaded weight for these heavier vehicles.

Under today's rule, all of the above vehicles must meet the specified force requirements in a two-sided test instead of a single-sided test, i.e., the same vehicle must meet the force requirements when tested first on one side and then on the other side of the vehicle. The rule also establishes a new requirement for maintenance of headroom, i.e., survival space, during testing, in addition to the existing limit on the amount of roof crush. The rule also includes special provisions to address the needs of multi-stage manufacturers, alterers, and small volume manufacturers.

NHTSA developed its proposal to upgrade roof crush resistance requirements after considerable analysis and research, including considering comments received in response to a Request for Comments (RFC) notice published in 2001. Prior to publishing the RFC, the agency conducted a research program to examine potential methods for improving the roof crush resistance requirements. The agency testing program included full vehicle dynamic rollover testing, inverted vehicle drop testing, and comparing inverted vehicle drop testing to a modified FMVSS No. 216 test. After considering the results of the testing and other available information, the agency concluded that the quasi-static procedure provides a suitable representation of the real-world dynamic loading conditions, and the most appropriate one on which to focus our upgrade efforts.

Today's rule reflects careful consideration of comments we received in response to the notice of proposed rulemaking (NPRM) published in 2005 and a supplemental notice of proposed rulemaking (SNPRM) published in January 2008. NHTSA published the SNPRM to obtain public comment on a number of issues that might affect the content of the final rule, including possible variations in the proposed requirements. In the SNPRM, the agency also announced the release of the results of various vehicle tests conducted since the NPRM.

While this rulemaking action to improve roof strength is part of our comprehensive plan for addressing the

serious problem of rollover crashes, this action, by itself, addresses a relatively small subset of that problem. There are more than 10,000 fatalities in rollover crashes each year. To address that problem, our comprehensive plan includes actions to (1) reduce the occurrence of rollovers, (2) mitigate ejection, and (3) enhance occupant protection when rollovers occur (improved roof crush resistance is included in this third category).

Our analysis shows that of the more than 10,000 fatalities that occur in rollover crashes each year, roof strength is relevant to only about seven percent (about 667) of those fatalities. We estimate that today's rule will prevent 135 of those 667 fatalities.

The portions of our comprehensive plan that will have the highest life-saving benefits are the ones to reduce the occurrence of rollovers (*prevention*) and to mitigate ejection (*occupant containment*). We estimate that by preventing rollovers, electronic stability control (ESC) will reduce the more than 10,000 fatalities that occur in rollover crashes each year by 4,200 to 5,500 fatalities (and also provide significant additional life-saving benefits by preventing other types of crashes). In the area of mitigating ejection, significant life-benefits are and/or will occur by our continuing efforts to increase seat belt use and our upcoming rulemaking on ejection mitigation. A more complete discussion of our comprehensive plan is discussed later in this document.

b. How This Final Rule Differs From the NPRM and/or SNPRM

The more noteworthy changes from the NPRM are outlined below and explained in detail later in this preamble. More minor changes are discussed in the appropriate sections of this preamble.

Higher force requirement (strength-to-weight ratio (SWR level)). While we proposed an SWR level of 2.5 in the NPRM for the vehicles that have been subject to the standard, we noted in the SNPRM that the agency could adopt a higher or lower value for this final rule. We are adopting an SWR of 3.0 for them in this final rule. An SWR of 1.5 will apply to the heavier light vehicles that have previously not been subject to the standard.

Two-sided test. While we proposed a single-sided test in the NPRM, we conducted additional testing and addressed the possibility of a two-sided test in the SNPRM. Today's rule adopts a two-sided test requirement for all vehicles subject to the standard.

Maintaining intrusion limit in addition to new headroom requirement. In the NPRM, we proposed to replace the current limit on intrusion (platen travel requirement) with a new headroom requirement. For this final rule, we are maintaining the intrusion limit as well as adopting the proposed headroom requirement.

Use of headform positioning fixture instead of a test dummy. In the NPRM, we proposed to use test dummies as part of the test procedure for measuring headroom. For this final rule, we are using headform positioning fixtures for this purpose.

Phase-in. We did not include a phase-in in the NPRM. For this final rule, we are phasing in the upgraded roof strength requirements for the lighter vehicles previously subject to FMVSS No. 216, and providing longer leadtime (without a phase-in) for the heavier light vehicles.

Limited exclusion for certain multi-stage trucks. Due to concerns about practicability, we are excluding from FMVSS No. 216 a very limited group of multistage trucks with a GVWR greater than 2,722 kilograms (6,000 pounds), ones not built on either a chassis cab or an incomplete vehicle with a full exterior van body.

Updated benefits and costs. We have updated our analysis of benefits and costs. Our analysis appears in summary form in this document, and in its entirety in the agency's Final Regulatory Impact Analysis (FRIA).

We estimate that the changes in FMVSS No. 216 will prevent 135 fatalities and 1,065 nonfatal injuries annually. The agency estimates that compliance with the upgraded roof strength standard will increase lifetime consumer costs by \$69–114 per affected vehicle. Redesign costs are expected to increase affected vehicle prices by an average of about \$54. Added weight is estimated to increase the lifetime cost of fuel usage by \$15 to \$62 for an average affected vehicle. Total consumer costs are expected to range from \$875 million to \$1.4 billion annually.

Implied Preemption. We have reconsidered the tentative position presented in the NPRM. We do not foresee any potential State tort requirements that might conflict with today's final rule. Without any conflict, there could not be any implied preemption.

II. Overall Rollover Problem and the Agency's Comprehensive Response

Addressing vehicle rollovers is one of NHTSA's highest safety priorities. According to 2007 FARS crash data, 10,196 people were killed as occupants

in light vehicle rollover crashes, which represents 35 percent of all occupants killed that year in crashes. FARS reported that approximately 57 percent were partially or completely ejected from the vehicle (including approximately 47 percent who were completely ejected).

Rollover crashes are complex and chaotic events. Rollovers can range from a single quarter turn to eight or more quarter turns, with the duration of the rollover crash lasting from one to several seconds. The wide range of rollover conditions occurs because these crashes largely occur off road where the vehicle motion is highly influenced by roadside conditions. Also, rollover crashes tend to occur at higher speeds than other crash types due to the energy required to initiate the rollover motion.

NHTSA has been pursuing a comprehensive and systematic approach towards reducing the fatalities and serious injuries that result from rollover crashes. As part of our safety standard rulemaking, this approach establishes various repeatable test procedures and performance requirements that will generate countermeasures effective in the chaotic real-world events. Due to the complex nature of a rollover event and the particularized effect of each element of the comprehensive approach taken by the agency to address these crashes, each element addresses a specific segment of the total rollover problem. Accordingly, each initiative has a different target population and interacts with each of the other rollover strategies. NHTSA has initiatives in place to:

1. Reduce the occurrence of rollover crashes (e.g., the requirement for ESC on all light vehicles and the NCAP rollover ratings),

2. Keep occupants inside the vehicle when rollovers occur (e.g., NHTSA's unyielding commitment to get passengers to buckle their seat belts every time they ride in a vehicle, as well as the requirement for enhanced door latches and the forthcoming rulemaking for ejection mitigation), and

3. Better protect the occupants kept inside the vehicle during the rollover (e.g., the requirement for upper interior head protection and this rulemaking for enhanced roof crush resistance).

Each of these three initiatives must work together to address the various aspects of the rollover problem.

a. Prevention

The most effective way to reduce deaths and injuries in rollover crashes is to prevent the rollover crash from occurring. On April 6, 2007, NHTSA published a final rule establishing

FMVSS No. 126, "Electronic stability control systems," to require ESC on passenger cars, multipurpose passenger vehicles, trucks, and buses with a GVWR of 4,536 kilograms (10,000 pounds) or less. ESC systems use automatic computer-controlled braking of individual wheels to assist the driver in maintaining control in critical driving situations in which the vehicle is beginning to lose directional stability at the rear wheels or directional control at the front wheels. ESC systems effectively monitor driver steering input and limit vehicle oversteer and understeer, as appropriate. To comply with the new ESC standard, vehicles will need individually adjustable braking at all four wheels, and computer electronics to utilize this capability, a means for engine torque adjustability and various onboard sensors (to measure yaw rate, lateral acceleration, steering wheel angle and speed). The agency estimates that ESC will save 5,300 to 9,600 lives in all types of crashes annually once all light vehicles on the road are equipped with ESC. The agency further anticipates that ESC systems will substantially reduce (by 4,200 to 5,500 deaths) the more than 10,000 deaths each year resulting from rollover crashes.

b. Occupant Containment

Studies have shown that the fatality rate for an ejected vehicle occupant is three times as great as that for an occupant who remains inside of the vehicle. Thus, mitigating ejections offers potential for significant safety gains. Safety belts are the most effective crashworthiness countermeasure in reducing ejected rollover fatalities. Studies have found that safety belts reduce fatalities in rollovers by 74 percent in passenger cars and 80 percent for light trucks.¹ NHTSA requires all vehicles manufactured after 1968 to have safety belts as standard equipment.

However, of the 6,164 ejected occupant fatalities in light vehicle rollover crashes, as reported by 2006 FARS, 1,135 were classified as partial ejections. Fatal injuries from partial ejection can occur even to belted occupants, e.g., when their head protrudes outside the window and strikes the ground in a rollover. Therefore, as mandated by SAFETEA-LU, NHTSA is working to establish performance standards to reduce partial and complete ejection from outboard seating position windows.

¹ Kahane, C. J., Fatality Reduction by Safety Belts for Front-Seat Occupants of Cars and Light Trucks: Updated and Expanded Estimates Based on 1986–99 FARS Data (NHTSA Report No. DOT HS 809 199).

Doors represent another common ejection route. As part of the agency's comprehensive approach to rollover, and to harmonize with the first Global Technical Regulation, NHTSA upgraded FMVSS No. 206, "Door locks and door retention components," in a final rule published on February 6, 2007. This final rule added test requirements for sliding doors, upgraded the door retention requirements, added secondary latch requirements for doors other than hinged side doors and back doors, and provided a new test procedure for assessing inertial forces. To comply with the new requirements, it is anticipated that passenger vehicles with sliding doors designed with one latch and pin locking mechanism will need to be redesigned with two latches. The technology needed to meet the upgraded standard would benefit vehicles in rollover crashes where door openings were identified as a problem.

c. Occupant Protection

Finally, when a rollover crash does occur and the occupants have been contained within the vehicle compartment, it is important for the roof structure to remain intact and maintain survival space. That is the safety need addressed by today's final rule.

III. The Role of Roof Intrusion in the Rollover Problem

Due to the high effectiveness of ESC in preventing an increasing number of rollover crashes, and seat belts at preventing ejection, the remaining target population relevant to roof crush occupant protection is a relatively small subset of the occupants injured in rollovers. For fatalities, the estimated total for the target population² is about seven percent (about 667) of all non-convertible light vehicle rollover fatalities. Although the target population and potential for lives saved are substantially smaller than can be attained by the first two strategies of our comprehensive rollover plan, it is nevertheless a very important aspect of the plan.

Looking at the target population relevant to roof crush occupant protection more specifically, Table 1 below shows a breakdown of the target population that could potentially benefit from roof crush improvements. The target population for all light vehicles is stratified by injury severity. The injury mechanism due to roof crush for belted occupants is that the roof crushes during the roll event, intrudes

² The target population estimates were based upon the results from the 1997–2006 National Automotive Sampling System-Crashworthiness Data System (NASS-CDS).

into the occupant compartment, and causes head, face, or neck injury. The table demonstrates how the final target population is derived from the broad category of rollovers by eliminating cases in which roof strength improvements would not be effective in

reducing serious and fatal injuries. For example, a stronger roof would not be expected to provide benefits in cases where the roof was not involved; where the occupant was totally ejected from the vehicle,³ or where the most serious

injury was not to the head, neck, or face due to the intruding roof.

The final target populations are shown in bold at the bottom of the table. A full discussion of the basis for the target population is included in the FRIA.

TABLE 1—TARGET POPULATION POTENTIALLY AFFECTED BY IMPROVED ROOF STRENGTH⁴

	AIS 1	AIS 2	AIS 3–5	Fatalities
All Light Vehicles				
All Vehicles:				
Non-Convertible Light Vehicles in Rollovers	199,822	37,305	21,673	10,150
Roof-Involved Rollover	164,213	32,959	19,262	8,645
Some Fixed Object Collision on Top	153,520	29,419	17,766	7,559
Not Totally Ejected	149,850	26,033	12,355	3,654
Using Safety Restraints	116,670	14,327	8,970	2,096
Outboard Seats	115,018	14,241	8,781	2,096
Roof Component Intrusion	68,730	10,922	6,842	1,444
Head, Neck, or Face Injury From Intruding Roof Component	24,035	6,580	2,993	957
Injury—Not MAIS ⁵	0	–1,900	–1,252	–237
Injury at MAIS—Not Sole Injury	–17,818	–292	–253	–53
Sole MAIS Injury	6,216	4,388	1,487	667
Light Vehicles With a GVWR of 2,722 Kilograms (6,000 Pounds) or Less				
PC & LT < 6,000 lbs:				
Non-Convertible Light Vehicles in Rollovers	172,846	33,170	18,929	8,719
Roof-Involved Rollover	144,410	29,098	17,360	7,536
Some Fixed Object Collision on Top	136,080	26,270	16,122	6,484
Not Totally Ejected	133,241	23,400	11,406	3,142
Using Safety Restraints	104,571	12,421	8,379	1,936
Outboard Seats	103,249	12,373	8,190	1,936
Roof Component Intrusion	60,061	9,370	6,372	1,304
Head, Neck, or Face Injury From Intruding Roof Component	20,687	5,868	2,615	842
Injury—Not MAIS	0	–1,771	–1,119	–157
Injury at MAIS—Not Sole Injury	–16,082	–262	–212	–50
Sole MAIS Injury	4,605	3,835	1,283	635
Light Vehicles With a GVWR above 2,722 Kilograms (6,000 Pounds)				
LT > 6,000 lbs:				
Non-Convertible Light Vehicles in Rollovers	26,975	4,135	2,744	1,431
Roof-Involved Rollover	19,803	3,861	1,902	1,110
Some Fixed Object Collision on Top	17,440	3,149	1,644	1,075
Not Totally Ejected	16,608	2,634	949	511
Using Safety Restraints	12,099	1,906	591	160
Outboard Seats	11,770	1,868	591	160
Roof Component Intrusion	8,669	1,552	471	140
Head, Neck, or Face Injury From Intruding Roof Component	3,348	712	378	116
Injury—Not MAIS	0	–128	–133	–80
Injury at MAIS—Not Sole Injury	–1,736	–31	–40	–3
Sole MAIS Injury	1,611	553	205	33

The most significant exclusions resulted from requirements that fatalities occurred in rollovers in which (1) the roof was damaged in a rollover,

(2) the damage was not caused by collision with a fixed object, (3) the fatally injured occupants were not

ejected, and (4) those occupants were belted.

It is important to understand what Table 1 indicates about the safety

³ Strashny, “The Role of Vertical Roof Intrusion in Predicting Occupant Ejection,” 2009. Strashny found that there was no statistically significant relationship between the level of roof intrusion and the probability of complete ejection. For this reason

completely ejection occupants were excluded from the target population. However, partial ejections that meet the established criteria are included.

⁴ Note: The relevant target population used for the estimation of benefits is identified in the row titled

“Sole MAIS Injury.” Also, the numbers reflect rounding errors.

⁵ Injury—Not MAIS: This means that the most serious injury was to a portion of the body other than the head, neck or face.

potential of addressing roof crush. Even if there were some way to prevent every single rollover death resulting from roof crush, the total lives saved would be 667, not the approximately 10,000 deaths that result from rollover each year. This is why each initiative in NHTSA's comprehensive program to address the different aspects of the rollover problem is so important.

The details of today's rule upgrading roof crush occupant protection, including costs and benefits and the agency's analysis of the public comments on our NPRM and SNPRM, are discussed in the rest of this document.

IV. The Agency's Proposed Rule

a. NPRM

On August 23, 2005, NHTSA published in the **Federal Register** (70 FR 49223) a NPRM to upgrade FMVSS No. 216, *Roof Crush Resistance*.⁶ FMVSS No. 216 seeks to reduce deaths and serious injuries resulting from the roof being crushed and pushed into the occupant compartment when the roof strikes the ground during rollover crashes.

Current requirements.

FMVSS No. 216 currently applies to passenger cars, and to multipurpose passenger vehicles, trucks and buses with a GVWR of 2,722 kilograms (6,000 pounds) or less.

The standard requires that when a large steel test plate (sometimes referred to as a platen) is placed in contact with the roof of a vehicle and then pressed downward, simulating contact of the roof with the ground during a rollover crash, with steadily increasing force until a force equivalent to 1.5 times the unloaded weight of the vehicle is reached, the distance that the test plate has moved from the point of contact must not exceed 127 mm (5 inches). The criterion of the test plate not being permitted to move more than a specified amount is sometimes referred to as the "platen travel" criterion. Under S5 of the standard, the application of force is limited to 22,240 Newtons (5,000 pounds) for passenger cars, even if the unloaded weight of the car times 1.5 is greater than that amount.

Proposed upgrade.

As discussed in the August 2005 NPRM, we developed our proposal to upgrade roof crush resistance requirements after considerable analysis and research, including considering comments received in response to a RFC published in the **Federal Register** (66 FR 53376)⁷ on October 22, 2001. Prior

to publishing the RFC, the agency conducted a research program to examine potential methods for improving the roof crush resistance requirements. The agency testing program included full vehicle dynamic rollover testing, inverted vehicle drop testing, and comparing inverted drop testing to a modified FMVSS No. 216 test. After considering the results of the testing and other available information, the agency concluded that the quasi-static procedure provides a suitable representation of the real-world dynamic loading conditions, and the most appropriate one on which to focus our upgrade efforts.

In our August 2005 NPRM, to better address fatalities and injuries occurring in roof-involved rollover crashes, we proposed to extend the application of the standard to vehicles with a GVWR of up to 4,536 kilograms (10,000 pounds), and to strengthen the requirements of FMVSS No. 216 by mandating that the vehicle roof structures withstand a force equivalent to 2.5 times the unloaded vehicle weight, and to eliminate the 22,240 Newton (5,000 pound) force limit for passenger cars.

Further, in recognition of the fact that the pre-test distance between the interior surface of the roof and a given occupant's head varies from vehicle model to vehicle model, we proposed to regulate roof strength by requiring that the crush not exceed the available headroom. Under the proposal, this requirement would replace the current limit on test plate movement.

The proposed new limit would prohibit any roof component from contacting the head of a seated 50th percentile male dummy when the roof is subjected to a force equivalent to 2.5 times the unloaded vehicle weight. We note that this value is sometimes referred to as the strength-to-weight ratio (SWR), e.g., a SWR of 1.5, 2.5, and so forth.

We also proposed to:

- Allow vehicles manufactured in two or more stages, other than chassis-cabs, to be certified to the roof crush requirements of FMVSS No. 220, *School bus rollover protection*, instead of FMVSS No. 216.
- Clarify the definition and scope of exclusion for convertibles.
- Revise the vehicle tie-down procedure to minimize variability in testing.

To accompany our proposal, we prepared a Preliminary Regulatory Impact Analysis (PRIA) describing the costs and benefits. We estimated that, if adopted, the proposal would result in 13–44 fewer fatalities and 498–793

fewer non-fatal injuries each year. The total estimated recurring fleet cost was \$88 to \$95 million. We estimated that approximately 32 percent of the current vehicle fleet would need improvements to meet the proposed upgraded requirements.

b. SNPRM

On January 30, 2008, NHTSA published in the **Federal Register** (73 FR 5484) an SNPRM for our ongoing roof crush resistance rulemaking.⁸ In that document, we asked for public comment on a number of issues that might affect the content of the final rule, including possible variations in the proposed requirements. We also announced the release of the results of various vehicle tests conducted since the proposal.

In the SNPRM, we noted that we had been carefully analyzing the numerous comments we had received on the NPRM, as well as the various additional vehicle tests, including both single-sided tests and two-sided tests, conducted since the NPRM. We invited comments on how the agency should factor the new information into its decision. We noted that while the NPRM focused on a specified force equivalent to 2.5 times the unloaded vehicle weight, the agency could adopt a higher or lower value for the final rule. We explained, with respect to two-sided testing, that we believed there was now sufficient available information for the agency to consider a two-sided requirement as an alternative to the single-sided procedure described in the NPRM. We stated that we planned to evaluate both the single-sided and two-sided testing alternatives for the final rule and requested comments that would help us reach a decision on that issue.

We also noted in the SNPRM that the agency had conducted additional analysis concerning the role of vertical roof intrusion and post-crash headroom in predicting roof contact injuries to the head, neck or face during FMVSS No. 216 rollovers. At the time of the NPRM, the agency estimated benefits based on post-crash headroom, the only basis for which a statistical relationship with injury reduction had been established. After the NPRM, with additional years of data available, a statistically significant relationship between intrusion and injury for belted occupants was established.

c. Congressional Mandate

Section 10301 of SAFETEA-LU generally required the Secretary to issue

⁶ Docket No. NHTSA–2005–22143.

⁷ Docket No. NHTSA–1999–5572.

⁸ Docket No. NHTSA–2008–0015.

a final rule upgrading roof crush resistance by July 1, 2008, while providing for a later date under certain circumstances. That section provides:

Sec. 10301. VEHICLE ROLLOVER PREVENTION AND CRASH MITIGATION.

(a) In General.—Subchapter II of chapter 301 is amended by adding at the end the following:

§ 30128. Vehicle rollover prevention and crash mitigation

(a) IN GENERAL.—The Secretary shall initiate rulemaking proceedings, for the purpose of establishing rules or standards that will reduce vehicle rollover crashes and mitigate deaths and injuries associated with such crashes for motor vehicles with a gross vehicle weight rating of not more than 10,000 pounds.

* * * * *

(d) Protection of Occupants.—One of the rulemaking proceedings initiated under subsection (a) shall be to establish performance criteria to upgrade Federal Motor Vehicle Safety Standard No. 216 relating to roof strength for driver and passenger sides. The Secretary may consider industry and independent dynamic tests that realistically duplicate the actual forces transmitted during a rollover crash. The Secretary shall issue a proposed rule by December 31, 2005, and a final rule by July 1, 2008.

The statute provides that if the Secretary determines that the July 1, 2008 deadline for the final rule cannot be met, the Secretary is to notify Congress and explain why that deadline cannot be met, and establish a new date. The Secretary provided such notifications to Congress, and established a date of April 30, 2009.

V. Overview of Comments

NHTSA received comments from a wide variety of interested parties, including vehicle manufacturers and their trade associations, suppliers of automobile equipment and a supplier trade association, consumer advocacy and other organizations, trial lawyers, engineering firms and consultants, members of academia, elected officials and government organizations, and private individuals. All of the comments may be found in the docket for the NPRM or SNPRM. In this section, we provide a broad overview of the significant comments. Where we identify specific commenters, we cite representative comments.

General Approach and SWR

Vehicle manufacturers were generally supportive of the agency's proposal, while recommending a number of specific modifications. They generally supported a SWR of 2.5, with caveats about sufficient leadtime and test procedure issues. They expressed

concerns about SWRs higher than 2.5, including potential adverse effects on safety resulting from increased mass.

Consumer advocacy organizations and a number of other commenters argued that it is not enough to upgrade the current quasi-static requirement, and that a dynamic test requirement is needed. While specific recommendations varied, one was for the agency to adopt an upgraded quasi-static requirement now, and to proceed with further rulemaking for a dynamic test.

Advocates for Highway Safety (Advocates) stated that the proposed quasi-static test cannot demonstrate actual roof crush resistance in rollover crashes and that a dynamic test would address occupant kinematics and injury responses in actual rollover crashes. Public Citizen stated that a dynamic test could simultaneously evaluate the performance of seat belts, doors, ejection and the roof. A number of commenters supported specific dynamic tests.

The Center for Auto Safety (CAS) stated that while it strongly supports a dynamic test, it believes rollover protection can be dramatically improved with a well-crafted quasi-static test. It argued that test procedure changes related to roll angle and pitch angle are needed to ensure that the roof receives appropriate shear stress.

As to the SWR for an upgraded quasi-static test requirement, consumer advocacy organizations and a number of other commenters argued that the SWR should be significantly higher than 2.5. Many of these commenters recommended a SWR of 3.5, with some recommending higher levels.

The Insurance Institute for Highway Safety (IIHS) submitted a new study which it said supports increasing the SWR beyond 2.5. It stated that based on the current evidence, it supports a SWR of 3.0 to 3.5.

Performance Criterion

The agency received a variety of comments on the proposed headroom reduction criterion. Some commenters, including consumer groups, supported a headroom reduction criterion but argued that a platen travel criterion is also needed. Several commenters expressed concern that, for some vehicles, the proposed headroom reduction criterion would be less stringent and less protective than the current platen travel criterion. The agency also received comments recommending that the agency make these criteria more stringent to protect taller occupants, e.g., by using a 95th percentile adult male dummy instead of

a 50th percentile adult male dummy to measure headroom and by reducing the amount of platen travel that is permitted.

Vehicle manufacturers urged the agency to retain the current platen travel criterion instead of adopting a headroom reduction criterion. They argued, among other things, that using the headroom reduction criterion would add unnecessary complexity to the test procedure and result in problems related to repeatability and practicability. Some manufacturers stated that if the agency adopts a headroom reduction criterion, it should adopt a test procedure using a head positioning fixture instead of a test dummy.

IIHS stated that relating the allowable amount of roof crush in the quasi-static test to the headroom in specific vehicles is a good concept but that, in practice, the agency's research tests have not shown that replacing the 5-inch platen travel criterion with the headroom requirement would be a meaningful change to the standard and may not justify the added complications to the test procedure.

Single- or Two-Sided Testing

Several consumer advocacy organizations and other commenters strongly supported two-sided testing. Public Citizen stated that in a vast majority of rollover cases, the injured party was typically seated on the far side, that is, the side of the second impact. It argued that it is not possible to upgrade FMVSS No. 216 without a two-sided test requirement.

IIHS stated that while it supports any changes that would increase the level of roof strength of the vehicle fleet, it has no real-world data to address the potential benefits of two-sided testing. It stated that a single-sided test with a higher SWR may be more effective at promoting robust roof designs than a two-sided test with a lower SWR requirement.

The comments of vehicle manufacturers were somewhat mixed on the issue of single- or two-sided testing. The Alliance of Automobile Manufacturers (Alliance) stated that it believes the agency has provided insufficient justification for two-sided testing. It stated that the agency has not provided analysis demonstrating that two-sided testing relates to real-world safety. The Alliance also expressed concern that two-sided testing would amplify variability and repeatability problems.

The Association of International Automobile Manufacturers (AIAM) stated that based on the information and

analysis provided by the agency regarding the two-sided test, it believes that the test shows enough potential to merit further consideration by the agency. AIAM argued that additional analysis would be needed before it could provide a preferred regulatory approach, but indicated that the two-sided approach would more directly address the multiple roof contact weakening phenomenon.

Leadtime

Vehicle manufacturers argued that a phase-in is needed for the upgraded roof crush requirements. The Alliance stated that if the final rule reflected a reasonable accommodation of the issues raised in its comments, it would be reasonable for a phase-in to begin, with a compliance percentage of 20 percent, on the first September 1, that occurred more than 36 months after issuance of the final rule. That organization stated that it would not be practicable to apply the upgraded requirements to all new vehicles at once, since far more vehicle models require redesigns than anticipated by NHTSA. The Alliance requested a phase-in that incorporates carryforward credits. It stated that additional leadtime would be necessary if the agency adopted a head contact criterion instead of platen travel, a two-sided test or a SWR higher than 2.5.

Costs and Benefits

Many commenters addressed the PRIA, which analyzed the costs and benefits and other impacts of the proposed rule, and a later discussion of these impacts included in the SNPRM. Among other things, commenters addressed the target population, the pass/fail rate of the current fleet, cost and weight impacts, and estimates of benefits.

Preemption

We received numerous comments on our discussion in the NPRM of the possible preemptive effect of an upgraded roof crush standard on State common law tort claims. Vehicle manufacturers and one organization strongly supported the view that an upgraded roof crush standard would conflict with and therefore impliedly preempt State rules of tort law imposing more stringent requirements than the one ultimately adopted by NHTSA. Consumer advocacy groups, members of Congress and State officials, trial lawyers, consultants, members of academia, and private individuals strongly opposed that view. The opposing comments from State officials included one signed by 27 State

Attorneys General and the National Conference of State Legislatures.

Other Issues

We received comments on many other issues. Commenters addressed a number of issues concerning the FMVSS No. 216 test procedure, including the vehicle tie-down procedure, platen angle and size, and whether the vehicle should be tested with the windshield and/or other glazing in place. Commenters also addressed requirements for multi-stage vehicles.

June 2008 Congressional Hearing and Letters

On June 4, 2008, the Subcommittee on Consumer Affairs, Insurance, and Automotive Safety of the Senate Commerce, Science and Transportation Committee held an oversight hearing on passenger vehicle roof strength. Former NHTSA Deputy Administrator James Ports testified at the hearing. At the hearing and also in a subsequent letter to Secretary Peters dated June 19, 2008, several Senators encouraged the agency to extend the July 1, 2008 date for completing a final rule. They encouraged the agency to ensure a rulemaking that would maximize vehicle safety and significantly reduce deaths and injuries for drivers and passengers in vehicle rollover crashes.

Several Senators encouraged NHTSA to consider a two-sided test requirement and a higher SWR requirement than the proposed 2.5 level, and to provide detailed information concerning alternatives considered by the agency. They also raised concerns about the use of 50th percentile adult male test dummies instead of ones representing taller occupants. The Senators also expressed significant concerns about possible preemption of common law tort actions, and asked that such a provision not be included in the final rule.

In a letter to Secretary Peters dated June 27, 2008, Chairman Henry Waxman of the House Committee on Oversight and Government Reform, raised similar concerns to those of the Senators.

New IIHS Roof Strength Consumer Information Program

On February 19, 2009, IIHS met with NHTSA representatives to provide the agency information about a new roof strength consumer information program that the organization is initiating. IIHS believes the FMVSS No. 216 test procedure is a meaningful structural assessment of real-world rollover crashworthiness as shown by recent studies it has conducted showing that improved roof strength reduces injury

risk in midsize SUVs and small cars. That organization indicated that the boundary for a good rating in the IIHS program will be a SWR of 4.0 in a one-sided platen test similar to the existing FMVSS No 216 test procedure. IIHS indicated that it does not plan to rate the larger, heavier light vehicles, i.e., ones likely to have GVWRs greater than 2,722 kilograms (6,000 pounds).

On March 24, 2009, IIHS issued a press release announcing a number of details about its new rating system, including ratings for 12 small SUVs. For an acceptable rating, the minimum SWR is 3.25. A marginal rating value is 2.5. Anything lower than that is rated as poor. In order to earn IIHS's "top safety pick" award for 2010, vehicles will need to have a good roof strength rating, i.e., SWR of 4.0. Of the 12 small SUVs tested by IIHS, eight were rated by that organization as good, five as acceptable, two as marginal, and one as poor.

VI. Agency Decision and Response to Comments

a. Primary Decisions

1. Basic Nature of the Test Requirements—Quasi-Static vs. Dynamic Tests

As noted above and discussed in detail in the NPRM, we developed our proposal to upgrade roof crush resistance requirements after considerable analysis and research, including conducting a research program to examine potential methods for improving the roof crush resistance requirements. The agency testing program included full vehicle dynamic rollover testing, inverted vehicle drop testing, and comparing inverted drop testing to a modified FMVSS No. 216 test. After considering the results of the testing and other available information, the agency concluded that the quasi-static procedure provides a suitable representation of the real-world dynamic loading conditions, and the most appropriate one on which to focus our upgrade efforts.

We did not propose a dynamic test procedure in either the NPRM or the SNPRM. We did discuss in the NPRM a number of types of dynamic tests and why we were not including them in the proposal. We stated our belief that the current quasi-static test procedure is repeatable and capable of simulating real-world deformation patterns. We also stated that we were unaware of any dynamic test procedure that provides a sufficiently repeatable test environment.

Consumer advocacy organizations and a number of other commenters argued that it is not enough to upgrade the current quasi-static requirement, and

that a dynamic test requirement is needed. While specific recommendations varied, one was for the agency to adopt an upgraded quasi-static requirement now, and to proceed with further rulemaking at this time for a dynamic test.

Advocates stated that the proposed quasi-static test cannot demonstrate actual roof crush resistance in rollover crashes and that a dynamic test would address occupant kinematics and injury responses in actual rollover crashes. Public Citizen stated that a dynamic test could simultaneously evaluate the performance of seat belts, doors, ejection mitigation and the roof. A number of commenters made specific recommendations concerning the type of dynamic test that the agency should propose, e.g., with a number recommending the FMVSS No. 208 dolly test and/or the Jordan Rollover System (JRS) test.

As part of our considering the merits of a dynamic test and comments on the JRS, on February 23, 2007, NHTSA representatives met with Xprts, LLC (Xprts) at its test facility in Goleta, CA, to view and discuss the device. CAS and Center for Injury Research (CFIR) also submitted additional test data to the agency using the JRS.

We note that the agency is also aware of tests used by manufacturers to assess a vehicle's rollover performance during vehicle development and conditions they are designed to represent such as the curb trip, soil trip, the bounce over, etc.⁹

As noted earlier in this document, rollover crashes are complex and chaotic events. Rollovers can range from a single quarter turn to eight or more quarter turns, with the duration of the rollover crash lasting from one to several seconds. The wide range of rollover conditions occurs because these crashes largely occur off road where the vehicle motion is highly influenced by roadside conditions.

The variety and complexity of real-world rollover crashes create significant challenges in developing dynamic tests suitable for a Federal motor vehicle safety standard. Rollover crash tests can have an undesirable amount of variability in vehicle and occupant kinematics.

In assessing whether a potential dynamic test would be appropriate for a Federal motor vehicle safety standard, the agency must consider such issues as (1) whether the test is representative of real-world crashes with respect what

happens to the vehicle and any specified test dummies; (2) for the specific aspect of performance at issue, whether the test is sufficiently representative of enough relevant real-world crashes to drive appropriate countermeasures and, if not, the number and nature of necessary tests to achieve that purpose; (3) whether the test is repeatable and reproducible so that the standard will be objective; and (4) whether the test dummies to be specified are biofidelic for the purposes used.

We have reviewed the comments recommending a dynamic test and are including our analysis of those comments in an appendix to this document. NHTSA appreciates the information and data that have been provided on this subject. We decline, however, to pursue a dynamic test as part of this rulemaking, or to initiate at this time a separate rulemaking for a dynamic test.

As noted above, we explained in the NPRM that we were unaware of any dynamic test procedure that provides a sufficiently repeatable test environment. After reviewing the public comments and for reasons discussed in the appendix, we continue to take that position. While some commenters argued that certain procedures are repeatable, the agency was not persuaded by the arguments and data they presented. Moreover, for reasons discussed in the appendix, there are significant issues associated with each of the cited dynamic test procedures related to possible use in a Federal motor vehicle safety standard.

Also of importance for this rulemaking, even if NHTSA were to identify a particular dynamic test procedure, among the many known to be available, as likely to be suitable for assessing roof crush resistance (something we have not been able to do thus far), we would need additional years of research to evaluate and refine, as necessary, the procedure to develop a proposal, including evaluating it in the context of the current vehicle fleet. It is also not known whether any dynamic test requirement that might be identified by NHTSA's research would produce significant additional benefits beyond those that will be produced by the substantial upgrade of the quasi-static procedure that we are adopting in this rule.

NHTSA agrees, however, with pursuing a dynamic test as our ultimate goal. We would like to have one for rollover crashes just as we do for front and side crashes. Unfortunately, we cannot adopt or even propose one now because of issues related to test

repeatability, a dummy, and lack of injury criteria. We are pursuing further research for a dynamic test, but we expect that it will take a number of years to resolve these issues. In the meantime, we do not want to delay a significant upgrade of FMVSS No. 216 that will save 135 lives each year.

2. Vehicle Application

FMVSS No. 216 currently applies to passenger cars, and to multipurpose passenger vehicles, trucks and buses with a GVWR of 2,722 kilograms (6,000 pounds) or less. In our August 2005 NPRM, in addition to proposing upgraded performance requirements, we proposed to extend the application of the standard to vehicles with a GVWR of up to 4,536 kilograms (10,000 pounds). We proposed to permit vehicles manufactured in two or more stages, other than chassis-cabs, to be certified to the roof crush requirements of FMVSS No. 220, instead of FMVSS No. 216. We stated that we believed that the requirements of FMVSS No. 220 appeared to offer a reasonable avenue to balance the desire to respond to the needs of multi-stage manufacturers and the need to increase safety in rollover crashes.

The commenters generally supported extending the application of FMVSS No. 216 to vehicles with a GVWR of up to 4,536 kilograms (10,000 pounds). The National Transportation Safety Board (NTSB) stated that heavier vehicles such as 12- and 15-passenger vans, not currently subjected to the standard, are experiencing patterns of roof intrusion greater than vehicles already subject to the requirements. That commenter also cited two investigations it conducted concerning the safety need for vehicles between 6,000 and 10,000 pounds GVWR to meet roof crush resistance requirements.

We received a number of comments concerning requirements for multi-stage vehicles and vehicles with altered roofs, including ones from Advocates, the National Truck Equipment Association (NTEA), the Recreation Vehicle Industry Association (RVIA) and the National Mobility Equipment Dealers Association (NMEDA). The concerns and recommendations of these commenters varied considerably. We discuss and address the comments later in this document. For purposes of this more general section concerning applicability, we note that we are providing a FMVSS No. 220 option for some but not all multi-stage vehicles and for vehicles which are altered in certain ways to raise the height of the roof. We also note that, for reasons discussed in that section, we are excluding a narrow

⁹Viano D., Parenteau C., "Rollover Crash Sensing and Safety Overview," SAE International, 2004-01-0342.

category of multi-stage trucks from FMVSS No. 216 altogether.

Subject to the limited exceptions/alternatives/exclusions noted in the previous paragraph or already included in FMVSS No. 216, and for the reasons discussed in the NPRM and in this document, we are extending the application of the standard to vehicles with a GVWR of up to 4,536 kilograms (10,000 pounds).¹⁰

3. Single-Sided or Two-Sided Tests

Under the current version of FMVSS No. 216, vehicles must meet the standard's requirements for both the driver and passenger sides of the vehicle. Thus, roof crush resistance protection is required for both the driver and passenger sides of the vehicle. The standard specifies a single-sided test. While a vehicle must meet the standard's test requirements, regardless of whether it is tested on the driver or passenger side, a particular vehicle is tested on only one side.

As discussed in the NPRM, a number of commenters on our 2001 RFC suggested that the agency specify a two-sided test requirement, i.e., a requirement that each vehicle must meet the standard's test requirements when tested sequentially, first on one side of the vehicle, and then on the other side. Commenters making this recommendation included Public Citizen and CFIR. The commenters stated that vehicle occupants on the far side of the rollover have a much greater risk of serious injury than occupants on the near side,¹¹ and argued that a two-sided requirement is needed to protect far side occupants.

In the NPRM, the agency summarized the results of six two-sided tests it had conducted in light of those comments. The testing sought to evaluate the strength of the second side of the roof of vehicles whose first side had already been tested. In this testing, after the force was applied to one side of the roof over the front seat area of a vehicle, the vehicle was repositioned and force was then applied on the opposite side of the roof over the front seat area. In performing these tests on both sides of a vehicle, the agency used the platen angle currently specified in FMVSS No. 216 (5 degree pitch forward and 25 degree rotation outward, along its lateral axis). We concluded that the strength of

the roof on the second side of some vehicles may have been increased or decreased as a result of the deformation of the first side of the roof. The agency indicated that it planned to conduct further research before proposing rulemaking in this area.

In commenting on the NPRM, a number of consumer advocacy organizations and other commenters strongly supported a two-sided test requirement. These commenters included, among others, Public Citizen, CFIR, CAS, and Advocates. Supporters of a two-sided test requirement argued that more damage occurs to the far (or trailing) side of the vehicle in a rollover crash, and a two-sided test would better reflect this real-world intrusion. They further argued that when the near side roof and windshield are compromised in a rollover, the far side will not be able to withstand the forces of the event, and, consequently, facilitate roof collapse. ARCCA, Inc., Consumers Union, and Safety Analysis and Forensic Engineering (SAFE) suggested a two-sided test would simulate the impact that occurs in the majority of rollover incidents.

In light of the substantial interest in a two-sided test requirement, NHTSA expanded the series of two-sided roof crush tests discussed in the NPRM. In our January 2008 SNPRM, we explained that we had, by that time, conducted a total of 26 sequential two-sided tests, and announced that we were releasing these data to the public in conjunction with the SNPRM.

We stated in the SNPRM that the two-sided test results showed the first side test generally produces a weakening of the structure. This was shown by the fact that the recorded SWR for the second side was generally lower than for the first side. On average, the peak strength for the second side was reduced by 8.7 percent. However, for several of the vehicles, we observed considerably higher reductions in peak strength. Of the 26 vehicles that had been tested by that time, excluding the Chevrolet Express, six experienced reductions in strength of 19 percent or greater. We excluded the Chevrolet Express because of a test anomaly.¹²

With respect to two-sided vehicle testing, we stated that we believed that the post-NPRM tests provided the agency with sufficient additional

information for the agency to consider a two-sided test requirement for the final rule. We stated that we would evaluate both the single-sided and two-sided testing alternatives for the final rule, and requested comments to help us reach a decision on that issue.

Comments

In commenting on the SNPRM, a number of consumer advocacy organizations continued to strongly support a two-sided test requirement. Public Citizen stated that in a vast majority of rollover cases, the injured party was typically seated on the far side, that is, the side of the second impact. It argued that it is not possible to upgrade FMVSS No. 216 without a two-sided test requirement. Some commenters argued, as they had in commenting on the NPRM, that they believe SAFETEA-LU requires a two-sided test.

IIHS stated that while it supports any changes that would increase the level of roof strength of the vehicle fleet, it has no real-world data to address the potential benefits of two-sided testing. It stated that a single-sided test with a higher SWR may be more effective at promoting robust roof designs than a two-sided test with a lower SWR requirement.

The Alliance stated that it believes the agency has provided insufficient justification for two-sided testing. It stated that the agency has not provided analysis demonstrating that two-sided testing relates to real-world safety.

The Alliance also expressed concern that two-sided testing would amplify variability and repeatability problems. That organization argued that the agency's limited repeatability testing for a potential two-sided requirement indicates poor repeatability in SWR between the first and second side tests for the same vehicle. The Alliance cited agency tests of the Lincoln LS and Buick LaCrosse.

According to the Alliance, these differences may be due solely to lack of test procedure repeatability and test lab reproducibility, rather than any real weakening or strengthening of the roof structure due to the first side test. That commenter stated that in a two-sided scenario, the deformed shape of a vehicle tested for roof strength on one side between any two tests is not identical. The starting point for the roof-strength testing on the second side is therefore, according to the Alliance, inherently different and results in substantial variability in measured roof strength.

AIAM stated that based on the information and analysis provided by

¹⁰ This final rule will address the NTSB's recommendation H-03-16, to include 12- and 15-passenger vans in FMVSS No. 216, to minimize the extent to which survivable space is compromised in the event of a rollover accident.

¹¹ Near side is the side toward which the vehicle begins to roll and the far side is the trailing side of the roll.

¹² Between the first and second side tests, the front door on the tested side was opened. Because of damage to the vehicle during the first side test, the door would not properly close. The door was clamped until the latch engaged, locking the door in place. This may have compromised the structural integrity of the roof and reduced the measured peak load on the second side.

the agency regarding the two-sided test, it believes that the test shows enough potential to merit further consideration by the agency. AIAM argued that additional analysis would be needed before it could provide a preferred regulatory approach, but indicated that the two-sided approach would more directly address the multiple roof contact weakening phenomenon.

Agency Response

After carefully considering the comments and available information, we have decided, for the reasons discussed below, to adopt a two-sided test requirement.

In responding to the comments, we begin by addressing the argument raised by some commenters that SAFETEA-LU requires a two-sided test. Public Citizen stated that the agency has "ignored the express requirement of a two-sided test." That organization cited the statutory language requiring NHTSA to upgrade FMVSS No. 216 related to roof strength "for driver *and* passenger *sides*." (Emphasis added by Public Citizen.)

As discussed earlier in this document, under the current version of FMVSS No. 216, vehicles must meet the standard's requirements for both the driver and passenger sides of the vehicle, i.e., a vehicle must meet the standard's test requirements regardless of whether it is tested on the driver or passenger side. Thus, while the standard specifies a single-sided test, roof crush resistance protection is required for both the driver and passenger sides of the vehicle. Similarly, upgrading the current performance requirements so that vehicles must provide protection at a significantly higher SWR under a single-sided test procedure would result in upgraded protection for both the driver and passenger sides. Thus, while we understand the safety arguments raised by Public Citizen and other commenters favoring a two-sided test, we believe that the language in SAFETEA-LU does not mandate a two-sided test requirement, only that upgraded protection be provided for both the driver and passenger sides.

We also note that the issue of whether to adopt a two-sided test is related to the decision of what stringency to adopt. For any baseline single-sided test requirement at a particular SWR, either increasing the SWR for the single-sided test or adding a two-sided test requirement at the same SWR would represent an increase in stringency. Therefore, in reaching a decision on these issues, we have considered them together.

To help evaluate the merits of a two-sided test requirement, the agency analyzed 1997 through 2006 NASS-CDS rollover crash data, involving restrained occupants.¹³ Only vehicles that overturned and experienced 2 or more quarter turns were included. This study included 4,030 NASS-CDS investigated vehicles, and excluded convertibles and vehicles that had a concentrated loading due to a collision between a fixed object (pole or tree) and the roof.

The data were analyzed for differences in injury risk for the near and far side occupants and also to ascertain any disparity in the amount of roof intrusion. For all rollovers involving two or more quarter turns, the data showed that there are a similar number of near and far side occupants involved in the event. A further review of the injury outcomes showed that the injuries to far side occupants occur at a slightly higher frequency than injuries to near side occupants.

The occupant injury data were further analyzed to determine whether the relative proportion of near and far side injured occupants varied with the amount of roof intrusion. The injury outcomes for occupants in vehicles with less than 12 cm (5 inches) of near side roof intrusion show higher frequency of injury for the far side occupant at the various injury levels. The outcomes for injured occupants in vehicles with 12 cm (5 inches) or greater near side intrusion have similar percentages of severe injuries between near and far occupants. Based on this analysis, the data indicate there may be some higher risk for far side occupants at lower levels of intrusion; however, none of the results was statistically significant.

The analysis investigated the difference in roof intrusion between the near and far side of the vehicle that experienced two quarter turns or more. For the 4,030 NASS-CDS vehicles, there was a weighted average maximum vertical intrusion of 7.9 cm (3.1 inches) on the near side and 10.9 cm (4.3 inches) on the far side of the rollover-involved vehicle. The far side of the vehicle averaged 3 cm (1.2 inches) more vertical intrusion than the near side.

The analysis also investigated the intrusion difference between the near and far side grouped by the severity of the rollover. (Severity of the rollover was defined by single or multiple roof-to-ground contacts). The data showed a 3 cm (1.2 inch) bias toward the far side intrusion, independent of the severity of the rollover. For example, vehicles experiencing five or more quarter turns

had 9.2 cm (3.6 inches) of near-side intrusion compared to 12.2 cm (4.8 inches) of far-side intrusion. The analysis concluded for crashes with multiple roof-to-ground contacts (or severe rollovers), there is a statistically insignificant bias on the far side.

Since the publication of the SNPRM, the agency has conducted an additional five tests¹⁴ as part of its evaluation, for a total of 31 two-sided tests.¹⁵ The test results for all 31 two-sided tests are summarized in Appendix B of this document.

On average, the peak strength for the second side was reduced by 8.4 percent. This reduction in strength is consistent with our NASS-CDS analysis, showing a slight increase of intrusion on the second side. This also may explain the increased risk to injury for far side occupants. In all the tests, the windshield fractured during the first side test and there was not a catastrophic collapse of the roof on the second side.

In general, there was a good correlation in peak strength between the first and second side. The agency did test four vehicles that resulted in increased strength on the second side. However, for several of the vehicles, we observed considerably higher reductions in peak strength. Of the 31 vehicles tested, again excluding the Chevrolet Express, seven experienced reductions in strength of 19 percent or greater. The two-sided testing conducted by NHTSA indicated an average difference of approximately 7.1 percent lower peak force for the second side in vehicles under 2,722 kilograms (6,000 pounds) GVWR and 14.9 percent lower peak force for the second side in vehicles over 2,722 kilograms (6,000 pounds) GVWR.

We have decided to adopt a two-sided test in light of several considerations. First, we believe a two-sided test is more representative of the higher severity rollover crashes in which a vehicle experiences multiple quarter turns. In such crashes, the vehicles sometimes experiences a significant impact on one side of the vehicle and,

¹⁴ The test reports for the additional vehicle tests conducted by NHTSA are being made available to the public through the agency's internet vehicle crash test database. We are placing a memorandum in the docket which provides the Web address for that database and lists the vehicle models and test numbers that are needed to reference the information in the database. The agency incorporates by reference these test reports as part of the record for this rulemaking.

¹⁵ We note that we also conducted a test of a Smart ForTwo. However, we did not include these test results as part of our evaluation because the vehicle is not typical of a significant number of vehicles in the fleet.

¹³ See report *Evaluation of 2 Side Roof Crush Testing* placed in the docket with this notice.

as the vehicle continues to turn, another significant impact on the other side of the vehicle. A two-sided test will help ensure that the impact on the first side of the vehicle does not cause excess damage that will prevent the vehicle from providing protection during the impact on the second side of the vehicle.

Moreover, as discussed in the FRIA, the greater stringency associated with a two-sided test requirement will provide greater benefits.

While we recognize that a two-sided test requirement affects the stringency of the standard, as compared to a single-sided test requirement at the same SWR, we believe that it does not raise concerns related to test procedure repeatability and test lab reproducibility.

In addressing this issue, we note that the test conducted on the second side is identical to the test conducted on the first side. Thus, the second side test by itself is repeatable and reproducible, for the same reasons the first side test is repeatable and reproducible.

As noted by the Alliance, the “starting point” for the second side test is different than for the first side test in that the vehicle may have experienced damage during the first side test. However, it is the purpose of a two-sided test requirement to limit such damage, to the extent such damage would prevent compliance with the standard’s performance requirements during the second side test.

As to the Lincoln LS and Buick Lacrosse repeat tests cited by the Alliance, the change in peak SWR between the first and second side test was –21.3 percent and –8.7 percent for the two Lincoln LS vehicles tested, and –13.5 percent and –3.4 percent for the two Buick Lacrosse vehicles tested. For the Lincoln LS, there was good correlation between the load-deformation curves on the first side in the two tests. However, on the second side, the load-deformation curves diverge prior to the peak SWR. Further, in one Lincoln LS test, the second side correlated well with the first side. The other test did not show the same correlation on the second side, which led us to believe internal structural damage to the roof during the first side test was the cause. With respect to the Buick Lacrosse, the agency identified a pre-test windshield crack as the likely reason for the difference in outcome between the two tests. The load-deformation curves for the first side did not reach the same peak load; however, there is good correlation on the second side. Thus, we believe the differences

relate to vehicle performance instead of test procedure issues.

It is important to note that the Lincoln LS and Buick Lacrosse vehicles were not subject to an FMVSS incorporating a two-sided requirement or an SWR requirement above 1.5, so they were not designed to meet such a requirement (two-sided test requirement at the tested SWR). Manufacturers can ensure that a vehicle meets a two-sided test requirement by designing it so that they will be able to meet the second-side test despite whatever damage may occur in the first side test. As a general matter, the greater the structural damage that occurs in the first-side test, the greater the variability one would expect in the second-side test. We note that the performance requirement is not expressed in terms of the percentage difference in damage between the first-side test and the second test; instead, the vehicle must meet the same specified performance criteria in both tests. We also note that the first-side test is conducted only up to the SWR specified in the standard.

Finally, we note that issues raised by commenters concerning varying platen angle and size for the second-side test are addressed later in this document in the section addressing aspects of the test procedure.

4. Upgraded Force Requirement—Specified Strength to Weight Ratio (SWR)

As discussed earlier, FMVSS No. 216 currently requires that the lower surface of the test platen not move more than 127 mm (5 inches), when it is used to apply a force equal to 1.5 times the unloaded vehicle weight to the roof over the front seat area. In the NPRM, the agency proposed to require that the roof over the front seat area withstand a force increase equal to 2.5 times the unloaded weight of the vehicle, and to eliminate the 22,240 Newton (5,000 pound) force limit for passenger cars.

NHTSA explained that it believes that FMVSS No. 216 could protect front seat occupants better if the applied force requirement reduced the extent of roof crush occurring in real world crashes. That is, the increased applied force requirement would lead to stronger roofs and reduce the roof crush severity observed in real world crashes. We observed that in many real-world rollovers, vehicles subject to the requirements of FMVSS No. 216 experienced vertical roof intrusion greater than the test plate movement limit of 127 mm (5 inches).

In explaining the proposed 2.5 value for SWR, the agency noted that it

previously conducted a study¹⁶ (Rains study) that measured peak forces generated during quasi-static testing under FMVSS No. 216 and under Society of Automotive Engineers (SAE) J996 inverted drop testing. In the Rains study, nine quasi-static tests were first conducted. The energy absorption was measured and used to determine the appropriate corresponding height for the inverted drop conditions. Six of the vehicles were then dropped onto a load plate. The roof displacement was measured using a string potentiometer connected between the A-pillar and roof attachment and the vehicle floor. The peak force from the drop tests was limited to only the first 74 mm (3 inches) of roof crush because some of the vehicles rolled and contacted the ground with the front of the hood. Similarly, the peak quasi-static force was limited during the first 127 mm (5 inches) of plate movement.

This report showed that for the nine quasi-static tests, the peak force-to-weight ratio ranged from 1.8 to 2.5. Six of these vehicle models were dropped at a height calculated to set the potential energy of the suspended vehicle equal to the static tests. For these dynamic tests, the peak force-to-weight ratio ranged from 2.1 to 3.1. In sum, the agency tentatively concluded that 2.5 was a good representation of the observed range of peak force-to-weight ratio.

As to eliminating the 22,240 Newton force limit for passenger cars, the agency noted that the limit was included when the standard was first issued. The effect of the limit was that passenger cars weighing more than 1,512 kilograms (3,333 pounds) were subjected to less stringent requirements. The purpose of the limit was to avoid making it necessary for manufacturers to redesign large cars that could not meet the full roof strength requirements of the standard.¹⁷ At the time, the agency believed that requiring larger passenger cars to comply with the full (1.5 times the unloaded vehicle weight) requirement would be unnecessary because heavy passenger cars had lower rollover propensity. However, as discussed in the NPRM, the agency tentatively concluded that occupants of passenger cars weighing more than 1,512 kilograms (3,333 pounds) are sustaining rollover-related injuries and that those cars should be able to comply with the proposed requirements.

¹⁶ Glen C. Rains and Mike Van Voorhis, “Quasi Static and Dynamic Roof Crush Testing,” DOT HS 808–873, 1998.

¹⁷ See 54 FR 46276.

The agency stated in the NPRM that it believed that manufacturers would comply with the upgraded standard by strengthening reinforcements in roof pillars, by increasing the gauge of steel used in roofs or by using higher strength materials.

In the SNPRM, we noted that we had been carefully analyzing the numerous comments received in response to the proposal, and the various additional vehicle tests conducted after publication of the NPRM. We invited comments on how the agency should factor in this new information into its decision. We stated that while the NPRM focused on a specified force equivalent to 2.5 times the unloaded vehicle weight, the agency could adopt a higher or lower value for the final rule.

In the SNPRM, we observed from the recent vehicle testing (focusing on the single-sided test results) that the range of SWRs for vehicles with a GVWR of 2,722 kilograms (6,000 pounds) or less tended to be higher than the range of SWRs for vehicles with a GVWR greater than 2,722 kilograms (6,000 pounds). The SWR of many late model vehicles with a GVWR of 2,722 kilograms (6,000 pounds) or less was substantially higher than the 2.5 value the agency focused on in the NPRM. Conversely, only two vehicles we tested with a GVWR greater than 2,722 kilograms (6,000 pounds) exceeded the 2.5 value.

We noted in the SNPRM that the PRIA had examined the proposed SWR of 2.5 and the alternative SWR of 3.0 times the unloaded vehicle weight. The agency included in the SNPRM discussion and analysis concerning a number of factors expected to change the estimated impacts, and sought comments concerning impacts of SWR levels of 2.5, 3.0 and 3.5.

Comments on the NPRM

In general, vehicle manufacturers supported an SWR of 2.5, while safety advocacy groups recommended a more stringent standard with the majority supporting a 3.5 SWR requirement.

Vehicle manufacturers, including General Motors Corporation (GM), Ford Motor Company (Ford), DaimlerChrysler Corporation,¹⁸ Porsche Cars North America (Porsche), Toyota Motor North America (Toyota), and Nissan North America (Nissan), and the Alliance supported the proposed 2.5 SWR level, with caveats about sufficient leadtime and other requested changes to the test

procedure, but expressed concern about raising the SWR further. The Alliance cautioned against increasing the SWR beyond 2.5 due to the potential adverse effects of increased mass. It stated that recommendations in the docket for higher levels did not attempt to account for the potential effect on the static stability factor (SSF) of adding structure necessary to comply with higher standards.

Commenters supporting a 3.5 SWR included Lipsig, Shapey, Manus & Moverman (LSMM), Consumers Union, Center for the Study of Responsive Law (CSRL), Mr. Sances, Perrone Forensic Consulting (Perrone), Ms. Lawlor, Mr. Clough, Xprts, Mr. Nash, Mr. Friedman, and Forensic Engineering (FEI). Consumers Union, LSMM, Ms. Lawlor, Mr. Clough, and Mr. Sances supported a 3.5 SWR based on, among other things, the performance of the Volvo XC90. Commenters stated that the Volvo XC90 has heightened roof strength resistance through light-weight materials making it possible to avoid any unnecessary increases in vehicle weight which could adversely affect rollover propensity. In supporting more stringent roof crush resistance requirements, the CSRL stated that NHTSA should consider using its technology-forcing authority.

Several commenters supported an SWR of 4.0 or higher. These commenters included Mr. Slavik, ARCCA, Technical Services, and FEI. The commenters suggested that higher strength steel alloy, changes to the cross sectional thickness of roof components, and other design changes would make increasing the SWR feasible and cost effective.

In connection with arguments that the agency should base the level of the standard on the performance of the Volvo XC90, Ford commented that in considering the stringency of an SWR requirement, roof SWR does not discriminate vehicles by roof strength. It noted that the roof strength required to achieve a specific SWR depends on the vehicle's unloaded vehicle weight (UVW). Ford stated that two vehicles with the same SWR, but different UVWs, may have roof strength levels that are actually several thousand pounds apart. That company argued that the agency's 2.5 SWR proposal is very stringent. Ford stated that vehicle roof designs are essentially the same for all passenger carrying vehicles, and that A pillars are A pillars and B pillars are B pillars, regardless of vehicle type, i.e., the constraints on a roof system design are applicable to all affected vehicles. That company argued that because a particular vehicle can achieve a roof

SWR of 3.5, because it has a lower UVW as compared to a full size pickup, does not mean that 3.5 should be the regulatory requirement.

Comments on the SNPRM

In commenting on the SNPRM, vehicle manufacturers continued to support an SWR of 2.5, with safety advocacy groups recommending a more stringent requirement.

The Alliance recommended that all vehicles should be held to the same requirements and that a separate requirement should not be afforded for heavy vehicles. Mercedes-Benz suggested that, for a two-sided test requirement, the SWR on the second side should be lower than what would be required for the first side. This would reflect the lower force levels in a rollover that it said the second side would experience.

IIHS supported raising the SWR to 3.0 or higher in a one-sided test. IIHS stated that its new analysis justifies such a requirement.

Agency Decision and Response

After carefully considering the comments and available information, and for the reasons discussed below, we have decided to adopt an SWR requirement of 3.0 for vehicles with a GVWR of 2,722 kilograms (6,000 pounds) or less, and 1.5 for vehicles with a GVWR greater than 2,722 kilograms (6,000 pounds).

While this rulemaking involves a number of key decisions, the selection of an SWR requirement is the most important one for both costs and benefits. Our analysis, presented in detail in the FRIA, shows that for the alternatives we evaluated, benefits in terms of reduced fatalities continue to rise with higher SWR levels due to reduced intrusion. The benefits continue to rise because, for vehicles designed to have higher SWR levels, the vehicle roofs experience less intrusion in higher severity crashes. However, costs also increase substantially with higher SWR levels, so NHTSA must select the appropriate balance of safety benefits to added costs.

Under the Safety Act, NHTSA must issue safety standards that are both practicable and meet the need for motor vehicle safety. 49 U.S.C. 30111(a). The agency considers economic factors, including costs, as part of ensuring that standards are reasonable, practicable, and appropriate.

In *Motor Vehicle Manufacturers Association v. State Farm*, 463 U.S. 29, 54–55 (1983), the Supreme Court indicated that the agency must, in making decisions about safety

¹⁸In August 2007, Daimler and Chrysler separated. All comments submitted to the agency prior to that date will be noted in this document as DaimlerChrysler. Mercedes-Benz USA and Chrysler LLC submitted comments separately afterwards and will be referenced accordingly.

standards, consider reasonableness of monetary and other costs associated with the standard. It stated, however, that "(i)n reaching its judgment, NHTSA should bear in mind that Congress intended safety to be the preeminent factor under the Motor Vehicle Safety Act."

The Committee intends that safety shall be the overriding consideration in the issuance of standards under this bill. The Committee recognizes * * * that the Secretary will necessarily consider reasonableness of cost, feasibility and adequate leadtime. S. Rep. No. 1301, at 6, U.S. Code Cong. & Admin. News 1966, p. 2714.

In establishing standards the Secretary must conform to the requirement that the standard be practicable. This would require consideration of all relevant factors, including technological ability to achieve the goal of a particular standard as well as consideration of economic factors. Motor vehicle safety is the paramount purpose of this bill and each standard must be related thereto. H.Rep. No. 1776, at 16.

Thus, in making our decision concerning SWR, we are guided by the statutory language, legislative history, and the Supreme Court's construction of the Safety Act, as well as by the specific requirement in SAFETEA-LU for us to upgrade FMVSS No. 216 relating to roof strength for driver and passenger sides for motor vehicles with a GVWR of not more than 4,536 kilograms (10,000 pounds). We consider both costs and benefits, bearing in mind that Congress intended safety to be the preeminent factor under the Safety Act.

As indicated above, while benefits continue to rise with higher SWR levels, costs also increase substantially. The challenge is to push to a level where the safety benefits are still reasonable in relation to the associated costs. As part of this, we consider issues related to cost effectiveness. The agency's analysis of cost effectiveness is presented in the FRIA and summarized in this document.

Another important factor in the selection of the SWR requirements is that there are much higher costs relative to benefits associated with any level SWR requirement for vehicles with a GVWR greater than 2,722 kilograms (6,000 pounds) as compared to the lighter vehicles currently subject to the standard.

There are a number of reasons for this differential between heavier and lighter vehicles. The absolute strength needed to meet a specific SWR is a function of the vehicle's weight. By way of example, to meet a 2.0 SWR, a vehicle that weighs 1,360 kilograms (3,000 pounds) must have a roof structure capable of withstanding 26,690 N (6,000 pounds) of force, while a vehicle that

weighs 2,268 kilograms (5,000 pounds) must have a roof structure capable of withstanding 44,482 N (10,000 pounds) of force. This means more structure or reinforcement are needed for the heavier vehicle, which means more cost and weight. Moreover, vehicles in the heavier category have not previously been subject to FMVSS No. 216, so they have not been required to meet the existing 1.5 SWR single-sided requirement.

At the same time, these heavier vehicles account for only a very small part of the target population of occupants who might benefit from improved roof strength. Only 5 percent of the fatalities in the overall target population (33 in terms of a specific number) occur in vehicles over 2,722 kilograms (6,000 pounds) GVWR. Ninety-five percent of the fatalities (635 in terms of a specific number) occur in vehicles *under* 2,722 kilograms (6,000 pounds) GVWR. These differences reflect the fact that there are far fewer vehicles in this category in the on-road fleet, and may also reflect the vehicles' size and weight as well as their frequency of use as working vehicles. Heavier vehicles generally are less likely to roll over than lighter vehicles.

We recognize the argument that all light vehicles should meet the same SWR requirements, to ensure the same minimum level of protection in a rollover crash. However, in selecting particular requirements for a final rule, we believe that our focus must be on saving lives while also considering costs and relative risk. What is necessary to meet the need for safety and is practicable for one type or size of vehicle may not be necessary or reasonable, practicable and appropriate for another type or size of vehicle. Thus, to the extent the goal of establishing the same SWR requirements for all light vehicles would have the effect of either unnecessarily reducing the number of lives saved in lighter vehicles or imposing substantially higher, unreasonable costs on heavier vehicles despite their lesser relative risk, we believe it is appropriate to adopt different requirements for different vehicles. We also observe that because the same SWR requirement is significantly more stringent for heavier vehicles than lighter vehicles (due to SWR being a multiple of unloaded vehicle weight), establishing the same SWR requirement for heavier vehicles is not simply a matter of expecting manufacturers to provide the same countermeasures as they do for light vehicles.

Vehicles with a GVWR of 2,722 kilograms (6,000 pounds) or less.

Our decision to adopt a 3.0 SWR requirement for vehicles with a GVWR of 2,722 kilograms (6,000 pounds) or less, i.e., the vehicles currently subject to the standard, reflects the higher life-saving benefits associated with that requirement. It also reflects our consideration of the test results of current vehicles. We believe the high SWR levels that are currently being achieved for a range of light vehicles demonstrate that manufacturers can achieve this SWR level for these vehicles.

An SWR requirement of 3.0 prevents about 66 percent more fatalities than one at 2.5, 133 instead of 80. However, costs increase by a considerably higher percentage, resulting in a less favorable cost per equivalent life saved, \$5.7 million to \$8.5 million for 3.0 SWR as compared to \$3.8 million to \$7.2 million for 2.5 SWR.

In these particular circumstances, we believe that a 3.0 SWR requirement is appropriate and the costs reasonable given the increased benefits. While the cost per equivalent life saved is relatively high compared to other NHTSA rulemakings, we conclude that the higher safety benefits, the legislative mandate for an upgrade, the technical feasibility of making roofs this strong, and the fact that these costs are generally within the range of accepted values justify moving NHTSA's roof crush standards to a 3.0 SWR for vehicles that have been subject to the 1.5 SWR requirements.

We decline, however, to adopt an even higher SWR requirement. In considering higher SWR requirements at this level, costs continue to increase at a considerably higher rate than benefits. The FRIA estimates that while a 3.5 SWR requirement for these vehicles would result in higher benefits, preventing 175 instead of 133 fatalities, total costs would increase to \$1.6 billion to \$2.3 billion (about \$800 million to \$1.1 billion above the total costs for the 3.0 SWR requirement) and the overall cost per equivalent life saved for these vehicles would increase to \$8.8 to \$12.3 million. A 3.5 SWR requirement would thus result in an approximate doubling of the costs beyond those of a 3.0 SWR requirement, and deliver about 1/3 more benefits.

Vehicles with a GVWR greater than 2,722 kilograms (6,000 pounds) and less than or equal to 4,536 kilograms (10,000 pounds).

Vehicles with a GVWR greater than 2,722 kilograms (6,000 pounds) are not currently subject to FMVSS No. 216 and, because of their greater unloaded vehicle weight, these vehicles pose greater design challenges. Moreover,

given the relatively small target population for these vehicles, the benefits will necessarily be small regardless of the SWR selected.

After considering our original proposal of a SWR of 2.5 and the available information, we have concluded that a SWR of 1.5 is appropriate for these heavier vehicles. The requirement we are adopting is more stringent than the longstanding requirement that has applied to lighter vehicles until this rulemaking because it is a two-sided requirement. The FRIA estimates that two fatalities and 46 nonfatal injuries will be prevented annually by this requirement. Because of the high cost relative to the benefits for all of the alternatives for these heavier vehicles, from the 1.5 SWR alternative and above, any alternative we select would adversely affect the overall cost effectiveness of this rulemaking (covering all light vehicles).

We believe that a SWR of 1.5 is appropriate for these heavier vehicles. Given the requirements of SAFETEA-LU, we need to ensure that the standard results in improved real world roof crush resistance for these vehicles. We decline, however, to adopt a SWR higher than 1.5 for vehicles with a GVWR greater than 2,722 kilograms (6,000 pounds), given the small additional benefits (4 additional lives saved) and substantially higher costs. Adopting a SWR of 2.0 for these vehicles would more than double the costs of this rule for these vehicles to prevent 4 additional fatalities and 137 nonfatal injuries.

Other issues related to strength requirements and SWR.

As indicated above, the Alliance cautioned against increasing the SWR beyond 2.5 for lighter vehicles due to the potential adverse effects of increased mass. It stated that recommendations in the docket for higher levels did not attempt to account for the potential effect on the SSF of adding structure necessary to comply with higher standards.

We do not believe that it is necessary to account for that effect. We note that the agency has considered a number of issues related to added weight as part of the FRIA, including possible adverse effects to safety. Based on our analysis, we believe that today's rule will not result in adverse effects to safety as a result of added weight.

For a number of reasons, including ones related to CAFE standards, fuel prices, and rollover propensity, we believe manufacturers will strive to minimize the weight impacts of added roof strength. While there is a great deal of uncertainty regarding the actual

changes that manufacturers will initiate in response to this rule, there are numerous ways to address both roof strength and rollover propensity simultaneously. This final rule provides substantial leadtime within which to choose among those ways and make design changes that avoid adversely affecting that propensity. There is evidence from current NCAP ratings that manufacturers are routinely doing so. Manufacturers generally strive to maintain or improve their NCAP ratings to help market their vehicles. The agency believes that this concern over NCAP ratings would preclude a design strategy that unnecessarily increases CG and degrades SSF. Further, agency testing of 10 redesigned vehicles with higher roof strengths found that manufacturers had maintained SSF levels while increasing roof strength in newly redesigned models.

A detailed discussion of issues related to added weight and SSF is included in the FRIA, and there is also additional discussion later in this document.

Mercedes-Benz suggested that, for a two-sided test requirement, the SWR on the second side should be lower than what would be required for the first side. According to Mercedes, this would reflect the lower force levels in a rollover that it said the second side would experience. However, as discussed above in the section on single-sided or two-sided tests, the agency's analysis of NASS data indicates that vehicles experience more intrusion on the far side (second side) of the vehicle than the near side. Therefore, we decline to adopt a lower SWR requirement for the second side. We note that the agency took into account the costs and benefits of a two-sided test requirement with the SWR at the same level for both sides.

As to the issue raised by CSRL about safety standards that are technology-forcing, that commenter did not provide specific information concerning what it contemplated in this area. As part of the agency's analysis of costs and benefits, we considered the use of advanced higher strength and lighter weight materials. Our analysis assumes significantly greater implementation and use of these advanced materials.

Finally, we note that several commenters suggested that the agency use alternative approaches other than unloaded vehicle weight for purposes of calculating SWR. Recommendations included using weight of the vehicle plus two occupants, or GVWR plus two occupants. We decline to change FMVSS No. 216's existing approach of using a multiple of unloaded vehicle weight for calculating the force

requirement that applies to each vehicle. Using a weight higher than unloaded vehicle weight would simply represent another means of increasing stringency and would be equivalent to a requirement for a higher SWR. However, the agency has already considered alternative higher SWR levels, as well as a two-sided test requirement, which also represent an increase in stringency. Thus, the other issues we have considered ensure an appropriate level of stringency.

5. Performance Criteria—Headroom, Platen Travel, or Both

In the NPRM, we proposed to replace the current limit on platen travel (test plate movement) during the specified quasi-static test with a requirement that the crush not exceed the available headroom. We were concerned that the platen travel limit does not provide adequate protection to front outboard occupants of vehicles with a small amount of occupant headroom. We also stated that the current requirement may impose a needless burden on vehicles with a large amount of occupant headroom.

Under our proposal, no roof component or portion of the test device could contact the head or neck of a seated Hybrid III 50th percentile adult male dummy during the specified test. We believed that this direct headroom reduction limit would ensure that motorists receive an adequate level of roof crush protection regardless of the type of vehicle in which they ride. We included a definition of the term "roof component" as part of the proposal.

We noted a concern that there may be some low roofline vehicles in which the 50th percentile Hybrid III dummy would have relatively little available headroom when positioned properly in the seat. That is, we were concerned that, in some limited circumstances, the headroom between the head of a 50th percentile male dummy and the roof liner is so small that even minimal deformation resulting from the application of the required force would lead to test failure. We requested comments on whether any additional or substitute requirements would be appropriate for low roofline vehicles.

In the NPRM, the agency estimated benefits based on post-crash headroom, the only basis for which a statistical relationship with injury reduction had been established. In our January 2008 SNPRM, we explained that with additional years of available data, a statistically significant relationship between intrusion and injury for belted occupants had been established. A

study regarding this relationship was placed in the docket.¹⁹

We also noted in the January 2008 SNPRM that in the most recent agency testing, headroom reduction had been assessed using a head positioning fixture (HPF) in lieu of a 50th percentile adult male dummy. We stated that reports on these tests explain the procedure and type of fixture used to assess headroom reduction, and that the test reports were being made available to the public. We noted further that the agency was considering whether this fixture should be specified in the final rule.

Comments

The agency received a variety of comments on the proposed headroom reduction criterion.

One group of commenters, including safety advocacy organizations, generally supported adding a headroom reduction criterion but, in some cases, argued that a platen travel criterion is also needed. Some of these commenters also argued that these criteria should be made more stringent to protect taller occupants.

Another group of commenters, including vehicle manufacturers, urged the agency to retain the current platen travel criterion instead of adopting a headroom reduction criterion. They argued, among other things, that using the headroom reduction criterion would add unnecessary complexity to the test procedure and result in problems related to repeatability and practicability.

Specific issues raised by commenters include:

Repeatability and practicability issues. Several commenters, including the Alliance, DaimlerChrysler, GM, Ford, and Porsche, cited concerns related to reliability and practicability of using a test dummy for purposes of the FMVSS No. 216 quasi-static test. DaimlerChrysler, Ford and GM stated that variations in test dummy placement cause variability in the distance between the dummy head and the roof side rails. In test results cited by GM, horizontal and vertical variations of an inch or more occurred in the dummy's seating position. GM stated that this variability is further complicated when vehicles with different trim and seating options (cloth or leather, manual or power adjusters) are provided using the same vehicle architecture structure. It suggested that such options add to the variability and make the proposed

requirement of measuring roof crush resistance with a seated Hybrid III dummy non-repeatable and impracticable.

Porsche also expressed concern with controlling unwanted movement of the dummy with its roof crush test set-up. The Porsche roof crush test procedure rotates the vehicle by 90 degrees because their platen press applies a load parallel to the ground. The dummy is not fixed into position and, as a result, would rotate and not be properly positioned.

Complexity. IIHS stated that relating the allowable amount of roof crush in the quasi-static test to the headroom in specific vehicles is a good concept but that, in practice, the agency's research tests have not shown that replacing the 127 mm (5 inch) platen travel criterion with the headroom requirement would be a meaningful change to the standard and may not justify the added complications to the test procedure.

Possible conflicts with FMVSS No. 201 "Occupant protection in interior impact." A number of commenters, including DaimlerChrysler, Ford, GM, Ferrari and Toyota commented that the proposed headroom requirement conflicts with the intent of the upper interior requirements of FMVSS No. 201, *Occupant Protection in Interior Impact*. DaimlerChrysler and GM stated that FMVSS No. 201U²⁰ countermeasures have been specifically developed to manage head impact energy and mitigate injury potential by the dissipation of the impact energy through deformation of the trim and FMVSS No. 201U countermeasures themselves. Ford stated that head impact mitigation technologies often result in the upper interior trim, particularly the roof side rail trim, being closer to the head of occupants, thereby reducing the available distance for achieving the SWR requirement prior to headform contact. It stated that these technologies are designed to reduce the likelihood of head impact injuries, and that the proposed no-contact requirement does not account for the potential benefits of these technologies in a roof deformation situation. GM further stated that NHTSA's headroom analysis does not establish a correlation between injuries and head contact with trim components.

Effects on vehicle manufacturing process GM stated that since the vehicle roof structure is designed very early in the vehicle development process, it is not possible to reliably predict the

performance or movement of interior trim in a roof crush test. It stated that structural designs must be completed early in the vehicle development process to facilitate tooling lead time. According to GM, the interior trim components (included in the proposed definition of roof component) are not designed in final form until much later in the vehicle development process. Therefore, according to that commenter, the roof structure force deflection characteristics are defined (and roof crush properties established) before manufacturers can take into account the package space and deformation requirements of the interior trim.

Reduced stringency of the standard Several commenters, including Public Citizen, IIHS, and LSMM expressed concern that the proposed head contact criteria could reduce the residual occupant headroom required after testing, be less stringent for vehicles with existing headroom greater than 127 mm (5 inches), and thereby allow more than 127 mm (5 inches) of crush. As a result, according to these commenters, the stringency would be reduced for vehicles with greater than 127 mm (5 inches) of headroom, such as many trucks and Sport Utility Vehicles (SUVs). We note that Ford commented that most of its light trucks, multipurpose passenger vehicles and vans (LTVs) have more than 127 mm (5 inches) of platen travel prior to head contact, while passenger cars generally have less.

Alternative headroom requirement approaches A number of commenters recommended alternative approaches to the proposed headroom requirement. Biomech Incorporated (Biomech) suggested using a one gravity static inversion test (using the FMVSS No. 301 fixture) to learn where the inverted dummy head position would be. It suggested that deformation in the roof crush test should not be permitted to reach the measured position of the inverted dummy's head.

GM, DaimlerChrysler, Toyota, Ferrari and Porsche recommended that if the agency establishes a headroom reduction criterion, it consider using a headform position procedure (HPF) that essentially represents a headform secured to an adjustable vertical support that is rigidly attached to the floor pan of the tested vehicle at the seat anchorages.

A number of these commenters also suggested that the agency consider removing any roof trim components (i.e., all headliner, trim, deployable countermeasures and grab handles) prior to testing. Further, these commenters also recommended that

¹⁹ Strashny, Alexander, "The Role of Vertical Roof Intrusion and Post-Crash Headroom in Predicting Roof Contact Injuries to the Head, Neck, or Face during FMVSS 216 Rollovers."

²⁰ FMVSS 201U, refers to those aspects of FMVSS No. 201 pertaining to the upper interior trim head protection requirements.

head contact with the roof structure itself be the only assessment criteria for compliance certification. GM recommended that manufacturers provide the headform location to NHTSA prior to a compliance test based upon the nominal design seating positions. Toyota, by contrast, recommended the agency determine the location for the 50th percentile male head position with the Head Restraint Measuring Device (HRMD)²¹ after first determining the H-point using the SAE J826 procedure, and then position the headform in the vehicle.

DaimlerChrysler recommended verifying compliance by a 200 N (44 pounds) resultant contact force in the upper neck load cell of a 50th percentile adult male Hybrid III head fixture at the location specified in the NPRM. DaimlerChrysler recommended that in the event the platen does not stop quickly enough after the resultant neck force reaches 200 N (44 pounds); the head fixture should be designed to either withdraw or become compliant by using a force limiting device in order to prevent any damage to the load cell in the dummy's head. GM also recommended a similar approach and suggested the agency consider a range of loads on the headform of 100 N (22 pounds) to 400 N (88 pounds).

Advocates recommended a maximum intrusion limit of no more than 76.2 mm (3 inches) in order to protect occupants taller than the 50th percentile male. Public Citizen recommended that NHTSA require that vehicle roof structures resist more than 76.2 mm (3 inches) of roof crush, and maintain the minimum amount of headroom proposed in the NPRM in order to reduce side window breakage and prevent B-pillar deformation, which it believes can alter seat belt geometry.

ARCCA, Mr. Slavik and the Advocates also recommended the agency use a 95th percentile adult male dummy instead of the smaller 50th percentile male to increase the stringency of the standard and further limit intrusion.

Testing with HPF: As noted above, the agency indicated in the SNPRM that it was considering whether to specify a test using a HPF in the final rule. We received a number of comments concerning this issue.

The Alliance reiterated its recommendation that NHTSA maintain the use of the 127 mm (5 inch) platen travel criterion. That organization stated that it does not support a “no head

contact” criterion, whether it is determined by use of a test dummy or via the use of an HPF with an associated contact force. The Alliance stated that the platen travel requirement would yield essentially the same roof strength and avoid unnecessary test-to-test variability and testing complexity. That organization stated that if the agency adopts a head contact criterion in the final rule, it is essential that the head contact device be a headform on a stand located at a position specified by the manufacturer and not a crash test dummy or a headform located based on what it claimed would be very unreliable and unrepeatable location data estimated from a test dummy or SAE J826 manikin (OSCAR) location. The Alliance stated that possible use of a 222 N (50 pound) contact criterion has not been supported by any scientific data.

In commenting on the SNPRM, GM stated that use of the 127 mm (5 inch) platen travel criterion rather than either a dummy or head contact fixture is required to prevent unnecessary test variation and complication while maintaining a comparable level of stringency.

AIAM did not endorse the HPF approach but suggested that the fixture might be equipped to measure neck load, to exclude incidental contact with trim items.

Public Citizen stated that defining head contact with the HPF by using force-deflection criteria would result in a significant number of front seat occupants suffering head and neck injuries.

Agency Response

After carefully considering the comments, the agency has decided to adopt the proposed headroom requirement, but with a different test procedure. Instead of specifying a procedure using a seated Hybrid III adult male dummy, we are specifying use of a HPF that positions the headform at the location of a 50th percentile adult male. To help ensure objectivity and in light of concerns about incidental contact with trim, head contact is defined as occurring when a 222 N (50 pound) resultant load is measured by a load cell on the HPF. Finally, to better ensure safety, we are retaining the current 127 mm (5 inch) platen travel requirement as well as adopting a headroom requirement.

Primary Rationale: At the time of the NPRM, the agency estimated benefits based on post-crash headroom, the only basis for which a statistical relationship with injury reduction had been established. After the NPRM, with

additional years of data available, a statistically significant relationship between intrusion and injury for belted occupants was established.

NHTSA cited its new headroom and roof intrusion analysis²² in the SNPRM. The agency added two years of NASS-CDS data to each analysis and found a new, stronger negative correlation between post-crash headroom and maximum injury severity of head, neck or face from roof contact. Also, for the first time, the agency was able to find a statistically significant correlation between vertical roof intrusion and head, neck, or face injury from roof contact. Based upon this new analysis, we believe that maintaining headroom, as well as restricting the amount of intrusion (retaining the platen travel requirement) will yield benefits in rollover crashes. Therefore, we believe both criteria should be included in the final rule.

Commenters opposing adoption of a headroom requirement raised a number of concerns, including ones related to the test procedure, practicability concerns, and whether a headroom requirement would result in benefits beyond those of the platen travel requirement. The issues related to the test procedure and practicability concerns are addressed below.

As to the issue of additional benefits associated with the headroom criterion, we note that, based on our testing, in the vast majority of vehicles it is likely that the limit on platen travel will be encountered before the one on headroom reduction. For these vehicles, the new requirement will not pose any significant challenges for manufacturers, particularly in light of the changes we are making in the test procedure. However, as we also consider vehicles with less headroom and potential future vehicles, we believe there is a need to adopt a headroom reduction requirement to help ensure post-crash survival space.

In the NPRM, we raised a concern that for vehicles with greater than 127 mm (5 inches) of headroom, limiting platen travel to 127 mm (5 inches) may impose a needless burden on these vehicles. However, manufacturers generally supported retaining the platen travel limit, suggesting that the requirement is not burdensome. Moreover, as indicated above, we now have a new analysis showing a statistically significant relationship between intrusion and injury for belted occupants.

Basic Test Procedure for Measuring Head Contact: To help analyze comments raising repeatability concerns

²¹ HRMD means the SAE J826 three-dimensional manikin with a headform attached, representing the head position of a seated 50th percentile male, with sliding scale at the back of the head for the purpose of measuring head restraint backset.

²² *ibid*

with the Hybrid III dummy and identifying when head contact occurred, the agency conducted a series of tests using alternative approaches. In the first series of tests conducted at NHTSA's Vehicle Research and Test Center (VRTC), the agency used a head positioning fixture developed by GM (GM-HPF).²³ The GM-HPF is a headform secured to an adjustable vertical support that is rigidly attached to the floor pan at the seat anchorages. The GM-HPF rigidly holds a headform in the location of a normally-seated 50th percentile male head and measures the load on the headform from contact with the interior roof as it is crushed.

The headform consists of a skull, headskin, and 6-axis upper neck load cell from a 50th percentile male Hybrid-III dummy (Part 572, subpart E). This assembly is mounted to the end of a channeled square tube (upper post). A second, similar tube (lower post) is perpendicularly mounted to a rectangular aluminum mounting plate. The upper and lower posts attach to each other and are parallel. The upper post can slide along the lower post. This provides vertical adjustment of the headform once the fixture is mounted in the vehicle. The GM-HPF also includes four metal support straps that attach between the upper/lower post and the mounting plate, in a pyramid configuration. These straps provide rigidity to the fixture and are attached after final positioning of the headform.

In the testing conducted at VRTC,²⁴ the head position of a normally seated 50th percentile male Hybrid-III dummy was determined by placing the seat at the mid-track position and using the SAE J826 (OSCAR) device to locate the H-point. A 50th percentile male Hybrid-III dummy was then positioned per the FMVSS No. 208 seating procedure and the head location was documented using a 3-dimensional measurement device. The dummy and seat were then removed. The GM-HPF mounting plate was attached to the vehicle floor and the headform was then raised until its vertical position matched that determined from dummy placement.

After gaining experience with the GM-HPF, the agency developed its own, simpler HPF approach for evaluating post crash headroom. In doing so, the agency determined that it is not necessary to use a test device with the complexity of a headform based on the Hybrid III dummy head, given the nature of the performance criterion being measured. Earlier testing had

shown that the skin on the Hybrid III dummy's head added a level of testing complexity that was unnecessary to the goal of identifying when roof contact occurs at a point in space. Therefore, the agency developed a simpler HPF using an FMVSS No. 201 headform that is currently used for testing instrument panels and seat backs. (This headform is effectively a 16.5 cm (6.5 inch) diameter metallic hemisphere).

During roof crush test series conducted at General Testing Laboratories,²⁵ the HPF was developed by mounting the FMVSS No. 201 headform to a cantilevered levering arm which was then attached to a tri-pod. The levering arm was maintained in position by air pressure and designed to collapse after a 222 N (50 pound) load was applied. The purpose of the cantilever design was to allow some downward movement so as not to damage the device after head contact is reached. The HPF was positioned in the vehicle at the 50th percentile male head position using the FMVSS No. 214 seating procedure recently adopted (72 FR 51908) and modified to use the OSCAR with a Head Restraint Measuring Device attached for repeatable placement. The HPF tri-pod apparatus was then rigidly secured to the floor of the vehicle. The FMVSS No. 201 headform was mounted on a 3-axis dummy neck load cell, and all loads and moments were recorded. The roof was then crushed until the unmodified interior roof made contact with the HPF and the resultant load, as measured by the load cell, exceeded 222 N (50 pounds). During our evaluation we defined "head contact" as occurring when a 222 N (50 pound) load is applied to the sphere, in the belief that this load level would correspond to structural roof contact rather than interior trim components coming loose. This was consistent with comments from DaimlerChrysler and GM that used a force load approach as a reliable method of identifying head contact and removing the uncertainty of random interior trim contact.

Our test experience with the simpler HPF proved to be repeatable in the tests and easier than using the Hybrid III dummy itself during the test.

We believe specification of the HPF appropriately addresses commenters' concerns regarding variability with regard to locating the dummy's head. With the HPF rigidly fixed to the vehicle, we also believe this addresses the concerns of manufacturers, such as Porsche, which alter the attitude of the

vehicle with respect to the load press when conducting roof crush tests.

Because head contact is defined as a load on the headform, the test result is more objective/repeatable, and not sensitive to incidental contact with interior surfaces that may disengage during testing.

We disagree with comments from manufacturers that recommended the removal of the roof's interior trim prior to testing in order to simplify the procedure. The agency's headroom analysis established a correlation between injuries and head contact with a NASS-CDS roof component when the injury source was the A-Pillar, B-Pillar, front or rear header, roof rail or the roof itself. These interior surfaces are considered interior trim. We believe they should be factored in when considering the available headroom in the test. By defining head contact as occurring when a 222 N (50 pound) load is applied to the headform, we are addressing concerns about incidental contact with trim. This definition of head contact also addresses concerns about possible conflicts with the intent of FMVSS No. 201U, with respect to concerns with incidental contact. If the headform experiences a 222 N (50 pound) load, the contact is not incidental and there is a safety issue related to available headroom.

We also disagree with comments from manufacturers recommending that the head contact device be a headform on a stand located at a position specified by the manufacturer and not a crash test dummy or a headform located based on SAE J826 manikin (OSCAR) location. The HPF test procedure (as would a test procedure using a test dummy) measures head contact in the vehicle being tested. However, the approach of using a headform on a stand located at a position specified by the manufacturer would not necessarily represent the actual vehicle build.

We note that the SAE J826 mannequin has long been incorporated in NHTSA's safety standards for purposes of determining the H-point location. Issues concerning the accuracy of measurements using this device and the HRMD were addressed at length in our rulemaking upgrading our head restraints standard. Manufacturers can address concerns about different trim and seating options by factoring in the location where the headform (and also the head of a typical average size male occupant) will be under those different options.

Definition of head contact:

As noted above, the Alliance stated that possible use of a 222 N (50 pound) contact criterion has not been supported

²³ See Docket Number NHTSA-2005-22143-195

²⁴ See docket entry NHTSA 2008-0015-003 for the vehicles tested with the GM-HPF.

²⁵ See report *Two-Sided Roof Crush Testing Analysis* placed in the docket with this notice.

by any scientific data. Public Citizen expressed concern that defining head contact with the HPF by means of force-deflection criteria would result in a significant number of front seat occupants suffering head and neck injuries.

We note that the load as defined is not intended to be an injury criterion, for which one would expect supporting scientific data, but is instead simply an objective way of defining head contact and avoiding treating incidental contact with loose trim as head contact. Our testing has shown, on average, once physical contact between the interior roof trim and the headform occurred resulting in the onset of a load on the headform, the platen traveled 6 mm (0.24 inches) prior to the load reaching 220 N (50 pounds). Therefore, we do not expect increased head and neck injuries from this approach. Moreover, retention of the current platen travel requirement will also prevent such increased injuries. We selected the 222 N (50 pound) contact criterion based on comments from GM and DaimlerChrysler and our own testing experience.

Possible Reduced Stringency:

IIHS, LSMM and Public Citizen expressed concern that if the platen travel requirement were not retained in addition to adopting the headroom criterion, adoption of the proposed headroom criterion would represent a decrease in stringency for the standard's performance criterion. This is not an issue since we are retaining the platen travel requirement.

Possible more restrictive requirements. We disagree with commenters which recommended that the agency reduce the platen travel requirement to 76.3 mm (3 inches).

On average, the vehicles the agency has tested have reached the maximum SWR in 90 mm (3.5 inches) of platen travel. A requirement for reduced platen travel would represent an increase in stringency and, in many respects, would be similar to a requirement for a higher SWR. We note that the agency has already been considering the possibility of a higher SWR, as well as two-sided test requirement, which would also increase stringency. We have not conducted testing to analyze the appropriateness of applying a 3 inch platen travel requirement to all vehicles. However, we believe the other issues we have considered ensure an appropriate level of stringency.

We also do not agree with commenters recommending the use of the 95th percentile dummy (or equivalent HPF) for measuring head contact. Restricting headroom to a 95th

percentile occupant is similar to limiting the platen displacement to 76.3 mm (3 inches) in increasing stringency. As indicated above, we believe the other issues we have considered ensure an appropriate level of stringency. Moreover, we believe that the relationship between vehicle headroom and occupant size is insignificant in most cases. It is likely that taller front seat occupants adjust the seat positions to prevent uncomfortable proximity to the roof such as by lowering the seat cushion bottom, increasing the seat back angle and/or adjusting the seat position further rearward.

Low roofline vehicles: In the NPRM, we discussed possible concerns with vehicles that have relatively little available headroom when the 50th percentile adult male dummy is positioned properly in the seat. Vehicles with these aerodynamically sloped roofs will hereafter be referred as "low roofline vehicles." We stated that we were concerned that, in some limited circumstances, the headroom between the head of a 50th percentile male dummy and the interior headliner is so small that even minimal deformation resulting from the application of the required force would lead to test failure. NHTSA requested comments on whether any additional or substitute requirements would be appropriate for low roofline vehicles in order to make the standard practicable.

Several commenters, including DaimlerChrysler, Ford, Porsche, Mitsubishi Motors R&D of America, Inc. (Mitsubishi) and Hyundai America Technical Center, Inc. (Hyundai), provided comments on low roofline vehicles. The commenters recommended that the requirements be limited to 127 mm (5 inches) of deflection for a load of 2.5 SWR in order to minimize the negative impact on continued availability of this type of vehicle if the agency were to adopt a headroom requirement. DaimlerChrysler stated that the proposed standard was not reasonable, practicable and appropriate for these types of motor vehicles as required by the Motor Vehicle Safety Act. It further stated that the agency had not demonstrated in the NPRM or the PRIA, the feasibility of going beyond 1.5 times the UVW in roof strength without head contact for vehicles with steeply raked windshields and reduced headroom.

DaimlerChrysler suggested its recommendation would be applicable to the Chrysler Crossfire, Dodge Viper, and McLaren Mercedes models and successors, which are generally designed with a steeply raked windshield and a low roofline for

reduced frontal area and low drag. It further stated that this modified requirement should also apply to other kinds of vehicles, such as any two-seater that is designed with a more aggressively raked windshield. DaimlerChrysler recommended that vehicles of this type could be identified or defined based on a set of characteristics such as the Static Stability Factor (SSF) (e.g., ≥ 1.4), NCAP rollover rating (e.g., ≥ 4 stars), height-to-width ratio (e.g., ≤ 0.75), windshield rake angle, vehicle height, etc.

Ford stated that low roofline vehicles are not the only vehicles that have problems with limited headform clearance. It stated that vehicles that may be considered as "high roofline" can also have limited headform-to-roof clearance due to interior package design. Based on the interior package design of a particular vehicle, regardless of roof line characteristics, the critical dimension (distance between the outboard side of dummy's headform and the roof side rail trim) can be minimal. Mitsubishi commented that headform-to-roof clearance is a concern for not only low roofline vehicles but may be more generically classified as being an issue for limited headroom vehicles.

Porsche expressed concern that low roofline vehicles have less opportunity for enhanced roof structures because the focus on performance and aerodynamics virtually eliminates the option of taller pillar supports.

Hyundai stated it will be challenging for low roofline vehicles and particularly two door coupe vehicles to meet the upgraded standard because of the lack of headroom and the possibility the B-pillar may not be loaded because it is further away from the A-pillar compared to a sedan. It requested that the agency define a low roofline vehicle to explicitly include two-door coupe vehicles in the definition. It also requested that these types of vehicles be allowed to meet the current requirements until it can be demonstrated that practicability with the upgrade is feasible.

Based on its analysis, the agency believes the requirements it is adopting will not create new problems for low roofline vehicles. In our most recent two-sided research program, the agency tested a 2006 Chrysler Crossfire, a vehicle identified as a low roofline vehicle. During the first-side test, the vehicle had a peak SWR of 2.9 at 97 mm (3.85 inches) of platen displacement. Head contact based upon our criteria (222 N load on the headform) occurred at 107 mm (4.21 inches) of platen travel. This showed the maximum SWR was reached prior to head contact. On the

second side, the Crossfire reached a 2.7 SWR prior to head contact at 135 mm (5.31 inches) of platen travel.

The agency tested another low roofline vehicle, the 2007 Scion tC. This vehicle achieved a maximum SWR of 4.6 on the first side at 113.3 mm (4.46 inches) of platen travel. Head contact occurred at 119 mm (4.68 inches) of platen travel. On the second side, the Scion achieved a 4.1 SWR prior to head contact at 95.0 mm (3.74 inches) of platen travel. From these tests we believe it is feasible and practicable for smaller vehicles with less initial headroom to meet the requirements. Since both are two-door vehicles, we disagree with Hyundai's assertion that two-door vehicles pose an unreasonable challenge.

We agree with Ford's observations that some vehicles that may appear to be "high roofline" vehicles, but may experience head contact in less platen travel than a "low roofline" vehicle. The 2007 Buick Lucerne, a large full size vehicle reached a maximum SWR of 2.3 at a platen displacement of 110 mm (4.33 inches). The vehicle did not reach the proposed SWR of 2.5. In this test, platen travel at head contact was less than the Crossfire. Therefore, the arguments being made for excluding low roofline vehicles may not be unique to low roofline vehicles. Ford's comments also illustrate the difficulty in identifying what is or is not a low roofline vehicle.

DaimlerChrysler suggested SSF or other vehicle parameters could be used to define low roofline vehicles and exclude them from the headroom requirement. However, we believe that this exclusion is not warranted based on our testing. Moreover, we are concerned about the safety impact of unnecessarily excluding vehicles from the upgraded requirements.

6. Leadtime and Phase-In

NHTSA proposed that manufacturers be required to comply with the new requirements three years after the issuance of the final rule. At that time, based upon vehicle testing, we estimated that 68 percent of the current fleet already complied with the proposed roof strength criteria. We anticipated the proposal would not require fleet-wide roof structural changes and believed the manufacturers had engineering and manufacturing resources to meet the new requirements within that timeframe.

In commenting on the NPRM, vehicle manufacturers and their associations argued that additional leadtime was needed, and that a significantly greater portion of the fleet would require

redesign than estimated by the agency. The Alliance, Ford and GM stated that approximately 60 percent of their fleets would need to be redesigned, and Hyundai commented that 75 percent of its vehicles would need changes to comply with the requirements.

Toyota, Ford, GM, Hyundai, Nissan and DaimlerChrysler stated that the agency underestimated the necessary modifications to vehicle design and manufacturing challenges that must be overcome to comply with the proposal. Ford, GM, DaimlerChrysler, and Toyota stated that the challenges are especially true for heavier vehicle over 2,722 kg (6,000 pounds) GVWR which have not been required to meet FMVSS No. 216.

GM and Ford stated that they rely on outside suppliers for advanced high strength material and currently there is an insufficient supply base for high strength steel. They also cited significant manufacturing challenges that must be overcome to adapt ultra high strength steel to the mass production environment. They argued that leadtime with a phase-in is necessary to permit growth in the supply base and allow the manufacturers to resolve manufacturability issues for high volume production requirements.

The vehicle manufacturers generally requested a 3-year leadtime followed by a multi-year phase-in. Most supported a minimum 3-year phase-in. GM requested a 4-year phase-in period, and DaimlerChrysler requested a 5-year phase-in only for vehicles over 3,855 kg (8,500 pounds). The AIAM requested compliance credits for an early phase in, while the Alliance, Ford and Mitsubishi requested carryforward credits. The AIAM and Ferrari requested that small volume manufacturers be permitted to comply at the end of the phase-in due to compliance difficulties, long product cycles and cost penalties associated with running structural changes to vehicle programs.

In commenting on the SNPRM, the Alliance reiterated points made in its comment on the NPRM, stating that the final rule needs to provide at least three years initial leadtime followed by a multi-year phase-in with carryforward credits. It stated that additional time is needed if the agency adopted the proposed head contact criterion, a two-side test requirement, or an SWR higher than 2.5. Ford suggested that if the agency adopted a more stringent requirement than the one it focused on in the NPRM, that vehicles meeting a 2.5 SWR/one-sided test requirement earn compliance credits before and during the phase-in.

Agency Decision/Response

After carefully considering the comments and available information, and for the reasons discussed below, we have decided to adopt different implementation schedules for vehicles with a GVWR of 2,722 kilograms (6,000 pounds) or less, i.e., the vehicles currently covered by FMVSS No. 216, and those with a higher GVWR. The implementation schedules we are adopting are as follows:

Passenger cars, multipurpose passenger vehicles, trucks and buses with a GVWR of 2,722 kilograms (6,000 pounds) or less. We are adopting a phase-in of the upgraded roof crush resistance requirements for these vehicles. The phase-in requirement for manufacturers of these vehicles (with certain exceptions) is as follows:

- 25 percent of the vehicles manufactured during the period from September 1, 2012 to August 31, 2013;
- 50 percent of the vehicles manufactured during the period from September 1, 2013 to August 31, 2014;
- 75 percent of the vehicles manufactured during the period from September 1, 2014 to August 31, 2015;
- 100 percent of light vehicles manufactured on or after September 1, 2015.

Credits may be earned during the phase-in, i.e., beginning September 1, 2012, and carried forward through August 31, 2015.

Small volume manufacturers are not subject to the phase-in but must meet the requirements beginning on September 1, 2015. Vehicles produced in more than one stage and altered vehicles must meet the upgraded requirements beginning September 1, 2016.

Multipurpose passenger vehicles, trucks and buses with a GVWR greater than 2,722 kilograms (6,000 pounds) and less than or equal to 4,536 kilograms (10,000 pounds). All of these vehicles must meet the requirements beginning September 1, 2016,²⁶ with the following exceptions. Vehicles produced in more than one stage and altered vehicles must meet the requirements beginning September 1, 2017.

Our rationale for this implementation schedule is as follows.

As discussed in the FRIA, a significantly larger proportion of the vehicle fleet will require changes than estimated at the time of the NPRM. This

²⁶ If heavier vehicles are designed to meet the new requirements early, their production volumes are not to be included when calculating the light vehicle fleet phase-in percent compliance. The phase-in schedule for the two fleets are separate.

would be true even for a 2.5 SWR/one-sided test requirement, and the proportion is higher for the 3.0 SWR/two-sided requirement. We therefore agree that a combination of approximately three years leadtime plus a multi-year phase-in is appropriate.

In developing the implementation schedule, we have considered costs and benefits. The vast majority of the benefits of the rule come from vehicles with a GVWR of 2,722 kilograms (6,000 pounds) and less. Of the 135 fatalities that will be prevented each year, 133 will come from these lighter vehicles. Moreover, the lighter vehicles are generally redesigned more often than the heavier vehicles. Also, manufacturers are familiar with designing and testing the lighter vehicles to meet the current FMVSS No. 216 requirements.

In order to implement the upgraded requirements in a cost effective manner, we believe it is appropriate to provide approximately three years of leadtime coupled with a 25 percent/50 percent/75 percent/100 percent phase-in for the lighter vehicles, and longer leadtime for the heavier vehicles. The benefits for the heavier vehicles are relatively small, and approximately seven years leadtime will generally permit manufacturers to improve roof strength at the same time they redesign these vehicles for other purposes.

While vehicle manufacturers made varying recommendations for the specific provisions of a phase-in, the phase-in we are adopting for lighter vehicles is within the general range of those recommendations. We recognize that manufacturers argued that longer leadtime should be provided for requirements more stringent than a 2.5 SWR/one-sided test requirement. However, while the 3.0 SWR/two-sided test requirement will increase the number of vehicles requiring redesign and the specific countermeasures that are needed, we believe that approximately three years of leadtime coupled with a 25 percent/50 percent/75 percent/100 percent phase-in provides sufficient time for manufacturers to make these changes. We note that the vehicles likely to present the greatest design challenges under our proposal were the ones with a GVWR above 2,722 kilograms (6,000 pounds), for which we are providing longer leadtime and a lower SWR requirement. Vehicle manufacturers have not provided persuasive evidence that longer leadtime is needed, or that a less stringent requirement should be established for an initial period.

We believe that providing for carry forward credits during the phase-in, but

not the earning of advance credits prior to the beginning of the phase-in, balances encouraging early compliance and manufacturer flexibility with also encouraging manufacturers to continue to improve roof strength during the years of the phase-in.

As with a number of other rulemakings, we are establishing special requirements for small volume manufacturers and for vehicles produced in more than one stage and altered vehicles.

Given the leadtime needed for manufacturers to redesign their vehicles to meet the upgraded roof crush requirements, we find good cause for the compliance dates included in this document.

b. Aspects of the Test Procedure

1. Tie-down Procedure

In the NPRM, we proposed to revise the vehicle tie-down procedure in order to improve test repeatability. Specifically, we proposed to specify that the vehicle be secured with four vertical supports welded or fixed to both the vehicle and the test fixture. If the vehicle support locations are not metallic, a suitable epoxy or an adhesive could be used in place of welding. Under the proposal, the vertical supports would be located at the manufacturers' designated jack points. If the jack points were not sufficiently defined, the vertical supports would be located between the front and rear axles on the vehicle body or frame such that the distance between the fore and aft locations was maximized. If the jack points were located on the axles or suspension members, the vertical stands would be located between the front and rear axles on the vehicle body or frame such that the distance between the fore and aft locations was maximized. All non-rigid body mounts would be made rigid to prevent motion of the vehicle body relative to the vehicle frame.

We explained that we believed this method of securing the vehicle would increase test repeatability. Welding the support stands to the vehicle would reduce testing complexity and variability of results associated with the use of chains and jackstands. We also stated that we believed that using the jacking point for vertical support attachment is appropriate because the jacking points are designed to accommodate attachments and withstand certain loads without damaging the vehicle.

Comments

Commenters on the proposed tie-down procedure included the Alliance,

DaimlerChrysler, Ford, GM, Toyota, AIAM, Mr. Chu, Hyundai and BMW Group (BMW). A number of commenters agreed with the agency's intention to revise the tie-down procedure for the quasi-static test to improve test repeatability. However, manufacturers raised specific concerns about the proposed procedure. AIAM, Mr. Chu, Hyundai and BMW alternatively recommended retention of the current tie-down procedure. Advocates and SAFE supported the revised tie-down procedure because it has the potential to ensure less vehicle movement during testing.

Ford suggested that the proposed tie-down procedure can cause localized, unrealistic floor pan deformations that can reduce the measured strength of the roof. The Alliance, DaimlerChrysler, Ford, GM and Toyota recommended providing one vehicle support per vehicle pillar. However, they recommended placing the support along the sill, as opposed to the jack points, since they stated that jack points are not designed to withstand the forces generated during a roof crush test. The commenters suggested that this would minimize unwanted body displacement by providing a direct load path during testing which the proposal does not address. For body-on-frame vehicles, DaimlerChrysler also recommended support of the vehicle frame, in addition to the pillar supports, to further prevent sag of the body. In the event that the agency adopts the practice of supporting the body at the pillars, the Alliance, GM, and BMW also requested that a minimum area of support be provided to avoid concentrated loading.

The Alliance, BMW and Ford also had concerns about welding supports to the vehicle body. The commenters stated that welding could decrease the material properties of the body reducing the measured roof strength, and welding might not be practical or possible for non-ferrous or composite materials. BMW alternatively recommended clamping instead of welding, citing concerns about welding certain materials and the possibility of failure of the sills due to the welding. Ford recommended contacting the manufacturer for instructions about welding aluminum sills, if the agency proceeded with the welding protocol.

AIAM, Mr. Chu, Hyundai and Nissan recommended maintaining the existing procedure that supports the entire length of the sill in order to reduce complexities and unwanted body deformation with the tie-down proposal. Nissan suggested supporting the wheelbase at the sill flange pinch welds between the two channels that grab the

pinch weld on the bottom of the sill. The side sill flange would be constrained to prevent transverse body movement when tested. Hyundai recommended that the current procedure be permitted at the manufacturer's option since it believes the revised tie down procedure is burdensome. DaimlerChrysler and Toyota also recommended continuous mounting along the sills suggesting this would prevent unwanted body deformation at the jack point locations.

For vehicles without B-pillars, the Alliance, Ford, and GM recommended that a support be placed at the seam between the doors as if a pillar existed between the doors. The Alliance stated that doors connected without a pillar often have reinforcements to compensate for the structure that would be afforded by a pillar if it were part of the vehicle design, and therefore, the joint between the doors will act as one of the direct load paths from the roof to the rocker. Without a support at the door joint, the Alliance suggested that the roof strength cannot be accurately measured in these types of vehicles.

Agency Response

As part of analyzing the comments on the proposed tie-down procedure for the quasi-static test, the agency conducted analytical simulations using a finite element model on a late model Ford Explorer.²⁷ First the agency performed an analysis of the proposed procedure where the vehicle was supported at the jack locations. Two additional models were also developed to evaluate supporting the vehicle body under the pillars and continuously along the length of the body sill, as the commenters suggested.

The Ford Explorer was modeled because it is a body-on-frame²⁸ vehicle, and according to the comments, the proposed procedure would not accurately evaluate the roof strength of that type of vehicle. The first Explorer tie-down model followed the NPRM procedure where the vehicle was supported at its jack point locations. This was along the frame mounted inward of the vehicle body sill in the case of the Explorer. The analysis showed that the NPRM procedure produced compression of the body-to-frame rubber body mounts. We believe this tie-down simulation did not

accurately evaluate the strength of the roof because the body was not isolated in the simulation. The loading of the body mounts is also unrealistic in a rollover. The results were consistent with Ford's comment that suggested supporting a vehicle by its frame at the body mount locations could cause floor pan deformation and thereby reduce the measured strength of the roof.

The results of the other simulations (vehicle secured under the pillars and vehicle secured along the rocker/sill) showed higher roof strength than the NPRM procedure. There was nearly a 7 percent increase in roof strength within 127 mm (5 inches) of platen travel when the vehicle's body was supported under the pillars compared to the NPRM procedure. The simulation results using the continuous sill support tie-down showed a 3 percent increase in roof strength compared to the NPRM procedure. Overall, in both simulations, the body sag in the floor pan did not appear to be a concern and produced a more realistic loading of the roof. The load-deformations curves were also similar, whereas the results from the simulation using the NPRM tie-down procedure diverged early in the analysis at approximately 18,000 N or 0.8 SWR.

We note that the full sill tie-down procedure generated a lower peak force when compared to the vehicle supported under the pillars. The simulation for the full sill tie-down procedure did not include any constraints for the Explorer's frame. However, when the vehicle body was supported under each pillar, a number of vertical supports were added to support the mass of the frame. This could explain the slight difference in the maximum strength of the roof. However, we believe the difference is negligible.

After considering the comments and the computer simulations, we decided, for purposes of fleet testing, to revise the tie-down procedure to support the vehicle continuously under the sill. We believe this approach further reduces any variability compared to the Alliance recommendation because the entire wheelbase of the vehicle is supported and not just under each pillar. Also, the peak force difference in the computer models was not a significant issue because both methods addressed the commenters' main concern of inappropriate floor pan deformation. For body-on-frame vehicles, additional supports would be placed under the frame as this constraint was not included in the computer simulation and might account for the difference in peak force. The full sill tie-down procedure is consistent with the existing

FMVSS No. 216 requirement supported by AIAM, Mr. Chu, Hyundai, and Nissan.

For the fleet testing,²⁹ the vehicle's sill at the body flange weld was fully supported along the wheelbase between two box tubes and securely fixed into place with high strength epoxy. For body-on-frame vehicles, additional supports were placed under the frame to reduce body sag created by an unsupported frame, as recommended by DaimlerChrysler. Epoxy was selected in response to the Alliance, BMW and Ford's comments that welding may adversely alter the vehicle's structure prior to testing. We believe the epoxy will not alter the material properties of the vehicle structure or cause complications for sills made of non-ferrous or composite materials. The revised test procedure provided support for each of the vehicle pillars and provided a stable load path when tested, consistent with the recommendations by the Alliance, DaimlerChrysler, Ford, GM and Toyota. Also, by supporting the vehicle along the wheelbase, which includes the door seam for vehicles without a B-pillar (the joint between the doors), a reactionary surface is provided for the applied load when tested, addressing the Alliance, GM and Ford's concerns.

During our evaluation of the tie-down procedure,³⁰ dial indicators were placed at the sill below the vehicle's pillars on the opposite side of the platen travel to check for vehicle displacement during the test. The tie-down procedure showed on average less than a millimeter (0.04 inches) of body displacement at all measurement locations, parallel to the direction of platen motion for both unibody and body-on-frame vehicles. For comparison, the agency also tested a Buick Lacrosse that was rigidly supported along the entire wheelbase and compared the result to another Lacrosse test where the sill was supported along the wheelbase only at 152.4 mm (6 inch) increments. The Lacrosse was also supported under the pillars, as recommended by the

²⁹ See report, *Two-Sided Roof Crush Strength Analysis*, placed in the docket of this notice.

³⁰ The agency measured the sill displacement at three locations along the wheelbase on the side opposite to the force application on the roof, for 13 vehicles. Ten of the tests were single-sided and three were two-sided. The sill displacement ranged from 0 to 2.3 mm (0.09 inches). The VW Jetta achieved the highest SWR level at 5.7 in this data set and experienced almost no sill movement. In the three two-sided tests in this series, conducted with the Subaru Tribeca and two Buick Lacrosses, the agency did not observe any significant difference in sill displacement on the second side compared to the first.

²⁷ See report, *Finite Element Simulation of FMVSS No. 216 Test Procedures*, placed in the docket with this notice.

²⁸ A body-on-frame vehicle is constructed by attaching a vehicle body to a rigid frame which supports the drivetrain. At the attachment points, rubber body mounts are used to isolate the body from vibration.

Alliance. The results showed that the body displacement was lower for the full sill tie-down when compared to the results where the sill was only partially supported.

After considering the comments and in light of the testing and simulations, we are adopting the revised tie-down procedure, where the vehicle is supported at the sill, along the entire wheelbase. This procedure reduces vehicle displacement, more accurately measures the strength of the roof, and is more robust than the procedure recommended by the Alliance and its members. Furthermore, the revised test procedure addresses the comments to the NPRM because it supports the vehicle pillars during testing and reduces the likelihood of vertical and horizontal translation of the body.

We note that, in light of the fact that the test procedure is consistent with the current FMVSS No. 216 test procedure while providing improved clarity, the agency has adopted it for use in current FMVSS No. 216³¹ compliance tests. This procedure has been used for 19 fiscal year 2007 and 2008 OVSC compliance tests.

2. Platen Angle and Size

In the NPRM, we did not propose to change the test device orientation or the size of the test plate. However, we included a discussion of comments related to test device orientation and size that we had received in response to the October 2001 RFC.

Under the current test procedure specified in FMVSS No. 216, the test plate is tilted forward at a 5-degree pitch angle, along its longitudinal axis, and rotated outward at a 25-degree angle, along its lateral axis, so that the plate's outboard side is lower than its inboard side. The test plate size of 762 mm (30 inches) wide by 1,829 mm (72 inches) long is designed to load the roof over the occupant compartment. The edges of the test plate are positioned based on fixed points on the vehicle's roof. The forward edge of the plate is positioned 254 mm (10 inches) forward of the forwardmost point on the roof, including the windshield trim. We note that, as discussed later in this document, there is a secondary test procedure for certain vehicles with raised roofs or altered roofs, which we proposed to eliminate.

Comments

The agency received numerous comments and recommendations to change the platen test angle and size. A

number of the comments were from safety advocacy groups. Some commenters recommending a 2-sided test requirement recommended that we use different criteria for the two tests.

Consumers Union cited comments it had made on the agency's 2001 RFC and the agency's discussion in the NPRM. That commenter noted that it had recommended that the agency modify the test plate load and size. It stated that it continues to believe that the current plate load and size does not reflect real-world rollover conditions. Consumers Union stated that it believes that more of the roof crush force is absorbed by the A-pillar than accounted for by the current or proposed procedure. It recommended that the agency conduct additional studies concerning this issue.

IIHS commented that testing roof crush strength at multiple load angles would add to the meaningfulness of the quasi-static test requirement that NHTSA currently specifies. However, it also stated that in the absence of a range of plate angles, any distinct test angle choice should be supported by evidence that such an angle is representative of a significant percentage of real-world rollovers.

Various commenters recommended that the agency change the platen pitch in ways they believe would better reflect the more aggressive loading angles that are frequently sustained in real-world rollover crashes, particularly for SUVs and pickups. The general recommendation was to increase the pitch angle of the platen to 10 degrees because commenters believed the proposed 5 degree pitch is not realistic.

CAS stated that the pitch angle must be increased to at least 10 degrees to emulate actual rollovers where damage to front fenders is testimony to the fact that in a rollover, the pitch angles are this high. Advocates suggested that vehicles be evaluated at different platen angles, up to and including 10 degrees pitch \times 45 degrees roll.

Mr. Chu suggested a series of procedures he believed would best address the plate angle issue. His 6-step procedure would test each front corner of the roof three times, with the roll angle of the plate maintained at 25 degrees, and the pitch angle from 5 to 10 degrees.

Consumers Union and Mr. Friedman encouraged the agency to consider the use of a smaller platen in order to load the A-Pillar and not extensively load the B-pillar. Mr. Friedman submitted two-sided test data published in a recent technical publication using a smaller platen 301 mm (11.8 inches) wide by 610 mm (24 inches) long and at different

pitch and roll angles.³² The commenter stated that the smaller plate more aggressively loads the A-pillar. It showed the roof achieved a lower SWR on the second side by as much as 40–70 percent compared to the current FMVSS No. 216 procedure.

Agency Response

After carefully considering the comments, we have decided to maintain the current platen size and the pitch and roll angle. We note that many of the issues raised by the commenters were ones that were also raised in comments on the 2001 RFC.

Prior to issuing the NPRM, the agency conducted a test series to evaluate alternative platen angles using the FMVSS No 216 platen.³³ A finite element study was first conducted to evaluate a range of platen configurations and to select appropriate conditions for testing. NHTSA tested four vehicle pairs using 5 degree \times 25 degree and 10 degree \times 45 degree platen angles. The peak SWR from these tests did not demonstrate a consistent pattern between the two test conditions. For two vehicle models, the 10 degree \times 45 degree tests generated a higher peak SWR, whereas, the 10 degree \times 45 degree tests generated a lower peak SWR in the others. Therefore, the test results were inconclusive.

To help evaluate the comments submitted in the NPRM docket, the agency extended the previous finite element studies to evaluate alternative platen angles in conjunction with a smaller platen.³⁴ The finite element model of a 1997 Dodge Caravan was used to evaluate two-sided simulations with a 5 degree \times 25 degree orientation on the first side and a 10 degree \times 45 degree orientation on the second side. The reduction in peak SWR for using a 10 degree \times 45 degree platen angle on a second side test was 18.7 percent. The 18 percent reduction in peak SWR, while significant, is much less than the 40 to 70 percent shown in the test results submitted to the docket. The results were also in line with our two-sided vehicle test results using the 5 degree \times 25 degree platen orientation for both sides. On average there was an 8.7 percent reduction of strength on the second side compared to the first. Furthermore, we found an average

³² Friedman D., et al., "Result From Two Sided Quasi-Static (M216) and Repeatable Dynamic Rollover Test (JRS) Relative to FMVSS 216 Tests," 20th ESV Conference, Lyon, France, 2007.

³³ See Docket NHTSA 2005–22143–57: Load Plate Angle Determination and Initial Fleet Evaluation.

³⁴ See, *Finite Element Simulation of FMVSS No. 216 Test Procedures*, placed in the docket with this notice.

³¹ TP–216–05 Laboratory Test Procedure for FMVSS No. 216, November 16, 2006.

difference of approximately 7.1 percent lower peak force for the second side in vehicles under 2,722 kilograms (6,000 pounds) GVWR and 14.9 percent lower peak force for the second side in vehicles over 2,722 kilograms (6,000 pounds) GVWR.

To evaluate how a smaller platen affects roof strength measurements, the agency also conducted simulations with a smaller 305 × 610 mm (12 × 24 inch) platen using a 10 degree × 45 degree platen angle on a Dodge Caravan model. The results showed an approximate six percent decrease in peak force compared to our baseline results with a larger platen using the same configuration. However, the simulations showed the potential for platen edge-to-roof contact. Since the platen-to-roof contact is intended to be a surrogate for vehicles rolling on the ground, localized loading from the platen edge can cause unrealistic loading conditions.

Therefore, the results demonstrated how a smaller platen localized the stress on the A-pillar, reducing the measured strength during the evaluation, but the crush deformation does not appear to represent real-world crash results.

Many of the commenters assumed that a higher pitch angle leads to a more demanding test procedure and also assumed it is more reflective of real world rollovers, particularly for pickups and SUVs. However, only limited anecdotal evidence (based on interpretation of crash photos) was provided to support these conclusions. Due to the extremely complex and chaotic nature of rollover crashes, it is impossible for any one test to fully replicate all of the loading forces that occur in all real-world crashes. However, we believe the platen size and pitch/roll angles proposed and currently incorporated in the standard produce roof crush damage patterns that are representative of the crash damage patterns observed in real-world crashes.³⁵ The use of the smaller platen would result in edge contact and unrealistic buckling of the roof. We did not propose to alter these parameters in the NPRM or SNPRM.

We are also not persuaded by commenters that recommended varying the pitch and roll angle in a two-sided test. As discussed above, the agency conducted analytical simulations varying the platen angles. Based on the similarity of the post test damage pattern in that research, there was not sufficient evidence to justify changing the load plate configuration from our

current protocol. We are further not persuaded by CFIR, Mr. Chu, and LSSM comments to require testing on both sides with a smaller platen size.

Analytical simulations³⁶ conducted by the agency using a Dodge Caravan showed that a smaller platen is sensitive to positioning and can result in edge contact. As a result, a smaller test plate can produce unrealistic contact with the roof and highly localized loading, inconsistent with real world rollover crashes. CFIR's finding of a 40–70 percent reduction in roof strength for the second side tests it conducted may be attributed to its smaller platen adding unrealistic stress on the roof.

3. Testing Without Windshields and/or Other Glazing in Place

We did not propose to change the current FMVSS No. 216 procedure and test the vehicle without the windshield or side windows in place. In the NPRM, we stated:

The agency believes that windshields provide some structural support to the roof even after the windshield breaks because the force-deflection plots in some of the recent test vehicles (e.g., Ford Explorer, Ford Mustang, Toyota Camry, Honda CRV) show little or no drop off in force level after the windshield integrity was compromised. Further examination of real-world crashes indicates that the windshield rarely separates from the vehicle, and therefore, does provide some crush resistance. Because NHTSA believes that the vehicle should be tested with all structural components that would be present in a real-world rollover crash, we decline to propose testing without the windshield or other glazing. 70 FR 49238.

A number of commenters, including ones from safety advocacy groups, questioned the contribution of the windshield to the overall strength of the roof and generally recommended the windshield be removed prior to the test. Advocates, Boyle, et al., CFIR, Consumers Union, DVExperts, IIHS, Public Citizens, Penn Engineering, and Perrone commented that windshields often break in a rollover, and stated that the agency should not specify a test procedure with windshields in place. Consumers Union expressed concern about aftermarket windshield installation and the unquantifiable strength of the windshield in a crash. The Engineering Institute (EI) and Mr. Hauschild recommended that if the agency maintains the 2.5 SWR requirement then the windshield should be removed. Mr. Slavik stated he conducted tests which confirm that on some vehicles, damage to the

windshield significantly reduces the force and energy required to produce an incremental amount of intrusion.

Technical Services recommended that the side window glass should be required to be preserved during testing to improve vehicle rollover performance. Xprts and Mr. Friedman also recommended that the side windows should not be permitted to fail during the test. Both commenters referenced Volvo's internal criteria and suggested that tempered glass windows can remain intact.

ARCCA, Consumer Union, Specialty Equipment Market Association (SEMA) and Hyundai raised concerns with regard to vehicles equipped with sunroofs. ARCCA and Consumers Union suggested vehicles equipped with sunroofs meet the roof crush requirements. Hyundai noted that vehicles equipped with sunroofs have reduced headroom compared with those without sunroofs. SEMA requested the agency ensure aftermarket sunroofs be permitted because they are installed inside the roof's perimeter cage.

Agency Response

After considering the comments, we decline to change the current test procedure in which the windshield and side windows remain in place during FMVSS No. 216 tests. We also disagree with the recommendation that the agency require side windows to be preserved during test. The agency was not presented with new information showing windshield breakage in a rollover significantly contributed to a reduction in roof strength.

We have examined the post crash windshield status for 1997–2006 NASS investigated rollover crashes with greater than one quarter turn. The majority of the windshields were coded as either “in place and cracked” or “in place and holed.” Less than 10 percent of weighted incidents indicate the windshield is “out of place.”

While Mr. Slavik stated he conducted testing, the agency was not provided data to evaluate. He asserted that there is anecdotal acknowledgement by some manufacturers that the windshield provides upwards of 30 percent of the measured roof strength. We note that that the agency's testing showed that windshield breakage has not been a factor in the maximum strength of the roof for some vehicles.³⁷ The peak load continued to increase after windshield breakage in the testing of the 2003 Ford Focus, 2003 Chevrolet Cavalier, and 2002 Nissan Xterra. In the case of the

³⁵ See Docket NHTSA 2005–22143–56: Roof Crush Analysis Using 1997–2001 NASS Case Review, 2004.

³⁶ See, *Finite Element Simulation of FMVSS No. 216 Test Procedures*, placed in the docket with this notice.

³⁷ See *NHTSA–2005–22143–0049: Roof Crush Research: Phase 3—Expanded Fleet Evaluation*.

Cavalier, the windshield did not contribute to a decrease in strength until 170 mm (6.7 inches) of platen travel.

The windshield is a structural element for some vehicles, and we continue to believe that vehicles should be tested with all structural components that would be present in a real-world rollover crash. We declined to propose testing without the windshield or other glazing for that reason, and we are not persuaded that there is sufficient justification to revise our position.

The agency also wanted to ascertain the influence of sunroofs on roof strength. The Scion tC, Cadillac SRX and Ford Edge were tested with large panoramic sunroofs. The glass panel sunroof in the Scion tC shattered during the two-sided test, yet the glass panel in the SRX did not fail during the single-sided only test. After review of the load-deformation curves for both vehicles, the test results showed the effect of the sunroof was insignificant to the overall strength of the roof. In the case of the Scion tC, at the point when the sunroof glass broke during the first side test, there was no change in the platen load. In the case of the Ford Edge, the rear glass panel of the sun roof failed in the second-sided test; however, the front glass panel over the front row occupants remained intact. This occurred well after 125 mm of platen travel. As a result, we believe it is practicable for vehicles with sunroofs (including large panoramic roofs) to meet the requirements and we do not foresee this upgrade inhibiting aftermarket sunroofs mounted within the roof structure.

In response to Consumers Union, the possibility exists that aftermarket windshield installations may not perform to OEM standards. However, we do not believe this possibility justifies changing roof strength requirements for all new vehicles.

Xprts and Mr. Friedman recommended a requirement that the side windows not break during the roof strength test. The agency investigated the contribution of side windows to the strength of the roof structure. Our testing showed that side window breakage is directly correlated to platen displacement with limited effect on the strength of the roof. In reviewing the load-deformation curves at the point where the side glass breaks, there is no measurable drop in load of the roof and it generally occurs well after the peak strength of the roof has been reached.³⁸ For completeness, the agency also assessed the impact of rear window breakage. The rear windows broke well after peak strength was reached and

generally past 127 mm (5 inches) of platen travel. The breakage of the rear window glass resulted in a slight drop in the strength of the roof particularly in pick-up trucks where the vertical glass is loaded by the test device and can add some strength. Overall, the impact of the side and rear glass had little impact on the strength of the roof. We also note that such a requirement is outside the scope of notice of the proposal.

4. Deletion of Secondary Plate Positioning Procedure

In the NPRM, we proposed to apply the primary plate procedure for all vehicles, removing the secondary plate procedure that applies to some raised and altered roof vehicles. We explained that the secondary plate positioning procedure produces rear edge plate loading onto the roof of some raised and altered roof vehicles that may cause excessive deformation uncharacteristic of real-world rollover crashes. Because an optimum plate position cannot be established for all roof shapes, the testing of some raised and altered roof vehicles will result in loading the roof rearward of the front seat area. We stated that we believe this is preferable to edge contact because edge contact produces localized concentrated forces upon the roof typically resulting in excessive shear deformation of a small region. We also stated that we believe that removing the secondary plate position would make the test more objective and practicable.

Advocates was the only commenter on this issue and opposed eliminating the secondary plate positioning. It stated that reverting back to the primary plate position for aerodynamic roof vehicles would induce unrealistic loads in that the proportion of force applied to the roof is excessively concentrated over the B-pillars. It stated that as a consequence, test conditions and roof response to plate loading can be substantially different than the loading that actually occurs in real-world rollovers of these vehicles where the A-pillars receive a proportionately greater force. Advocates suggested this is crucial because some vehicles with severely sloped A-pillars are candidates for A-pillar collapse in rollover crashes and the percentage of new vehicles with severely raked A-pillars and aerodynamically sloped roofs has increased each year since their use began in the early to mid-1990s.

Agency Response

After considering Advocates' comment, we have decided to remove the secondary plate procedure. We do not agree that the FMVSS No. 216 platen size and positioning produces

unrealistic loading of aerodynamic roofs. This issue was considered in the 1999 final rule (64 FR 22567) where the agency adopted a revised platen positioning procedure to reduce the likelihood of unrealistic loading on vehicles with rounded roofs. The agency's recent testing of modern vehicles has shown the current plate positioning procedure does distribute the load between the A- and B-pillars. Generally, the plate's initial point of contact with the roof is slightly behind the A-pillar including the Volvo XC90 which had a large amount of curvature to the roof in the test area compared to most vehicles tested.

However, we continue to believe that edge contact induced by the secondary plate procedure results in unrealistic loading specifically when the roof is raised or altered. In some circumstances, the plate will essentially punch through the sheetmetal instead of loading the roof structure. We also do not believe vehicles with steeply raked A-pillars are common architectures for raised and altered roof vehicles. Vans with more upright A-pillars are generally modified to have their roofs raised or altered. We are not aware of such changes to traditional passenger cars with steeply raked A-pillars.

5. Removal of Roof Components

FMVSS No. 216 currently specifies removal of roof racks prior to platen positioning or load application. We did not propose to change this provision.

Xprts recommended that the roof be tested as the vehicle is to be sold, with roof racks or other equipment in place. That commenters stated that removal of roof racks prior to conducting the roof crush test eliminates a typical roof failure mode. It states that roof rack mountings initiate buckling of the roof, increasing the risk of occupant injury from roof panel buckling.

After considering this comment, we decline to change the current test procedure. No data were provided by Xprts to support its contention that roof racks result in a typical roof failure mode and thereby increase the risk of occupant injury from roof panel buckling. We reviewed several NASS-CDS cases³⁹ of utility vehicles with roof racks that had undergone rollover crashes. Our review did not support the contention that the presence of a roof rack initiated buckling of the roof and increased the risk of occupant injury. There was also no general trend

³⁹ Photographs collected from NASS-CDS Case Query Page. NASS-CDS cases examined: 100121, 102005185, 146004985, 161005827, 656500082, 471300143, and 129005218.

³⁸ *Ibid.*

concerning injury severity and presence of a roof rack in the reviewed cases.

We further reviewed our fatal hardcopy case files⁴⁰ and could not identify a single case where the roof rack appeared to aggravate the deformation of the roof structure.

6. Tolerances

In response to comments from the Alliance and Chrysler LLC, we are adding several tolerances in the regulatory text to help improve test repeatability. We note that platen angles are measured from the horizontal and not from the vehicle's frame of reference. Measuring platen angles with respect to the ground is more objective than using the test vehicle's frame of reference because the latter would introduce manufacturing variability. We note that we are not including a specification concerning platen overshoot on the first side test since we will not conduct compliance tests beyond the specified SWR.

We decline to add a calibration procedure for the test device or to make changes relating to load application rate or to add platen material specifications. The basic FMVSS No. 216 test procedure has been used for many years, and the commenters did not provide persuasive evidence that changes are needed in these areas. As to platen materials, we believe the current specification for a rigid unyielding block is sufficient.

c. Requirements for Multi-Stage and Altered Vehicles

For vehicles manufactured in two or more stages,⁴¹ other than vehicles incorporating chassis-cabs,⁴² we proposed to give manufacturers the option of certifying to either the existing roof crush requirements of FMVSS No. 220, *School Bus Rollover Protection*, or the new roof crush requirements of FMVSS No. 216. FMVSS No. 220 uses a horizontal plate, instead of the angled plate of Standard No. 216.

As explained in the NPRM, multi-stage vehicles are aimed at a variety of niche markets, most of which are too small to be serviced economically by single stage manufacturers. Some multi-

stage vehicles are built from chassis-cabs that, by definition, have a completed occupant compartment. A chassis-cab's roof is an integral part of its body structure surrounding the seats for the occupants. Other vehicles are built using incomplete vehicles that do not have a completed occupant compartment. These include a van cutaway, which consists of the frame, drive train, steering, suspension, brakes, axles, and the front body section of a van that has no body structure behind the two front seats. Another example is a stripped chassis. A final stage manufacturer would typically complete the occupant compartments of these incomplete vehicles by adding body components to produce a truck (e.g., work truck) or multipurpose passenger vehicle (e.g., motor home).

In developing our proposal, we considered whether the proposed standard would be appropriate for the type of motor vehicle for which it would be prescribed. We stated that we believed it was appropriate to consider incomplete vehicles, other than those incorporating chassis-cabs, as a vehicle type subject to different regulatory requirements. We anticipated that final stage manufacturers using chassis cabs to produce multi-stage vehicles would be in position to take advantage of "pass-through certification" of chassis-cabs, and therefore did not believe the option of alternative compliance with FMVSS No. 220 was appropriate.

We noted that while we believed that the requirements in FMVSS No. 220 have been effective for school buses, we were concerned that they may not be as effective for other vehicle types. As noted above, the FMVSS No. 216 test procedure results in roof deformations that are consistent with the observed crush patterns in the real world for light vehicles. Because of this, we explained that our preference would be to use the FMVSS No. 216 test procedure for light vehicles. We believed, however, that this approach would fail to consider the practicability problems and special issues for multi-stage manufacturers.

We stated that in these circumstances, we believed that the requirements of FMVSS No. 220 appeared to offer a reasonable avenue to balance the desire to respond to the needs of multi-stage manufacturers and the need to increase safety in rollover crashes. Several states already require "para-transit" vans and other buses, which are typically manufactured in multiple stages, to comply with the roof crush requirements of FMVSS No. 220. These states include Pennsylvania, Minnesota, Wisconsin, Tennessee, Michigan, Utah, Alabama, and California. We tentatively

concluded that these state requirements show the burden on multi-stage manufacturers for evaluating roof strength in accordance with FMVSS No. 220 is not unreasonable, and applying FMVSS No. 220 to these vehicles would ensure that there are some requirements for roof crush protection where none currently exist.

Comments

We received comments concerning requirements for multi-stage and altered vehicles from Advocates, NTEA, NMEDA and RVIA.

Advocates stated that it opposes permitting FMVSS No. 220 as an alternative for multi-stage vehicles. It claimed that FMVSS No. 220 is a "weak" standard whose effects on roof strength in actual rollover crashes are mostly unknown.

NTEA recommended that all multi-stage vehicles be excluded from roof crush resistance requirements. It stated that manufacturers of non-chassis-cab vehicles will not be able to conduct the tests or perform engineering analysis to ensure conformance to FMVSS No. 220. NTEA also disagreed with the assumption that the presence of state requirements for FMVSS No. 220 compliance demonstrates that final stage manufacturers can actually comply. It stated that the ability of school bus and para-transit bus manufacturers to comply with FMVSS No. 220 does not reflect the ability of typical final stage manufacturers to comply with FMVSS No. 220.

NTEA also stated it is impractical for the agency to assume manufacturers of multi-stage vehicles built on chassis-cabs will be able to use pass-through certification for compliance. That organization stated that these type of vehicles are generally unique and built to customer specifications. It also raised a concern that some manufacturers of chassis-cabs may not provide the necessary specifications for the final stage manufacturer to rely on pass-through certification as it applies to roof strength. It argued that the final stage manufacturer would therefore be responsible for conducting costly analysis and testing to verify compliance with FMVSS No. 216.

NMEDA expressed concern that the FMVSS No. 220 option would only be available for multi-stage vehicles. It asked that the FMVSS No. 220 option be extended to raised or altered roof vehicles. To encompass the modifiers in the proposed upgrade to FMVSS No. 216, NMEDA asked that a vehicle roof that is altered after first retail sale be considered in compliance if it meets the requirements of FMVSS No. 216 or

⁴⁰ See Docket Number NHTSA 2005-22143-56: Roof Crush Analysis Using 1997-2001 NASS Case Review.

⁴¹ Vehicles manufactured in two or more stages are assembled by several independent entities with the "final stage" manufacturer in most cases assuming the ultimate responsibility for certifying the completed vehicle.

⁴² Under 49 CFR § 567.3, chassis-cab means an incomplete vehicle, with a completed occupant compartment, that requires only the addition of cargo-carrying, work-performing, or load-bearing components to perform its intended functions.

FMVSS No. 220. NMEDA also stated that raising a roof increases the available headroom and that the roof therefore can crush more before there is any contact with an occupant's head. NMEDA requested the agency account for the additional headroom beyond the original vehicle's headroom in establishing any requirement.

RVIA supported our proposal to permit FMVSS No. 220 as an option for small motor homes as this would allow manufacturers to address the unique issues concerning such specialized vehicles built in two or more stages.

Agency Response

After carefully considering the comments and as explained below, we are providing a FMVSS No. 220 option for multi-stage vehicles, except those built on chassis-cab incomplete vehicles, and for vehicles which are changed in certain ways to raise the height of the roof. For example, a van may be altered by replacing its roof with a taller structure (referred to as a raised roof) to better accommodate a person in a wheelchair. We are also excluding a narrow category of multi-stage vehicles from FMVSS No. 216 altogether, multi-stage trucks built on incomplete vehicles other than chassis cabs.

In discussing the issues raised by commenters, we begin by addressing the comment of Advocates. That organization opposed permitting FMVSS No. 220 as an alternative for multi-stage vehicles because it believes that FMVSS No. 220 is not sufficiently stringent and that its effects on actual rollover crashes are mostly unknown.

As we discussed in the NPRM, we believe the requirements in FMVSS No. 220 have been effective for school buses, but we are concerned that they may not be as effective for other vehicle types. We explained that our preference would be to use the FMVSS No. 216 test procedure for light vehicles, but that this approach would fail to consider the practicability problems and special issues for multi-stage manufacturers.

Advocates did not provide analysis or data addressing the special circumstances faced by multi-stage manufacturers, or explain why it believes these manufacturers can certify compliance of their vehicles to FMVSS No. 216. Therefore, that commenter has not provided a basis for us to take a different position than we took in the NPRM.

We next turn to the issues raised by NTEA. As a general matter, we believe that it is neither necessary nor would it be appropriate to exclude all multi-stage vehicles from roof crush resistance requirements. The purpose of FMVSS

No. 216 is to improve occupant safety in the event of a rollover. If a multi-stage vehicle is involved in a rollover, the vehicle's roof strength will be an important factor in providing occupant protection. Therefore, while we seek to address the special needs and circumstances of multi-stage manufacturers, we decline to provide any blanket exclusion for all multi-stage vehicles. We will address the issues raised by that commenter separately for multi-stage vehicles built on chassis-cab incomplete vehicles, multi-stage trucks with a GVWR greater than 2,722 kilograms (6,000 pounds) not built on a chassis cab and not built on an incomplete vehicle with a full exterior van body, and other multi-stage vehicles not built on chassis cabs.

Multi-stage vehicles built on chassis-cab incomplete vehicles.

A chassis-cab is an incomplete vehicle, with a completed occupant compartment, that requires only the addition of cargo-carrying, work-performing, or load-bearing components to perform its intended functions. As such, chassis-cabs have intact roof designs. Chassis-cabs are based on vehicles that are sold as complete vehicles, e.g., medium and full size pickup trucks, so their roof structure will be designed to meet the upgraded requirements of FMVSS No. 216.

After considering the comments of NTEA, we believe that final stage manufacturers can rely on the incomplete vehicle documents (IVD) for pass-through certification of compliance with FMVSS No. 216 for vehicles built using chassis cabs. To do this, final stage manufacturers will need to remain within specifications contained in the IVD. Since the stringency of FMVSS No. 216 is dependent on a vehicle's unloaded vehicle weight, the final stage manufacturer would need to remain within the specification for unloaded vehicle weight. If they did not, the roof would not likely have the strength to comply with FMVSS No. 216. Also, final stage manufacturers will need to avoid changes to the vehicle that would affect roof strength.

We note that some changes made by final stage manufacturers could affect the ability to conduct an FMVSS No. 216 test, e.g., for a truck, the addition of a cargo box structure higher than the occupant compartment, which could interfere with the placement of the FMVSS No. 216 test device. To address this concern, we are including a specification in the final rule that such structures are removed prior to testing. (They are still counted as part of a vehicle's unloaded weight.)

Multi-stage trucks with a GVWR greater than 2,722 kilograms (6,000 pounds) not built on a chassis cab and not built on an incomplete vehicle with a full exterior van body.

We have decided to exclude from FMVSS No. 216 a very limited group of multi-stage trucks with a GVWR greater than 2,722 kilograms (6,000 pounds), ones not built on a chassis cab and ones not built on an incomplete vehicle with a full exterior van body. We note that some incomplete vehicles with a full exterior van body might not be included in the definition of chassis-cab but would still have an intact roof design.

For the reasons discussed in the previous section, final stage manufacturers can rely on the IVD for pass-through certification of compliance with FMVSS No. 216 for vehicles built using chassis cabs. For multi-stage trucks built on an incomplete vehicle with a full exterior van body, the manufacturer can rely on either the IVD for pass-through certification of compliance with FMVSS No. 216, or use the FMVSS No. 220 option. Since the incomplete vehicle will have an intact roof design and will be similar to ones sold as non-multi-stage vehicles, the roof will have been designed to comply with FMVSS No. 216. Therefore, it is likely that the final stage manufacturer can pass through FMVSS No. 216 certification. Since the vehicle at issue will be based on an incomplete vehicle with a full exterior van body, the FMVSS No. 220 procedure is likely to also be an appropriate one for the final stage vehicle.

We are concerned, however, that for other multi-stage trucks, e.g., van cutaways, there may be practicability problems for final stage manufacturers. Because the incomplete vehicle will not have an intact roof and because the strength of the roof may be dependent on the structure to be added by the final stage manufacturer, the incomplete vehicle manufacturer may not provide IVD or similar information that would permit pass-through certification. Moreover, the design of the completed truck may be such that it is not possible to test the vehicle to FMVSS No. 216 (due to interference with the FMVSS test device) or inappropriate for testing with FMVSS No. 220. As noted earlier, the FMVSS No. 220 test was designed for school buses and uses a horizontal plate over the driver and passenger compartment instead of the angled plate of Standard No. 216. This test may not be appropriate for a truck with a cargo box that is higher than the occupant compartment.

Given these practicability issues, we have decided to exclude this limited

group of multi-stage trucks from the requirements of FMVSS No. 216.

Other multi-stage vehicles not built on chassis cabs.

For other multi-stage vehicles not built on chassis cabs, we continue to believe, for the reasons discussed in the NPRM, that permitting FMVSS No. 220 as an option is a reasonable way to balance the desire to respond to the needs of multi-stage manufacturers and the need to increase safety in rollover crashes. As we noted, several states already require “para-transit” vans and other buses, which are typically manufactured in multiple stages, to comply with the roof crush requirements of FMVSS No. 220. We also note that RVIA supported our proposal.

Multi-stage vehicles and complete vehicles with a GVWR greater than 2,722 kilograms (6,000 pounds) which have been changed by raising their original roof.

In response to the comments of NMEDA, we agree that the FMVSS No. 220 option should be available to multi-stage and complete vehicles with a GVWR greater than 2,722 kilograms (6,000 pounds) which have been changed by raising their original roof.

In considering this issue, we note that in 1999 the agency published a final rule (64 FR 22567) that was in part in response to an RVIA petition to allow vans, motor homes and other multipurpose vehicles with raised roofs the option to certify to FMVSS No. 220. The RVIA had argued first that since raised roof vehicles would have met FMVSS No. 216 requirements prior to modification of their roofs, the A-Pillar strength has already been demonstrated. Second, RVIA had claimed that the modifications usually do not affect the roof strength near the A-pillar. RVIA believed that the FMVSS No. 220 test procedure could be used to test the strength of the entire modified vehicle roof without repeating the FMVSS No. 216 certification test. In the final rule, we stated that we disagreed with RVIA’s analysis that concluded FMVSS No. 220 is comparable to FMVSS No. 216 and is preferable for testing vehicles with raised or modified roofs. We stated that that the agency stood by its tentative conclusions stated in the NPRM that the FMVSS No. 220 test is less stringent than FMVSS No. 216 for testing the appropriate roof area.

In considering the issues raise by NMEDA, we note that the discussion we included in the 1999 final rule was in the context of the version of FMVSS No. 216 that existed at that time. The standard was applicable to vehicles with a GVWR of 2,722 kilograms (6,000

pounds) or less. Here we are discussing vehicles with a GVWR greater than 2,722 kilograms (6000 pounds).

We believe that practicability issues arise for vehicles with a GVWR greater than 2,722 kilograms (6,000 pounds) whose roofs are raised. Moreover, we believe that the FMVSS No. 220 option is appropriate for the “para-transit” vans and buses. The FMVSS No. 220 option will help ensure that these occupants are afforded a level of protection that is currently not required. We are not providing this option to vehicles with raised roofs and a GVWR of less than or equal to 2,722 kilograms (6,000 pounds).

We believe that the practicability issues for vehicle alterers which raise roofs on the vehicles at issue are comparable to those of final stage manufacturers. An alterer may raise a roof on a vehicle that was originally certified to FMVSS No. 216. We believe that permitting alterers which raise roofs on these vehicles the option of certifying to FMVSS No. 220 balances potential practicability issues with the need to increase safety in rollovers.

The FMVSS No. 220 130 mm (5.1 inches) limit of platen travel established at the point of contact with the raised roof is consistent with FMVSS No. 216 requirements. As discussed elsewhere in this document, we are maintaining the current platen travel requirement as well as adding a headroom requirement in FMVSS No. 216. Therefore, even if a roof is raised and the manufacturer or alterer selects the FMVSS No. 220 option, we believe the platen travel requirement should be the same, even if there is additional headroom.

In arguing for an alternative requirement in this area, NMEDA raised a concern about higher center of gravity. NMEDA surveyed its members to obtain, amongst a number of things, an estimate of the height of raised roofs. It found that some raised roofs can be as high as 762 mm (30 inches). It was concerned about the resulting center of gravity’s effect on rollover propensity of these vehicles.

We note that in raising the roof of a vehicle, a final stage manufacturer or alterer will likely increase the center of gravity of the vehicle, independent of any roof crush resistance requirements. We believe that it is important that manufacturers carefully analyze the impacts of their changes, and choose appropriate vehicles for such modifications. We also believe that if final stage manufacturers or alterers raise the roof of a vehicle, it is still necessary that the vehicle have appropriate roof strength to provide protection in potential rollovers.

As to NMEDA’s specific recommendation, we believe that organization has not demonstrated a need for a different requirement in this area. According to that organization, the typical height of a raised roof is 356–406 mm (14–16 inches). Its members have designed raised roofs that meet FMVSS No. 220, and FMVSS No. 216 as amended will permit this option. In addition, vans which are typically altered or modified in this manner will have an electronic stability control system as standard equipment. Also, different vehicles can be used for higher raised roofs, i.e., those with dual rear wheels. We note that the GVWR of those vehicles is greater than 4,536 kg (10,000 pounds) and FMVSS No. 216 would not apply.

d. Other Issues

1. Convertibles and Open Bodied Vehicles

Convertibles are excluded from the requirements of FMVSS No. 216. In the NPRM, we sought to clarify the definition and scope of exclusion for convertibles.

We explained that FMVSS No. 216 does not define the term “convertible.” We noted, however, that S3 of 49 CFR 571.201 defines convertibles as vehicles whose A-pillars are not joined with the B-pillars (or rear-most pillars) by a fixed, rigid structural member. In a previous rulemaking, NHTSA stated that “open-body type vehicles”⁴³ are a subset of convertibles and are therefore excluded from the requirements of FMVSS No. 216.⁴⁴

We stated in the NPRM that we had reassessed our position with respect to “open-body type vehicles.” Specifically, we believed that we were incorrect in stating that “open-body type vehicles” are a subset of convertibles because some open-body type vehicles do not fall under the definition of convertibles in S3 of FMVSS No. 201. We cited the example of a Jeep Wrangler, which we believed to have a rigid structural member that connects the A-pillars to the B-pillars.

We stated in the NPRM that we believe that “open-body type vehicles are capable of offering roof crush protection over the front seat area.” Accordingly, we proposed to limit the exclusion of convertibles from the requirements of FMVSS No. 216 to only those vehicles whose A-pillars are not

⁴³ An open-body type vehicle is a vehicle having no occupant compartment top or an occupant compartment top that can be installed or removed by the user at his convenience. See Part 49 CFR 571.3.

⁴⁴ See 56 FR 15510 (April 17, 1991).

joined with the B-pillars, thus providing consistency with the definition of a convertible in S3 of FMVSS No. 201. We proposed to add the definition of convertibles contained in S3 of 49 CFR § 571.201 to the definition section in FMVSS No. 216.

Comments

The agency received comments on this issue from Advocates, the Alliance, AIAM, BMW, DaimlerChrysler, Ferrari and Porsche. Vehicle manufacturers supported continuing to exclude convertibles from the requirements; however they raised some concerns with regard to the proposed definition. The Alliance commented that there is no evidence that it is practicable for convertibles or open body vehicles to comply.

DaimlerChrysler disagreed with the agency's position that the Wrangler is not a convertible. It claimed that the Wrangler does not have an A-pillar, since the structure is not rigid and is hinged to fold down. Further, that company stated that the padded tube connecting the windshield frame and the sport bar is not rigid because it is attached with easily-removable screws.

Several commenters addressed the proposed definition of convertible. Ferrari suggested that the definition of convertible include "above the window opening light lowermost point." AIAM recommended two changes: to add "not permanently joined" and to make it clear that the referenced connection is "above the lowest point of the side window opening." This would lead to the following complete definition: "A convertible is a vehicle whose A-pillars are not permanently joined with the B-pillars (or rearmost pillars) by a fixed, rigid structural member above the lowest point of the window opening." DaimlerChrysler suggested changing the convertible definition to "vehicles with folding tops or removable hardtops with A-pillars not joined to the B-pillars (or rearmost pillars) or joined with removable parts to the B-pillars (or rearmost pillars)."

Advocates disagreed with excluding convertibles from FMVSS No. 216 and stated further that the agency should establish rollover requirements for convertibles that limit ejections and head and neck injuries.

Agency Response

After considering the comments, we are adopting the proposed definition of convertible for the final rule and we are continuing to exclude convertibles within that definition from the FMVSS No. 216 requirements. This includes retractable hard top convertibles. We

believe that to establish a roof crush requirement on vehicles that do not have a permanent roof structure would not be practical from a countermeasure perspective. A convertible roof would have to be strong enough to pass the quasi-static test, yet flexible enough to fold into the vehicle. Since we are not aware of any such designs, we do not agree with Advocates on this point. We also note that new rollover and ejection requirements for convertibles are outside the scope of this rulemaking.

On the issue of open-body vehicles, we agree with DaimlerChrysler that the agency misidentified the Wrangler as an open-body vehicle in the NPRM when it should have been considered a convertible (since the A-pillar is not rigid and fixed to the B-pillar or other rearmost pillar). At the time, we were unaware that the windshield and support bars were designed to be disassembled.

Our position on open-body vehicles has not changed. Under the new definition, open-body vehicles will be subject to FMVSS No. 216, since they are capable of offering roof crush protection over the front seat area. We note, however, that given DaimlerChrysler's comment about the Jeep Wrangler, we are not aware of other vehicles currently available for sale that are considered open-body vehicles.

We disagree with the Alliance's assertion that it is not practicable for open-body vehicles to meet the requirements of FMVSS No. 216. We believe that if a vehicle otherwise similar to the Wrangler had roof supports that are fixed (as in a roll cage), it should be capable of providing protection to the occupants as required by today's final rule.

We are also not making the changes to the proposed definition of convertible suggested by some commenters. The definition proposed was previously adopted in FMVSS No. 201 (62 FR 16725), and the agency believes the applicability is the same and is unaware of any concerns. Furthermore, we do not believe further specificity is warranted given our revised position on the Wrangler. We believe our discussion in the NPRM concerning the Wrangler may have caused confusion. We also do not agree that there is a need to specify that convertibles have folding hardtops or removable hardtops. These roof systems are not intended as significant structural elements but are designed primarily to provide protection from inclement weather, improve theft protection and are generally offered as a luxury item. These types of roof systems are also designed of lighter weight materials, such as aluminum or composites, for

ease of folding and storage within the vehicle or removal by the consumer. and we believe consumers readily recognize they will afford the occupants limited protection in a rollover.

2. Vehicles Without B-Pillars

In the NPRM, we did not specifically discuss vehicles that are designed without B-pillars. At the time we were unaware of any technical concerns the manufacturers might have with these vehicles, to meet the proposed requirements.

Ford identified a number of design challenges for vehicles without B-pillars. That company's concerns were focused on pickup trucks without B-pillars that have a GVWR of 3,856 kilograms (8,500 pounds) or more. These vehicles have a front-forward opening and a rear-rearward opening side door configuration that latch together without a fixed, structural B-pillar. Ford expressed concern that there is no direct load path to resist the platen during testing and as a result, there are significant design and manufacturing issues that must be addressed while avoiding a major incremental weight penalty. Ford did not make any specific recommendations.

Agency Response

We agree with Ford's analysis that certain vehicles without B-pillars may raise additional technical challenges compared to other vehicles, particularly for heavier vehicles. However, based upon our fleet testing, we believe that a structure can be designed at the joint between the doors that acts as a surrogate B-pillar to resist roof displacement during testing. We note that the Alliance's comments on how the proposed tie-down procedure adversely affects vehicles without B-pillars reinforce this view. The revised tie-down procedure for the final rule will aid vehicles without B-pillars in complying since support will be placed along the complete body sill.

NHTSA tested two vehicles without B-pillars, the 2004 Chevrolet Silverado HD and 2005 Nissan Frontier. This testing confirmed that the load can be successfully transferred to the joint between adjacent doors where a B-pillar would be in a conventional vehicle design. The Silverado did not meet the 2.5 SWR proposed in the NPRM, but it did exceed 1.5. The Frontier achieved a peak SWR of almost 4.0 within the allocated platen displacement.

While we appreciate the challenges manufacturers will incur to meet the new requirements, we believe the upgrade is feasible for vehicles without B-pillars. We note that one of the

reasons we are providing a phase-in is to permit manufacturers additional time to make the design changes needed to enable some of the more challenging vehicles to comply with the requirements of the final rule.

3. Heavier Vehicles With a High Height to Width Aspect Ratio

The Alliance and Mercedes-Benz USA requested that vehicles with a GVWR above 3,856 kilograms (8,500 pounds) GVWR and a height to width aspect ratio greater than 1.2 be permitted to certify to FMVSS No. 220 as an option or, at a minimum, use the larger platen specified for FMVSS No. 220. They argued that the FMVSS No. 216 platen results in unrealistic roof deformation for these particular vehicles.

Agency Response

While we have considered this comment, we believe that the commenters have not provided persuasive evidence that a special requirement is needed for these vehicles. While we did observe edge contact in our testing of the Sprinter, it was not of a nature that prevents compliant designs. We note that the 1.5 SWR we are adopting for vehicles within this weight range reduces possible concerns in this area.

4. Active Roofs

Autoliv North America (Autoliv) stated that the quasi-static test procedure does not have a provision for active roof structure systems. Active roof structures are being developed to provide added stiffness during an actual rollover event. The effectiveness of such a system may be transient, deployed during a rollover initiation and lasting only as long as required to reduce intrusion. The quasi-static test specifies a deformation rate of not more than 13 millimeters per second with the total time for crush not to exceed 120 seconds. According to Autoliv, the duration of this test may exceed the time in which certain active roof structures can be effective.

Agency Response

We are not aware of the near term implementation or effectiveness of active roof structure technology. In developing performance requirements, we seek to develop ones that are appropriate for, and do not unnecessarily discourage, new technologies. However, our ability to do this is dependent on the amount of information we have. We do not have sufficient information at this time to indicate the quasi-static test will

prevent implementation of active roof systems.

5. Whether an Additional SNPRM Is Needed

Several commenters argued that the agency's January 2008 SNPRM did not provide sufficient information about the alternatives we were considering and that an additional SNPRM should be published.

Public Citizen claimed that the January 2008 SNPRM failed to provide enough information for meaningful public comment. It stated that the agency did not spell out the explicit safety benefits of mandating a two-sided test, or how using the one-sided test would meet the statutory requirement relating to roof strength for driver and passenger sides. Public Citizen argued that a new SNPRM is needed.

Advocates claimed that the January 2008 SNPRM offered several regulatory alternatives without support from a cost-benefits analysis. That commenter stated that this denied the public an opportunity to evaluate the agency's comparative estimates of costs and benefits before submitting comments. Advocates argued that the SNPRM did not fulfill agency's obligation to present the public with the regulatory alternatives it is considering.

The ALAM stated that it believes there would not be a fair opportunity for public comment on a two-sided test requirement without an opportunity of review of revised cost-benefit analysis.

Agency Response

We reject the commenters' arguments that the agency did not provide a meaningful opportunity for comment. In conjunction with the August 2005 NPRM, the agency's PRIA included an assessment of the 2.5 and 3.0 SWR alternatives. As discussed above, in our January 2008 SNPRM, we asked for public comment on a number of issues that might affect the content of the final rule, including possible variations in the proposed requirements. We also announced the release of the results of various vehicle tests conducted since the proposal. In the SNPRM, we noted that we had been carefully analyzing the numerous comments we had received on the NPRM, as well as the various additional vehicle tests, including both single-side tests and two-sided tests, conducted since the NPRM. We invited comments on how the agency should factor the new information into its decision. We noted that while the NPRM focused on a specified force equivalent to 2.5 times the unloaded vehicle weight, the agency could adopt a higher or lower value for the final rule.

We explained, with respect to two-sided vehicle testing, that we believed there was now sufficient available information for the agency to consider a two-sided requirement as an alternative to the single-sided procedure described in the NPRM. We stated that we planned to evaluate both the single-sided and two-sided testing alternatives for the final rule and requested comments that would help us reach a decision on that issue.

While the agency did not provide complete new cost-benefits analyses to accompany the SNPRM, we included a detailed discussion in the SNPRM of how estimated impacts of the final rule would be changed by a number of relevant factors. See 73 FR 5488-5490. These factors included the pass/fail rate of the vehicle fleet, the impact of the ESC standard on potential benefits, revised cost and weight estimates, two-sided testing implications, and other factors.

Thus, in the NPRM and SNPRM, we provided detailed information concerning the alternatives we were considering and the relevant issues. We also note that both Public Citizen and Advocates supported a two-sided test requirement, the alternative we are adopting in today's rule.

6. Rear Seat Occupants

As a general comment to the NPRM, the Advocates raised a concern that the quasi-static platen test is not applicable to rear seat occupants including small children seated in the rear.

Agency Response

We note that the large size of the FMVSS No. 216 platen covers the rear seat in most vehicles to help ensure protection for rear seat occupants. We believe that one of the countermeasures that vehicle manufacturers will use to meet the upgraded roof strength requirements is strengthening the B-pillars. In terms of possible benefits to small children, belted occupant injuries sustained due to rollover roof crush are to the head, neck, and face from contact with roof structures. Appropriately restrained children are generally not tall enough to sustain such injuries.

7. New Car Assessment Program (NCAP)

Several commenters suggested that the agency develop a 5-star rating system concerning roof strength for our NCAP program to provide the public with information on roof strength and to encourage manufacturers to improve the roof strength of their vehicles.

Agency Response

The purpose of this rulemaking is to upgrade our roof strength standard. The issue of whether roof strength might be addressed in some way in our NCAP program would be considered separately in the context of that program.

8. Possible Energy Requirement

We did not propose an energy requirement in the NPRM but indicated that we would welcome comments on an energy absorption test that had previously been suggested by SAFE and Syson-Hille and Associates (Syson).

Agency Response

We received several comments. We appreciate the information provided in the comments but note that we are not considering rulemaking in this area.

9. Advanced Restraints

In the NPRM, we presented a summary of our advanced restraints research and requested comments in this area.

Agency Response

While advanced restraints are not part of this rulemaking, the agency is continuing research in this area and appreciates the comments that were provided.

VII. Costs and Benefits

At the time of the NPRM, the agency prepared a PRIA describing the estimated costs and benefits of the proposal. While the agency did not provide complete new cost-benefits analyses to accompany the SNPRM, we included a detailed discussion in the SNPRM of how estimated impacts of the final rule would be changed by a number of relevant factors. See 73 FR 5488–5490. These factors included the pass/fail rate of the vehicle fleet, the impact of the ESC standard on potential benefits, revised cost and weight estimates, two-sided testing implications, and other factors.

Many commenters addressed the PRIA and the later discussion of these impacts included in the SNPRM. Among other things, commenters addressed the target population, the pass/fail rate of the current fleet, cost and weight impacts, and estimates of benefits.

The agency addresses the comments concerning its analysis of costs and benefits in detail in the FRIA. In this document, we summarize the agency's estimates of costs and benefits and discuss the comments concerning target population and roof crush as a cause of injury.

a. Conclusions of the FRIA

The conclusions of the FRIA can be summarized as follows:

Countermeasures

The agency believes that manufacturers will meet this standard by strengthening reinforcements in roof pillars, by increasing the gauge of steel used in roofs, and/or by using higher strength materials. The agency believes that pressure to improve fuel economy in vehicles, driven by more stringent Corporate Average Fuel Economy (CAFE) standards as well as by market forces, together with safety considerations, will provide a strong incentive for manufacturers to achieve increased roof strength through use of light weight materials and stronger roof designs initiated during the redesign cycle. The agency believes that the phase-in schedule provided in this rule will allow manufacturers to establish such designs in an efficient manner. The agency estimates that about 82 percent of all current passenger car and light truck models with GVWRs less than 2,722 kilograms (6,000 pounds) will need changes to meet the 3.0 SWR requirement, and that 40 percent of vehicles over 2,722 kilograms (6,000 pounds) GVWR will need changes to meet the 1.5 SWR requirement.

Benefits

The agency estimates that the changes in FMVSS No. 216 will prevent 135 fatalities and 1,065 nonfatal injuries annually.

Costs

The design changes made to comply with higher test load requirements will add both cost and weight to the vehicle. This will increase the initial purchase price and will increase lifetime fuel usage costs.

Taking account of both the costs of design changes and lifetime fuel usage costs, the agency estimates that compliance with the upgraded roof strength standard will increase lifetime consumer costs by \$69–\$114 per affected vehicle. Redesign costs are expected to increase affected vehicle prices by an average of about \$54. Added weight is estimated to increase the lifetime cost of fuel usage by \$15 to \$62 for an average affected vehicle. The range in fuel costs reflects different discount rate assumptions of 7% and 3%, as well as a range of assumptions regarding the ability of manufacturers to incorporate advanced weight saving technology into their redesigned fleet. Total consumer costs are expected to range from \$875 million to \$1.4 billion annually.

Cost Effectiveness and Net Benefits

Cost effectiveness is a measure of the economic investment that is required to

prevent a fatality. The cost effectiveness of this rule was estimated under both 3% and 7% discount rate assumptions for each alternative. Nonfatal injuries were translated into fatality equivalents based on comprehensive valuations that included both economic impacts and valuations of lost quality of life. To reflect the present value of benefits that would be experienced over the vehicle's useful life, the resulting equivalent fatalities were discounted over the vehicle's life based on annual exposure to crash involvement as measured by annual miles traveled. The 135 fatalities and 1,065 nonfatal injuries that will be prevented translate into 190 equivalent fatalities, which are valued at 156 equivalent fatalities under a 3% discount rate, and 125 equivalent fatalities under a 7% discount rate. When compared to total costs, the results indicate that the new standard will cost from \$6.1 million to \$9.8 million per equivalent life saved.

Net benefits represent the difference between total costs and the total monetary value of benefits. DOT's guidance specifies a value of \$5.8 million as the value of a statistical life (VSL), with a range of uncertainty covering \$3.2 million to \$8.4 million. The monetary value of benefits was estimated by assigning a value of \$6.1 million to each equivalent fatality prevented. This value includes the \$5.8 million VSL plus approximately \$300,000 of economic savings to represent the comprehensive societal benefit from preventing a fatality. This means that the standard would be considered to result in net benefits only if the cost per equivalent life saved was below \$6.1 million.

Net benefits represent the difference between total costs and the total monetary value of benefits. The monetary value of benefits was estimated by assigning a value of \$6.1 million to each equivalent fatality prevented. This value consists of a value per statistical life saved (VSL) of \$5.8 million plus \$300,000 in economic costs prevented. For the 3.0/1.5 load requirements of the final rule, the net impact would range from a net benefit of \$6 million to a net loss of \$458 million. Using an alternate comprehensive value of \$8.7 million (which consists of a VSL of \$8.4 million plus \$300,000 in economic savings), the standard could result in a net benefit of \$388 million to a net loss of \$151 million. Using an alternate comprehensive value of \$3.5 million (which consists of a VSL of \$3.2 million plus \$300,000 in economic savings), the standard could result in a net loss ranging from \$376 million to \$824

million. These impacts are disproportionately influenced by the relatively large contributions to costs and small contributions to benefits from

vehicles over 6,000 lbs. GVWR. Nearly all alternatives covering vehicles from 6,001 to 10,000 lbs. GVWR yield net losses rather than net savings to society.

The following table summarizes the cost and benefits of this final rule.

TABLE 2—COST AND BENEFIT SUMMARY

Total Cost	\$875 to \$1,391 million.
Cost per Affected Vehicle	\$69 to \$114.
Benefits	135 fatalities, 1,065 injuries, 190 equivalent fatalities.
Cost per Equivalent Life Saved	\$6.1 million to \$9.8 million.
Net Benefits	\$6 million to –\$458.

b. Comments

Target Population

The agency received numerous comments concerning the target population. CAS and Advocates argued that improving roof strength would impact ejection and that mitigated ejections should therefore be included in the agency’s benefit calculations. Advocates also argued that rear seat occupants should be covered by the revised standard. SAFE argued that roof crush increases the likelihood of glass fracture and vehicle structure deformation, thereby increasing the possibility of ejection. It also argued that roof crush reduces the effectiveness of restraint systems, decreases the effectiveness of rollover air curtains, and decreases the ability of occupants to be extricated from the vehicle. The Xprts disagreed with several of NHTSA’s target population restrictions. It stated that ejected occupants, rear seat occupants, and children under 12 should be included. It also argued that roof crush can cause thoracic and spinal injuries, and that upper extremity injuries from ejection through side windows should also be included. Many of these arguments were repeated in a separate submission by CFIR signed by one of the Xprts authors. Consumers Union and Public Citizen also argued that stronger roofs would reduce ejections and better maintain the performance of other safety features such as safety belts, air bags, and door locks. Public Citizen also argued that unbelted occupants would benefit from stronger roofs.

Agency response. We begin our response by noting that Table 1, set forth earlier in this document, shows a breakdown of the target population that could potentially benefit from roof crush improvements.

To examine the inclusion of different categories of injuries in the target population, the agency has conducted several analyses of ejections in rollovers. The first study was a statistical analysis examining the relationship between intrusion and

ejection. In this study,⁴⁵ Strashny examined 36 different Probit models examining belted cases, unbelted cases, complete ejections, all ejections (including both complete and partial ejection), continuous models, dichotomous models, adjusted models based on both quarter turns and roof exposures, as well as unadjusted models. In all, there were 18 models for complete ejections and 18 for all ejections. Strashny found that there was no significant relationship between the level of intrusion and the probability of complete ejection in any of the 18 full ejection models. For all ejections, which include partial ejections, he found some level of significance for 8 of the 18 models, indicating that a minority of the models found a possibility that some partial ejections might be influenced by stronger roofs. However, 12 of the models found no statistically significant relationship between intrusion and all ejections. We note that partial ejections that meet the other inclusion criteria are a part of the target population for this rulemaking.

The agency then conducted a detailed examination of all fatal complete ejection cases that were excluded from the target population. A panel of three NHTSA safety engineers independently examined each case to determine whether (a) for ejections through open doors, there was deformation in the door latch area where the root cause could be directly attributed to roof crush, and (b) for ejections through windows, if the broken glass through which the occupant was ejected was directly related to deformation of the roof rather than dynamic crash impulse loads or side window/door to ground contact. The panel concluded that there were no cases that met either of these criteria. Therefore, based on these findings and Strashny’s finding of no statistically significant correlation between intrusion and ejection probability, all cases of total ejection

were excluded from the target population unless their MAIS level injury occurred inside the vehicle prior to ejection.

For occupants who were unbelted but not fully ejected, we could not establish a relationship between roof crush injuries and the magnitude of roof crush. Strashny analyzed the relationship between intrusion and injuries to unbelted occupants and found no significant correlation. This is not unexpected because unbelted occupants essentially become flying objects inside vehicles as they roll over, and head injuries can occur at multiple interior locations. Therefore, only belted occupants are included in the target population.

Regarding the other categories of injuries noted in the comments, partially ejected occupants were already included in the target population, and the agency has decided to include rear seat occupants in the target population. We note that B pillar strength upgrades were included in all of our finite element countermeasure analyses, and this support also provides protection for rear occupants. Moreover, vehicle schematics submitted by both industry and contractors indicate that some design solutions contemplated for increased roof strength include not only stronger A- and B-pillars but also a stronger B- to C-pillar load path to resist platen movement. Such solutions may benefit rear seat occupants as well as front seat occupants. The agency has also decided to include belted children in the target population.

Roof Crush as a Cause of Injury

A number of commenters including GM, Ford, Nissan, and SAFE stated that the statistical correlation Strashny found between roof intrusion and injury does not establish a causal relationship between roof deformation and injury. SAFE stated that the studies by both Rains and Strashny merely suggest that there is a relationship. SAFE stated that “ * * * when you compare rollover accidents that have significant roof/ pillar deformation with other rollover

⁴⁵ Strashny, Alexander, “The Role of Vertical Roof Intrusion in Predicting Occupant Ejection,” National Center for Statistics and Analysis, 2009.

accidents that have very little or no roof/pillar deformation, you are not comparing similar accidents with respect to roof-to-ground impact severity. Just the fact that two vehicles are in a rollover with greater than 2 quarter turns does not mean they are in the same or even similar impact severities." SAFE also noted an earlier study (matched pair comparison project) in which production and roll bar-equipped vehicles were tested where the comprehensive forces measured on test dummies were similar regardless of the vehicle roof crush. Ford stated that "The amount of roof deformation is only an indication of the severity of the impact between the roof and the ground * * *." GM stated that "Observations of injury occurrence at the end of a rollover collision reveal nothing regarding the relationship of roof deformation, roof strength, or roof strength-to-weight ratio injury causation." Nissan stated that deformation and injury severity are both independently associated with roof impact severity.

Agency Response

The agency agrees that as a general principle, a statistical correlation does not in itself prove that a causal relationship exists. However, the Strashny study was designed with a strict focus to only include injury scenarios where the intruding roof was the injury source. The study compared cases where there was intrusion to cases where there was no intrusion and found that as intrusion increases, the probability of, and severity of injury also increases. The study controlled for crash severity using quarter turns, which is the best available metric for rollover severity. Contrary to SAFE's contention, the study does not compare crashes over 2 quarter turns as a group. Rather, it compares only crashes of similar severity as defined by each iterative quarter turn exposure. Thus, a vehicle that experienced 3 quarter turns would only be compared to other vehicles that experienced 3 quarter turns. SAFE's and Ford's arguments appear to imply that any difference in roof intrusion must be due to a difference in impact severity rather than roof strength or design, whereas the Strashny study, by controlling for quarter turns, attempts to minimize differences due to impact severity. Further, the study included only belted cases which minimized the impact of "diving" as an injury cause.

There are logical reasons to believe that a collapsing roof that strikes an occupant's head at the nearly instantaneous impact velocity

experienced when structures deform might cause serious injury. These types of injuries were documented by Rechnitzer and Lane in a detailed investigation of 43 rollover crashes.⁴⁶ The agency believes that the statistically significant relationship between roof intrusion and belted occupant injury found in the Strashny study indicates not just a suggestion, but a probability that increasing roof strength reduces injuries.

Regarding the SAFE matched pair comparison project, the agency notes that the dummy necks used in the tests were not biofidelic. They are rigid structures that do not allow for the normal bending that occurs in the human spine. The agency believes that lateral bending plays an important role in determining the degree of injury sustained by humans in rollovers, and does not view these results as an adequate assessment of injury in humans during rollover crashes.

VIII. Rulemaking Analyses and Notices

a. Executive Order 12866 (Regulatory Planning and Review) and DOT Regulatory Policies and Procedures

The agency has considered the impact of this rulemaking action under Executive Order 12866 and the Department of Transportation's regulatory policies and procedures. This rulemaking is economically significant and was reviewed by the Office of Management and Budget under E.O. 12866, "Regulatory Planning and Review." The rulemaking action has also been determined to be significant under the Department's regulatory policies and procedures. The FRIA fully discusses the estimated costs and benefits of this rulemaking action. The costs and benefits are summarized in section VII of this preamble, *supra*.

b. Regulatory Flexibility Act

The Regulatory Flexibility Act of 1980, as amended, requires agencies to evaluate the potential effects of their proposed and final rules on small businesses, small organizations and small governmental jurisdictions. I hereby certify that this rule will not have a significant economic impact on a substantial number of small entities. Small organizations and small governmental units will not be significantly affected since the potential cost impacts associated with this action will not significantly affect the price of new motor vehicles.

⁴⁶Rechnitzer, George and Lane, John, "Rollover Crash Study, Vehicle Design and Occupant Injuries", Monash University, 1994.

The rule directly affects motor vehicle manufacturers, second stage or final manufacturers, and alterers. The majority of motor vehicle manufacturers would not qualify as a small business. There are six manufacturers of passenger cars that are small businesses.⁴⁷ These manufacturers, along with manufacturers that do not qualify as a small business, are already required to comply with the current requirements of FMVSS No. 216 for vehicles with a GVWR of 2,722 kilograms (6,000 pounds) or less. Improving performance as necessary to meet the upgraded requirements, and for the requirements for heavier light vehicles, can be achieved by means including strengthening reinforcements in roof pillars, by increasing the gauge of steel used in roofs and by using higher strength materials.

All of these small manufacturers could be affected by the upgraded requirements. However, the economic impact upon these entities will not be significant for the following reasons.

(1) Potential cost increases are very small compared to the price of the vehicles being manufactured and can be passed on to the consumer.

(2) Some of the vehicles manufactured by these small businesses are convertibles not subject to this requirement.

(3) The rule provides several years leadtime, and small volume manufacturers are given the option of waiting until the end of the phase-in (until September 1, 2015) to meet the upgraded requirements for lighter vehicles. All manufacturers are given until September 1, 2016 to meet the requirements for the heavier light vehicles.

Most of the intermediate and final stage manufacturers of vehicles built in two or more stages and alterers have 1,000 or fewer employees. Some of these companies already are required to comply with the current requirements of FMVSS No. 216 for vehicles with a GVWR of 2,722 kilograms (6,000 pounds) or less. We have included several provisions in the final rule to address the special needs of multi-stage manufacturers and alterers. While the number of these small businesses potentially affected by this rule is substantial, the economic impact upon these entities will not be significant for the following reasons:

(1) We are providing a FMVSS No. 220 option for multi-stage vehicles, except those built on chassis-cab incomplete vehicles, and for vehicles

⁴⁷Fisker, Mosler, Panoz, Saleen, Standard Taxi, Tesla.

which are changed in certain ways to raise the height of the roof. This aspect of our rule affords significant economic relief to small businesses, some of which are already required by States to certify to the requirements of FMVSS No. 220.

(2) Small businesses using chassis cabs will be in position to take advantage of "pass-through certification," and therefore are not expected to incur any additional expenditures.

(3) We are excluding a narrow category of multi-stage vehicles from FMVSS No. 216 altogether, multi-stage trucks built on incomplete vehicles other than chassis cabs.

(4) Some of the vehicles manufactured by these small businesses are convertibles.

(5) Final stage manufacturers and alterers can wait until one year after the end of the phase-in to meet the new requirements.

Accordingly, there will not be a significant economic impact on small businesses, small organizations, or small governmental units by these amendments. For these reasons, the agency has not prepared a regulatory flexibility analysis.

c. Executive Order 13132 (Federalism)

NHTSA has examined today's final rule pursuant to Executive Order 13132 (64 FR 43255, August 10, 1999) and concluded that no additional consultation with States, local governments or their representatives is mandated beyond the rulemaking process. The agency has concluded that the rule does not have federalism implications because the rule does not have "substantial direct effects on the States, on the relationship between the national government and the States, or on the distribution of power and responsibilities among the various levels of government."

Further, after careful consideration of the public comments and further analysis of the issues, NHTSA concludes that no consultation is needed to discuss the preemptive effect of today's rule. NHTSA's safety standards can have preemptive effect in at least two ways. First, the National Traffic and Motor Vehicle Safety Act contains an express preemption provision: "When a motor vehicle safety standard is in effect under this chapter, a State or a political subdivision of a State may prescribe or continue in effect a standard applicable to the same aspect of performance of a motor vehicle or motor vehicle equipment only if the standard is identical to the standard prescribed under this chapter." 49

U.S.C. 30103(b)(1). It is this statutory command that unavoidably preempts non-identical State legislative and administrative law, not today's rulemaking, so consultation would be unnecessary.

Second, the Supreme Court has recognized the possibility of implied preemption: State requirements imposed on motor vehicle manufacturers, including sanctions imposed by State tort law, can stand as an obstacle to the accomplishment and execution of a NHTSA safety standard. When such a conflict is discerned, the Supremacy Clause of the Constitution makes the State requirements unenforceable. *See Geier v. American Honda Motor Co.*, 529 U.S. 861 (2000). For the reasons explained below, the agency has reconsidered the tentative position presented in the NPRM and does not currently foresee any potential State tort requirements that might conflict with today's final rule.

In the NPRM, NHTSA considered the objectives of the proposed roof crush resistance upgrade in the context of the agency's overall rollover plan and addressed whether there might be specific conflicts between the standard and anticipated State tort law. The agency opined on the possibility that certain State tort law actions might conflict with an improved Federal roof crush resistance standard and that those conflicts could result in those actions being determined by a court to be impliedly preempted. It presented the following tentative conclusions:

- Overall, safety would best be promoted by the careful balance it had struck in the proposal among a variety of considerations and objectives regarding rollover safety.
- The proposal to upgrade roof crush resistance was a part of a comprehensive plan for reducing the serious risk of rollover crashes and the risk of death and serious injury in those crashes. The objective of the proposal was to increase the requirement for roof crush resistance only to the extent that it can be done without creating too much risk of negatively affecting vehicle dynamics and rollover propensity. Excessively increasing current roof crush resistance requirements could lead vehicle manufacturers to add weight to vehicle roof and pillars, thereby raising the vehicle center of gravity (CG) and increasing rollover propensity.

- Some methods of improving roof crush resistance are costlier than others and the resources diverted to increasing roof strength using one of the costlier methods could delay or even prevent vehicle manufacturers from equipping

their vehicles with advanced vehicle technologies for reducing rollovers.

- Either a broad State performance requirement for levels of roof crush resistance greater than those proposed or a narrower requirement mandating that increased roof strength be achieved by a particular specified means, could frustrate the agency's objectives by upsetting the balance between efforts to increase roof strength and reduce rollover propensity.

- Based on this conflict analysis, if the proposal were adopted as a final rule, all conflicting State common law requirements, including rules of tort law, would be subject to being found to be impliedly preempted.

1. Public Comments About NHTSA's Tentative Views on Conflict and Preemption

Vehicle manufacturers and one legal advocacy organization strongly supported the view that an upgraded roof crush standard would conflict with and therefore impliedly preempt State rules of tort law imposing more stringent requirements than the one ultimately adopted by NHTSA.

Consumer advocacy groups, members of Congress and State officials, trial lawyers, consultants and members of academia, and private individuals strongly opposed our view that there could be conflict. The opposing letters from State officials included one signed by 27 State Attorneys General and the National Conference of State Legislatures.

A summary of the primary arguments of the commenters on each side follows:

A. Primary Arguments for the Existence of Conflict

- There is a limit to the increases in roof crush resistance or stiffening that can practically be achieved across the fleet without introducing unacceptable risk of undesirable effects, such as increases in the height of the center of gravity of the vehicle or diverting resources away from other promising advanced vehicle technologies for reducing rollovers.

- Small additions of weight and small changes in center of gravity height will, based on NHTSA's analysis presented in Appendix A of the PRIA, have large consequences on the level of rollover risk and risk of associated fatalities and injuries. Moreover, the weight impacts of meeting requirements at different SWR levels are greater than estimated by the agency in the PRIA.

- There is a conflict between the agency's comprehensive rollover policy and some state common law rules related to roof strength. Any state

common law rule that would purport to impose a duty to design vehicles' roofs to meet a more stringent strength requirement has the potential, as a practical matter, to result in a reduction in vehicle stability (as measured by average SSF), at least for some vehicle models in the fleet. Such a result would undercut NHTSA's overall rollover mitigation policy that has been developed to balance the competing goals of preventing rollover crashes in the first place and of reducing the risk of injury when such crashes nevertheless occur.

- The creation of a patchwork of different State roof crush resistance requirements across the country would not contribute toward achievement of an appropriate balancing of roof strength and rollover propensity.

- Being required to devote resources to increasing roof strength using one of the costlier methods could delay or even prevent manufacturers from installing advanced vehicle technologies for reducing rollovers.

- The agency should also be concerned about another potential safety conflict, in the area of vehicle compatibility, as the addition of weight increases the chances of vehicle mass mismatch in a collision.

B. Primary Arguments Against the Existence of Conflict

- NHTSA's claims that a more stringent standard could result in increased vehicle weight and decreased stability are not supported by the record.

- Manufacturers can strengthen roofs by a variety of means without significantly increasing weight, and advanced steels and other lightweight materials can be used to strengthen roofs without a weight increase.

- NHTSA's data show that increases in roof structural strength will not have a physically measurable influence on CG height. Production of vehicles that exceed the NHTSA standard would enhance the safety objectives of that standard.

- NHTSA did not provide any examples of vehicles with elevated rollover risk due to weight added to the roof. An examination of the vehicle fleet, including the Volvo XC90 and vehicles with high SWRs tested after publication of the NPRM, shows that the agency's concerns are unfounded.

- The agency's statement that resources used to increase roof strength could divert resources away from other promising advanced vehicle technologies for reducing rollovers is unsupported and speculative. Manufacturers can do both.

- Given the agency's New Car Assessment Program, manufacturers would improve roof strength using design changes that avoid a lower star rating.

- The tort system would provide the best incentive for manufacturers to make design decisions that will not increase rollover propensity.

- The premise behind NHTSA's analysis is incorrect because plaintiffs alleging a design defect must prove that the alternative design would not have created more injuries in other accidents.

- The *Geier* case does not support preemption as the situation it addressed involved two key factors that are not present here: Consumer resistance to air bags and the need to foster innovation in passive restraint technology.

Preemption in this case is inconsistent with the statutory savings clause.

- The agency's statement is overbroad in being applied to all vehicles covered by the standard, without regard to their individual design characteristics or their manufacturers' ability to exceed the standard without negatively affecting vehicle dynamics and rollover propensity.

2. Preemption, *Geier* and the National Traffic and Motor Vehicle Safety Act

In *Geier*, 529 U.S. 861 (2000), the Supreme Court specifically addressed the possible preemptive effect of the National Traffic and Motor Vehicle Safety Act, taken together with Federal motor vehicle safety standards issued under that Act, on common law tort claims. The issue before the court was whether the Safety Act, together with FMVSS No. 208, preempted a lawsuit claiming a 1987 car was defective for lacking a driver air bag. When the car was manufactured, FMVSS No. 208 had required manufacturers to equip some but not all of their vehicles with passive restraints.

The conclusions of *Geier* can be summarized as follows:

- The Safety Act's provision expressly preempting state "standards" does not preempt common law tort claims. The issue of whether the term "standards" includes tort law actions is resolved by another provision in the Safety Act—the "savings" clause. That provision states that "(c)ompliance with" a Federal safety standard "does not exempt any person from any liability under common law."

- The savings clause preserves those tort actions that seek to establish greater safety than the minimum safety achieved by a Federal regulation intended to provide a floor.

- The savings clause does not bar the working of conflict preemption

principles. Nor does the preemption provision, the saving provision, or both read together, create some kind of "special burden" beyond that inherent in ordinary preemption principles that would specially disfavor pre-emption. The two provisions, read together, reflect a neutral policy, not a specially favorable or unfavorable policy, toward the application of ordinary conflict preemption principles.

- The preemption provision itself reflects a desire to subject the industry to a single, uniform set of Federal safety standards. On the other hand, the savings clause reflects a congressional determination that occasional nonuniformity is a small price to pay for a system in which juries not only create, but also enforce, safety standards, while simultaneously providing necessary compensation to victims. Nothing in any natural reading of the two provisions favors one set of policies over the other where a jury-imposed safety standard actually conflicts with a Federal safety standard.

- A court should not find preemption too readily in the absence of clear evidence of a conflict.

- The common-law "no airbag" action before the Court was preempted because it actually conflicted with FMVSS No. 208. That standard sought a gradually developing mix of alternative passive restraint devices for safety-related reasons. The rule of state tort law sought by the petitioner would have required manufacturers of all similar cars to install air bags rather than other passive restraint systems, thereby presenting an obstacle to the variety and mix of devices that the Federal regulation sought.

3. Agency Testing and Discussion

In the NPRM, we noted the well-established physical relationship between center of gravity (CG) and rollover propensity. It is reflected in our NCAP ratings program. All other things being equal, increasing the CG of a vehicle increases its rollover propensity.

We also posited a second relationship, one between CG and SWR. We identified a hypothetical fleet impact in which the weight and center of gravity effects of complying with a 2.5 SWR requirement could result in additional rollovers and added fatalities. This analysis was presented in Appendix A of the PRIA. As discussed in that document, there were various uncertainties and caveats associated with the analysis. The agency believed that manufacturers would take steps to avoid negative effects on rollover propensity.

We note that NHTSA has updated that analysis for the FRIA, addressing 2.5, 3.0 and 3.5 SWR alternatives. As discussed in the FRIA, the agency believes that, for the alternatives analyzed, manufacturers could and would take steps sufficient to avoid negative effects on rollover propensity if sufficient leadtime is provided for them to do so.

As noted earlier, NHTSA has done testing of vehicles measuring roof crush resistance performance, much of it completed after publication of the NPRM. Twelve of the vehicles tested by NHTSA after the NPRM had (one-sided) SWRs of 3.9 or higher. As part of our fleet testing, NHTSA has also tested three paired vehicles⁴⁸ for which manufacturers significantly increased SWR as part of redesigning the vehicle. In each case, SWR was increased without increasing rollover propensity as measured by SSF. In two of the cases, CG stayed about the same (it did not increase); in the other, CG did increase but other changes (track width) offset the negative effect of higher CG.

4. Agency Views About Conflict Preemption

As discussed above, the Supreme Court has recognized the possibility of implied preemption: State requirements imposed on motor vehicle manufacturers, including sanctions imposed by State tort law, can stand as obstacles to the accomplishment and execution of a NHTSA safety standard. When such a conflict is discerned, the Supremacy Clause of the Constitution makes the State requirements unenforceable.

Since implied preemption turns upon the existence of an actual conflict, we, as the agency charged with effectively carrying out the Act and possessing substantial technical expertise regarding the subject matter and purposes of the Federal motor vehicle safety standards and the Vehicle Safety Act, address whether conflicts exist in our rulemaking notices. In most rulemakings, we do not foresee the possibility of there being any state requirements that would create conflicts.

Following the principles set forth in *Geier*, we are providing our views concerning the issue of whether conflicts may exist in connection with the requirements being adopted in this final rule. We believe that this is appropriately responsive to statements by several Supreme Court justices encouraging agencies to consider and

discuss the possible preemptive effects of their rulemakings.⁴⁹

After considering the public comments on the proposal and considering today's final rule, NHTSA has reconsidered the tentative position presented in the NPRM and do not currently foresee any potential State tort requirements that might conflict with today's final rule. Without any conflict, there could not be any implied preemption.

In the NPRM, we stated that it was our tentative judgment that safety would be best promoted by the balance we had struck in the proposal among a variety of considerations and objectives regarding rollover safety. We explained that it was the objective of the proposal to increase the requirement for roof crush resistance only to the extent that it could be done without creating too much risk of negatively affecting vehicle dynamics and rollover propensity. We expressed concern that excessively increasing current roof crush resistance requirements could lead vehicle manufacturers to add weight to vehicle roof and pillars, thereby raising the vehicle center of gravity (CG) and increasing rollover propensity. As part of our tentative position, we indicated in the NPRM that a broad State performance requirement for more stringent levels of roof crush resistance could frustrate the agency's objectives by upsetting the balance between efforts to increase roof strength and reduce rollover propensity.

Based on the record for this final rule, we cannot identify a level of stringency of roof crush resistance above which tort laws would conflict. For example, we cannot say that any particular levels of roof crush resistance above those required by today's rule would likely result in unacceptable levels of rollover resistance. Similarly, we cannot identify any level of roof crush resistance above which it would be expected that net safety benefits would diminish.

As discussed earlier, there are ways of improving roof strength that avoid or minimize adding weight high in the vehicle (e.g., use of advanced lightweight materials), and there are other design characteristics that can be used to offset or eliminate any potential change in rollover stability due to increased CG (e.g., increased track width). Moreover, during our fleet testing, we observed three paired vehicles for which manufacturers

significantly increased SWR as part of redesigning the vehicle, without increasing rollover propensity as measured by SSF. Finally, while there would be increasing technical challenges for vehicle manufacturers to meet successively higher SWR levels above the alternatives we analyzed, those challenges would vary considerably depending on the nature of the vehicle, e.g., weight, size, geometry, etc., making it essentially impossible for NHTSA to define a level of roof crush stringency likely to cause a conflict with our rollover resistance objectives.

As to another concern we identified in the NPRM, the possibility that some kinds of State tort laws requiring improved roof crush resistance might cause a diversion of resources away from manufacturer efforts to use advanced technologies to reduce rollovers, we have concluded that it is not possible to identify how such resources would otherwise have been used. Specifically, there is not a basis to conclude that such resources would otherwise have been used for improving rollover resistance or improving safety. Therefore, we believe that such tort laws do not create a conflict on these grounds.

Finally, as noted earlier, vehicle manufacturers suggested that we consider a potential policy conflict in the area of vehicle compatibility. They stated that the addition of weight would increase the chances of vehicle mass mismatch in a collision. However, mass mismatch is only one key aspect of vehicle-to-vehicle crash compatibility, particularly in frontal crashes. Vehicle stiffness and geometric alignment are also important factors in vehicle compatibility. While it is hypothetically possible that some kinds of tort laws on roof strength could contribute toward greater differential in weight between some vehicles, e.g., if they resulted in manufacturers adding significant weight to heavier vehicles, we believe it is not possible to define any level of stringency of roof crush resistance above which tort laws would create a conflict with our vehicle compatibility objectives. We note that in redesigning vehicles in ways that improve roof strength and also minimize impacts on vehicle mass, manufacturers have many design options to avoid or minimize adding weight (e.g., use of advanced light materials in various parts of the vehicle, including ones other than those related to the roof). There may also be ways of offsetting any possible incremental change in fleet compatibility due to increased weight mismatch that might occur with vehicle geometric and/or stiffness design

⁴⁹ See, e.g., *Hillsborough County v. Automated Medical Laboratories, Inc.*, 471 U.S. 707, 718 (1985); *Medtronic, Inc., v. Lohr*, 518 U.S. 470, 506 (1996) (Justice Breyer, in concurrence); and *Geier v. American Honda Motor Co.*, 529 U.S. 861, 908 (2000) (Justice Stevens, in dissent).

⁴⁸ 2002 and 2007 Toyota Camry; 2003 and 2007 Toyota Tacoma; 2004 and 2008 Honda Accord.

modifications. We note that the vehicle manufacturers did not provide technical analysis addressing the latter issue.

Therefore, although under the principles enunciated in *Geier* it is possible that a rule of State tort law could conflict with a NHTSA safety standard if it created an obstacle to the accomplishment and execution of that standard, we do not currently foresee the likelihood of any such tort requirements and do not have a basis for concluding that any particular levels of stringency would create such a conflict.

d. Unfunded Mandates Reform Act

The Unfunded Mandates Reform Act of 1995 (UMRA) requires Federal agencies to prepare a written assessment of the costs, benefits and other effects of proposed or final rules that include a Federal mandate likely to result in the expenditure by State, local or tribal governments, in the aggregate, or by the private sector, of more than \$100 million annually (adjusted annually for inflation, with base year of 1995). These effects are discussed earlier in this preamble and in the FRIA. UMRA also requires an agency issuing a final rule subject to the Act to select the "least costly, most cost-effective or least burdensome alternative that achieves the objectives of the rule."

The preamble and the FRIA identify and consider a number of alternatives, concerning factors such as single- or two-sided test requirements, different SWR levels, and phase-in schedule. Alternatives considered by and rejected by us would not fully achieve the objectives of the alternative preferred by NHTSA (a reasonable balance between the benefits and costs). The agency believes that it has selected the most cost-effective alternative that achieves the objectives of the rulemaking.

e. National Environmental Policy Act

NHTSA has analyzed this final rule for the purposes of the National Environmental Policy Act. The agency has determined that implementation of this action will not have any significant impact on the quality of the human environment.

f. Executive Order 12778 (Civil Justice Reform)

With respect to the review of the promulgation of a new regulation, section 3(b) of Executive Order 12988, "Civil Justice Reform" (61 FR 4729, February 7, 1996) requires that Executive agencies make every reasonable effort to ensure that the regulation: (1) Clearly specifies the preemptive effect; (2) clearly specifies the effect on existing Federal law or

regulation; (3) provides a clear legal standard for affected conduct, while promoting simplification and burden reduction; (4) clearly specifies the retroactive effect, if any; (5) adequately defines key terms; and (6) addresses other important issues affecting clarity and general draftsmanship under any guidelines issued by the Attorney General. This document is consistent with that requirement.

Pursuant to this Order, NHTSA notes as follows. The preemptive effect of this rule is discussed above. NHTSA notes further that there is no requirement that individuals submit a petition for reconsideration or pursue other administrative proceeding before they may file suit in court.

g. Plain Language

Executive Order 12866 requires each agency to write all rules in plain language. Application of the principles of plain language includes consideration of the following questions:

- Have we organized the material to suit the public's needs?
- Are the requirements in the rule clearly stated?
- Does the rule contain technical language or jargon that isn't clear?
- Would a different format (grouping and order of sections, use of headings, paragraphing) make the rule easier to understand?
- Would more (but shorter) sections be better?
- Could we improve clarity by adding tables, lists, or diagrams?
- What else could we do to make the rule easier to understand?

If you have any responses to these questions, please write to us with your views.

h. Paperwork Reduction Act (PRA)

Under the PRA of 1995, a person is not required to respond to a collection of information by a Federal agency unless the collection displays a valid OMB control number. The final rule contains a collection of information because of the proposed phase-in reporting requirements. There is no burden to the general public.

The collection of information requires manufacturers of passenger cars and multipurpose passenger vehicles, trucks and buses with a GVWR of 2,722 kilograms (6,000 pounds) or less to annually submit a report, and maintain records related to the report, concerning the number of such vehicles that meet the upgraded roof strength requirements. The phase-in will cover three years. The purpose of the reporting and recordkeeping requirements is to assist the agency in

determining whether a manufacturer of vehicles has complied with the requirements during the phase-in period.

We will submit a request for OMB clearance of the collection of information required under today's final rule in time to obtain clearance prior to the beginning of the phase-in at the beginning of September 2012.

These requirements and our estimates of the burden to vehicle manufacturers are as follows:

NHTSA estimates that there are 21 manufacturers of passenger cars, multipurpose passenger vehicles, trucks, and buses with a GVWR of 2,722 kilograms (6,000 pounds) or less;

NHTSA estimates that the total annual reporting and recordkeeping burden resulting from the collection of information is 1,260 hours;

NHTSA estimates that the total annual cost burden, in U.S. dollars, will be \$0. No additional resources will be expended by vehicle manufacturers to gather annual production information because they already compile this data for their own use.

A **Federal Register** document must provide a 60-day comment period concerning the collection of information. The Office of Management and Budget (OMB) promulgated regulations describing what must be included in such a document. Under OMB's regulations (5 CFR 320.8(d)), agencies must ask for public comment on the following:

(1) Whether the collection of information is necessary for the proper performance of the functions of the agency, including whether the information will have practical utility;

(2) The accuracy of the agency's estimate of the burden of the proposed collection of information, including the validity of the methodology and assumptions used;

(3) How to enhance the quality, utility, and clarity of the information to be collected; and,

(4) How to minimize the burden of the collection of information on those who are to respond, including the use of appropriate automated, electronic, mechanical, or other technological collection techniques or other forms of information technology, e.g., permitting electronic submission of responses.

i. National Technology Transfer and Advancement Act

Under the National Technology Transfer and Advancement Act of 1995 (NTTAA) (Pub. L. 104-113),

All Federal agencies and departments shall use technical standards that are developed or adopted by voluntary consensus standards

bodies, using such technical standards as a means to carry out policy objectives or activities determined by the agencies and departments.

Voluntary consensus standards are technical standards (e.g., materials specifications, test methods, sampling procedures, and business practices) that are developed or adopted by voluntary consensus standards bodies, such as the International Organization for Standardization (ISO) and the Society of Automotive Engineers (SAE). The NHTAA directs us to provide Congress, through OMB, explanations when we decide not to use available and applicable voluntary consensus standards.

We are incorporating the voluntary consensus standard SAE Standard J826 "Devices for Use in Defining and Measuring Vehicle Seating Accommodation," SAE J826 (rev. July 1995) into the requirements of FMVSS No. 216a as part of this rulemaking. As discussed in the NPRM, we evaluated the SAE inverted drop testing procedure, but decided against proposing it.

List of Subjects

49 CFR Part 571

Imports, Incorporation by reference, Motor vehicle safety, Reporting and recordkeeping requirements, Tires.

49 CFR Part 585

Motor vehicle safety, Reporting and recordkeeping requirements.

■ In consideration of the foregoing, NHTSA amends 49 CFR Chapter V as set forth below.

PART 571—FEDERAL MOTOR VEHICLE SAFETY STANDARDS

■ 1. The authority citation for part 571 of title 49 continues to read as follows:

Authority: 49 U.S.C. 322, 30111, 30115, 30117, and 30166; delegation of authority at 49 CFR 1.50.

■ 2. Section 571.216 is amended by revising the section heading and S3 to read as follows:

§ 571.216 Standard No. 216; Roof crush resistance; Applicable unless a vehicle is certified to § 571.216a.

* * * * *

S3. Application.

(a) This standard applies to passenger cars, and to multipurpose passenger vehicles, trucks and buses with a GVWR of 2,722 kilograms (6,000 pounds) or less. However, it does not apply to—

(a) School buses;

(b) Vehicles that conform to the rollover test requirements (S5.3) of

Standard No. 208 (§ 571.208) by means that require no action by vehicle occupants;

(c) Convertibles, except for optional compliance with the standard as an alternative to the rollover test requirements in S5.3 of Standard No. 208; or

(d) Vehicles certified to comply with § 571.216a.

* * * * *

■ 3. Section 571.216a is added to read as follows:

§ 571.216a Standard No. 216a; Roof crush resistance; Upgraded standard.

S1. *Scope.* This standard establishes strength requirements for the passenger compartment roof.

S2. *Purpose.* The purpose of this standard is to reduce deaths and injuries due to the crushing of the roof into the occupant compartment in rollover crashes.

S3. *Application, incorporation by reference, and selection of compliance options.*

S3.1 Application.

(a) This standard applies to passenger cars, and to multipurpose passenger vehicles, trucks and buses with a GVWR of 4,536 kilograms (10,000 pounds) or less, according to the implementation schedule specified in S8 and S9 of this section. However, it does not apply to—

(1) School buses;

(2) Vehicles that conform to the rollover test requirements (S5.3) of Standard No. 208 (§ 571.208) by means that require no action by vehicle occupants;

(3) Convertibles, except for optional compliance with the standard as an alternative to the rollover test requirement (S5.3) of Standard No. 208; or

(4) Trucks built in two or more stages with a GVWR greater than 2,722 kilograms (6,000 pounds) not built using a chassis cab.

(b) At the option of the manufacturer, vehicles within either of the following categories may comply with the roof crush requirements (S4) of Standard No. 220 (§ 571.220) instead of the requirements of this standard:

(1) Vehicles built in two or more stages, other than vehicles built using a chassis cab;

(2) Vehicles with a GVWR greater than 2,722 kilograms (6,000 pounds) that have an altered roof as defined by S4 of this section.

(c) Manufacturers may comply with the standard in this § 571.216a as an alternative to § 571.216.

S3.2 *Incorporation by reference.* Society of Automotive Engineers (SAE) Standard J826 "Devices for Use in

Defining and Measuring Vehicle Seating Accommodation," SAE J826 (rev. July 1995) is incorporated by reference in S7.2 of this section. The Director of the Federal Register has approved the incorporation by reference of this material in accordance with 5 U.S.C. 552(a) and 1 CFR part 51. A copy of SAE J826 (rev. Jul 95) may be obtained from SAE at the Society of Automotive Engineers, Inc., 400 Commonwealth Drive, Warrendale, PA 15096. *Phone:* 1-724-776-4841; *Web:* <http://www.sae.org>. A copy of SAE J826 (July 1995) may be inspected at NHTSA's Technical Information Services, 1200 New Jersey Avenue, Washington, DC 20590, or at the National Archives and Records Administration (NARA). For information on the availability of this material at NARA, call 202-741-6030, or go to: http://www.archives.gov/federal_register/code_of_federal_regulations/ibr_locations.html.

S3.3 Selection of compliance option.

Where manufacturer options are specified, the manufacturer shall select the option by the time it certifies the vehicle and may not thereafter select a different option for the vehicle. Each manufacturer shall, upon the request from the National Highway Traffic Safety Administration, provide information regarding which of the compliance options it selected for a particular vehicle or make/model.

S4. Definitions.

Altered roof means the replacement roof on a motor vehicle whose original roof has been removed, in part or in total, and replaced by a roof that is higher than the original roof. The replacement roof on a motor vehicle whose original roof has been replaced, in whole or in part, by a roof that consists of glazing materials, such as those in T-tops and sunroofs, and is located at the level of the original roof, is not considered to be an altered roof.

Convertible means a vehicle whose A-pillars are not joined with the B-pillars (or rearmost pillars) by a fixed, rigid structural member.

S5. Requirements.

S5.1 When the test device described in S6 is used to apply a force to a vehicle's roof in accordance with S7, first to one side of the roof and then to the other side of the roof:

(a) The lower surface of the test device must not move more than 127 millimeters, and

(b) No load greater than 222 Newtons (50 pounds) may be applied to the head form specified in S5.2 of 49 CFR 571.201 located at the head position of a 50th percentile adult male in accordance with S7.2 of this section.

S5.2 The maximum applied force to the vehicle's roof in Newtons is:

(a) For vehicles with a GVWR of 2,722 kilograms (6,000 pounds) or less, any value up to and including 3.0 times the unloaded vehicle weight of the vehicle, measured in kilograms and multiplied by 9.8, and

(b) For vehicles with a GVWR greater than 2,722 kilograms (6,000 pounds), any value up to and including 1.5 times the unloaded vehicle weight of the vehicle, measured in kilograms and multiplied by 9.8.

S6. *Test device.* The test device is a rigid unyielding block whose lower surface is a flat rectangle measuring 762 millimeters by 1,829 millimeters.

S7. *Test procedure.* Each vehicle must be capable of meeting the requirements of S5 when tested in accordance with the procedure in S7.1 through S7.6.

S7.1 Support the vehicle off its suspension and rigidly secure the sills and the chassis frame (when applicable) of the vehicle on a rigid horizontal surface(s) at a longitudinal attitude of 0 degrees \pm 0.5 degrees. Measure the longitudinal vehicle attitude along both the driver and passenger sill. Determine the lateral vehicle attitude by measuring the vertical distance between a level surface and a standard reference point on the bottom of the driver and passenger side sills. The difference between the vertical distance measured on the driver side and the passenger side sills is not more than \pm 10 mm. Close all windows, close and lock all doors, and close and secure any moveable roof panel, moveable shade, or removable roof structure in place over the occupant compartment. Remove roof racks or other non-structural components. For a vehicle built on a chassis-cab incomplete vehicle that has some portion of the added body structure above the height of the incomplete vehicle, remove the entire added body structure prior to testing (the vehicle's unloaded vehicle weight as specified in S5 includes the weight of the added body structure).

S7.2 Adjust the seats in accordance with S8.3 of 49 CFR 571.214. Position the top center of the head form specified in S5.2 of 49 CFR 571.201 at the location of the top center of the Head Restraint Measurement Device (HRMD) specified in 49 CFR 571.202a, in the front outboard designated seating position on the side of the vehicle being tested as follows:

(a) Position the three dimensional manikin specified in Society of Automotive Engineers (SAE) Surface Vehicle Standard J826, revised July 1995, "Devices for Use in Defining and Measuring Vehicle Seating

Accommodation," (incorporated by reference, see paragraph S3.2), in accordance to the seating procedure specified in that document, except that the length of the lower leg and thigh segments of the H-point machine are adjusted to 414 and 401 millimeters, respectively, instead of the 50th percentile values specified in Table 1 of SAE J826 (July 1995).

(b) Remove four torso weights from the three-dimensional manikin specified in SAE J826 (July 1995) (two from the left side and two from the right side), replace with two HRMD torso weights (one on each side), and attach and level the HRMD head form.

(c) Mark the location of the top center of the HRMD in three dimensional space to locate the top center of the head form specified in S5.2 of 49 CFR 571.201.

S7.3 Orient the test device as shown in Figure 1 of this section, so that—

(a) Its longitudinal axis is at a forward angle (in side view) of 5 degrees (\pm 0.5 degrees) below the horizontal, and is parallel to the vertical plane through the vehicle's longitudinal centerline;

(b) Its transverse axis is at an outboard angle, in the front view projection, of 25 degrees below the horizontal (\pm 0.5 degrees).

S7.4 Maintaining the orientation specified in S7.3 of this section—

(a) Lower the test device until it initially makes contact with the roof of the vehicle.

(b) Position the test device so that—

(1) The longitudinal centerline on its lower surface is within 10 mm of the initial point of contact, or on the center of the initial contact area, with the roof; and

(2) The midpoint of the forward edge of the lower surface of the test device is within 10 mm of the transverse vertical plane 254 mm forward of the forwardmost point on the exterior surface of the roof, including windshield trim, that lies in the longitudinal vertical plane passing through the vehicle's longitudinal centerline.

S7.5 Apply force so that the test device moves in a downward direction perpendicular to the lower surface of the test device at a rate of not more than 13 millimeters per second until reaching the force level specified in S5. Guide the test device so that throughout the test it moves, without rotation, in a straight line with its lower surface oriented as specified in S7.3(a) and S7.3(b). Complete the test within 120 seconds.

S7.6 Repeat the test on the other side of the vehicle.

S8. *Phase-in schedule for vehicles with a GVWR of 2,722 kilograms (6,000 pounds) or less.*

S8.1 *Vehicles manufactured on or after September 1, 2012, and before September 1, 2013.* For vehicles manufactured on or after September 1, 2012, and before September 1, 2013, the number of vehicles complying with this standard must not be less than 25 percent of:

(a) The manufacturer's average annual production of vehicles manufactured on or after September 1, 2009, and before September 1, 2012; or

(b) The manufacturer's production on or after September 1, 2012, and before September 1, 2013.

S8.2 *Vehicles manufactured on or after September 1, 2013, and before September 1, 2014.* For vehicles manufactured on or after September 1, 2013, and before September 1, 2014, the number of vehicles complying with this standard must not be less than 50 percent of:

(a) The manufacturer's average annual production of vehicles manufactured on or after September 1, 2010, and before September 1, 2013; or

(b) The manufacturer's production on or after September 1, 2013, and before September 1, 2014.

S8.3 *Vehicles manufactured on or after September 1, 2014, and before September 1, 2015.* For vehicles manufactured on or after September 1, 2014, and before September 1, 2015, the number of vehicles complying with this standard must not be less than 75 percent of:

(a) The manufacturer's average annual production of vehicles manufactured on or after September 1, 2011, and before September 1, 2014; or

(b) The manufacturer's production on or after September 1, 2014, and before September 1, 2015.

S8.4 *Vehicles manufactured on or after September 1, 2015.* Except as provided in S8.8, each vehicle manufactured on or after September 1, 2015 must comply with this standard.

S8.5 *Calculation of complying vehicles.*

(a) For purpose of complying with S8.1, a manufacturer may count a vehicle if it is certified as complying with this standard and is manufactured on or after September 1, 2012, but before September 1, 2013.

(b) For purposes of complying with S8.2, a manufacturer may count a vehicle if it:

(1) Is certified as complying with this standard and is manufactured on or after September 1, 2012, but before September 1, 2014; and

(2) Is not counted toward compliance with S8.1.

(c) For purposes of complying with S8.3, a manufacturer may count a vehicle if it:

(1) Is certified as complying with this standard and is manufactured on or after September 1, 2012, but before September 1, 2015; and

(2) Is not counted toward compliance with S8.1 or S8.2.

S8.6 Vehicles produced by more than one manufacturer.

S8.6.1 For the purpose of calculating average annual production of vehicles for each manufacturer and the number of vehicles manufactured by each manufacturer under S8.1 through S8.3, a vehicle produced by more than one manufacturer must be attributed to a single manufacturer as follows, subject to S8.6.2:

(a) A vehicle that is imported must be attributed to the importer.

(b) A vehicle manufactured in the United States by more than one manufacturer, one of which also markets the vehicle, must be attributed

to the manufacturer that markets the vehicle.

S8.6.2 A vehicle produced by more than one manufacturer must be attributed to any one of the vehicle's manufacturers specified by an express written contract, reported to the National Highway Traffic Safety Administration under 49 CFR Part 585, between the manufacturer so specified and the manufacturer to which the vehicle would otherwise be attributed under S8.6.1.

S8.7 Small volume manufacturers.

Vehicles manufactured during any of the three years of the September 1, 2012 through August 31, 2015 phase-in by a manufacturer that produces fewer than 5,000 vehicles for sale in the United States during that year are not subject to the requirements of S8.1, S8.2, and S8.3.

S8.8 Final-stage manufacturers and alterers.

Vehicles that are manufactured in two or more stages or that are altered (within

the meaning of 49 CFR 567.7) after having previously been certified in accordance with Part 567 of this chapter are not subject to the requirements of S8.1 through S8.3. Instead, all vehicles produced by these manufacturers on or after September 1, 2016 must comply with this standard.

S9 Vehicles with a GVWR above 2,722 kilograms (6,000 pounds).

(a) Except as provided in S9(b), each vehicle manufactured on or after September 1, 2016 must comply with this standard.

(b) Vehicles that are manufactured in two or more stages or that are altered (within the meaning of 49 CFR 567.7) after having previously been certified in accordance with Part 567 of this chapter are not subject to the requirements of S8.1 through S8.3. Instead, all vehicles produced by these manufacturers on or after September 1, 2017 must comply with this standard.

BILLING CODE P

Figure 1 to § 571.216

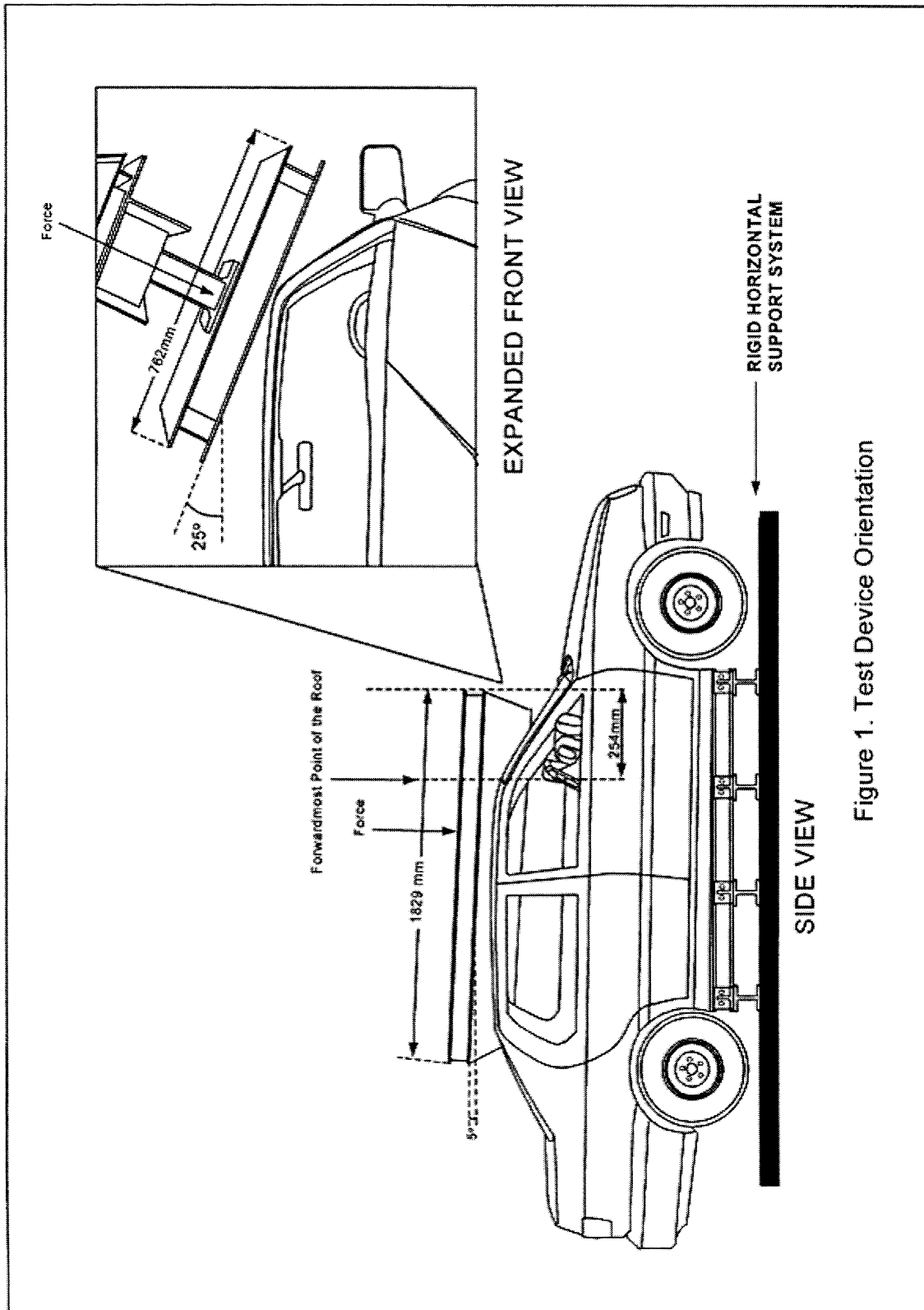

Figure 1. Test Device Orientation

■ 6. The authority citation for Part 585 continues to read as follows:

Authority: 49 U.S.C. 322, 30111, 30115, 30117, and 30166; delegation of authority at 49 CFR 1.50.

PART 585—[AMENDED]

■ 7. Part 585 is amended by adding Subpart L to read as follows:

Subpart L—Roof Crush Resistance Phase-in Reporting Requirements

Sec.	
585.111	Scope.
585.112	Purpose.
585.113	Applicability.
585.114	Definitions.
585.115	Response to inquiries.
585.116	Reporting requirements.
585.117	Records.

Subpart L—Roof Crush Resistance Phase-in Reporting Requirements**§ 585.111 Scope.**

This subpart establishes requirements for manufacturers of passenger cars, multipurpose passenger vehicles, trucks, and buses with a gross vehicle weight rating of 2,722 kilograms (6,000 pounds) or less to submit a report, and maintain records related to the report, concerning the number of such vehicles that meet the requirements of Standard No. 216a; *Roof crush resistance; Upgraded standard* (49 CFR 571.216a).

§ 585.112 Purpose.

The purpose of these reporting requirements is to assist the National Highway Traffic Safety Administration in determining whether a manufacturer has complied with Standard No. 216a (49 CFR 571.216a).

§ 585.113 Applicability.

This subpart applies to manufacturers of passenger cars, multipurpose passenger vehicles, trucks, and buses with a gross vehicle weight rating of 2,722 kilograms (6,000 pounds) or less. However, this subpart does not apply to manufacturers whose production consists exclusively of vehicles manufactured in two or more stages, and vehicles that are altered after previously having been certified in accordance with part 567 of this chapter. In addition, this subpart does not apply to manufacturers whose production of motor vehicles for the United States market is less than 5,000 vehicles in a production year.

§ 585.114 Definitions.

For the purposes of this subpart: *Production year* means the 12-month period between September 1 of one year and August 31 of the following year, inclusive.

§ 585.115 Response to inquiries.

At any time prior to August 31, 2018, each manufacturer must, upon request from the Office of Vehicle Safety Compliance, provide information identifying the vehicles (by make, model, and vehicle identification number) that have been certified as complying with Standard No. 216a (49 CFR 571.216a). The manufacturer's

designation of a vehicle as a certified vehicle is irrevocable. Upon request, the manufacturer also must specify whether it intends to utilize carry-forward credits, and the vehicles to which those credits relate.

§ 585.116 Reporting requirements.

(a) *General reporting requirements.* Within 60 days after the end of the production years ending August 31, 2013, August 31, 2014, and August 31, 2015, each manufacturer must submit a report to the National Highway Traffic Safety Administration concerning its compliance with Standard No. 216a (49 CFR 571.216a) for its passenger cars, multipurpose passenger vehicles, trucks, and buses with a gross vehicle weight rating of less than 2,722 kilograms (6,000 pounds) produced in that year. Each report must —

- (1) Identify the manufacturer;
- (2) State the full name, title, and address of the official responsible for preparing the report;
- (3) Identify the production year being reported on;
- (4) Contain a statement regarding whether or not the manufacturer complied with the requirements of Standard No. 216a (49 CFR 571.216a) for the period covered by the report and the basis for that statement;
- (5) Provide the information specified in paragraph (b) of this section;
- (6) Be written in the English language; and
- (7) Be submitted to: Administrator, National Highway Traffic Safety Administration, 1200 New Jersey Avenue, SE., Washington, DC 20590.

(b) *Report content—(1) Basis for statement of compliance.* Each manufacturer must provide the number of passenger cars, multipurpose passenger vehicles, trucks, and buses with a gross vehicle weight rating of 2,722 kilograms (6,000 pounds) or less, manufactured for sale in the United States for each of the three previous production years, or, at the manufacturer's option, for the current production year. A new manufacturer that has not previously manufactured these vehicles for sale in the United States must report the number of such vehicles manufactured during the current production year.

(2) *Production.* Each manufacturer must report for the production year for which the report is filed: the number of passenger cars, multipurpose passenger vehicles, trucks, and buses with a gross vehicle weight rating of 2,722 kilograms (6,000 pounds) or less that meet Standard No. 216a (49 CFR 571.216a).

(3) *Statement regarding compliance.* Each manufacturer must provide a

statement regarding whether or not the manufacturer complied with the requirements of Standard No. 216a (49 CFR 571.216a) as applicable to the period covered by the report, and the basis for that statement. This statement must include an explanation concerning the use of any carry-forward credits.

(4) *Vehicles produced by more than one manufacturer.* Each manufacturer whose reporting of information is affected by one or more of the express written contracts permitted by S8.6.2 of Standard No. 216a (49 CFR 571.216a) must:

(i) Report the existence of each contract, including the names of all parties to the contract, and explain how the contract affects the report being submitted.

(ii) Report the actual number of vehicles covered by each contract.

§ 585.117 Records.

Each manufacturer must maintain records of the Vehicle Identification Number for each vehicle for which information is reported under § 585.116(b)(2) until December 31, 2018.

Issued on: April 30, 2009.

Ronald L. Medford,
Acting Deputy Administrator.

Appendix A—Analysis of Comments Concerning Dynamic Testing

NHTSA did not propose a dynamic test procedure in the NPRM or the SNPRM. However, in the NPRM, we discussed comments received in response to our October 2001 RFC concerning whether we should include some type of dynamic test as part of the roof crush resistance standard. We discussed several types of dynamic tests, including the inverted drop test, the FMVSS No. 208 dolly test, the Controlled Rollover Impact System (CRIS) test, and the Jordan Rollover System (JRS) test. We identified a number of concerns about using these tests in FMVSS No. 216. We noted our belief that the current quasi-static test procedure is repeatable and capable of simulating real-world rollover deformation patterns. We also stated that we were unaware of any dynamic test procedures that provide a sufficiently repeatable test environment.

Several consumer advocacy organizations and a number of other commenters argued that the agency should propose a dynamic test procedure in lieu of the proposed quasi-static test. Ms. Lawlor and Mr. Clough suggested a dynamic rollover test is more reflective of real-world rollovers. Boyle et al. suggested that a dynamic test would provide the most accurate data for regulation. Mr. Turner recommended that such a test would better measure the comprehensive interaction among safety systems in a rollover crash. Mr. Friedman and the Center for Injury Research (CFIR) recommended the use of the JRS or a modified FMVSS No. 208 dolly rollover test. Mr. Friedman further stated that when given the chance, engineers design the structure to

deal with the dynamic impact realities required to protect occupants and not to meet what he characterized as a vaguely related criteria like SWR.

DVExperts asserted that a static test, such as FMVSS No. 216 or any variation on this, is not an effective rollover performance test, just as a load test would be considered defective for frontal or side impacts. Public Citizen recommended a dynamic test because it can be improved to better simulate a rollover. It believes a static test is inappropriate for a roof crush test.

Advocates stated that a dynamic test would show how to model occupant injury mechanisms and their prevention to provide substantially enhanced roof crush resistance. Both Advocates and Public Citizen recommended the development of a biofidelic rollover anthropomorphic test device (ATD) to measure forces accurately in a dynamic test. Syson stated that although some aspects of real rollover crashes are not representative in dynamic tests, useful engineering information can be obtained from the results. Syson also expressed concern with including a dummy in dynamic testing because biofidelic problems may help obscure the consequences of roof failure or safety belt performance.

As indicated above, some of the commenters recommending a dynamic test cited potential benefits related to aspects of performance other than roof crush resistance, e.g., measuring the performance of seat belts, doors, ejection. We note that the suitability of a particular dynamic test must be assessed separately for each aspect of performance that would be addressed. In this rulemaking, we are addressing roof crush resistance, and our discussion and analysis of the comments focus on that issue. Our discussion and analysis below in some instances cite potential problems related to measuring other aspects of performance which might be measured during a test that evaluates roof crush resistance. However, we emphasize that our discussion/analysis does not in any way represent an assessment by the agency as to whether any of the tests would be suitable for addressing aspects of performance other than roof crush resistance.

FMVSS No. 208 Dolly Rollover Test

Section 5.3 of FMVSS No. 208 contains a dynamic test commonly known as the "dolly rollover test." This test was part of early provisions in FMVSS No. 208 which permitted manufacturers the option of providing automatic crash protection in lateral and rollover crashes instead of seat belts. We believe that no manufacturer ever selected the option for purposes of complying with FMVSS No. 208. Selection of the option was ultimately precluded by the Intermodal Surface Transportation Efficiency Act of 1991, which required the installation of lap/shoulder belts. FMVSS No. 216 has long contained a provision that excludes vehicles that conform to the S5.3 rollover test requirements of FMVSS No. 208 by means that require no action by vehicle occupants. We are unaware of any vehicle that has been certified to S5.3 in lieu of FMVSS No. 216.

As discussed in our August 2005 NPRM, the FMVSS No. 208 dolly test was originally

developed only as an occupant containment test and not to evaluate the loads on specified vehicle components. While S5.3 of FMVSS No. 208 specifies that an unbelted Hybrid III 50th percentile adult male dummy must be retained inside the vehicle during the test, it does not specify roof strength performance criteria or injury assessment reference values that must be met. We stated in the NPRM that we believed that this test lacks sufficient repeatability to serve as a structural component compliance requirement.

A number of commenters recommended that the agency propose a dolly rollover test. Advocates, Bidez & Associates (Bidez), SRS, Public Citizen, CFIR and Mr. Friedman cited use of the dolly rollover test in the Volvo XC90 development program. Several commenters stated that the dolly rollover test remains an option for certification in lieu of FMVSS No. 216.

Advocates and Bidez disagreed with the agency's statement that the dolly rollover test is not sufficiently repeatable. Bidez presented data from three dolly rollover tests conducted for Ford at the Autoliv Test Center to support its position. Bidez concluded that the test was repeatable based on the timing similarities of the peak neck forces and moments.

Ford submitted additional comments refuting Bidez's conclusions and claimed the wide range of amplitude and timing for the occupant injury measures were not repeatable.

CFIR also stated that dynamic rollover tests have been widely used to qualify safety devices. It stated they are repeatable in that the initial conditions are highly controlled, and it stated that a vehicle designed to pass can do so repeatedly. CFIR also acknowledged, however, that dolly rollover tests do not reproduce the same initial roof-to-ground contact conditions and small changes can cause large differences in vehicle trajectory and dummy kinematics.

In support of a dynamic test such as the dolly test, Technical Services commented that while dolly rollover tests do not produce occupant kinematics that are representative of highway rollovers, they represent a more difficult test for the vehicle because of the lateral component.

Agency Response

While the FMVSS No. 208 dolly rollover test has long been an option for manufacturers in lieu of the FMVSS No. 216 test, it is an option that they have never used. Thus, there has not been any experience with using that test for purposes of compliance with an FMVSS.

Moreover, as noted above, the test was not developed to evaluate the loads on specified vehicle components. While S5.3 of FMVSS No. 208 specifies that an unbelted Hybrid III 50th percentile adult male dummy be retained inside the vehicle, it does not specify roof strength performance criteria or injury assessment reference values that must be met.

Some commenters stated the dolly test was used in the development of the Volvo XC90 and is therefore an accepted industry practice. We note, however, that there is a significant difference between vehicle development work by manufacturers and

objective test procedures needed for a FMVSS.

No commenters provided data demonstrating that the agency's concerns about the dolly test lacking sufficient repeatability to serve as a vehicle structural component compliance requirement for assessing roof strength are unfounded. We note that our research is consistent with the comments from CFIR concerning reproducibility problems with respect to initial roof to ground contact conditions. We believe that reproducibility in that area would be an important issue for measurement of roof intrusion in an FMVSS.

In response to Bidez, we agree that the "timing" of peak axial neck force was similar in their submitted test data; however, we also noted that the magnitudes of the neck forces varied considerably (from 260 N to 5,933 N) for the passenger side dummy of a driver side leading test. Further, the moments and forces for the driver side dummy also experienced wide ranges in values despite the similar timing of the event. Given the wide range of reported peak loads and moments, we are not convinced that repeatable timing is more important than repeatable peak values in the injury measurements.

The Bidez test data further showed the variation in the range of post-test headroom for these three dolly rollover tests. In two tests, the driver post test headroom increased 212 mm and 444 mm (8.3 inches and 15.5 inches), but in the third test, it decreased 31 mm (-5.9 inches). The passenger side showed similar results. It should also be noted that the measured headroom difference between the driver's and passenger's side in each test were relatively similar. This suggested that the roof deformed equally on both sides but the amount of deformation differed from test to test. These results suggest that the current dolly rollover test is not repeatable as a roof crush test.

As stated in the NPRM, the agency has conducted prior dolly testing (similar to the FMVSS No. 208 dolly rollover test) and determined that the test conditions were so severe that it was difficult to identify which vehicles had better performing roofs. Based on these, and other dynamic tests, the agency decided that it was best to pursue an upgraded quasi-static test for this rulemaking.

Jordan Rollover System (JRS)

There were a range of comments related to the Jordan Rollover System (JRS) test. The JRS device rotates a vehicle body structure on a rotating apparatus ("spit") while the road surface platform moves a track underneath the vehicle and contacts the roof structure. Comments on the JRS were submitted by the following groups: Advocates, CFIR, DVExperts, Xprts, and Public Citizen. Some commenters recommended developing a safety standard using the test procedure, while others recommended that the agency undertake a research program and investigate the JRS fully.

Advocates recommended using the JRS procedure. CFIR provided information concerning the JRS test procedure and addressing repeatability of the initial conditions, including data from their JRS

research program. DVExperts claimed the JRS is a repeatable, practical, and scientifically valid dynamic rollover test procedure. Xprts submitted summary results from JRS testing of a Jeep Grand Cherokee. It identified roof intrusion velocities and roof deformation behavior (buckling) as important criteria for determining injury. Public Citizen commented that NHTSA should thoroughly investigate the JRS. Public Citizen and CFIR also commented that the JRS test can be conducted with dummies that demonstrate whether vehicle roof performance meets objective injury and ejection criteria for belted and unbelted occupants.

CFIR also recommended a maximum axial neck load injury measurement (Fz) of 7,000 N⁵⁰ (1,574 pounds) using the Hybrid III dummy in the JRS. The recommendation was based on cadaver and dummy drop and impact tests. CFIR also acknowledged that the Hybrid III dummy has poor biofidelity in the rollover mode. As an alternative, it recommended using the roof velocity and intrusion amplitude, as measured by an array of string potentiometers attached to the roof. The criteria were based on its axial neck load research. CFIR claimed to have found a good correlation between neck injury and the speed of head impact.

In response to the SNPRM, CAS and CFIR submitted additional instrumented test data using the JRS⁵¹ equipped with a Hybrid III dummy. The test vehicles were selected from the agency's fleet evaluation. They argued, based upon the data, the JRS is highly controlled and repeatable. They further suggested that the equipment, and the test costs are modest. The test conditions can be widely varied to emulate actual rollover conditions.

Mr. Nash provided an analysis of NASS rollover cases. He concluded that the FMVSS No. 216 platen test would not stress the windshield header and create the type of buckling shown in the NASS cases. Mr. Nash claimed that the dynamic JRS test would identify the header deformation.

Agency Response

While a number of commenters indicated support for the JRS dynamic test procedure, and the developers submitted data for multiple tests, the agency has remaining questions regarding the setup, conduct, and evaluation of the JRS test procedure despite witnessing the JRS testing in February 2007 and multiple other meetings. All commenters relied on the JRS tests conducted and reported by CFIR and Xprts.

After considering the data submitted, we believe there are a large number of unresolved technical issues related to the JRS with respect to whether it would be suitable as a potential test procedure to replicate real-world crash damage patterns for a safety standard evaluating vehicle roof crush structural integrity. These include:

Test Parameters

- *Determination of the drop height (for different vehicles)*—The JRS releases the test vehicle from a predetermined drop height to fall onto a moving roadway. The ideal drop height is not known. If the drop height is not correlated with real world data, some vehicles could be overloaded beyond what would be representative of real world crashes. Other vehicles could be under-exercised based on accident conditions. A specific drop height or drop height methodology would need to be sensitive to the vehicle types and crash conditions in the fleet.

- *Determination of the roll rate and roll angle at vehicle release (for different vehicles)*—The JRS releases the test vehicle at a predetermined roll rate. The roll rate, drop height, and angle at which the vehicle is released are carefully coordinated to obtain an initial contact between the vehicle and the moving roadway at the nearside A-pillar/roof junction. While advocates of the test present anecdotal support for the test conditions, the appropriateness of the specific test conditions is not clear. There may be many vehicles that miss contacting the near side A-pillar/roof junction and have first contact with the far side of the roof. Roll rate has a role in the duration of the load on the roof and could have a significant effect on the roof performance during the test. If the roll rate is too slow, intrusion could be minimal. If the roll rate is too fast, intrusion could be excessive. We believe there is a need to correlate these parameters to real world data, which we do not have.

- *Determination of the roadway speed and road surface*—The JRS drops the vehicle onto an instrumented moving roadway that is covered with sandpaper to represent the vehicle-to-ground interaction. The roadway speed and the vehicle-to-ground friction play a significant role in controlling the transfer of momentum between the rotating vehicle and the moving roadway. Changing the roadway speed may affect how the vehicle interacts with the ground for the far side contact. Research would be necessary to understand this interaction and how the initial contact conditions affect the JRS test kinematics.

- *Repeatability of the drop height, roll rate, release angle, initial contact with the roadway and roadway speed*—Any regulatory test needs to be repeatable and enforceable. The agency does not have any experience with the JRS to know what its operating tolerances are. If it is possible to first determine optimum or representative conditions, it is then necessary to determine the accuracy and repeatability that a test device can provide for those conditions using a wide variety of vehicle sizes and shapes. For example, there are some concerns about whether some vehicle sizes or shapes (such as the Sprinter van) would be suitable for testing with a JRS device.

- *Vehicle performance criteria and instrumentation*—There are no generally accepted criteria to evaluate vehicle performance in rollover crashes. We would need to investigate measurement devices for relevancy with the JRS.

- *Initial lateral acceleration*—The JRS does not take into account the initial lateral

acceleration in a real world rollover. This may have implications when testing with a dummy and potentially measuring performance related to some safety countermeasures (e.g., ejection containment side curtain bags and pretensioners). If a dummy's position in the test is not correlated to real-world rollovers, then the assessment of pretensioners and side window air bags in the JRS test is put into question.

Lack of Real-World Data To Feed Into the Test Parameters

- At this time, NHTSA has only limited event data recorder (EDR) data from rollover sensor-equipped vehicles. It is hoped that data from these vehicles can provide a better understanding of the range of initial roll rate and trip angles for real world rollover crashes. As voluntarily-installed EDRs continue to be installed in the fleet, the agency will gather an increasing amount of data on real world rollover crashes. Currently, the agency does not have enough of these data to evaluate how the JRS test might be optimized to real world rollover conditions.

- The ongoing implementation of ESC systems complicates the evaluation of real world rollover crashes. ESC systems are anticipated to be highly effective in reducing single vehicle rollover crashes. These crashes tend to have the highest number of quarter turns. The federally mandated implementation of ESC systems is expected to dramatically alter the distribution of rollover crash conditions.

- Assuming that real world representative test conditions could be established, NHTSA would still need to conduct a fleet study to examine the safety performance in a JRS test, evaluate how well the test results relate to real world safety performance, and determine whether or not there would be any appreciable safety improvement beyond existing FMVSSs.

Test Dummy Issues

- *Lack of test dummy and injury criteria*—At this time, no anthropomorphic test device (ATD) or crash test dummy, has been designed for use in rollover crash tests. Existing ATDs used in rollover crash tests, such as the Hybrid III dummy lack lateral kinematic behavior as well as lateral impact biofidelity. In addition, new injury criteria beyond those currently developed for frontal and side impacts would need to be developed for the types of loading conditions that result in head, neck, and face injuries associated with roof contact.

- *Repeatability of test dummy and initial restraint positioning*—Because the JRS is spinning prior to initiating the vehicle test, there are concerns about how to establish the initial belt position on the ATD in a manner that is consistent with real world conditions. The lateral acceleration prior to rollover initiation (as discussed previously) can cause a belted occupant to introduce slack in the belt. There is also the additional complication of the timing for firing the rollover curtains and/or pretensioners in the JRS pre-spin cycle.

There are also issues concerning the biomechanical basis for the CFIR

⁵⁰ Friedman D., Nash C.E., "Advanced Roof Design for Occupant Protection," 17th ESV Conference, Amsterdam, 2002

⁵¹ See Docket NHTSA 2008-0015: 2003 Subaru Forester, 2004 Subaru Forest, 2004 Volvo XC90, 2006 Chrysler 300, 2006 Hyundai Sonata.

recommended performance criteria. Specifically, we have concerns about CFIR recommended axial neck load criteria, and the surrogate (intrusion speed and amplitude), having potential to predict neck injury in the real world. We note that in response to CFIR's injury metrics, Nissan submitted an analysis conducted by David C. Viano, Ph.D. from ProBiomechanics evaluating their findings. Viano found no correlation between impact force and head impact velocity based upon the available cadaver data CFIR used in its analysis. We believe this is an important issue, and believe that lateral moments may be equally or more significant than axial force in predicting cervical spine injuries. Absent other information we believe further research would be needed as to whether the recommended neck axial loads and/or roof intrusion velocity are appropriate criteria.

As to the issue raised by Mr. Nash, the agency reviewed the Toyota NASS cases he provided, and the damage patterns to the roof were consistent with other cases the agency has analyzed. Neither the agency nor Mr. Nash identified a catastrophic collapse of the header. The integrity of the roof was maintained in all but one of the crash events cited. NHTSA also reviewed the JRS 2007 Toyota Camry tests and compared the results to the NASS data. The Camry was tested twice on the driver's side of the vehicle. When the driver's side was tested the first time, there was no appreciable damage to the header. The driver's side of the same vehicle was then tested again and showed some minor header damage. This test methodology is inconsistent with a real world rollover as the far side of the vehicle was not damaged in either JRS test and yet the driver's side was tested twice.

While we appreciate the information provided by the commenters, we do not believe that the information is sufficient for consideration of the JRS as a possible test device for a Federal motor vehicle safety standard at this time. The concept and the ability of the fixture to rotate a vehicle and contact the roadway have been demonstrated. However, as indicated above, there are numerous technical issues related to the test and potential parameters as well as a suitable ATD and associated injury criteria or other metric.

Controlled Rollover Impact System (CRIS)

In the NPRM, NHTSA stated its belief that the CRIS device is helpful in understanding occupant kinematics during rollover crashes. However, we also stated that we believe that the device does not provide the level of repeatability needed for a regulatory

requirement, because the CRIS test is repeatable only up to the initial contact with the ground. After initial roof impact, the CRIS test allows the vehicle to continue rolling, resulting in an unrepeatability test condition.

Two commenters provided support for the CRIS test procedure. The commenters were CFIR⁵² and Technical Services. CFIR provided summary information on the repeatability of the initial conditions, and certain occupant injury measures for the CRIS test procedure. Technical Services recommended that the CRIS test should be considered by the agency for dynamic roof crush testing.

Agency Response

The CRIS test procedure was developed to produce repeatable vehicle and occupant kinematics for the initial vehicle-to-ground contact. No data have been provided indicating that the procedure is repeatable after initial ground contact, and we would not expect it to be given that the CRIS test allows the vehicle to continue rolling. While it is notable that some of the injury criteria appear to be repeatable for the first ground contact, the relevance of the dummy measurements for rollover impacts has not been established. Evaluating performance criteria for the CRIS test would depend upon the development of an ATD with biofidelity in rollover crash tests. We believe a long-term research program would be necessary to develop performance measures, evaluate the repeatability, reproducibility, and any potential real world correlation of this test procedure.

Inverted Vehicle Drop Test

In the NPRM, the agency stated that its research found that the inverted drop test does not replicate real-world rollovers better than the current quasi-static test. We stated further that the inverted drop test does not produce results as repeatable as the quasi-static method.

The agency received three comments on the inverted vehicle drop test. Commenters included SAFE, Syson, and Technical Services. SAFE commented that the inverted drop test is superior to the quasi-static test because: (1) It is a dynamic evaluation; (2) it could evaluate multiple rollover safety systems; (3) it could incorporate restraint system effectiveness; and (4) it is a simple test procedure. Syson stated that the inverted vehicle drop test procedure provides more useful information about roof structure performance. Technical Services questioned the value of an inverted vehicle drop test less than 3 feet in height and the lack of lateral

loading, when compared to other dynamic dolly rollover tests.

Agency Response

We discussed issues related to the inverted drop test procedure at some length in the NPRM, including a discussion of agency research. NHTSA has previously conducted a test program to evaluate the relative merits of drop testing compared to the current quasi-static test procedure. The previous evaluation concluded that without a rollover ATD the roof drop test could not provide a complete safety performance test. If the test requirement is limited to measuring roof deformation as a surrogate for occupant injury potential, then the more controlled and repeatable quasi-static test procedure is preferable. The agency's research indicated that the static test can be related to the drop test with a moderate degree of accuracy. Because of an additional number of uncontrolled variables, such as consistent vehicle release, impact location and deformation measurements, drop test results can be expected to vary significantly, even for seemingly comparable test conditions.⁵³ Adding a lateral component to this test procedure to address concerns identified by Technical Services would add another level of complexity. The comments do not provide data or arguments to refute the positions taken by NHTSA in the NPRM.

Weight Drop Onto the Roof Test (WDORT)

In the NPRM, NHTSA did not discuss the weight drop onto the roof test (WDORT) since commenters on the prior roof crush resistance notice had not addressed this test. One commenter, Mr. Chu, recommended that NHTSA develop a dynamic WDORT and set the dynamic intrusion limit as a percentage of the headroom before impact. Chu stated the WDORT is not sensitive to a vehicle's CG like the inverted vehicle drop test and the test weight can be calibrated and guided within four rails during the drop. Mr. Chu did not provide a detailed test setup, procedure or test data to support his recommendation.

Agency Response

No details or test data were provided for the WDORT concept. Consequently, a considerable research effort would be required to evaluate the appropriateness and practicability of such an approach and whether it would provide any safety benefit beyond the quasi-static procedure.

Appendix B—Two-Sided Test Results

Vehicle	Peak SWR prior to 127 mm of platen travel or head contact (except as noted)		Peak force change (percent)
	1st Side	2nd Side	
2007 Toyota Tundra	3.3	2.2	-17.5
2008 Honda Accord**	3.5	4.0	n/a

⁵² Peltez submitted comments from the Center for Injury Research (CFIR) dated March 22, 2004. This

was originally submitted to Docket 1999-5572 (submission #12).

⁵³ Glen C. Rains and Mike Van Voorhis, "Quasi Static and Dynamic Roof Crush Testing," DOT HS 808-873, 1998.

Vehicle	Peak SWR prior to 127 mm of platen travel or head contact (except as noted)		Peak force change (percent)
	1st Side	2nd Side	
2007 Ford Edge	3.3	3.2	-3.6
2007 Chevrolet Colorado	2.2	1.7	-21.4
2007 Toyota Tacoma	3.3	3.7	12.4
2007 Chevrolet Express***	2.3	1.7	-27.3
2007 Jeep Grand Cherokee	2.2	1.6	-27.1
2007 Pontiac G6	2.3	1.7	-23.8
2005 Lincoln LS*	2.6	2.0	-21.3
2007 Saturn Outlook	2.7	2.2	-20.8
2003 Ford Crown Victoria*	2.0	1.7	-19.5
2007 Ford F-150	2.3	1.9	-19.0
2007 Chevrolet Tahoe	2.1	1.7	-16.4
2007 Toyota Yaris	4.0	3.4	-15.8
2005 Buick LaCrosse	2.6	2.2	-13.5
2007 Toyota Tacoma	4.4	3.9	-12.2
2007 Buick Lucerne	2.3	2.1	-10.8
2003 Chevrolet Impala*	2.9	2.5	-9.9
2004 Lincoln LS*	2.5	2.2	-8.7
2006 Subaru Tribeca	3.9	3.5	-8.3
2007 Scion tC	4.6	4.3	-6.7
2006 Chrysler Crossfire	2.9	2.7	-5.6
2007 Dodge Caravan	3.0	2.9	-5.3
2007 Honda CRV	2.6	2.5	-4.9
2005 Buick LaCrosse	2.4	2.3	-3.4
2004 Nissan Quest*	2.8	2.7	-3.0
2001 GMC Sierra*	1.9	1.9	-1.3
2007 Chrysler 300	2.5	2.5	1.6
2004 Chrysler Pacifica*	2.2	2.4	7.0
2007 Toyota Camry	4.3	4.7	9.0
2004 Land Rover Freelander*	1.7	2.0	19.2

* Crush of first side stopped at windshield cracking.

** First side test stopped at predetermined SWR.

*** Between the first and second side tests, the front door on the tested side was opened. Because of damage to the vehicle during the first side test, the door would not properly close. The door was clamped until the latch engaged, locking the door in place. This may have compromised the structural integrity of the roof and reduced the measured peak load on the second side.

Appendix C—Single-Sided Test Results

Vehicle	Unloaded vehicle weight (kg)	Peak strength within 127 mm of platen travel		Peak strength prior to head contact		Platen travel at head contact (mm)
		N	SWR	N	SWR	
2006 VW Jetta	1,443	72,613	5.1	72,613	5.1	158
2007 Scion tC	1,326	59,749	4.6	59,749	4.6	113
2006 Volvo XC90	2,020	90,188	4.6	N/A	N/A	N/A
2006 Honda Civic	1,251	55,207	4.5	55,207	4.5	177
2007 Toyota Tacoma	1,489	64,441	4.4	64,441	4.4	123
2006 Mazda 5	1,535	66,621	4.4	66,621	4.4	155
2007 Toyota Camry	1,468	62,097	4.3	62,097	4.3	N/A
2007 Toyota Yaris	1,038	41,073	4	41,073	4	115
2006 Ford 500	1,657	63,181	3.9	63,181	3.9	150
2007 Nissan Frontier	1,615	62,828	3.9	62,828	3.9	167
2006 Subaru Tribeca	1,907	72,306	3.9	72,306	3.9	112
2006 Mitsubishi Eclipse	1,485	51,711	3.6	51,711	3.6	127
2008 Honda Accord**	1,476	50,959	3.5	50,959	3.5	N/A
2006 Hummer H3	2,128	70,264	3.4	70,264	3.4	185
2007 Toyota Tacoma	1,752	56,555	3.3	56,555	3.3	N/A
2007 Toyota Tundra	2,345	76,216	3.3	76,216	3.3	N/A
2007 Ford Edge	1,919	61,910	3.3	61,910	3.3	N/A
2006 Hyundai Sonata	1,505	46,662	3.2	46,662	3.2	131
2007 Dodge Caravan	1,759	52,436	3	52,436	3	N/A
2006 Chrysler Crossfire	1,357	38,179	2.9	38,179	2.9	107
2004 Honda Accord	1,413	38,281	2.8	38,281	2.8	140
2007 Saturn Outlook*	2,133	57,222	2.7	57,222	2.7	N/A
2006 Ford Mustang	1,527	40,101	2.7	41,822	2.8	132
2005 Buick Lacrosse	1,590	40,345	2.6	40,345	2.6	126
2006 Sprinter Van*	1,946	49,073	2.6	N/A	N/A	N/A

Vehicle	Unloaded vehicle weight (kg)	Peak strength within 127 mm of platen travel		Peak strength prior to head contact		Platen travel at head contact (mm)
		N	SWR	N	SWR	
2004 Cadillac SRX	1,961	50,346	2.6	50,346	2.6	138
2007 Honda CRV	1,529	38,637	2.6	38,637	2.6	N/A
2007 Chrysler 300	1,684	41,257	2.5	41,257	2.5	N/A
2005 Buick Lacrosse	1,588	37,196	2.4	37,196	2.4	123
2006 Honda Ridgeline	2,036	47,334	2.4	47,334	2.4	172
2007 Ford F-150*	2,413	54,829	2.3	54,829	2.3	N/A
2007 Buick Lucerne	1,690	38,268	2.3	38,268	2.3	N/A
2004 Chevrolet 2500 HD*	2,450	55,934	2.3	56,294	2.3	171
2007 Pontiac G6	1,497	33,393	2.3	33,393	2.3	124
2007 Chevrolet Express*	2,471	55,038	2.3	55,038	2.3	N/A
2007 Jeep Grand Cherokee	1,941	41,582	2.2	41,582	2.2	117
2007 Chevrolet Colorado	1,560	33,299	2.2	33,299	2.2	N/A
2007 Chevrolet Tahoe*	2,462	49,878	2.1	49,878	2.1	N/A
2006 Dodge Ram*	2,287	37,596	1.7	42,578	1.9	158
2003 Ford F-250*	2,658	44,776	1.7	44,776	1.7	205

* GVWR greater than 6,000 pounds.

** Test stopped at 3.5 SWR.

[FR Doc. E9-10431 Filed 5-11-09; 8:45 am]

BILLING CODE C