

DEPARTMENT OF HOMELAND SECURITY

Coast Guard

33 CFR Parts 155 and 157

46 CFR Part 162

[Docket No. USCG–2004–18939]

RIN 1625-AA90

Pollution Prevention Equipment

AGENCY: Coast Guard, DHS.

ACTION: Interim rule; request for comments.

SUMMARY: The Coast Guard is amending its oil pollution prevention equipment regulations to make them consistent with new International Maritime Organization (IMO) guidelines and specifications issued under the International Convention for the Prevention of Pollution from Ships (MARPOL) Annex I. These revisions will implement MARPOL Annex I regulations and are intended to reduce the amount of oil discharged from vessels and eliminate the use of ozone-depleting solvents in equipment tests. This interim rule will require all vessels replacing or installing oil separators and bilge alarms to install equipment that meets revised standards and it will require newly constructed vessels carrying oil in bulk to install monitoring systems that meet the revised standards. We have delayed the implementation of three paragraphs involving vessels constructed and equipment installed on or after January 1, 2005. We seek comments on these three paragraphs and will consider those comments before issuing a final rule.

DATES: *Effective dates:* This interim rule is effective March 17, 2009, with the exception of paragraphs 33 CFR 155.350(a)(3), 155.360(a)(2), and 155.370(a)(4), which are effective October 13, 2009.

Comment date: Comments on paragraphs 33 CFR 155.350(a)(3), 155.360(a)(2), and 155.370(a)(4) must reach the Docket Management Facility on or before April 16, 2009.

Incorporation by reference: The incorporation by reference of certain publications listed in the regulations is approved by the Director of the Federal Register as of March 17, 2009.

ADDRESSES: You may submit comments identified by docket number USCG–2004–18939 using any one of the following methods:

- (1) *Federal eRulemaking Portal:*
<http://www.regulations.gov>.
- (2) *Fax:* 202–493–2251.

(3) *Mail:* Docket Management Facility (M–30), U.S. Department of Transportation, West Building Ground Floor, Room W12–140, 1200 New Jersey Avenue, SE., Washington, DC 20590–0001.

(4) *Hand delivery:* Same as mail address above, between 9 a.m. and 5 p.m., Monday through Friday, except Federal holidays. The telephone number is 202–366–9329.

To avoid duplication, please use only one of these methods. For instructions on submitting comments, see the “Public Participation and Request for Comments” portion of the **SUPPLEMENTARY INFORMATION** section below.

FOR FURTHER INFORMATION CONTACT: If you have questions on this interim rule, call Mr. Wayne Lundy, Systems Engineering Division (CG–5213), Office of Design and Engineering Standards, U.S. Coast Guard, telephone 202–372–1379. If you have questions on viewing or submitting material to the docket, call Renee V. Wright, Program Manager, Docket Operations, telephone 202–366–9826.

SUPPLEMENTARY INFORMATION:

Table of Contents

- I. Public Participation and Request for Comments
 - A. Submitting comments
 - B. Viewing comments and documents
 - C. Privacy Act
 - D. Public meeting
- II. Abbreviations
- III. Regulatory History
- IV. Background and Purpose
 - A. Types of Equipment
 - B. Authority
 - C. International Standards Being Implemented
- V. Discussion of Comments and Changes
 - A. Test and Performance
 - B. Measurement of Oil Content
 - C. Calibration
 - D. Training
 - E. Operating Requirements
 - F. Simulated Shipborne Environment
 - G. Operating Manual
 - H. Applicability
 - I. PPE Alternatives
 - J. Data Recording
 - K. Test Rig
 - L. Response Time
 - M. Test Fluid
 - N. Incorporating MEPC.107(49) by Reference
 - O. Test Report
 - P. Cleaning Detergent in Engine Room
 - Q. PPE Design
 - R. Oil Categories
 - S. Beyond the Scope of This Rulemaking
 - T. Changes from Proposed Rule
- VI. Incorporation by Reference
- VII. Regulatory Analyses
 - A. Regulatory Planning and Review
 - B. Small Entities
 - C. Assistance for Small Entities

- D. Collection of Information
- E. Federalism
- F. Unfunded Mandates Reform Act
- G. Taking of Private Property
- H. Civil Justice Reform
- I. Protection of Children
- J. Indian Tribal Governments
- K. Energy Effects
- L. Technical Standards
- M. Environment

I. Public Participation and Request for Comments

We encourage you to participate in this rulemaking by submitting comments and related materials. All comments received will be posted, without change, to <http://www.regulations.gov> and will include any personal information you have provided.

A. Submitting Comments

If you submit a comment, please include the docket number for this rulemaking (USCG–2004–18939), indicate the specific section of this document to which each comment applies, and provide a reason for each suggestion or recommendation. You may submit your comments and material online, or by fax, mail or hand delivery, but please use only one of these means. We recommend that you include your name and a mailing address, an e-mail address, or a phone number in the body of your document so that we can contact you if we have questions regarding your submission.

To submit your comment online, go to <http://www.regulations.gov>, select the Advanced Docket Search option on the right side of the screen, insert “USCG–2004–18939” in the Docket ID box, press Enter, and then click on the balloon shape in the Actions column. If you submit your comments by mail or hand delivery, submit them in an unbound format, no larger than 8½ by 11 inches, suitable for copying and electronic filing. If you submit them by mail and would like to know that they reached the Facility, please enclose a stamped, self-addressed postcard or envelope. We will consider all comments and material received during the comment period and may change this rule based on your comments.

B. Viewing Comments and Documents

To view comments, as well as documents mentioned in this preamble as being available in the docket, go to <http://www.regulations.gov>, select the Advanced Docket Search option on the right side of the screen, insert USCG–2004–18939 in the Docket ID box, press Enter, and then click on the item in the Docket ID column. If you do not have access to the internet, you may view the

docket online by visiting the Docket Management Facility in Room W12-140 on the ground floor of the Department of Transportation West Building, 1200 New Jersey Avenue, SE., Washington, DC 20590, between 9 a.m. and 5 p.m., Monday through Friday, except Federal holidays. We have an agreement with the Department of Transportation to use the Docket Management Facility.

C. Privacy Act

Anyone can search the electronic form of comments received into any of our dockets by the name of the individual submitting the comment (or signing the comment, if submitted on behalf of an association, business, labor union, etc.). You may review a Privacy Act notice regarding our public dockets in the January 17, 2008 issue of the **Federal Register** (73 FR 3316).

D. Public Meeting

We do not now plan to hold a public meeting. But you may submit a request for one to the Docket Management Facility at the address under **ADDRESSES** explaining why one would be beneficial. If we determine that one would aid this rulemaking, we will hold one at a time and place announced by a later notice in the **Federal Register**.

II. Abbreviations

API	American Petroleum Institute
CFC 113	Chlorofluorocarbon-113
CFR	Code of Federal Regulations
DHS	Department of Homeland Security
EPA	Environmental Protection Agency
FR	Federal Register
GC Method	Replacement hydrocarbon-gas chromatography method
GMT	Greenwich Mean Time
IMO	International Maritime Organization
IOPP	International Oil Pollution Prevention
IR method	Freon-infrared spectrophotometer method
ISO	International Organization for Standardization
MARPOL	International Convention for the Prevention of Pollution from Ships
MEPC	Marine Environment Protection Committee
NARA	National Archives and Records Administration
NEPA	National Environmental Policy Act
NPDES	National Pollution Discharge Elimination Standards
NPRM	Notice of Proposed Rulemaking
NTTAA	National Technology Transfer and Advancement Act
OCIMF	Oil Companies International Marine Forum
OMB	Office of Management and Budget
ORB	Oil Record Book
OWS	Oily-Water Separator
PPM	Parts Per Million
§	Section symbol
SRM	Standard Reference Material
UL	Underwriters Laboratories, Inc.
U.S.C	United States Code
USDA	United States Department of Agriculture

III. Regulatory History

On November 3, 2005, we published a notice of proposed rulemaking (NPRM) entitled “Pollution Prevention Equipment” in the **Federal Register** (70 FR 67066). We received 17 letters containing 80 comments on the proposed rule. No public meeting was requested and none was held.

On December 15, 2005, we published a correction notice in the **Federal Register** (70 FR 74259). The NPRM, as published, contained the phrase “must be limited” at two points, once in the preamble and once in the regulatory text. We deleted that phrase because it was inserted by error and could have confused readers.

IV. Background and Purpose

This interim rule will implement international standards for oil pollution prevention equipment designed for ships and oil tankers. These standards address the testing, certification, and approval for oil pollution prevention equipment, including discharge

monitors, which will help prevent oily discharges from a ship into the water.

A. Types of Equipment

There are two types of equipment involved in this rulemaking that deal with oil, water, and other substances that collect in the machinery space bilges of ships:

A *bilge separator* (also referred to as oily-water separator), is designed to produce an effluent from the bilge of ships with oil content of 15 parts per million (ppm) or less; and

A *bilge alarm* is designed to activate an automatic stopping device when the oil content concentration exceeds 15 ppm, and thus stop any discharge overboard of oily-mixtures with an oil content exceeding 15 ppm.

This rulemaking also involves equipment used on tankers to process oil-tanker ballast and tank-washing water. The *oil discharge monitoring and control system* (“*monitoring system*”) monitors the discharge into the sea of oily ballast or other oil-contaminated water from the cargo tank areas. This

monitoring system contains an *oil content meter* (hereinafter “*meter*”) that measures the oil content of the effluent in ppm.

B. Authority

The Coast Guard has authority to issue this regulation. Under the Act to Prevent Pollution from Ships, Public Law 96-478, sections 2 and 4, 94 Stat. 2297, 2298 (Oct. 21, 1980), 33 U.S.C. 1901 and 1903, the Secretary of the Department in which the Coast Guard is operating is authorized to prescribe any necessary or desired regulations to carry out the provisions of the Act and of Annex I (Regulations for the prevention of pollution by oil) of the International Convention for the Prevention of Pollution from Ships, 1973, as modified by the Protocol of 1978 relating to that Convention (MARPOL 73/78). Under the Act of August 26, 1983, Public Law 98-89, 97 Stat. 500, 504, 522, subtitle II of title 46 of the U.S. Code (46 U.S.C.), specifically 46 U.S.C. 3703, the Secretary in which the Coast Guard is operating is authorized to issue

equipment regulations, and related maintenance and training regulations for vessels carrying liquid bulk dangerous cargo, including oil. Authority under both of these acts has been delegated to the Coast Guard under Department of Homeland Security Delegation No. 0170.1(2)(77) and (92)(b).

C. International Standards Being Implemented

This rulemaking implements revisions to the international oil pollution prevention standards for ships in MARPOL Annex I, specifically regulations 14, 18, and 31. Under Article 38 of the Convention on the International Maritime Organization (IMO), the IMO Marine Environment Protection Committee (Committee) is designated to consider IMO matters involving the prevention and control of marine pollution from ships.

In 1992, during its 33rd session, the Committee adopted a resolution, MEPC.60(33), containing guidelines and specifications for pollution prevention equipment for machinery space bilges of ships. In 2003, recognizing the advancement of technology since 1992, the Committee adopted resolution MEPC.107(49), which contained new guidelines and specifications that superseded those adopted in 1992.

The MEPC.107(49) changed the fluids used to test pollution prevention equipment so they would more closely represent the bilge wastes encountered on vessels. Emulsified oil in water, surfactants (for example, detergents), and other contaminants are typically found in bilge water. Under MEPC.107(49), the bilge separator must be capable of separating the oil from the emulsion to produce an effluent with an oil content not exceeding 15 ppm.

The MEPC.107(49) also changed the method by which oil content is measured in effluent samples during the approval process. Past methods permitted the use of ozone-depleting solvents, specifically carbon tetrachloride and Freon 113 (CFC 113). Both an international treaty and United States laws call for phasing out the use of these solvents. See the Montreal Protocol on Substances that Deplete the Ozone Layer ("Montreal Protocol"), Sept. 16, 1987, 26 I.L.M. 1550, and Title VI of the Clean Air Act, 42 U.S.C. 7671–7671q. Accordingly, MEPC.107(49) specifies a different test method that does not use ozone-depleting solvents.

The MEPC.107(49) guidelines and specifications were incorporated into Annex I after the 2004 adoption of resolution MEPC.117(52), which led to the revision of MARPOL Annex I. On January 1, 2007, the revised Annex I

came into force. Resolution MEPC.107(49) is incorporated into Regulation 14 (Oil filtering equipment) of the revised Annex I.

Additionally, in 2003, the Committee also adopted resolution MEPC.108(49), which revised guidelines and specifications for oil discharge monitoring and control systems for oil tankers constructed after 2004. These new guidelines and specifications were incorporated into Regulations 18 (Segregated Ballast Tanks) and 31 (Oil discharge monitoring and control system) of the revised Annex I and apply to oil content meters as part of oil discharge monitoring and control systems installed on tankers constructed after 2004. Because of revisions to MARPOL Annex II, effective January 1, 2007, neither resolution MEPC.108(49) nor the resolution it is replacing, A.586(14), are referenced in Annex II.

The new MEPC.108(49) guidelines and specifications call for:

- Only one category of a monitoring system to apply to all tankers of 150 gross tonnage and above;
- The monitoring system to be able to record position (latitude and longitude) from a vessel-position indicating device, allowing more accurate input of speed parameters;
- Greater control of oil mixture discharges by tightening the accuracy requirements for both the oil content meter and the flowmeter; and
- A more objective specification for identifying crude oils: Simply by number and assigned characteristics and parameters—such as density, viscosity, and cloud point—rather than geographical denominations used in Resolution A.586(14).

See IMO Subcommittee on Ship Design and Equipment Report to the Maritime Safety Committee, DE 46/32 at 12 & 13 (April 4, 2003).

V. Discussion of Comments and Changes

In response to our NPRM, we received a total of 80 comments reflected in the 73 issues presented below.

A. Test and Performance

Commenters raised 18 issues regarding the testing and performance of PPE.

Issue 1: One commenter stated that the paragraph 1.2.15, Shutoff test in the Annex to MEPC.108(49) for the oil content meter ("meter"), should be renamed the "Dry Operation While Energized Test" and that to ensure that our regulation achieves its apparent purpose—allowing observation of the reaction of a non-lubricated meter, the

shutoff time should be increased to at least 24 hours.

Response: The Coast Guard disagrees. The duration of shutoff we specify in 46 CFR 162.050–27(k) matches MEPC.108(49): 8 hours. This simulates a short period of inactivity of the meter, and thus we believe the current title is accurate. Adding 1 to 2 days to this test is not necessary. Our shutdown and restart test in 46 CFR 162.050–27(n) maintains the existing 1-week shutdown requirement.

While we did not change the title of the Shutoff test, this and other comments demonstrated the need to better align our terms with MEPC.108(49) as well as our current pollution certificate requirements in 33 CFR part 151, subpart A. In aligning with MEPC.108(49), we have removed the term "cargo monitor" because it can be interpreted either as a oil content meter or oil discharge monitoring and control system ("monitoring system"). In 33 CFR part 157, we no longer use "cargo monitor" to identify the "monitoring system." Also, in 46 CFR part 162, we have replaced the term "cargo monitor" with the term "oil content meter." In defining "oil content meter", we used the same definition for "cargo monitor" in the proposed rule, except that we removed a reference to a recordkeeping function. To ensure uniformity in the CFR parts involved, we made nomenclature changes in some sections or paragraphs that were not included in the proposed rule: §§ 155.380(a) and (b), 157.03 "clean ballast" definition paragraph (2), 157.11(b)(2)(iii), 157.37(a)(6), (c) and (d), 157.43(a) and (b), 162.050–5(a)(8), 162.050–7(i), 162.050–11(a) and (b)(8), and 162.050–19(a) and (c).

Issue 2: After discussing the 8-hour shutoff test in paragraph 2.2.8 of the Annex to MEPC.107(49), which was reflected in § 162.050–35(e) of our proposed rule, one commenter said that the 46 CFR subpart 162.050 test protocol requiring bilge alarms to be shutoff for 7 days should be retained as the true "ShutOff" test.

Response: The current requirement in § 162.050–35(i), Test No. 7A, specifies that the bilge alarm be shutoff for 1 week and then tested. We have retained this useful 1-week shutoff test in § 162.050–35(i) of the interim rule and renamed it "Test No. 8A Shutdown and Restart Test." We have also retained the 8-hour shutoff test appearing in § 162.050–35(e), Test No. 4A Shutoff Test, of the proposed rule. We made no changes from the proposed rule based on this comment.

Issue 3: One commenter stated that the "Calibration and Zero Test",

paragraph 1.2.5 of the Annex to MEPC.108(49), uses “calibration” for what we would classify as “capability,” and that this test should be run as a comparative test with the influent and effluent sampled as the cargo monitor (monitoring system) output display is read and recorded. The commenter also stated the value of the influent and effluent should be within ± 10 parts per million (ppm) of the cargo monitor display at the time of sampling.

Response: The Coast Guard disagrees with the commenter. We believe that this test constructs a calibration curve up to the maximum capability of the equipment. The fact that this test also establishes the capability of the unit is secondary to its intended purpose. However, this comment has revealed that this testing requirement was insufficiently written in the NPRM as it did not specifically mention the creation of a calibration curve. The regulatory text in 46 CFR 162.050–27(b) and (c) has been revised to correct this omission.

Regarding the ± 10 ppm comment, this was addressed in proposed § 162.050–7(i)(2) (Approval procedures), which we did not change in the interim rule.

Issue 4: One commenter said that the “Oil Fouling and Calibration Shift Test”, paragraph 1.2.9 of the Annex to MEPC.108(49), should be a comparative test with the only other requirement being that the monitoring system be capable of being cleaned or self-cleaned from the influent. The commenter also noted that using the test stand’s current configuration may allow heavy oil to permeate the fittings on the test stand plumbing and cause fluctuations in the influent concentration.

Response: This comment made us realize that we should have included a sentence from MEPC.108(49) in our proposed rule. To correct this omission, we have redesignated § 162.050–27(e)(4) as (e)(5) and inserted a new paragraph (e)(4) that reads: “If it is necessary to clean the meter after each oil-fouling test for it to return to a zero reading, this fact and the time required to clean and recalibrate the meter must be noted and recorded in the test report.” Regarding the permeation of heavy oil in the test stand setup, we note this comment, but are adhering to MEPC.108(49) test stand specifications. Observations such as these should be included in the lab report.

Issue 5: One commenter suggested revising § 162.050–20(b)(2) to include a specific dilution ratio or stating that the amount of water added must be accounted for in the volume added under paragraph § 162.050–20(b)(3).

Response: The Coast Guard disagrees with this suggestion. We believe that the overall ratio for fluid C (for the testing of oily water separators and bilge alarms) is dictated by paragraph (a)(3) of § 162.050–20. In paragraph (b)(2), the proposed regulations call for the mixing of the surfactant with water in a “small container.” We believe that the amount of water needed to make the surfactant solution is insignificant compared to the amount of water required for paragraph (b)(3). We have amended the regulatory text, however, to clarify that the amount of water that may be used to comply with paragraph (b)(2) must be the minimum required for the creation of a complete surfactant solution.

Issue 6: One commenter stated that a new paragraph should be added near § 162.050–23(a) that bars changing filters, manually cleaning filters, or replacing consumable items during or between the tests.

Response: We agree with the concern expressed by the commenter, but note that the existing 46 CFR 162.050–23(a)(11) prohibits maintenance of the separator during or between the tests. In the interim rule, this paragraph has been redesignated as (a)(10). We made no changes from the proposed rule based on this comment.

Issue 7: One commenter said that the Coast Guard should consider influent concentrations tests of 200 ppm and 1,000 ppm because common separator technologies, such as gravity coalescence, generally have an easier time separating higher concentrations of oil in water.

Response: The Coast Guard disagrees. While gravity coalescence may demonstrate better performance at the stated concentrations, it would be difficult to stipulate optimum concentrations for each method without making the test regime overly prescriptive. Therefore, we made no changes from the proposed rule based on this comment.

Issue 8: One commenter asked if the concentration stated in § 162.050–23(b)(1) should be constant throughout Test 1A or vary between 5,000 and 10,000 ppm. If the concentration should be constant, the commenter recommended setting a specific concentration. If not, then require that the same user-selected concentration also be used in Test 1B.

Response: The recognized lab must select a concentration within a range of 5,000 to 10,000 ppm. The selected concentration must remain consistent throughout the test. We have made a slight revision in the text of § 162.050–23(b)(1) to make this point clearer. The same test run for test fluid B could be

at a different concentration within the same range, but again we have decided to leave this selection to the discretion of the test lab.

Issue 9: One commenter stated that calibration and zeroing should be allowed only at the onset of the bilge alarm tests if the manufacturer recommends it.

Response: The Coast Guard agrees. We revised § 162.050–35(b)(3) to remove the calibration and re-zeroing requirement between tests. This requirement should not have been included in the proposed rule.

Issue 10: One commenter said that a new paragraph (a)(4) should be added to § 162.050–35 and read as follows: “No maintenance, including replacement of parts, may be performed on a bilge alarm during or between the tests described in this section.” The commenter also added that because this applies to separator approval tests, it should apply to bilge alarms too.

Response: The Coast Guard agrees with the need for a revision, but we have revised a different paragraph. We added a sentence—“No maintenance, including replacement of parts, may be performed on a meter during or between the tests described in this section.”—to § 162.050–27(a)(1). These requirements must be complied with for bilge alarm approval tests under a new § 162.050–35(a)(1).

Issue 11: One commenter suggested adding new steps in the calibration and zero test between paragraphs (b)(2) and (b)(3) in § 162.050–35 to ensure the bilge alarm makes the correct decision of allowing or disallowing overboard discharge. Another commenter recommended adding new steps in the calibration and zero drift test between paragraphs (g)(2) and (g)(3) in § 162.050–35 to ensure the bilge alarm makes the correct decision of allowing or disallowing overboard discharge.

Response: In both cases, the Coast Guard disagrees. Tests for the concentration that triggers the alarm and how long the alarm takes to be triggered are already contained in § 162.050–35(d) (ppm level sample pressure or flow test) and (h) (response time test). The results of these two tests will indicate whether the bilge alarm activates an automatic stopping device when it should and thus stop the discharge overboard of oily mixtures with an oil content exceeding 15 ppm. Therefore, we did not make the requested changes.

Issue 12: One commenter stated that the pass/fail criteria for the test in § 162.050–35(c) is unclear.

Response: The criteria for approval of a bilge alarm for certification are contained in 46 CFR 162.050–7(j) and

include an accuracy standard of 15 ppm \pm 5 ppm. We made no changes based on this comment.

Issue 13: One commenter recommended testing the bilge alarm at the minimum and maximum design pressure or flow rate instead of one half and at twice the maximum design pressure or flow rate. They stated testing the bilge alarm at twice the maximum design pressure does not provide useful information and may damage the unit.

Response: While the recommendation appears to provide a sound alternative, we have maintained the current language of § 162.050–35(d) because it is consistent with paragraph 2.2.7 of the Annex for MEPC.107(49). Further, this test has been used internationally for several years, and we are not aware of any bilge alarms damaged by this test. We made no changes from the proposed rule based on this comment.

Issue 14: One commenter asked if the purpose of the last phase of Test No. 6A in proposed § 162.050–35(g)(3) was to collect samples of clean water. If not, then the procedure requires clarification.

Response: The purpose of this last phase is not to collect samples of clean water. To provide clarification, we have revised paragraph (g)(3) to better align it with paragraph 2.2.10 of the Annex to MEPC.107(49).

Issue 15: One commenter recommended adding language to start Test No. 7A in § 162.050–35(h) with a 0 ppm injection until the bilge alarm stabilizes and diverts flow “overboard,” followed by the 40 ppm injection. Furthermore, the commenter stated if you start at 40 ppm, the actuation point for the alarm may not be observed.

Response: The Coast Guard disagrees. We believe that the requirement in the preceding test in § 162.050–35(g)(3) accomplishes the initial conditions the commenter seeks by adding a 0 ppm injection in § 162.050–35(h) for Test No. 7A and, as specified in § 162.050–35(a), these tests must be performed in sequence. We made no changes from the proposed rule based on this comment.

Issue 16: One commenter said that Test No. 6A in § 162.050–35(g) should be titled “Calibration and Zero Drift Test” to distinguish it from Test No. 1A in the same section.

Response: The Coast Guard agrees. We have revised the test name to “Test No. 6A Calibration and Zero Drift Test.”

Issue 17: One commenter stated that the lab representative conducting the test should verify and state on the test report all parameters of the testing, including the test’s start and end time. The report should include verification and documentation that all test fluids

were in conformity with those specified and that test fluid C was a “stable” emulsion. This should apply to the tests for both the monitoring system and the separator. Any unit submitted without testing all three fluids concurrently should be rejected.

Response: The Coast Guard believes that the information currently required in test reports by 46 CFR 162.050–9 is sufficient for a determination of whether MEPC PPE standards have been met. We also believe that the regulations, as proposed and adopted in this interim rule, are clear that the three test fluids should be tested for both the separator and bilge alarm, in order, and as one continual series of tests, without pause, as far as practicable. We made no changes based on this comment.

Issue 18: One commenter said that the 15 ppm bilge alarm device functions as a key component in the overall performance of the separating equipment. Therefore, these 15 ppm bilge alarm devices should also be included in the separator testing procedure so the accuracy can be measured against the chemical analysis of the clean water discharge.

Response: The Coast Guard disagrees that all bilge alarms should always be tested with separators, however, separators with integral bilge alarms should be tested as one unit. Therefore, we have added new paragraph § 162.050–23(a)(13) stating: “If a separator has an integral bilge alarm, the separator must be tested with the bilge alarm installed.”

B. Measurement of Oil Content

Commenters raised eight issues regarding the measurement of oil content.

Issue 19: One commenter suggested eliminating § 162.050–39(b) to better conform with IMO resolutions MEPC.107(49) and MEPC.108(49) because the infrared spectrophotometer assay mentioned in that paragraph is not permitted in the current IMO regulations. The commenter also believes the reagent used in the infrared spectrophotometer assay is no longer available in its pure, unused form.

Response: The Coast Guard agrees. We do not believe that any laboratories would benefit from a phasing-out of the test permitted under § 162.050–39(b). Therefore, this paragraph has been removed consistent with our stated goal of eliminating the use of ozone-depleting reagents required by the test in § 162.050–39(b).

Issue 20: One commenter asked if the Coast Guard knows the “error bar” for the International Organization for Standardization (ISO) method given the

different ways it may be performed. The commenter suggested adding the error bar to the 15 ppm value so as not to preclude a separator whose “real” performance is 15 ppm or less. Another commenter stated the Coast Guard should ensure that the replacement hydrocarbon-gas chromatography (GC) method provides results comparable to the freon-infrared spectrophotometer (IR) method, and apply an adjustment factor to the ISO results if warranted.

One commenter said that the MEPC requires the use of ISO 9377–2 to determine oil content of separator and bilge alarm samples. The commenter recommended that the Coast Guard use EPA’s Method 1664A as the method of verification. If the ISO method is still the chosen method, the commenter recommended that § 162.050–39 reference the petroleum hydrocarbon extraction method used in 40 CFR part 136 to maintain consistent results.

Response: The Coast Guard does not have an “error bar” for the ISO 9377–2 method. We believe that conducting a comparison test of the GC method with the IR method is beyond the scope of this rulemaking. However, we welcome the results of any such comparison. Should verifiable results show an adjustment factor is needed, the Coast Guard would request that the United States bring this to the attention of the IMO for consideration of amendments to MEPC.107(49). We made no changes in response to this comment.

Issue 21: One commenter said the Environmental Protection Agency’s (EPA) Method 8015M should be used instead of the ISO 9377–2 method. The commenter stated the EPA method more closely represents the method that should be used, but understands ISO 9377–2 is an international standard and that the use of one nation’s method might not be as universally accepted.

Response: At this point, the Coast Guard does not have enough data to ensure the EPA method is equivalent. It is our desire to remain consistent with the IMO resolution. However, if a designated lab or manufacturer desires to use the EPA method in lieu of ISO 9377–2, they must show that it delivers equivalent results. Under 46 CFR 159.001–7, if an alternative method produces equivalent or better performance, we may accept oil-in-water analysis results based on that method. We made no changes from the proposed rule based on this comment.

Issue 22: One commenter recommended that the Coast Guard have discussions with the EPA regarding changes to ISO 9377–2 because 40 CFR part 136 calls for the use of Method 1664A to report oil, grease, and

petroleum hydrocarbons under National Pollution Discharge Elimination Standards (NPDES) permits.

Response: The United States has a responsibility to implement MARPOL Annex I as revised. This includes issuing regulations for approving oil pollution prevention equipment for vessels covered by MARPOL Annex I. In fulfilling this responsibility, the Coast Guard believes maintaining consistency with the IMO resolution is the best approach. Therefore, we made no changes in response to this comment.

Issue 23: One commenter recommended that the Coast Guard use EPA Method 1664 for hardware approval until the implications of using different measurement techniques for hardware approval and enforcement are resolved.

Response: As a Party to MARPOL Annex I, we have an obligation to implement the revised Annex. The Coast Guard believes that maintaining consistency with the IMO resolution is the best way to meet that obligation. We made no changes in response to this comment.

Issue 24: One commenter stated that the NPRM language should facilitate inclusion of alternate methods in the future. The commenter offered to work with the Coast Guard in defining a method that falls within the guidelines of ISO 9377-2, but is more specific.

Response: The Coast Guard currently has the regulatory authority to allow the use of alternative methods that demonstrate equivalent performance characteristics, under 46 CFR 159.007-1 and 159.005-7. Therefore, if a designated lab or manufacturer demonstrates an alternative method with equal or better oil-in-water analysis, then that analysis may be proposed in the lab's application to the Coast Guard for further consideration. We made no changes from the proposed rule in response to this comment.

Issue 25: One commenter asked if § 162.050-7(h)(2) means a 15 ppm separator will fail to receive Coast Guard approval if one or more samples are greater than 15 ppm as measured by ISO 9377-2. The commenter believes that an approved separator should pass the 15 ppm limit test for all conditions including emulsions since an emulsion is a key aspect of the MEPC.107(49) test.

Response: The commenter's interpretation is correct. The only difference from the existing text is that we have eliminated the words "In the case of a 15 ppm separator" because this distinction is no longer necessary. We made no changes in response to this comment.

Issue 26: The EPA suggested that we establish a reasonable, but specific date for discontinuation of the IR assay.

Response: As noted above, the Coast Guard removed § 162.050-39(b) from the rule. That paragraph would have permitted the continued use of IR assays, in place of the ISO 9377-2 GC method, so long as reagents for the IR assay remained available. By removing paragraph (b), we eliminated an inconsistency between our proposed rule and the revised MARPOL Annex I.

C. Calibration

Commenters raised 10 issues regarding calibration.

Issue 27: One commenter stated that the NPRM does not include procedures for sealing, breaking, and re-sealing oil content meter seals and recommended identifying procedures and personnel authorized to perform such tasks.

Response: As indicated in proposed 33 CFR 157.12c, a manufacturer's representative should conduct the breaking of meter seals during calibration and repair work. The procedures for routine maintenance and troubleshooting must be clearly defined in the Operating and Maintenance Manual and such work must be recorded. We made no changes in response to this comment.

Issue 28: One commenter stated that there are no valid reasons to restrict access to all basic meter check-and-test features. The commenter said that imposing these limitations would most likely lead to an unacceptable level of equipment operational disruptions in cases where simple testing/adjusting (re-zeroing) would rectify minor problems. The commenter recommended aligning with MEPC.107(49) on this issue.

Response: On December 15, 2005, we corrected the language in proposed 33 CFR 157.12c(e) (see 70 FR 74259), and we have since revised the language in 46 CFR 162.050-33(f) so both better align with the MEPC resolutions. Access for re-zeroing the instrument, checking for instrument drift, and checking the repeatability of the instrument reading will not be limited or require the breaking of a seal. But also consistent with the MEPC resolutions, 33 CFR 157.12c(a) and 46 CFR 162.050-33(f) specify that access beyond these controls would require the breaking of a seal of activation of another device which indicates an entry to the equipment.

Issue 29: A commenter found the requirement in paragraph 4.2.5 of MEPC.107(49) that "[i]t should not be necessary to calibrate the 15 ppm Bilge Alarm on board ship" confusing and challenging because the calibration

requires traceability, recordkeeping, expiration dates, due dates, and the use of calibration standards that effectively demonstrate traceability.

Response: The Coast Guard believes that paragraph 4.2.5 ensures that the reliability of the bilge alarm is tested and requires that the bilge alarm should be installed on the vessel in a calibrated condition. This paragraph also allows for onboard checking of the calibration per the manufacturer's instructions which, in 46 CFR 162.050-5(a)(6), we require to be submitted as part of the manufacturer's application for approval of a bilge alarm. In 46 CFR 162.050-35(b), we specify that the bilge alarm must be calibrated and zeroed using the manufacturer's instructions.

While we have made no changes based on this comment, as noted in our response below to Issue 36, we have added paragraph (d) to 33 CFR 155.380. That paragraph requires a check of the equipment during the International Oil Pollution Prevention (IOPP) certificate surveys. This calibration certificate must be retained onboard. We made no changes based on this comment.

Issue 30: One commenter stated that the Coast Guard should require action if a bilge alarm fails an onboard calibration test.

Response: This rulemaking incorporates the MEPC.107(49) changes relating to equipment design and testing. We feel that changing the current regulation to address equipment performance after installation is outside the scope of this rulemaking. However, we believe that the current IOPP survey regime assures the proper operation of the equipment prior to issuance/endorsement of the certificate. Basically, if an installed bilge alarm fails to calibrate, then the vessel would no longer be in compliance with MARPOL IOPP requirements. We made no changes in response to this comment.

Issue 31: One commenter stated that the regulation should address how drift repeatability and re-zeroing affect calibration.

Response: We believe that the full suite of tests, as prescribed, will give a good indication of the equipment's ability to maintain accuracy. In addition to the readings from the instrument, samples are taken and analyzed. Any variance between the reading and the sample concentration would be noted in the report. We made no changes in response to this comment.

Issue 32: Citing industry norms that calibration intervals never extend beyond 2 years, one commenter said that calibration intervals for bilge alarms should be no more than 2 years.

Response: Currently, under 33 CFR 151.17, the Coast Guard requires that PPE remains in satisfactory condition for the service intended and is checked during the annual IOPP surveys. We made no changes in response to this comment.

Issue 33: One commenter stated that the calibration test for bilge alarms in paragraph 2.2.5 of the Annex to MEPC.107(49), implemented through 46 CFR 162.050–35, should be adjusted so that a highly accurate and traceable input is used or renamed for what it is really doing—determining the stability of the meter and its sensors against varying oil types.

Response: The Coast Guard does not believe that a change is necessary. This test ensures the proper calibration of the bilge alarm using all three test fluids. We do not see a need to alter the name of the test.

Issue 34: One commenter stated that the proposed rule seems to shift the burden of calibration from shipboard operations to the manufacturer. Furthermore, the commenter stated that there should be a recognized standard for calibration because there must be a calibration process used by mariners operating meters and separators.

Response: Resolution MEPC.107(49) does not dictate a specific calibration standard. Furthermore, the Coast Guard believes that the calibration is for the meter only and not the main body of electronics to interpret the signal from the meter. The standard of calibration of the instrument (not the sensor) will be at the discretion of the third party the ship owner uses. We made no changes in response to this comment.

Issue 35: One commenter believes that the following wording in proposed 46 CFR 162.050–33 is unclear and somewhat contradictory to MEPC.107(49): “calibrating the bilge alarm must not be necessary once installed on board the vessel, however, on board testing in accordance with manufacturer’s instruction is permitted.”

Response: The Coast Guard agrees. We have revised this portion of § 162.050–33(d) to read: “calibrating the bilge alarm must not be necessary once installed onboard the vessel; however, onboard testing in accordance with the manufacturer’s operating instructions is permitted for the purposes of checking instrument drift and repeatability of the instrument reading, as well as the ability to re-zero the instrument.”

Issue 36: One commenter said that the same statement, “calibrating the bilge alarm must not be necessary once installed on board the vessel,” must be clarified to reflect that calibration may

be performed by the manufacturer or qualified personnel at an onshore facility.

Response: The Coast Guard agrees. We have added paragraph (d) to 33 CFR 155.380 to implement the requirements of MEPC.107(49) paragraph 4.2.11. This change will restrict calibration checks to the manufacturer or persons authorized by the manufacturer. It would be up to the manufacturer to prescribe where the calibration check may be conducted.

D. Training

Commenters raised one issue regarding training.

Issue 37: One commenter stated that the Coast Guard (and IMO) must ensure that new separating equipment is thoroughly field tested, standardized, and properly supported by mandatory “factory” training for any person expected to use it. Another commenter requested amending the final rule to mandate formal safety and vocational training in equipment operation and maintenance.

Response: The purpose and scope of this rulemaking is to issue PPE design, installation, and testing regulations that implement the revised MARPOL Annex I. The Coast Guard believes this interim rule achieves that goal. For clarification, however, we are adding paragraphs (e) and (f) to 33 CFR 155.380 regarding training and maintenance, respectively.

E. Operating Requirements

Commenters raised seven issues regarding operating requirements.

Issue 38: Regarding proposed 46 CFR 162.050–23(d), one commenter stated that the clean effluent line of the separator should be at least 90 percent of the influent flow rate for purposes of emulsion breaking.

Response: We disagree. This recommendation would require our regulations to be more prescriptive than our performance-based standard from paragraph 1.2.11.1 of the Annex to MEPC.107(49) of feeding a mixture to the separator composed of 6 percent Test Fluid C and 94 percent water by volume such that the emulsified Test Fluid C content is approximately 3,000 ppm in the test water until a steady flow rate occurs. We made no changes based on this comment.

Issue 39: Two commenters suggested adding a new paragraph to address the minimum service life for which bilge alarms should be designed. These commenters also raised material compatibility issues. They stated that the equipment should be suitable for seawater service, and compatible with oil, fuel, and bilge contaminants such as surfactants and particulates.

Response: We do not believe that it is within the scope of this rulemaking to require manufacturers to state the minimum service life of their product. Furthermore, the IMO resolutions do not address service life. As for the material compatibility issues, we believe that these are addressed in the plan review process specified in existing 46 CFR 162.050–5(a)(4), which requires the submittal of arrangement plans and piping diagrams in accordance with the requirements of 46 CFR 56.01–10(d). We made no changes based on these comments.

Issue 40: Responding to proposed 46 CFR 162.050–33, one commenter suggested adding a new paragraph to incorporate fail-safe design requirements for bilge-alarm systems. Specifically, they would require: (1) The bilge alarm to provide a control signal for the “overboard discharge control device”; (2) at least four consecutive bilge-alarm measurements must be below the alarm set-point before sending the control signal to allow overboard discharge; and (3) when the bilge alarm cannot obtain a reading due to interference or other causes, this must be considered a reading above the alarm set-point as it relates to No. (2).

Response: The Coast Guard disagrees as this suggested change is not in line with the requirements of MEPC.107(49) which are sufficiently designed to stop the discharge overboard of oily-mixtures with an oil content exceeding 15 ppm. We made no changes in response to this comment.

Issue 41: One commenter recommended adding a new paragraph (c)(3) in § 162.050–33 to describe a specific condition that would require the bilge alarm to produce a warning signal and a signal to actuate stop valves when “the concentration of interferences in the sample (e.g., emulsions, solids, color, air, bulk oil, etc.) may affect the bilge-alarm measurements.” Additionally, the commenter stated that interferences in the sample may cause erroneous bilge alarm measurements, thus resulting in an inadvertent overboard discharge of oily waste.

Response: While we agree with the commenter’s intent, we feel that this situation has been covered by § 162.050–33(c), which calls for stop valves to be activated when the oil content of the mixture measured exceeds 15 ppm or the bilge alarm malfunctions, breaks down, or otherwise fails to operate properly. Further, the proposed and adopted testing scheme includes tests for emulsions and solids. We made no changes in response to this comment.

Issue 42: Regarding 46 CFR 162.050–33(h), one commenter requested a definition of “operating status.” Additionally, the commenter wondered if “operating status” includes recording if the separator is on/off or in manual/automatic mode. Finally, the commenter also asked about the recording of separator valve positions and alarm conditions.

Response: Resolution MEPC.107(49) does not define operating status, however, a separator would likely have few operating conditions. These would include “manual” or “automatic” modes, “off,” and a cleaning or water-only flush cycle.

The bilge alarm must record when an alarm occurred, i.e., the “alarm condition,” with the date and time. While the resolution does not state that the ppm at the time the alarm occurred must be recorded, anything over 15 ppm should be prevented from going overboard. Neither the IMO resolutions nor Coast Guard regulations address the recording of valve positions; however, the option may be provided by manufacturers. We made no changes in response to this comment.

Issue 43: One commenter stated that there should be specifications mandating that the separators operate “essentially” unattended even in manned engine rooms.

Response: We agree with the commenter’s suggestion and have amended 46 CFR 162.050–21(e) to align with MEPC.107(49) by removing reference to “unattended machinery space.”

Issue 44: One commenter stated that separators should be required to start in the recirculation mode before entering a filtering phase.

Response: We believe that this change is too divergent from MEPC.107(49). Operationally, we believe that it is the function of the bilge alarm to cause the recirculation of the separator effluent. We do not believe that an additional recirculation stage is necessary. We made no changes in response to this comment.

F. Simulated Shipborne Environment

Commenters raised four issues regarding the simulated shipborne environment.

Issue 45: One commenter asked why the Coast Guard’s vibration test specification, which appears in § 162.050–37, is not fully aligned with the IMO specification. The commenter stated that the second 2-hour period of endurance is unlikely to show much more than the first period. The commenter also believed maintaining a different standard than the IMO

standard will cause continued confusion among manufacturers.

Response: We agree. We revised paragraphs (b) and (c) of 46 CFR 162.050–37 to align them with identical vibration tests in paragraph 3.2.2.1 of the Annex for MEPC.107(49) and paragraph 2.2.1.1 of the Annex for MEPC.108(49).

Issue 46: We received two comments stating that the proposed standards do not require that a separator be capable of operating while a vessel is underway and subject to vessel pitching, rolling, and vertical and horizontal “G” forces.

Response: The equipment is subjected to environmental testing designed to simulate the shipboard environment. Based on the proven abilities of the current approved separators to operate in a dynamic marine environment, we do not propose to require dynamic motion testing while operating the separators for the purposes of certification. We made no changes in response to this comment.

Issue 47: One commenter recommended that we conduct incline experiments for all three test fluids.

Response: The Coast Guard disagrees. We believe that the intent of the environmental testing portions of the IMO resolutions ensures the electrical and electronic sections of the equipment are capable of operating under the test conditions. Therefore, requiring this test to be conducted with all three fluids is excessive and not in line with the intent of the requirements. We made no changes based on this comment.

Issue 48: One commenter said that the Coast Guard should provide a list of fluids to conduct exposure tests.

Response: We disagree. Paragraph (d) of 46 CFR 162.050–21 requires compliance with 46 CFR chapter I, subchapter F—Marine Engineering, as applicable. Also the material specifications of the separator will be considered during plan review. We made no changes in response to this comment.

G. Operating Manual

Commenters raised two issues regarding the operating manual.

Issue 49: One commenter stated that the separator instruction booklet should be carefully written in easily-understood English.

Response: We agree. We have added an express requirement in § 162.050–5(a)(6) that the manual must be easily understood. We also adopted the naming convention of MEPC.107(49) and identified the manual as the “operating and maintenance manual.”

Issue 50: One commenter stated that the operations manual should provide

guidance on failure-logging of separators and guidance on obtaining system improvements.

Response: We disagree. We believe that our revision of requirements for manuals in § 162.050–5(a)(6) is consistent with MEPC.107(49). We made no changes in response to this comment.

H. Applicability

Commenters raised two issues regarding applicability.

Issue 51: One commenter stated that the proposed regulation’s applicability should be clearly addressed. Another commenter asked if the current bilge separators approved under MEPC.107(49) will remain “approved” after the new rule is adopted. And if that is the case, will there be different categories of approval (e.g., MEPC.107(49), MEPC.60(33), 46 CFR subpart 162.050). Another commenter asked if we intended for the rule changes to take effect upon acceptance of the rule or at a later date.

Response: Most sections of this interim rule will become effective March 17, 2009. The revised MARPOL Annex I became effective internationally January 1, 2007. Paragraph 1.3.1 of resolution MEPC.107(49), which was incorporated into the revised MARPOL Annex I Regulation 14, makes the resolution applicable to ships built on or after January 1, 2005, and to ships that install new PPE on or after January 1, 2005. This aspect of the revised Annex I was not reflected in our proposed rule. To implement these incorporated requirements, we have added three paragraphs—33 CFR 155.350(a)(3), 155.360(a)(2), and 155.370(a)(4)—to the interim rule requiring vessels built on or after January 1, 2005, and vessels that install new PPE on or after January 1, 2005, to meet the new PPE requirements. We are delaying the effective date of those paragraphs, so that we may seek your comments on them before making them effective. Based on your comments, we may revise these paragraphs before making them effective in a final rule.

Since publishing a notice of policy in December 2003 acknowledging the new MARPOL guidelines (68 FR 75603, December 31, 2003), we have approved some systems from PPE manufacturers who, in anticipation of the new MARPOL guidelines, sought Coast Guard approval under testing standards other than those in the current 46 CFR subpart 162.050. As the 2003 notice stated, the Coast Guard may, in its discretion, determine whether alternative standards ensured equivalent performance characteristics.

Systems approved under MEPC.60(33) that were installed before January 1, 2005, on vessels built before January 1, 2005, and are still in good working order will not be affected by this rule. Systems approved before the effective date of this rule using resolution MEPC.107(49) guidelines will remain approved. For any systems approved to a standard other than MEPC.107(49) after January 1, 2005, but before March 17, 2009, the approval will expire March 17, 2009.

Issue 52: One commenter stated that, if adopted, the new rules would apply to U.S.-flag ships only and recommended developing a requirement for identification of equipment built, tested, and certified for U.S.-flag vessels or alternatively adopt IMO standards in its entirety.

Response: We disagree. Current regulations in 33 CFR 155.380 stipulate compliance with 46 CFR 162.050 requirements for all U.S.-flag inspected vessels. Uninspected U.S.-flag vessels and foreign-flag vessels may either comply with 46 CFR 162.050 or MARPOL Annex I. (See discussion of § 155.380(b) in the *Changes from Proposed Rule* section below.) The identification of equipment built, tested, and certified for U.S.-flag vessels, is currently required by 46 CFR 162.050–11, Marking. We have not changed these current requirements.

I. PPE Alternatives

Commenters raised one issue regarding PPE alternatives.

Issue 53: One commenter requested that the Coast Guard consider properly designed and engineered holding tanks as a regulatory alternative to installing separator equipment that is unreliable and difficult to maintain on small vessels manned by lower-level mariners.

Response: This rulemaking implements PPE design and performance guidelines and standards in MEPC.107(49) and MEPC.108(49), and does not change which vessels must have PPE. Subpart B of 33 CFR part 155 and Regulation 16 of MARPOL Annex I dictate that ships of 400 gross tons or more must be fitted with PPE.

Our regulations require holding tanks on oceangoing ships over 400 gross tons in certain situations (see 33 CFR 155.360(b) and (c), and 33 CFR 155.370(b) and (c)), in addition to requiring the installation of approved PPE. We made no changes from the proposed rule based on this comment.

J. Data Recording

Commenters raised three issues regarding data recording.

Issue 54: One commenter asked if a vessel's speed and position-data requirement include the bilge alarm as well as the oil-discharge monitoring system.

Response: Neither the MEPC resolutions nor our proposed rules contain a requirement for bilge alarms to record the vessel speed and position. We made no changes in response to this comment.

Issue 55: One commenter stated that the proposed rule does not prevent overriding data inputs for failed equipment.

Response: This rule may only discourage, not prevent, overriding data inputs. However, those who tamper with the system will leave evidence in the form of broken seals on the bilge alarm. We made no changes based on this comment.

Issue 56: One commenter stated that a recording interval for bilge alarms is not specified in § 162.050–33(h). The commenter also wanted to know if our intent for bilge-alarm recording intervals is the same as in § 157.12d(h)(3) for oil content meters.

Response: Where the meter has a stated 10-minute interval, there is no required interval for the bilge alarm to print, display, or save a particular piece of information. The bilge alarm is merely required to save alarm events and operational status with a date and time stamp. The recorded information aids regulatory agencies in correlating separator-related entries in the oil record book. We made no changes from the proposed rule in response to this comment.

K. Test Rig

Commenters raised four issues regarding test rigs.

Issue 57: One commenter stated that the 30° chisel-edged chamfer in figure 162.050–17(d), Sample Point, should be around the outside perimeter instead of the inside perimeter of the sampler inlet to minimize disturbance of the sampling flow and to be consistent with MEPC.107(49).

Response: We agree and have corrected the chamfer illustrated in Figure 162.050–17(d).

Issue 58: One commenter recommended requiring the use of a syringe pump with a screw-type driver in place of the buret for oil injection at low concentrations to avoid pulsations of oil injections.

Response: The Coast Guard disagrees. Our figure at 46 CFR 162.050–19 and MEPC.107(49) figure 5 stipulate “burets and metering pumps for injecting known oil ppm's and high oil transients,” and thus provide discretion

to the testing lab to deliver the oil in the manner of its choosing. During the review of a facility's application under 46 CFR 162.050–15, we examine information on the facility's test rigs. Any deviation from the required test rigs must be noted in this information. We have no evidence of buret injections creating pulsations of oil injections at low concentrations. We made no changes in response to this comment.

Issue 59: One commenter recommended including the use of an inline disperser as an alternative to the high-shear pump to vary the oil droplets size distribution.

Response: The designated testing lab may propose alternative testing methods to the Marine Safety Center before beginning the tests. If agreed upon, any deviation from the required test rig must be noted in the test report or application. We made no changes from the proposed rule based on this comment.

Issue 60: One commenter suggested including the specifications of the tank used for Test Fluid C per Figure 3 and notes 1 through 3 of paragraph 1.2.4 of Part I of the Annex to MEPC.107(49) as it would ensure consistent mixing of Test Fluid C by different test facilities.

Response: The Coast Guard agrees. Our proposed paragraph (b)(2) of 46 CFR 162.050–20 references a worksheet, figure 162.050–20, for determining Constituents of Test Fluid C. In response to this commenter's suggestion, we are adding MEPC's Figure 3 to that worksheet, and have inserted the notes as text in that worksheet.

L. Response Time

Commenters raised one issue regarding response time.

Issue 61: One commenter stated that the measuring time in proposed 46 CFR 162.050–33(e) should be changed from 5 seconds to 15 seconds. The commenter also said the proposed 5 seconds would exclude, from future installations, bilge alarms that are already in service and have been proven to provide fail-safe performance.

Response: The Coast Guard disagrees. The purpose of this regulatory change is to increase the performance standards of the equipment. The changes will not require existing equipment MEPC.60(33) to be retrofitted at this time. Previously installed bilge alarms that were approved under the MEPC.60(33) requirements and are in good working order will not have to meet the 5-second response time. However, future installations of these MEPC.60(33)-approved bilge alarms will not be permitted. This is in line with the

requirements of MEPC.107(49). We made no changes in response to this comment.

M. Test Fluid

Commenters raised four issues regarding test fluid.

Issue 62: One commenter stated that separators should be tested with salt-water-mixed test fluids.

Response: Both 46 CFR 162.050–23 (a)(4), and the IMO resolution, paragraph 1.2.7 of Part 1 of the Annex to MEPC.107(49), allow the use of salt water, provided the density of the water used in the tests is no greater than 1.015 at 20° Celsius. We have decided not to mandate testing with salt water as this could materially affect the costs of certification. We made no changes in response to this comment.

Issue 63: One commenter said that turbidity from sources other than oils—including rust and dirt—may fool the bilge alarm into thinking it is seeing oil and, because of this, operators are burdened with removing these other turbidity sources from exposure to the bilge alarm to permit pumping anything over the side.

Response: To ensure alignment with the international requirements, the Coast Guard will require the same three test fluids stipulated in paragraph 1.2.4 of Part 1 of the Annex to MEPC.107(49). Further, we believe that the inclusion of Test Fluid C will account for the equipment's ability to handle particulate matter (including rust) as well as emulsions. We made no changes in response to this comment.

Issue 64: One commenter stated that it is impossible to duplicate emulsion fluid tests in actual sea service. The commenter believes a minimum 6-month trial run in actual service could be part of the rule requirement to obtain equipment certification.

Response: The Coast Guard does not intend to implement a 6-month testing regime for the purpose of certifying PPE. Such testing would be inconsistent with the requirements of MEPC.107(49). Furthermore, Test Fluid C was developed following thorough discussion at IMO and provides a good representation of common bilge water. We made no changes in response to this comment.

Issue 65: One commenter believes that soot in "reasonable representative quantities" should be a component in test fluids, both in the Coast Guard's proposed fluids and MEPC.107(49) fluids.

Response: The Coast Guard disagrees. The constituents of Test Fluid C were developed based on the input of numerous IMO delegations through

discussions over several years. This is believed to be an accurate facsimile of the fluid that may be encountered on a large percentage of the vessels currently in operation. The IMO has received several similar comments and has maintained the same stance regarding changes to it. The Coast Guard concurs with this stance and will maintain the Test Fluid C constituents as they are set out by MEPC.107(49) paragraph 1.2.4. We made no changes in response to this comment.

N. Incorporating MEPC.107(49) by Reference

Commenters raised one issue regarding incorporation by reference.

Issue 66: One commenter believes that incorporating or referencing MEPC.107(49) in the proposed rule will lead to an accurate and thorough understanding of the requirements.

Response: The Coast Guard disagrees because, as discussed in the preamble of the NPRM (70 FR 67067, November 3, 2005), we believe that there are elements of MEPC.107(49) that need clarification. The comments on our proposed rule provide evidence that some aspects of the resolutions require further clarification. We made no changes from the proposed rule based on this comment.

O. Test Report

Commenters raised one issue regarding test reports.

Issue 67: One commenter said that verification of the stability of the Test Fluid C emulsion and other testing parameters must be shown in the test report with documentation to prove conformity.

Response: We believe that a stable emulsion will be established if a lab follows the Test Fluid C preparation requirements under 46 CFR 162.050–20. In response to this comment, we have added a requirement in 46 CFR 162.050–9(a)(6), to provide verification that the lab followed the testing procedures prescribed in 46 CFR subpart 162.050.

P. Cleaning Detergent in Engine Room

Commenters raised two issues regarding cleaning detergent in the engine room.

Issue 68: One commenter believes that any equipment (separators or bilge alarms) should be certified with qualification about what type of cleaners can be used aboard vessels with that product or any inability of that product to handle emulsions. The proposed rule clearly implies that they could not meet MEPC.107(49) testing protocols. Information about system

performance enhancements such as preferred cleaners, etc., belong in their operating manuals, not on their certificates. These qualifications should be removed from the actual certificates and the product's actual certification/testing procedures should be re-verified.

Response: Detergents are generally known to cause emulsions, and the IMO resolutions and corresponding Coast Guard implementing regulations have added an emulsified test fluid to challenge the equipment. However, the Coast Guard does not plan to add this type of information to the approval certificate because unlike older technology represented in the previous standard, MEPC.60(33), under MEPC.107(49) standards, PPE are expected to handle the range of fluids and emulsions that are found in bilges today. Therefore, we are not making a change from the proposed rule based on this comment.

Issue 69: One commenter stated that separators should be required to be insensitive to a host of United States Department of Agriculture (USDA) approved detergents that may be used anywhere in the engine room on a vessel.

Response: With the possibility of emulsified bilge water always present the bilge separator must be capable of separating the oil from the emulsion to produce an effluent with an oil content not exceeding 15 ppm even when detergents are present in the bilge. The bilge separator should therefore be tolerant of a wide range of detergents, but at the same time, as noted in paragraph 1.1.3 of the introduction to the MEPC.107(49) Annex, proper measures should be taken to minimize the presence of cleaning agents in the bilge. As noted above in response to issue 63 regarding turbidity, to ensure alignment with the international requirements, the Coast Guard will require the same three test fluids stipulated in MEPC.107(49). We believe that the inclusion of Test Fluid C will account for the equipment's ability to handle emulsions caused by detergents. We made no changes from the proposed rule based on this comment.

Q. PPE Design

Commenters raised one issue regarding PPE design.

Issue 70: One commenter stated "the absolute absence of any type of standardization of OWS [oily water separator] systems makes the initial investigation confusing, dirty, time consuming and sometimes plain incorrect."

Response: The Coast Guard disagrees. The IMO resolutions and the

corresponding Coast Guard regulations are primarily performance-based in determining the design of a separator. The commenter's suggestion would require prescriptive regulations and could further limit the production of innovative technologies and improvements in the field of separation technology. We made no changes based on this comment.

R. Oil Categories

Commenters raised one issue regarding oil categories.

Issue 71: One commenter suggested that the Coast Guard use its current category of oils based on American Petroleum Institute (API) gravity values and require the laboratory conducting the testing of the oil discharge monitoring equipment (monitoring system) report the values of the crude oils used as described in the Parameters Tolerance column of the Crude Oils table in paragraph 1.2.6 of Part 1 of the Annex to MEPC.108(49). The commenter stated this is in line with the intent of MEPC.108(49) and the Coast Guard's regulation allowing for the onboard calibration of the ODME for the type of crude oil or petroleum product being transported. As an alternative, the commenter requested the Coast Guard provide Standard Reference Material (SRM) crude oil and petroleum product samples to the company for testing purposes or information on where the company can obtain the samples.

Response: We believe that Table 162.050-27(c)—Oil Type and Characteristics in the proposed 46 CFR 162.050-27 accomplishes the goal of this request. Also, 46 CFR 162.050-27(c)(3) allows for the substitution of an oil with similar properties to those listed in table 162.050-27(c). Further, the testing laboratory is required to report the properties of the test oils under 46 CFR 162.050-9(a)(5). We made no changes in response to this comment.

S. Beyond the Scope of This Rulemaking

Commenters raised two issues beyond the scope of this rulemaking.

Issue 72: We received two comments regarding Oil Record Books (ORBs). Of those, one commenter requested that we amend the final rule to mandate training in the proper method of entering entries into the ORB for anyone expected to operate separators. The other comment stated the ORBs are not readily available.

Response: We believe that these requests regarding oil record books are beyond the scope of this rulemaking. This rulemaking seeks to implement the MEPC PPE guidelines and standards being incorporated into MARPOL

Annex I. Oil record books are not referenced in either MEPC.107(49) or MEPC.108(49).

We have forwarded the comment regarding the availability of ORBs to the appropriate office for their consideration. We made no changes to this comment.

Issue 73: We received two comments from the same commenter regarding operating requirements. The commenter stated that it should be a requirement to have onboard a complete set of recommended repair parts for separators. The commenter also said that a complete set (100 percent of installed working elements) of filters, coalescers, filter media, membranes, etc., should be required for separators to assure continued operation in the event of severe fouling.

Response: We feel that this suggestion to require a complete set of repair parts is beyond the scope of the rulemaking. The application for certification, 46 CFR 162.050-5, already requires submission of detailed instructions on maintenance of the unit to be certified. Repair parts are typically only stipulated for certain systems on board that materially affect the safe handling or navigation of the vessel. We made no changes in response to this comment.

T. Changes From Proposed Rule

In 33 CFR part 155, Oil or Hazardous Material Pollution Prevention Regulations for Vessels, we have made the following changes from the proposed rule. As noted in our response to Issue 51, to reflect the requirements of MEPC.107(49) that has been incorporated into MARPOL Annex 1 effective January 1, 2007, we have invited comments on our changes to three paragraphs in §§ 155.350, 155.360, and 155.370, and have delayed the implementation of those three paragraphs pending our review of comments. As discussed in Issues 36 and 37, we also revised § 155.380, and added paragraphs (d), (e) and (f) to that section. Also, we removed references to "bilge monitor" in the section heading and paragraphs (a) and (b) of § 155.380.

In reviewing part 155, we discovered that the IMO Marine Environmental Protection Committee Circular summary of MARPOL 73/78-approved equipment referenced in 33 CFR 155.380(b) no longer exists, so we have changed this reference to include any equipment approved under MARPOL Annex I. Approval of OWS equipment and bilge alarms under MARPOL Annex I is offered as an alternative for U.S. uninspected ships and foreign ships to approval under 46 CFR 162.050. We believe that this revision will

adequately reflect the same level of equipment approval as the previous requirement. Also, we revised the authority citation for the part by relocating the reference to 46 U.S.C. 3703.

In 33 CFR part 157, Rules for the Protection of the Marine Environment Relating to Tank Vessels Carrying Oil in Bulk, we have revised the format of the incorporation by reference section, § 157.02, so that the material approved for incorporation by reference may be more easily associated with the section(s) incorporating this material. As indicated in our response to Issue 1, in part 157 we have removed the term "cargo monitor" to identify the "monitoring system." As noted in Issue 28, we have revised § 157.12c(e). Finally for part 157, in paragraphs (b) and (c) of § 157.12f, we deleted the unnecessary words "at least all" when describing the operations that must be included in a functional test on an oil content meter and a control section of a monitoring system.

In 46 CFR part 162, Engineering Equipment, we made many revisions. We revised the format of the incorporation by reference section, § 162.050-4, so that the incorporated-by-reference-approved material may be more easily associated with the section(s) incorporating this material. Also in that section, we discovered that the International Standards Organization (ISO) 8217 standard incorporated in 46 CFR 162.050-20(a) was revised in 2005. Therefore, we have revised the reference to this ISO standard in § 162.050-4(c)(1). This ISO revision changed the "type" description for the marine residual fuel oil required by § 162.050-20(a)(1). This change is due to ISO's reduction of the temperature at which the viscosity is measured. At the original test temperature of 100° Celsius, this fuel oil had a viscosity of 35 (hence the original name: RMG 35). At the new test temperature of 50° Celsius, this same fuel oil has a viscosity of 380 (hence the new name: RMG 380). The updated ISO 8217 does not affect the "type" description for the marine distillate fuel oil referred to in § 162.050-20(a)(2).

As discussed in our response to Issue 1, we replaced the term "cargo monitor" in part 162 with the term "oil content meter." The following table reflects other changes to part 162 made in response to comments.

For reasons stated in our response to Issue number we revised the following section:
49	162.050-5(a)(6)

For reasons stated in our response to Issue number we revised the following section:
67	162.050–9(a)(6)
57	162.050–17(d)
60	162.050–20
5	162.050–20(b)(3)
43	162.050–21(e)
18	162.050–23(a)(13)
8	162.050–23(b)(1)
3	162.050–27(b) and (c)
10	162.050–27(a)(1)
4	162.050–27(e)(4)
28	162.050–33(f)
35	162.050–33(d)
9	162.050–35(b)(3)
14	162.050–35(g)(3)
16	162.050–35(g)
45	162.050–37(b) and (c)
19 and 26	162.050–39(b) [removed]

Discussion of Interim Rule

We are amending our oil pollution prevention equipment regulations to make them consistent with new IMO guidelines and specifications in resolutions MEPC.107(49) and MEPC.108(49), which are incorporated into MARPOL Annex I regulations 14 (Oil filtering equipment), 18 (Segregated Ballast Tanks), and 31 (Oil discharge monitoring and control system). These revisions will implement Annex I regulations and should reduce the amount of oil discharged from vessels, and eliminate the use of ozone-depleting solvents in equipment tests.

This interim rule will require all vessels replacing or installing oil separators and bilge alarms to install equipment that meets revised standards and it will require newly-constructed vessels carrying oil in bulk to install monitoring systems that meet revised standards. Tests for approval of this equipment have been revised to deal with common bilge contaminants and eliminate the use of ozone-depleting solvents.

We have delayed the implementation of three paragraphs involving equipment installed on or after January 1, 2005. As discussed in our response to Issue 51, paragraph 1.3.1 of resolution MEPC.107(49) was incorporated into MARPOL Annex I on January 1, 2007, and makes the resolution applicable to ships built on or after January 1, 2005, and to ships that install PPE on or after January 1, 2005. This aspect of the revised Annex I was not reflected in our proposed rule.

To implement these incorporated requirements, we have added three paragraphs—33 CFR 155.350(a)(3), 155.360(a)(2), and 155.370(a)(4)—to the interim rule that require vessels built or PPE installed on or after January 1,

2005, to meet the new PPE requirements. As noted above, we seek your comments on these three paragraphs which we have delayed implementing until October 13, 2009, of the interim rule. Based on your comments, we may revise these paragraphs before issuing a final rule.

Since publishing a notice of policy in December 2003 acknowledging the new MARPOL guidelines (68 FR 75603, December 31, 2003), we have approved some systems from PPE manufacturers who, in anticipation of the new MARPOL guidelines, sought Coast Guard approval under testing standards other than those in the current 46 CFR subpart 162.050. As that 2003 notice stated, the Coast Guard may, in its discretion, determine whether alternative standards ensured equivalent performance characteristics.

Systems approved under MEPC.60(33) that are installed on vessels built before January 1, 2005, and are still in good working order will not be affected by this rule. Systems approved before the effective date of this rule using MEPC.107(49) guidelines as the alternative will remain approved. For any system approved after January 1, 2005, using an alternative other than MEPC.107(49), the approval will expire March 17, 2009.

As noted in response to Issue 1, we made some nomenclature changes to better align our terms with those in MEPC.108(49) and in our current pollution certificate requirements. Related to this nomenclature change, we have added paragraph 33 CFR 157.12d(a)(4)(viii)(G) to ensure the control section of the monitoring system is tested in accordance with the vibration testing requirements described in 46 CFR 162.050–37. And we also added paragraph 33 CFR 157.12d(a)(7) to ensure each main component of the monitoring system is designed in accordance with the applicable requirements contained in subchapters F and J.

Compliance with the requirements of this interim rule does not relieve vessel owners and operators of meeting requirements of other applicable laws such as the Federal Water Pollution Control Act, 33 U.S.C. 1251–1387 (also known as the Clean Water Act) or related regulations. This would include compliance with any National Pollutant Discharge Elimination System (NPDES) Vessel General Permit regulations that may be promulgated by the Environmental Protection Agency in response to a court order to vacate an EPA regulation, 40 CFR 122.3(a), which identifies discharges—including most incidental to the normal operation of a

vessel—that do not require NPDES permits. See EPA NPDES General Permits for Discharges Incidental to the Normal Operation of a Vessel notices published June 17, 2008 (73 FR 34296) and December 29, 2008 (73 FR 79473).

VI. Incorporation by Reference

The Director of the Federal Register has approved the material in 33 CFR 157.02 and 46 CFR 162.050–4 for incorporation by reference under 5 U.S.C. 552 and 1 CFR part 51. You may inspect this material at U.S. Coast Guard Headquarters where indicated under **ADDRESSES**. Copies of the material are available from the sources listed in 33 CFR 157.02 and 46 CFR 162.050–4.

VII. Regulatory Analyses

We developed this interim rule after considering numerous statutes and executive orders related to rulemaking. Below we summarize our analyses based on 13 of these statutes or executive orders.

A. Regulatory Planning and Review

Executive Order 12866, “Regulatory Planning and Review,” 58 FR 51735, October 4, 1993, requires a determination whether a regulatory action is “significant” and therefore subject to review by the Office of Management and Budget (OMB) and subject to the requirements of the Executive Order. This rulemaking is not significant under Executive Order 12866 and OMB has not reviewed it.

Public comments on the NPRM are summarized in Part IV of this preamble. We received no public comments and have made no changes that would alter our assessment of impacts in the NPRM. We have found no additional data or information that would change our findings in the NPRM. We have adopted the assessment in the NPRM for this interim rule. See the “Regulatory Evaluation” of the NPRM for the complete analysis. A summary of the assessment follows.

We estimated 176 existing vessels and 46 new vessels annually will be affected by this rule and incur additional costs for installing OWS and bilge alarms.

We estimated the annual costs of the OWS and bilge alarms combined range from \$9,000 to \$19,000, depending on vessel type and size for both existing and new vessels. We estimated non-discounted annual costs for existing vessels at approximately \$2.3 million and approximately \$550,000 for new vessels, or about \$2.9 million combined. We estimated the total 10-year present value cost of the rule to be \$21 million or \$25 million based on a seven or three

percent discount rate (all values rounded).

The benefits of this rule are improved environmental conditions from the use of PPE, which meets higher standards of pollution prevention. The new OWS equipment will better handle the separation of emulsified oils, surfactants, and contaminants from water. There is also a broader range and volume of pollutants that will no longer be released into the environment because of these new standards. See the "Regulatory Evaluation" section of the NPRM for additional details.

B. Small Entities

Under the Regulatory Flexibility Act (5 U.S.C. 601–612), we have considered whether this rule has a significant economic impact on a substantial number of small entities. The term "small entities" comprises small businesses, not-for-profit organizations that are independently owned and operated and are not dominant in their fields, and governmental jurisdictions with populations of less than 50,000.

In the NPRM, we certified under 5 U.S.C. 605(b) that the proposed rule would not have a significant economic impact on a substantial number of small entities. We have found no additional data or information that would change our findings in the NPRM. We have adopted the certification in the NPRM for this interim rule. See the "Small Entity" section of the NPRM for the complete threshold analysis.

Therefore, the Coast Guard certifies, under 5 U.S.C. 605(b), that this interim rule does not have a significant economic impact on a substantial number of small entities. If you think that your business, organization, or governmental jurisdiction qualifies as a small entity and that this interim rule will have a significant economic impact on it, please submit a comment to the Docket Management Facility at the address under **ADDRESSES**. In your comment, explain why you think it qualifies and how and to what degree this rule would economically affect it.

C. Assistance for Small Entities

Under section 213(a) of the Small Business Regulatory Enforcement Fairness Act of 1996 (Pub. L. 104–121), we want to assist small entities in understanding this rule so that they can better evaluate its effects on them and participate in the rulemaking. If the rule affects your small business, organization, or governmental jurisdiction and you have questions concerning its provisions or options for compliance, please consult Mr. Wayne Lundy, Office of Systems Engineering

(CG–5213), Coast Guard, telephone 202–372–1379. The Coast Guard will not retaliate against small entities that question or complain about this rule or any policy or action of the Coast Guard.

D. Collection of Information

This rule calls for no new collection of information under the Paperwork Reduction Act of 1995 (44 U.S.C. 3501–3520). The paperwork burden associated with the manufacture, laboratory testing, approval tests, and marking of pollution prevention equipment is addressed in the existing collection of information, OMB #1625–0035, entitled "Title 46 CFR Subchapter Q: Lifesaving, Electrical and Engineering Equipment; Construction and Materials." The Office of Management and Budget approved this collection of information on March 17, 2006. It will expire after the 3-year approval period ends on March 31, 2009.

E. Federalism

A rule has implications for federalism under Executive Order 13132, Federalism, if it has a substantial direct effect on State or local governments and would either preempt State law or impose a substantial direct cost of compliance on them.

It is well settled that States may not regulate in categories reserved for regulation by the Coast Guard. It is also well settled, now, that all of the categories covered in 46 U.S.C. 3306, 3703, 7101, and 8101 (design, construction, alteration, repair, maintenance, operation, equipping, personnel qualification, and manning of vessels), as well as the reporting of casualties and any other category in which Congress intended the Coast Guard to be the sole source of a vessel's obligations, are within the field foreclosed from regulation by the States. (See the decision of the Supreme Court in the consolidated cases of *United States v. Locke* and *Intertanko v. Locke*, 529 U.S. 89, 120 S.Ct. 1135 (March 6, 2000).)

The pollution prevention equipment regulations promulgated in this rule are within the field foreclosed from regulation by the States, and therefore preemption under E.O. 13132 is not an issue.

F. Unfunded Mandates Reform Act

The Unfunded Mandates Reform Act of 1995 (2 U.S.C. 1531–1538) requires Federal agencies to assess the effects of their discretionary regulatory actions. In particular, the Act addresses actions that may result in the expenditure by a State, local, or tribal government, in the aggregate, or by the private sector of

\$100,000,000 or more in any one year. Though this rule will not result in such an expenditure, we do discuss the effects of this rule elsewhere in this preamble.

G. Taking of Private Property

This rule will not effect a taking of private property or otherwise have taking implications under Executive Order 12630, Governmental Actions and Interference with Constitutionally Protected Property Rights.

H. Civil Justice Reform

This rule meets applicable standards in sections 3(a) and 3(b)(2) of Executive Order 12988, Civil Justice Reform, to minimize litigation, eliminate ambiguity, and reduce burden.

I. Protection of Children

We have analyzed this rule under Executive Order 13045, Protection of Children from Environmental Health Risks and Safety Risks. This rule is not an economically significant rule and does not create an environmental risk to health or risk to safety that may disproportionately affect children.

J. Indian Tribal Governments

This rule does not have tribal implications under Executive Order 13175, Consultation and Coordination with Indian Tribal Governments, because it does not have a substantial direct effect on one or more Indian tribes, on the relationship between the Federal Government and Indian tribes, or on the distribution of power and responsibilities between the Federal Government and Indian tribes.

K. Energy Effects

We have analyzed this rule under Executive Order 13211, Actions Concerning Regulations That Significantly Affect Energy Supply, Distribution, or Use. We have determined that it is not a "significant energy action" under that order because it is not a "significant regulatory action" under Executive Order 12866 and is not likely to have a significant adverse effect on the supply, distribution, or use of energy. The Administrator of the Office of Information and Regulatory Affairs has not designated it as a significant energy action. Therefore, it does not require a Statement of Energy Effects under Executive Order 13211.

L. Technical Standards

The National Technology Transfer and Advancement Act (NTTAA) (15 U.S.C. 272 note) directs agencies to use voluntary consensus standards in their regulatory activities unless the agency

provides Congress, through the Office of Management and Budget, with an explanation of why using these standards would be inconsistent with applicable law or otherwise impractical. Voluntary consensus standards are technical standards (e.g., specifications of materials, performance, design, or operation; test methods; sampling procedures; and related management systems practices) that are developed or adopted by voluntary consensus standards bodies.

This interim rule uses the following consensus standards that are not voluntary standards:

- IMO Assembly Resolution A.393(X)—Recommendation on International Performance and Test Specifications For Oily-Water Separating Equipment and Oil Content Meters;
 - IMO Assembly Resolution A.496(XII)—Guidelines and Specifications for Oil Discharge Monitoring and Control Systems for Oil Tankers;
 - IMO Assembly Resolution A.586(14)—Revised Guidelines and Specifications for Oil Discharge Monitoring and Control Systems for Oil Tankers;
 - IMO Marine Environment Protection Committee Resolution MEPC.13(19)—Guidelines for Plan Approval and Installation Survey of Oil Discharge Monitoring and Control Systems for Oil Tankers and Environmental Testing of Control Sections Thereof;
 - IMO Marine Environment Protection Committee Resolution MEPC.108(49)—Revised Guidelines and Specifications for Oil Discharge Monitoring and Control Systems for Oil Tankers.
 - International Organization for Standardization Standard ISO 8217 (2005) Petroleum products—Fuels (class F)—Specification of marine fuels;
 - International Organization for Standardization Standard ISO 9377-2 (2000), Water Quality—Determination of hydrocarbon oil index—Part 2: Method Using solvent extraction and Gas Chromatography.
- They are used because the United States is party to MARPOL Annex I and we must use these standards to effectively implement MARPOL Annex I regulations. The sections that reference these standards and the locations where these standards are available are listed in 33 CFR 157.02 and 46 CFR 162.050-4.

M. Environment

We have analyzed this rule under Department of Homeland Security

Management Directive 5100.1 and Commandant Instruction M16475.ID, which guide the Coast Guard in complying with the National Environmental Policy Act of 1969 (NEPA) (42 U.S.C. 4321-4370f), and have concluded under the Instruction that there are no factors in this case that would limit the use of a categorical exclusion under section 2.B.2 of the Instruction. Therefore, this rule is categorically excluded, under figure 2-1, paragraph (34)(d), of the Instruction and under section 6(b) of the "Appendix to National Environmental Policy Act: Coast Guard Procedures for Categorical Exclusions, Notice of Final Agency Policy," (67 FR 48243, July 23, 2002), from further environmental documentation. This regulation fits within these categorical exclusions because it concerns equipment approval and carriage requirements and implements regulations designed to protect the environment. An environmental analysis checklist and a categorical exclusion determination are available in the docket where indicated under **ADDRESSES**.

List of Subjects

33 CFR Part 155

Alaska, Hazardous substances, Oil pollution, Reporting and recordkeeping requirements.

33 CFR Part 157

Cargo vessels, Incorporation by reference, Oil pollution, Reporting and recordkeeping requirements.

46 CFR Part 162

Fire prevention, Incorporation by reference, Marine safety, Oil pollution, Reporting and recordkeeping requirements.

- For the reasons discussed in the preamble, the Coast Guard amends 33 CFR parts 155 and 157 and 46 CFR part 162 as follows:

Title 33—Navigation and Navigable Waters

PART 155—OIL OR HAZARDOUS MATERIAL POLLUTION PREVENTION REGULATIONS FOR VESSELS

- 1. Revise the authority citation for part 155 to read as follows:

Authority: 33 U.S.C. 1231, 1321(j); 46 U.S.C. 3703; E.O. 12777, 56 FR 54757, 3 CFR, 1991 Comp., p. 351; Department of Homeland Security Delegation No. 0170.1. Sections 155.100 through 155.130, 150.350 through 155.400, 155.430, 155.440, 155.470, 155.1030(j) and (k), and 155.1065(g) are also issued under 33 U.S.C. 1903(b). Section 155.490 also issued under section 4110(b) of

Pub. L. 101-380. Sections 155.1110 through 155.1150 also issued under 33 U.S.C. 2735.

Note: Additional requirements for vessels carrying oil or hazardous materials are contained in 46 CFR parts 30 through 40, 150, 151, and 153.

- 2. In § 155.350, revise the section heading and add paragraph (a)(3) to read as follows:

§ 155.350 Oily mixture (bilge slops)/fuel oil tank ballast water discharges on oceangoing ships of less than 400 gross tons.

(a) * * *

(3) For equipment installed after 2004 to be approved under paragraph (a)(2) of this section, it must meet current standards in 46 CFR part 162, subpart 162.050, unless the equipment is installed on a ship constructed before 2005 and it would be unreasonable or impracticable to meet those current standards.

* * * * *

- 3. In § 155.360, revise the section heading, redesignate paragraph (a) as (a)(1) and add paragraph (a)(2) to read as follows:

§ 155.360 Oily mixture (bilge slops) discharges on oceangoing ships of 400 gross tons and above but less than 10,000 gross tons, excluding ships that carry ballast water in their fuel oil tanks.

(a)(1) * * *

(2) For equipment installed after 2004 to be approved under paragraph (a)(1) of this section, it must meet current standards in 46 CFR part 162, subpart 162.050, unless the equipment is installed on a ship constructed before 2005 and it would be unreasonable or impracticable to meet those current standards.

* * * * *

- 4. In § 155.370, add paragraph (a)(4) to read as follows:

§ 155.370 Oily mixture (bilge slops)/fuel oil tank ballast water discharges on oceangoing ships of 10,000 gross tons and above and oceangoing ships of 400 gross tons and above that carry ballast water in their fuel oil tanks.

(a) * * *

(4) For equipment installed after 2004 to be approved under paragraph (a) of this section, it must meet current standards in 46 CFR part 162, subpart 162.050, unless the equipment is installed on a ship constructed before 2005 and it would be unreasonable or impracticable to meet those current standards.

* * * * *

- 5. Revise § 155.380 to read as follows:

§ 155.380 Oily water separating equipment and bilge alarm approval standards.

(a) On U.S. inspected ships, oily water separating equipment and bilge alarms must be approved under 46 CFR 162.050.

(b) On U.S. uninspected ships and foreign ships, oily water separating equipment and bilge alarms must be approved under either 46 CFR 162.050 or MARPOL 73/78 Annex I.

Note to § 155.380(b): A copy of Annex I to the International Convention for the Prevention of Pollution from Ships, 1973 as modified by the Protocol of 1978 relating thereto, as amended (MARPOL 73/78) may be purchased from the International Maritime Organization, Publications Section, 4 Albert Embankment, London SE1 75R, United Kingdom, Telex 23588; see also <http://www.imo.org>.

(c) A ship that is required to have a bilge alarm may defer installation and use a previously installed bilge monitor provided the bilge monitor met Coast Guard approval requirements at the time of its installation and it does not allow more than a 15 ppm oil content in water discharge.

(d) The accuracy of the bilge alarms must be checked at IOPP Certificate renewal surveys according to the manufacturer's instructions. Alternatively, the unit may be replaced by a calibrated bilge alarm. The calibration certificate for the bilge alarm, which certifies the date of the last calibration check, should be retained onboard for inspection purposes. The accuracy checks can only be done by the manufacturer or persons authorized by the manufacturer.

(e) Ship staff training must include familiarization in the operation and maintenance of the equipment.

(f) The routine maintenance of the oily water separating equipment and the bilge alarm must be clearly defined by the manufacturer in the associated operating and maintenance manuals. All routine and repair maintenance must be recorded.

PART 157—RULES FOR THE PROTECTION OF THE MARINE ENVIRONMENT RELATING TO TANK VESSELS CARRYING OIL IN BULK

■ 6. Revise the authority citation for part 157 to read as follows:

Authority: 33 U.S.C. 1903; 46 U.S.C. 3703, 3703a (note); Department of Homeland Security Delegation No. 0170.1. Subparts G, H, and I are also issued under section 4115(b), Pub. L. 101–380, 104 Stat. 520; Pub. L. 104–55, 109 Stat. 546.

■ 7. Revise § 157.02 to read as follows:

§ 157.02 Incorporation by reference: Where can I get a copy of the publications mentioned in this part?

(a) Certain material is incorporated by reference into this part with the approval of the Director of the Federal Register under 5 U.S.C. 552(a) and 1 CFR part 51. To enforce any edition other than that specified in this section, the Coast Guard must publish notice of change in the **Federal Register** and the material must be available to the public. All approved material is available for inspection at the National Archives and Records Administration (NARA). For information on the availability of this material at NARA, call 202–741–6030 or go to http://www.archives.gov/federal_register/code_of_federal_regulations/ibr_locations.html. Also, it is available for inspection at the Coast Guard, Systems Engineering Division (CG–5213), Office of Design and Engineering Standards, U.S. Coast Guard, 2100 Second Street, SW., Washington, DC 20593–0001, telephone 202–372–1379, and is available from the sources indicated in this section.

(b) *International Maritime Organization (IMO)*—4 Albert Embankment, London SE1 7SR, United Kingdom.

(1) IMCO Assembly Resolution A.393(X), adopted on 14 November 1977, Recommendation on International Performance and Test Specifications For Oily Water Separating Equipment and Oil Content Meters (“A.393(x)”), incorporation by reference approved for § 157.12.

(2) IMO Assembly Resolution A.496(XII), Adopted on 19 November 1981, Agenda Item 11, Guidelines and Specifications for Oil Discharge Monitoring and Control Systems for Oil Tankers (“A.496(XII)”), incorporation by reference approved for § 157.12.

(3) IMO Assembly Resolution A.586(14), Adopted on 20 November 1985, Agenda item 12, Revised Guidelines and Specifications for Oil Discharge Monitoring and Control Systems for Oil Tankers (“A.586(14)”), incorporation by reference approved for § 157.12.

(4) IMO Marine Environment Protection Committee Resolution MEPC.13 (19), adopted on 9 December 1983, Guidelines for Plan Approval and Installation Survey of Oil Discharge Monitoring and Control Systems for Oil Tankers and Environmental Testing of Control Sections Thereof (“MEPC.13(19)”), incorporation by reference approved for § 157.12.

(5) IMO Marine Environment Protection Committee Resolution MEPC.108(49), Adopted on 18 July

2003, Revised Guidelines and Specifications for Oil Discharge Monitoring and Control Systems for Oil Tankers (“MEPC.108(49)”), incorporation by reference approved for § 157.12.

(6) IMO Assembly Resolution A.601(15), Provision and Display of Manoeuvring Information on Board Ships, Annex sections 1.1, 2.3, 3.1, and 3.2 with appendices, adopted on 19 November 1987 (“A.601(15)”), incorporation by reference approved for § 157.450.

(7) IMO Assembly Resolution A.744(18), Guidelines on the Enhanced Programme of Inspections During Surveys of Bulk Carriers and Oil Tankers, Annex B sections 1.1.3–1.1.4, 1.2–1.3, 2.1, 2.3–2.6, 3–8, and Annexes 1–10 with appendices, adopted 4 November 1993 (“A.744(18)”), incorporation by reference approved for § 157.430.

(8) IMO Assembly Resolution A.751(18), Interim Standards for Ship Manoeuvrability, Annex sections 1.2, 2.3–2.4, 3–4.2, and 5, adopted 4 November 1993 with Explanatory Notes in MSC/Circ. 644 dated 6 June 1994 (“A.751(18)”), incorporation by reference approved for § 157.445.

(c) *Oil Companies International Marine Forum (OCIMF)* 27 Queen Anne's Gate, London, SW1H 9BU, England].

(1) International Safety Guide for Oil Tankers and Terminals, Fourth Edition, Chapters 6, 7, and 10, 1996, incorporation by reference approved for § 157.435.

(2) [Reserved]

§ 157.03 [Amended]

■ 8. In § 157.03, remove the words “cargo monitor” from paragraph (2) of the definition of “clean ballast”, and add, in their place, the words “oil discharge monitoring”.

§ 157.11 [Amended]

■ 9. In § 157.11 (b)(2)(iii), remove the words “a cargo monitor” and add, in their place, the words “an oil content meter”.

■ 10. Revise § 157.12 to read as follows:

§ 157.12 Oil discharge monitoring and control system.

(a) Each vessel must have an oil discharge monitoring and control system (monitoring system) that is designed for use with each type of cargo oil that the vessel carries.

(b) Each oil content meter component of the monitoring system installed on a U.S. vessel must be approved under 46 CFR part 162, subpart 162.050. Each oil content meter component of the

monitoring system installed on a foreign vessel must be approved:

(1) Under 46 CFR part 162, subpart 162.050; or

(2) As meeting IMO Marine Environment Protection Committee resolution MEPC.108(49) by a country that has ratified the MARPOL 73/78. Paragraph 1.2.2 of MEPC.108(49) provides, as to equipment installed in "oil tankers the keels of which are laid, or which are at a similar stage of construction, before January 1, 2005," for alternative compliance with IMO resolutions A.393(X), A.496(XII), MEPC.13(19), and A.586(14). These five resolutions are incorporated by reference (see § 157.02).

(c) Each oil discharge monitoring and control system on a U.S. vessel must be installed in accordance with §§ 157.12b through 157.12g of this part.

■ 11. Add §§ 157.12a through 157.12g to read as follows:

§ 157.12a Definitions.

As used in §§ 157.12a through 157.12g—

Control section means a unit in a monitoring system composed of the items specified in § 157.12d(a)(4)(viii).

Control unit means a device that receives automatic signals of oil content of the effluent ppm, flow rate of discharge m³/hour, ship's speed in knots, ship's position-latitude and longitude, date and time (GMT, Greenwich Mean Time), and status of the overboard discharge control. The control unit makes automatic recordings of data as specified in § 157.12d(h)(2).

Oil discharge monitoring and control system or *monitoring system* means a system that monitors the discharge into the sea of oily ballast or other oil-contaminated water from the cargo tank areas and comprises the items specified in § 157.12d(a)(4).

Overboard discharge control means a device that automatically initiates the sequence to stop the overboard discharge of the effluent in alarm conditions and prevents the discharge throughout the period the alarm condition prevails. The device may be arranged to close the overboard valves or to stop the relevant pumps, as appropriate.

PPM means parts of oil per million parts of water by volume.

Starting interlock means a facility that prevents the initiation of the opening of the discharge valve or the operation of other equivalent arrangements before the monitoring system is fully operational when use of the monitoring system is required by the Convention.

§ 157.12b Implementation requirements.

Oil discharge monitoring and control systems must be fitted to oil tankers to which this subpart applies. A monitoring and control system must employ a control unit and be fitted with a starting interlock and overboard discharge control.

§ 157.12c Construction, maintenance, security, calibration, and training.

(a) The oil discharge monitoring and control system must be designed to ensure that user access is restricted to essential controls. Access beyond these controls must be available for emergency maintenance and temporary repair but must require the breaking of security seals or activation of another device, which indicates an entry to the equipment.

(b) The seals must be of a design that only the manufacturer or the manufacturer's agent can replace the seals or reset the system following inspection and permanent repairs to the equipment.

(c) The accuracy of the monitoring system must be verified during International Oil Pollution Prevention certificate renewal surveys. The calibration certificate certifying date of last calibration check must be retained on board for inspection purposes.

(d) The monitoring system may have several scales as appropriate for its intended use. The recording device fitted to a meter which has more than one scale must indicate the scale which is in use.

(e) Simple means must be provided aboard ship to check on instrument drift, repeatability of the instrument reading, and the ability to re-zero the instrument.

(f) Ship staff training must include familiarization in the operation and the maintenance of the equipment.

(g) The routine maintenance of the monitoring system and troubleshooting procedures must be clearly defined in the Operating and Maintenance Manual. All routine maintenance and repairs must be recorded.

§ 157.12d Technical specifications.

(a) *Oil discharge monitoring and control system.* (1) The monitoring system must be capable of effectively monitoring and controlling the discharge of any effluent into the sea through those overboard discharge outlets permitted by § 157.11 that are necessary to fulfill the operational requirements of the oil tanker.

(2) The discharge of dirty ballast water or other oil-contaminated water from the cargo tank areas into the sea through outlets, which are not

controlled by the monitoring system is prohibited.

(3) The monitoring system must function effectively under all environmental conditions normally encountered by oil tankers, and must be designed and constructed to satisfy the specifications for approval in 46 CFR subpart 162.050. Moreover—

(i) The system must be designed so a discharge of dirty-ballast or other oil-contaminated water from the cargo tank areas cannot take place unless the monitoring system is in the normal operating mode and the relevant sampling point has been selected;

(ii) The system should sample the effluent discharge from a minimum number of discharge outlets and be arranged so that discharge overboard can take place via only one outlet at a time;

(iii) Where it is intended that more than one line be used for simultaneous discharging purposes, one oil content meter, together with a flow meter, must be installed in each discharge line. These instruments must be connected to a common processor; and

(iv) To avoid alarms because of short-term high-oil-concentration signals (spikes) causing indications of high instantaneous rates of discharge, the short-term high ppm signal may be suppressed for a maximum of 10 seconds. Alternatively, the instantaneous rate of discharge may be continuously averaged during the preceding 20 seconds or less as computed from instantaneous ppm values of the oil content meter readings received at intervals not exceeding 5 seconds.

(4) The monitoring system must comprise—

(i) An oil content meter to measure the oil content of the effluent in ppm. The meter must be approved in accordance with the provisions contained in 46 CFR subpart 162.050 and certified to take into account the range of cargoes carried;

(ii) A flow rate indicating system to measure the rate of effluent being discharged into the sea;

(iii) A ship speed indicating device to give the ship's speed in knots;

(iv) A ship position indicating device to give the ship's position-latitude and longitude;

(v) A sampling system to convey a representative sample of the effluent to the oil content meter;

(vi) An overboard discharge control to stop the overboard discharge;

(vii) A starting interlock to prevent the discharge overboard of any effluent unless the monitoring system is fully operational; and

(viii) A control section comprising—

(A) A processor that accepts signals of oil content in the effluent, the effluent flow rate, and the ship's speed, and computes these values into liters of oil discharged per nautical mile and the total quantity of oil discharged;

(B) A means to provide alarms and command signals to the overboard discharge control;

(C) A recording device to provide a record of data required under § 157.12d(h)(2);

(D) A data display to exhibit the current operational data required under § 157.12d(i);

(E) A manual override system to be used in the event of failure of the monitoring system;

(F) A means to provide signals to the starting interlock to prevent the discharge of any effluent before the monitoring system is fully operational; and

(G) The control section of the monitoring system must be tested in accordance with the vibration testing requirements described in 46 CFR 162.050–37.

(5) Each main component of the monitoring system must be fitted with a name plate, properly identifying the component by assembly drawing number, type or model number, and serial number, as appropriate.

(6) The electrical components of the monitoring system that are to be installed in an explosive atmosphere must be in compliance with 46 CFR 162.050–25.

(7) Each main component of the monitoring system must be designed in accordance with the applicable requirements contained in subchapters F and J.

(b) *Sampling system.* (1) Sampling points must be located so relevant samples can be obtained from those outlets used for operational discharges in accordance with paragraph (a) of this section. The sampling probes located in the overboard discharge lines and the piping system connecting the sampling probes to the oil content meter must meet the requirements of this paragraph.

(2) The piping and probes must be—

(i) Of a material resistant to fire, corrosion, and oil; and

(ii) Of adequate strength and properly jointed and supported.

(3) The system must have a stop-valve fitted adjacent to each probe, except that, where the probe is mounted in a cargo line, two stop-valves must be fitted, in series, in the sample line. One of these may be the remote controlled sample selector valve.

(4) Sampling probes must be arranged for easy withdrawal and must, as far as

practicable, be mounted at an accessible location in a vertical section of the discharge line. Should it be necessary to fit sampling probes in a horizontal section of the discharge line it must be ascertained, during the installation survey, that the pipe runs full of liquid at all times during the discharge of the effluent. Sampling probes must normally penetrate inside the discharge pipe to a distance of one quarter the diameter of that pipe.

(5) Means must be provided for cleaning the probes and piping system by the provision of permanent clean water flushing arrangements or an equivalent method. The design of the probes and piping must be such as to minimize their clogging by oil, oily residue, and other matter.

(6) The velocity of the fluid in the piping must be such that, taking into consideration the length of the piping, the overall response time must be as short as possible between an alteration in the mixture being pumped and the alteration in the oil content meter reading. In no case should the response time, including the response time of the oil content meter, be more than 40 seconds.

(7) The location of sampling probes in relation to any point of flow diversion to a slop tank must be selected with regard to the need for sampling the oily water in the recirculation mode.

(8) The arrangements for driving the sampling pump or any other pumps used in the system must account for the safety requirements of the space in which the pump is located. Any bulkhead penetration between a hazardous and a non-hazardous area must be of a design meeting the requirements of 46 CFR 32.60–20 and 46 CFR subpart 111.105.

(9) The flushing arrangement must be such that where necessary it can be utilized for test-running and stabilizing the oil content meter and correcting for zero setting.

(10) Sample water returning to the slop tank must not be allowed to free-fall into the tank. In tankers equipped with an inert gas system, a water seal meeting the requirements of 46 CFR 32.53–10(b) must be arranged in the piping leading to a slop tank.

(11) A valve must be provided for the manual collection of samples from the inlet piping to the oil content meter at a point downstream of any sampling pump.

(c) *Flow rate indicating system.* (1) A flow meter for measuring the rate of discharge must be installed in a vertical section of a discharge line or in any other section of a discharge line as

appropriate, so as to be always filled with the liquid being discharged.

(2) A flow meter must employ an operating principle which is suitable for shipboard use and, where relevant, can be used in large diameter pipes.

(3) A flow meter must be suitable for the full range of flow rates that may be encountered during normal operation. Alternatively, arrangements such as the use of two flow meters of different ranges or a restriction of the operational flow rate range may be employed if necessary to meet this requirement.

(4) The flow meter, as installed, must have an accuracy of ± 10 percent, or better, of the instantaneous rate of discharge throughout the operating range for discharging the effluent.

(5) Any component part of the flow meter in contact with the effluent should be of corrosion-resistant and oil-resistant material of adequate strength.

(6) The design of the flow metering arrangements must account for the safety requirements of the space in which such metering arrangements are located.

(d) *Ship's speed indicating system.* The automatic speed signal required for a monitoring system must be obtained from the ship's speed indicating device by means of a repeater signal. The speed information used may be either speed over the ground or speed through the water, depending upon the speed measuring equipment installed on board.

Note to paragraph (d): See "Recommendation on Performance Standards for Devices to Indicate Speed and Distance," Annex to resolution A.824(19) as amended by resolution MSC.96(72).

(e) *Ship position indicating device.* The ship position indicating device must consist of a receiver for a global navigation satellite system, a terrestrial radio navigation system, or other means suitable for use at all times throughout the intended voyage to establish and update the ship's position by automatic means.

(f) *Overboard discharge control management.* The overboard discharge control must be able to stop the discharge of the effluent into the sea automatically by either closing all relevant overboard discharge valves or stopping all relevant pumps. The discharge control arrangement must be fail-safe so that all effluent discharge is stopped when the monitoring system is not in operation, at alarm conditions, or when the monitoring system fails to function.

(g) *Processor and transmitting device.* (1) The processor of a control section must receive signals from the oil content

meter, the flow rate indicating system and the ship's speed indicating system at time intervals not exceeding 5 seconds and must automatically compute the following:

(i) Instantaneous rate of discharge of oil in liters per nautical mile; and

(ii) Total quantity of oil discharged during the voyage in cubic meters or liters.

(2) When the limits imposed by § 157.37(a)(3) and (4) are exceeded, the processor must provide alarms and provide command signals to the overboard discharge control arrangement, which will cause the discharge of effluent into the sea to stop.

(3) The processor must normally include a device for the continuous generation of time and date information. Alternative arrangements that ensure the automatic and continuous reception of time and date information from an external source may be approved by the Marine Safety Center.

(4) In the event of power failure the processor must retain its memory in respect to computation of the total quantity of oil discharged, time, and date. A printout of data must be obtained when the monitoring system is operating with manual override, but the printout of data is not required if, when the power fails, the monitoring system activates the overboard discharge control to stop the discharge of effluent.

(h) *Recording devices.* (1) The recording device of a control section must include a digital printer, which may be formatted electronically. The recorded parameters must be explicitly identified on the printout. The printout must be legible and must remain so once removed from the recording device and must be retained for at least 3 years.

(2) The data to be automatically recorded must include at least the following:

(i) Instantaneous rate of discharge of oil (liters per nautical mile);

(ii) Instantaneous oil content (ppm);

(iii) The total quantity of oil discharged (cubic meters or liters);

(iv) Time and date (GMT, Greenwich Mean Time);

(v) Ship's speed in knots;

(vi) Ship's position—latitude and longitude;

(vii) Effluent flow rate; (viii) Status of the overboard discharge control or arrangement;

(ix) Oil type selector setting, where applicable;

(x) Alarm condition;

(xi) Failure, including, but not limited to, fault or no flow; and

(xii) Override action, including, but not limited to, manual override, flushing, and calibration. Any

information inserted manually as a result of an override action must be identified as such on the printout.

(3) Data required in paragraph (h)(2) of this section must be printed out or may be stored electronically with printout capability, with the following minimum frequency:

(i) When the discharge is started;

(ii) When the discharge is stopped;

(iii) At intervals of not more than 10 minutes (except when the system is in stand-by mode);

(iv) When an alarm condition develops;

(v) When normal conditions are restored;

(vi) Whenever the computed rate of discharge varies by 10 liters per nautical mile;

(vii) When zero-setting or calibration modes are selected; and

(viii) On manual command.

(4) The recording device must be located in a position easily accessible to the person in charge of the overboard discharge operation.

(i) *Data display.* (1) In addition to the recorded printout, the current data must be visibly displayed and at a minimum contain the following:

(i) Instantaneous rate of discharge of oil (liters per nautical mile);

(ii) Total quantity of oil discharged (cubic meters or liters);

(iii) Instantaneous oil content (ppm);

(iv) Flow rate;

(v) Ship's speed; and

(vi) Status of the overboard discharge control or arrangement.

(2) The data display must be located in a position easily observed by the person in charge of the overboard discharge operation.

(j) *Manually operated alternatives in the event of equipment malfunction.*

Acceptable alternative means of obtaining information in the event of a failure in the monitoring system include the following:

(1) Oil content meter or sampling system: Visual observation of the surface of the water adjacent to the effluent discharge;

(2) Flow meter: Pump discharge characteristics;

(3) Ship's speed indicating device: Main engine rpm;

(4) Processor: Manual calculation and manual recording; and

(5) Overboard discharge control: manual operation of pumps and valves.

(k) *Alarm conditions resulting in the stopping of discharge.* Audio-visual alarms must be activated for any of the following conditions and the monitoring system must be so arranged that the discharge of effluent into the sea is stopped:

(1) Whenever the instantaneous rate of discharge of oil exceeds 30 liters per nautical mile;

(2) When the total quantity of oil discharged reaches 1/30,000 of the previous cargo for new vessels and 1/15,000 for existing vessels; or

(3) In the event of failure of the system's operation, such as:

(i) Power failure;

(ii) Loss of sample;

(iii) Significant failure of the measuring or recording system; or

(iv) When the input of any sensor exceeds the effective capacity of the system.

(l) *Location of alarm indicator.* The alarm indicator of the system must be installed in the cargo control room, where provided, and/or in other places where it will attract immediate attention and action.

§ 157.12e Certificate of approval.

(a) A copy of the certificate of approval for the oil content meters must be carried aboard an oil tanker fitted with such equipment at all times.

(b) A certificate of type approval must be issued for the specific application for which the oil content meter is approved, that is, for crude oil, "black" products, "white" products, or other products or applications as listed on the certificate.

§ 157.12f Workshop functional test requirements.

(a) Each oil content meter and each control section of a monitoring system must be subjected to a functional test on a suitable test bench prior to delivery. The detailed program for a functional test of such equipment must be developed by the manufacturer, taking into account the features and functions of the specific design of equipment. A completed workshop certificate including the delivery test protocol must be received with each unit delivered.

(b) A functional test conducted on an oil content meter must include the following operations:

(1) A check of flow rate, pressure drop, or an equivalent parameter as appropriate;

(2) A check of all alarm functions built into the meter;

(3) A check of all switching functions interconnecting with other parts of the system; and

(4) A check for correct reading at several ppm values on all measurement scales when operated on an oil appropriate for the application of the oil content meter or by an equivalent method.

(c) A functional check conducted on a control section of a monitoring system must include the following operations:

- (1) A check of all alarm functions;
- (2) A check of the correct function of the signal processor and the recording equipment when simulated input signals of ppm, flow rate, and speed are varied;
- (3) A check that the alarm is activated when the input signals are varied to exceed the discharge limits contained in § 157.37(a)(3) and (4);
- (4) A check that a signal is given to the overboard discharge control when alarm conditions are reached; and
- (5) A check that the alarm is activated when each one of the input signals is varied to exceed the capacity of the system.

§ 157.12g Plan approval requirements.

Adequate documentation must be prepared well in advance of the intended installation of a monitoring system and must be submitted to the Marine Safety Center for approval. The following documentation must be submitted:

(a) *A description of the monitoring system.* The description must include a diagram of the pumping and piping arrangements identifying the operational outlets for dirty ballast and oil-contaminated water from the cargo-tank area and compatible with the operational requirements set out in the oil tanker's cargo and ballast handling manuals. Special considerations will be given to installations in oil tankers, which have unusual pumping and piping arrangements.

(b) Equipment manuals, supplied by manufacturers, which must contain details of the major components of the monitoring system.

(c) An operations and technical manual for the complete monitoring system which is proposed to be installed in the oil tanker. This manual must cover the arrangements and operation of the system as a whole and must specifically describe parts of the system, which are not covered by the manufacturer's equipment manuals.

(d) The operations section of the manual must include normal operational procedures and procedures for the discharge of oily water in the event of malfunction of the equipment.

(e) The technical section of the manual must include adequate information (description and diagram of the pumping and piping arrangements of the monitoring system and electrical/electronic wiring diagrams) to enable fault finding and must include instructions for keeping a maintenance record.

(f) A technical installation specification defining, among other things, the location and mounting of

components, arrangements for maintaining the integrity of the boundary between safe and hazardous spaces, and the arrangement of the sample piping, including calculation of the sample response time referred to in § 157.12d(b)(6). The installation must comply with manufacturer's specific installation criteria.

(g) A copy of the certificate of type approval for the oil content meter.

(h) Technical documentation relevant to other main components of the monitoring system. This documentation must include the vibration report for the control section of the monitoring section.

(i) A recommended test and checkout procedure specific to the monitoring system installed. This procedure must specify all the checks to be carried out in a functional test by the installation contractor and must provide guidance for the surveyor when carrying out the onboard survey of the monitoring system and confirming the installation reflects the manufacturer's specific installation criteria.

§ 157.37 [Amended]

■ 12. In § 157.37—

■ a. In the introductory text of paragraph (a)(6), remove the words “a cargo monitor” and add, in their place, the words “an oil discharge monitoring”;

■ b. In paragraph (c), remove the words “cargo monitor” and add, in their place, the words “oil discharge monitoring and control system”;

■ c. In paragraph (d), remove the words “a cargo monitor” and add, in their place, the words “an oil discharge monitoring and control system”.

■ 13. Revise § 157.39(b)(3) to read as follows:

§ 157.39 Machinery space bilges.

* * * * *

(b) * * *

(3) Has in operation an oil discharge monitoring and control system in compliance with § 157.12 and oil separating equipment in compliance with 33 CFR 155.380.

§ 157.43 [Amended]

■ 14. In § 157.43—

■ a. In the introductory text of paragraph (a), remove both occurrences of the words “cargo monitor” and add, in their respective places, the words “oil discharge monitoring and control system”;

■ b. In the introductory text of paragraph (b), remove the words “a cargo monitor” and add, in their place, the words “an oil discharge monitoring and control system”.

Appendix F to Part 157—[Removed and Reserved]

■ Appendix F to Part 157 [Removed and Reserved]

■ 15. Remove and reserve Appendix F to part 157.

Title 46—Shipping

PART 162—ENGINEERING EQUIPMENT

■ 16. Revise the authority citation for part 162 to read as follows:

Authority: 33 U.S.C. 1321(j), 1903; 46 U.S.C. 3306, 3703, 4104, 4302; E.O. 12234, 45 FR 58801, 3 CFR, 1980 Comp., p. 277; E.O. 12777, 56 FR 54757, 3 CFR, 1991 Comp., p. 351; Department of Homeland Security Delegation No. 0170.1.

■ 17. In § 162.050–1, revise paragraph (a)(1) to read as follows:

§ 162.050–1 Scope.

(a) * * *

(1) Procedures for approval of 15 ppm separators, oil content meters, and bilge alarms.

* * * * *

■ 18. Revise § 162.050–3 to read as follows:

§ 162.050–3 Definitions.

As used in this subpart—

15 ppm separator means a separator that is designed to remove enough oil from an oil-water mixture to provide a resulting mixture that has an oil concentration of 15 ppm or less.

Bilge alarm means an instrument that is designed to measure the oil content of oily mixtures from machinery space bilges and fuel oil tanks that carry ballast and activate an alarm at a set concentration limit and record date, time, alarm status, and operating status of the 15 ppm separator.

Independent laboratory means a laboratory that—

(1) Has the equipment and procedures necessary to approve the electrical components described in §§ 162.050–21(b) and 162.050–25(c), or to conduct the test described in § 162.050–37(a); and

(2) Is not owned or controlled by a manufacturer, supplier, or vendor of separators, oil content meters, or bilge alarms.

Oil content meter or *meter* means a component of the oil discharge monitoring and control system that is designed to measure the oil content of cargo residues from cargo tanks and oily mixtures combined with these residues.

PPM means parts per million by volume of oil in water.

Response time means the time elapsed between an alteration in the

sample being supplied to the bilge alarm and the ppm display showing the correct response.

■ 19. Revise § 162.050–4 to read as follows:

§ 162.050–4 Incorporation by reference: Where can I get a copy of the publications mentioned in this part?

(a) Certain material is incorporated by reference into this subpart with the approval of the Director of the Federal Register under 5 U.S.C. 552(a) and 1 CFR part 51. To enforce any edition other than that specified in paragraph (b) of this section, the Coast Guard must publish a notice of change in the **Federal Register** and the material must be available to the public. All approved material is available for inspection at the National Archives and Records Administration (NARA). For information on the availability of this material at NARA, call 202–741–6030 or go to http://www.archives.gov/federal_register/code_of_federal_regulations/ibr_locations.html. Also, it is available for inspection at the Coast Guard, Office of Design and Engineering Standards (CG–521), 2100 Second Street, SW., Washington, DC 20593–0001, telephone 202–372–1379, and is available from the sources indicated in paragraph (b) of this section.

(b) *American Society for Testing and Materials* 100 Barr Harbor Drive, West Conshohocken, PA 19428–2959.

(1) ASTM D2777–98, Standard Practice for Determination of Precision and Bias of Applicable Test Methods of Committee D–19 on Water (“ASTM D2777–98”), incorporation by reference approved for § 162.050–15.

(2) [Reserved]

(c) *International Organization for Standardization (ISO)* 1, rue de Varembé, Case postale 56, CH–1211 Geneva 20, Switzerland (Internet: <http://www.iso.org>):

(1) International Standard ISO 8217 Third edition 2005–11–01, Petroleum products—Fuels (class F)—Specifications of marine fuels (“ISO 8217”), incorporation by reference approved for § 162.050–20.

(2) International Standard ISO 9377–2 First edition 2000–10–15, Water Quality—Determination of hydrocarbon oil index—Part 2: Method using solvent extraction and gas chromatography (“ISO 9377–2”), incorporation by reference approved for § 162.050–39.

(d) *Underwriters Laboratories, Inc., (UL)* 12 Laboratory Drive, Research Triangle Park, NC 27709–3995

(1) Underwriters Laboratories Standard 913 (as revised April 8, 1976),

incorporation by reference approved for §§ 162.050–21, 162.050–25.

(2) [Reserved]

■ 20. In § 162.050–5, revise the introductory text of paragraph (a) and revise paragraph (a)(6) and (a)(8) to read as follows:

§ 162.050–5 Contents of application.

(a) An application for approval of a separator, oil content meter, or a bilge alarm must contain the following information:

* * * * *

(6) An operating and maintenance manual containing detailed and easily understandable instructions on installation, operation, calibration, zeroing, and maintenance of the item.

* * * * *

(8) For each oil content meter, a statement of whether it is to be used with crude oils, refined products, or both.

* * * * *

■ 21. In § 162.050–7—

■ a. In paragraph (e), remove the words “fifty (50)” wherever they appear and add, in their place, the figure “50”;

■ b. Revise paragraph (f) to read as set out below;

■ c. Revise paragraph (h)(2) to read as set out below;

■ d. In paragraph (h)(3), remove “No. 3S” and add, in its place, “No. 3A”;

■ e. In paragraph (h)(4), remove “No.5S” and add, in its place, “No. 5A”, and

■ f. Revise the introductory text of paragraphs (i) and (i)(2) to read as set out below;

■ g. Remove paragraph (j) and redesignate paragraph (k) as paragraph (j);

■ h. Revise newly redesignated paragraphs (j)(2) and (j)(3) to read as follows:

§ 162.050–7 Approval procedures.

* * * * *

(f) The approval tests in this subpart must be performed by a facility designated under § 162.050–15. The facility must also be accepted as an independent laboratory by the Coast Guard under subpart 159.010 of this chapter. The facility must perform each test in accordance with the test conditions prescribed in this subpart for the test, prepare a test report for the item if it completes all of the tests, and send the report with three copies to the Commanding Officer, USCG Marine Safety Center. The applicant may observe the tests. If an item does not complete testing, a new application must be made before retesting.

* * * * *

(h) * * *

(2) The oil content of each sample of separated water effluent taken during approval testing is 15 ppm or less;

* * * * *

(i) An oil content meter is approved under this subpart if—

* * * * *

(2) Each oil content reading recorded during approval testing is ± 10 ppm or ± 10 percent, whichever is greater, of the oil content of the sample influent mixture taken at the time of the reading;

* * * * *

(j) * * *

(2) The oil content of each sample taken during approval testing is 15 ppm ± 5 ppm;

(3) Its response time is five seconds or less; and

* * * * *

■ 22. In § 162.050–9, add paragraph (a)(6) to read as follows:

§ 162.050–9 Test report.

(a) * * *

(6) A statement that the lab followed the testing procedures prescribed in 46 CFR subpart 162.050.

* * * * *

§ 162.050–11 [Amended]

■ 23. In § 162.050–11—

■ a. In paragraph (a), remove the word “monitor” and add, in its place, the words “oil content meter”; and

■ b. In paragraph (b)(8), remove the words “a cargo monitor” and add, in their place, the words “an oil content meter”.

§ 162.050–14 [Removed]

■ 24. Remove § 162.050–14.

■ 25. In § 162.050–15, revise paragraphs (a), (d), (e), (f)(3), and (h) to read as follows:

§ 162.050–15 Designation of facilities.

(a) Each request for designation as a facility authorized to perform approval tests must be submitted to the Commanding Officer, U.S. Coast Guard Marine Safety Center, Engineering Division, 2100 2nd St., SW., Washington, DC 20593–0001.

* * * * *

(d) If the facility meets the requirements in paragraphs (g)(1) through (g)(4) of this section, they must obtain 12 samples containing mixtures of oil in water that are within a 10-to-30 ppm range that can be verified by an independent third-party source mutually acceptable to the applying lab and the Coast Guard prior to verification.

(e) The facility must measure the oil content of each sample using the

method described in § 162.050–39 and report the value of each of the 12 measurements to the Commanding Officer, U.S. Coast Guard Marine Safety Center, Engineering Division, 2100 2nd St., SW., Washington, DC 20593–0001.

(f) * * *
 (3) The absolute value of \bar{X}_d must be smaller than u based on the following analysis of paired observations:

(i) Calculate the value of \bar{X}_d and S_d . This is the mean and standard deviation, respectively, of the differences between the known sample concentrations and the values obtained by the facility with their equipment. The value of \bar{X}_d for the 12 measurements described in paragraph (e) of this section, or for 11 measurements if paragraph (f)(2) of this section applies, must be within the range $1 \leq \bar{X}_d \leq + 1$.

(ii) Determine the appropriate critical value of the Student's t-distribution with (n-1) degrees of freedom for a confidence level of $\alpha = 0.01$. If all 12 samples meet the criteria of paragraph

(f)(1) of this section then (n-1) = 11 and the critical value,

$$t_{1-\frac{\alpha}{2}}$$

is 3.106. If paragraph (f)(2) of this section applies, then (n-1) = 10 and

$$t_{1-\frac{\alpha}{2}} = 3.169.$$

(iii) Compute the value of u , where

$$u = t_{1-\frac{\alpha}{2}} \left(\frac{S_d}{\sqrt{n}} \right),$$

where $n = 12$ if all samples meet the criteria of paragraph b(f)(1) and $n = 11$ if paragraph (f)(2) applies.

(iv) Compare the absolute value of \bar{X}_d to the value of u . If $|\bar{X}_d| < u$, then the facility meets the criteria.

* * * * *
 (h) A facility may not subcontract for approval testing unless previously

authorized by the Coast Guard. A request for authorization to subcontract must be sent to the Commanding Officer, U.S. Coast Guard Marine Safety Center, Engineering Division, 2100 2nd St., SW., Washington, DC 20593–0001.

- 26. In § 162.050–17—
- a. Revise Figure 162.050–17(a) to read as set out below;
- b. Revise paragraphs (b)(1), (b)(2), (c)(1), and (c)(3) as set out below;
- c. Remove the reference to “162.050–17(e)” in paragraph (d), and add, in its place, the reference “162.050–17(d)”; and
- d. Remove Figure 162.050–17(e) and add, in its place, Figure 162.050–17(d) to read as follows:

§ 162.050–17 Separator test rig.

(a) * * *

FIGURE 162.050–17(a)—SEPARATOR TEST RIG

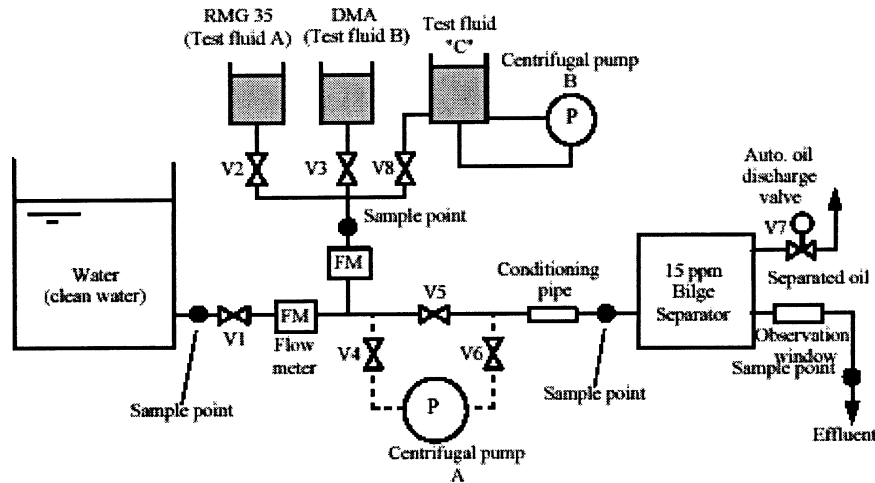

- (b) * * *
- (1) Be a centrifugal pump capable of operating at 1,000 revolutions per minute or more;
 - (2) Have a delivery capacity of at least 1.5 times the maximum throughput at

- which the separator being tested is designed to operate;
- * * * * *
- (c) * * *
- (1) Influent water flows at a Reynolds Number of at least 10,000;

- (2) * * *
- (3) Its length is at least 20 times its inside diameter.
- (d) * * *

FIGURE 162.050–17(d)—SAMPLE POINT

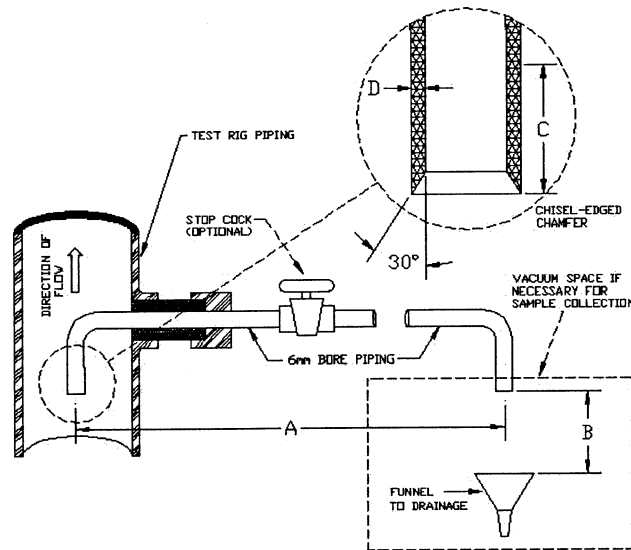

- A DIMENSION A IS NOT GREATER THAN 400 MM
- B HEIGHT B IS LARGE ENOUGH TO INSERT A SAMPLE BOTTLE
- C DISTANCE C IS A STRAIGHT LINE OF NOT LESS THAN 60 MM
- D WIDTH D IS NOT GREATER THAN 2 MM

■ 27. In § 162.050-19—

■ a. In the section heading, remove the word “Monitor” and add, in its place, the words “Oil content meter”;

■ b. In paragraph (a), remove the words “monitors” and “monitor” and add, in

their respective places, the words “oil content meters” and “meter”;

■ c. In paragraph (c), remove the text “one thousand (1,000)” and add, in its place, the figure “1,000”; and

■ d. Revise Figure 162.050-19 to read as follows:

§ 162.050-19 Oil Content Meter and Bilge Alarm Test Rig

* * * * *

FIGURE 162.050-19—MONITOR AND BILGE ALARM TEST RIG

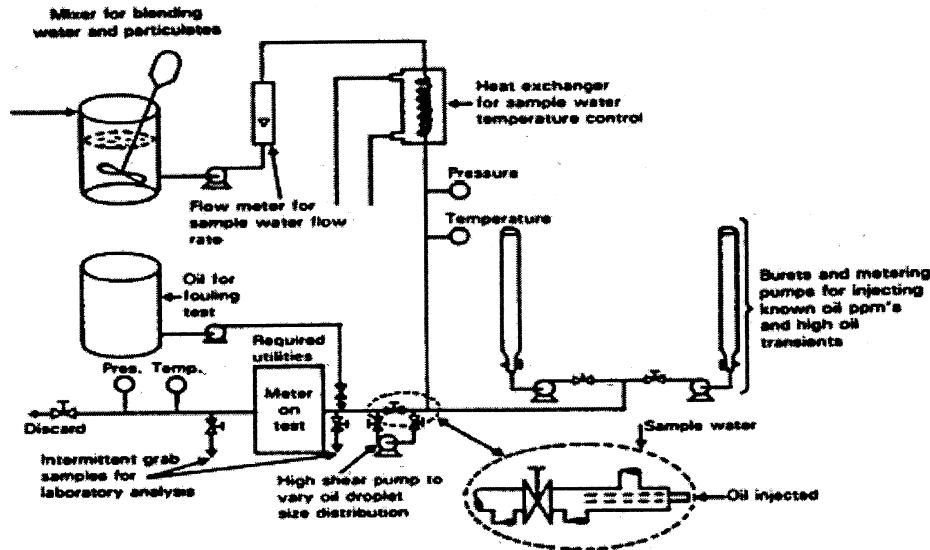

■ 28. Add § 162.050-20 to read as follows:

§ 162.050-20 Separator and bilge alarm test fluids.

(a) Tests required in §§ 162.050-23 and 162.050-35 must be performed using the following three types of test fluids:

(1) Test Fluid A, which is a marine residual fuel oil in accordance with ISO

8217 (incorporated by reference, see § 162.050-4), type RMG 380 (density at 15 °C not less than 980 kg/m³);

(2) Test Fluid B which is a marine distillate fuel oil in accordance with ISO 8217, type DMA (density at 15 °C not less than 830 kg/m³);

(3) Test Fluid C must be a mixture of an oil-in-fresh water emulsion, where 1 kg of the mixture consists of:

- (i) 947.8 g of fresh water;

- (ii) 25.0 g of Test Fluid A;
- (iii) 25.0 g of Test Fluid B;
- (iv) 0.5 g of surfactant (sodium salt of dodecylbenzene sulfonic acid) in the dry form; and
- (v) 1.7 g of iron oxides, a black ferrosferic oxide (Fe₃O₄) with a particle size distribution of which 90 percent is less than 10 microns, the remainder having a maximum particle size of 100 microns.

(b) Test Fluid C must be prepared as needed for § 162.050–23 or § 162.050–35 by using the following procedures:

(1) Measure out 1.2 times the quantity of surfactant required from the WORKSHEET FOR DETERMINING CONSTITUENTS OF TEST FLUID C, see figure 162.050–20;

(2) Mix it with fresh water and stir well in a small container to make a mixture until the surfactant has been thoroughly dissolved, but use no more than the minimum amount of water necessary to make a complete solution;

(3) Fill clean test fluid tank with fresh water with a quantity 1.2 times the volume of the total quantity of water in Test Fluid C needed for the test described in §§ 162.050–23 and 162.050–35;

(4) Operate the centrifugal pump B running at a speed of not less than 3,000 rpm with a flow rate at which the volume of the test fluid has been changed out at least once per minute;

(5) Add the surfactant mixture from paragraph (b)(2) of this section first, followed by oil and suspended solids

(iron oxides) respectively, both 1.2 times of the required amounts, to the fresh water in the tank;

(6) To establish a stable emulsion keep running the centrifugal pump B for one hour and confirm no oil floats on the surface of the test fluid; and

(7) After the one hour stated in paragraph (b)(6) of this section, keep running the centrifugal pump B at reduced speed to approximately 10 percent of original flow rate, until the end of the test.

FIGURE 162.050–20

WORKSHEET FOR DETERMINING CONSTITUENTS OF TEST FLUID C:

1. Determine volumetric flow rate of separator in m³/hr.
2. Determine net volume of fluid needed for testing with fluid C:
 - a. Multiply volumetric flow rate x 3 hours = Net volume
(assumes conditioning time of approximately 30 minutes added to 2-1/2-hour test period)
3. Determine volume of Test Fluid C:
 - a. Multiply net volume * 0.06 = Fluid C volume
4. Determine amounts of constituents:
 - a. Volume of Test Fluid C: 1.2 x Net Volume;
 - b. Volume of fresh water in Test Fluid C: 0.9478 x volume of Test Fluid C;
 - c. Weight of Test Fluid A: 25 x volume of Test Fluid C;
 - d. Weight of Test Fluid B: 25 x volume of Test Fluid C;
 - e. Weight of surfactant: 0.5 x volume of Test Fluid C; and
 - f. Weight of iron oxide 1.7 x volume of Test Fluid C.
 - g. Specifications for tank of Test Fluid .C.

(1) The tank should be of a cylindrical shape, as illustrated in the diagram below. The level of the water should be: $2D \geq H \geq 0.5D$, when preparing Test Fluid C.

(2) Outlet going to centrifugal pump B should be placed at as low a position to the tank as possible.

(3) Inlet to the tank should be fitted at the center of tank bottom so that the mixture flows upward to obtain uniform and stable emulsion.

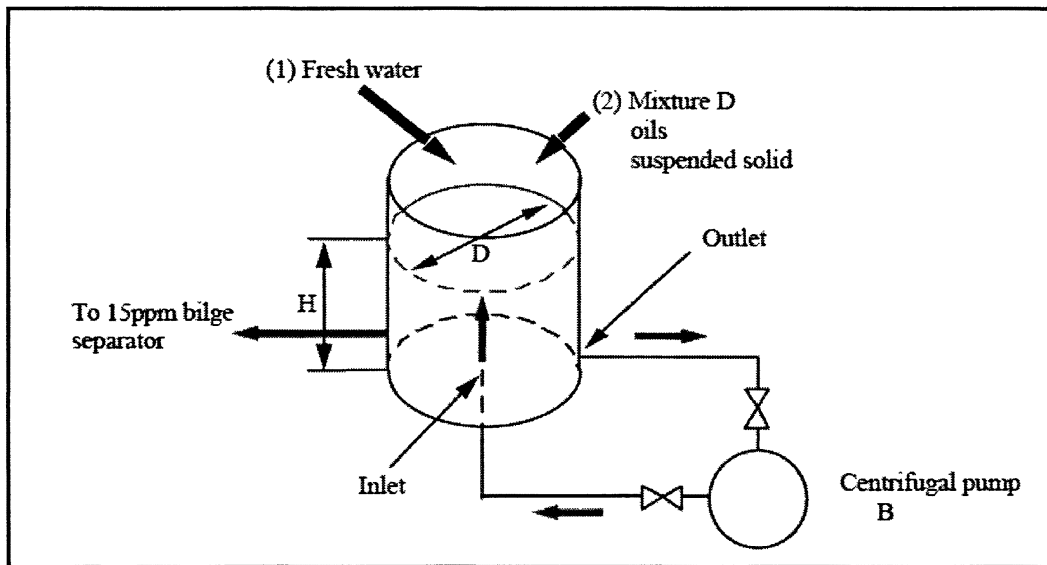

Figure 3 - Tank of Test Fluid "C"

Note:

- (1) The tank should be of a cylindrical shape. The level of the water should be:

$$2D \geq H \geq 0.5D, \text{ when preparing Test Fluid "C".}$$

- (2) Outlet going to centrifugal pump B should be placed at as low a position to the tank as possible.
- (3) Inlet to the tank should be fitted at the center of tank bottom so that the mixture flows upward to obtain uniform and stable emulsion.

Example:

1. Bilge separator is rated at $2\text{m}^3/\text{hr}$;
2. Net volume needed for the test: Volume of test water:
 $2\text{m}^3 \times 3 \text{ hours} = 6\text{m}^3$;
3. Volume test Fluid C: 6 percent of test water = $0.06 \times 6\text{m}^3 = 0.36\text{m}^3$;
4. Actual volume to be prepared:
 - a. Volume of Test Fluid C to be prepared: 1.2 times of the Net Volume of Test Fluid C = $1.2 \times 0.36 = 0.432\text{m}^3$;
 - b. Volume of fresh water in Test Fluid C: $(947.8\text{g}/1000\text{g})$ of Test Fluid C = $0.9478 \times 0.432 = 0.4094\text{m}^3$;
 - c. Weight of Test Fluid A: $(25\text{g}/1000\text{g})$ of Test Fluid C = $25/1000 \times 0.432 \times 1000 = 10.8\text{kg}$;
 - d. Weight of Test Fluid B: $(25\text{g}/1000\text{g})$ of Test Fluid C = $25/1000 \times 0.432 \times 1000 = 10.8\text{kg}$;
 - e. Weight of surfactant: $(0.5\text{g}/1000\text{g})$ of Test Fluid C = $0.5/1000 \times 0.432 \times 1000 = 0.216\text{kg}$; and
 - f. Weight of iron oxide: $(1.7\text{g}/1000\text{g})$ of Test Fluid C = $1.7/1000 \times 0.432 \times 1000 = 0.734\text{kg}$.

§ 162.050–21 [Amended]

- 29. In § 162.050–21—
- a. In paragraph (b), add the words “(incorporated by reference, see § 162.050–4)” after the words “(dated April 8, 1976)”; and
- b. In paragraph (e), remove the text “twenty-four (24)” and add, in its place, the figure “24”, and remove the words “to be installed in an unattended machinery space”.
- 30. In § 162.050–23—
- a. Remove paragraph (a)(2), and redesignate paragraphs (a)(3) through (a)(13) as paragraphs (a)(2) through (a)(12);
- b. Revise redesignated paragraph (a)(4) to read as set out below;

- c. In redesignated paragraph (a)(11), remove the text “one (1)” and add, in its place, the figure “1”;
- d. In redesignated paragraph (a)(12), immediately after the text “Test No. 5”, remove the letter “S” and add, in its place, the letter “A”;
- e. Add paragraph (a)(13) to read as follows; and
- f. Remove paragraphs (b) through (g), and add new paragraphs (b), (c), and (d) to read as follows:

§ 162.050–23 Separator: Approval tests.

- (a) * * *
- * * * * *
- (4) The influent water used in each test must be clean fresh water or clean

fresh water in solution with sodium chloride. In either case, the relative density of the water must be no greater than 1.015 at 20 °C.

* * * * *

(13) If a separator has an integral bilge alarm, the separator must be tested with the bilge alarm installed.

* * * * *

(b) The following tests must be conducted using Test Fluid A:

(1) *Test No. 1A.* The separator is filled with water and started. Next, the separator is fed with pure Test Fluid A for at least 5 minutes and then with a mixture of Test Fluid A and water influent containing Test Fluid A content of between 5,000 and 10,000 ppm until

a steady flow rate at a steady, constant ppm occurs. After the flow rate is steady, the influent is fed to the separator for 30 minutes. Samples of separated water effluent are taken after the first 10 and 20 minutes. At the end of the 30-minute period, the air cock on the test rig is opened and, if necessary, the oil and water supply valves are closed to stop the flow of influent. A sample is then taken of the separated water effluent as the effluent flow ceases.

(2) *Test No. 2A.* Repeat Test No. 1A in paragraph (b)(1) of this section using an influent containing approximately 25 percent oil and 75 percent water. Percentage is on a by volume basis.

(3) *Test No. 3A.* The separator is fed with 100 percent Test Fluid A until Fluid A is discharged at the oil discharge outlet of the separator at essentially the same rate that oil is being fed to the separator. The separator is then fed with 100 percent Test Fluid A for 5 additional minutes. If any oily mixture is discharged from the separated water outlet on the separator during the test, that observation is recorded.

(4) *Test No. 4A.* The separator is fed with water for 15 minutes. Samples of the separated water effluent are taken at the beginning of the test and after the first 10 minutes.

(5) *Test No. 5A.* The separator is operated automatically for 3 hours. During the test, the separator is continuously fed with an influent varying from water to a mixture of 25 percent Test Fluid A in water and back to water every 15 minutes. The Test Fluid A concentration in the influent is varied in at least five equal increments during each 15-minute period and the time intervals between the incremental changes are equal. During the last hour, the separator must be inclined at an angle of 22.5° with the plane of its normal operating position. During the last time increment in which the unit is fed a 25 percent Fluid A mixture, a sample of the separated water effluent is taken. If the separator stops at any time during this test, that observation is recorded.

(c) The following tests must be conducted using Test Fluid B:

(1) *Test No. 1B.* Repeat Test No. 1A in paragraph (b)(1) of this section using Test Fluid B; and

(2) *Test No. 2B.* Repeat Test No. 2A in paragraph (b)(2) of this section using Test Fluid B.

(d) The following tests must be conducted using Test Fluid C: *Test No. 1C.* The separator is fed with a mixture composed of 6 percent Test Fluid C and 94 percent water by volume such that

the emulsified Test Fluid C content is approximately 3,000 ppm in the test water until a steady flow rate occurs. After the flow rate is steady, the influent containing the 6 percent Test Fluid C solution is fed to the separator operating automatically for 3 hours. Samples of separated water effluent are taken at 50 minutes and 100 minutes. At the end of the 3-hour period, the air cock on the test rig is opened and, if necessary, the oil and water supply valves are closed to stop the flow of influent. A sample is then taken of the separated water effluent as the effluent flow ceases.

§ 162.050–25 [Amended]

■ 31. In § 162.050–25—

■ a. In paragraph (c), add the words “(incorporated by reference, see § 162.050–4)” immediately after the words “(dated April 8, 1976)”.

■ b. In paragraph (g), remove the text “twenty (20)” and add, in its place, the figure “20”.

■ 32. Revise § 162.050–27 to read as follows:

§ 162.050–27 Oil content meter: Approval tests.

This section contains requirements that apply to performing each test.

(a) *Test conditions.* (1) The tests and each step in the tests must be carried out in the order described in this section. Each test must be performed without time delay between steps in the test. No maintenance, including replacement of parts, may be performed on the meter during or between the tests described in this section.

(2) A test rig of the type described in § 162.050–19 must be used when performing each test.

(3) Each mixture used during the tests must be prepared by combining oil supplied from the oil injection pipe of the test rig and water supplied from the mixture tank of the test rig. However, if the flow of oil through the oil injection pipe becomes intermittent, oil and water may be combined in the mixture tank to form the mixture.

(4) A mixture may be circulated through a meter only once during testing.

(5) Unless otherwise provided in a specific test, the water used in each test must be clean, fresh water.

(6) The oil used in each test, except Test No. 2 in paragraph (c) of this section, must be Arabian light crude oil.

(7) Each test must be performed at an ambient temperature of between 10 °C and 30 °C.

(8) Unless otherwise provided in a specific test, each test must be performed at the maximum mixture pressure, the maximum flow rate, and

the power supply ratings at which the meter is designed to operate.

(9) The particulate contaminant described in Test No. 5 in paragraph (f) of this section, if not attapulgite, must be of a type that does not lose more than 3 percent of its weight after ignition and must be insoluble in a 500 ppm mixture.

(10) In each test the meter must be operated in accordance with the procedures described in its instructions manual.

(11) Unless otherwise provided in a specific test, the centrifugal pump shown in Figure 162.050–19 in § 162.050–19 must be operated at 1,000 revolutions per minute or more in each test.

(12) Whenever the oil content of a mixture is recorded, a sample of the mixture must also be taken. The oil content of the sample must be measured using the method described in § 162.050–39.

(13) A one-liter sample of each oil to be used in testing must be taken and provided for use in the sample analysis required by § 162.050–39.

(b) *Test No. 1 Calibration and Zero Test.* The meter is calibrated and zeroed to manufacturer's instructions. It is then fed with water for 15 minutes and then with mixtures in the following concentrations: 15 ppm, 50 ppm, 100 ppm, and each additional concentration, in increments of 50 ppm up to the highest oil concentration that can be read on the meter. Each mixture is fed to the meter in the order listed in Table 162.050–27(c) for 15 minutes. Water is fed to the meter for a 15-minute period between each mixture. At the end of each 15-minute period, an oil content reading is obtained and recorded, and a calibration curve must be created.

(c) *Test No. 2 Response to Different Oil Types Test.* (1) If the meter is designed for use with crude oils, it is fed with a mixture of water and the first oil listed in Table 162.050–27(c) at the following concentrations: 15 ppm, 100 ppm, and a concentration that is 90 percent of the highest oil concentration in water that can be read on the meter. Each concentration is fed to the meter in the order listed until a steady reading occurs and is recorded. After each steady reading is recorded, the meter is fed with water for 15 minutes. At the end of each 15-minute period of feeding the meter with water, an oil content reading is again obtained and recorded, and a calibration curve must be created.

(2) The steps described in paragraph (c)(1) of this section are repeated using each of the other oils listed in Table 162.050–27(c). A calibration curve must be created for each oil tested.

TABLE 162.050–27(C)—OIL TYPE AND CHARACTERISTICS

Oil type	Characteristics
Sahara blend crude oil	Density—low. Viscosity—low. Pour point—very low. Producing country—Algeria. General description—mixed base.
Arabian light crude oil	Density—medium. Viscosity—medium. Pour point—low. Producing country—Saudi Arabia. General description—mixed base.
Nigerian medium crude oil	Density—high. Viscosity—medium. Pour point—low. Producing country—Nigeria. General description—naphthenic base.
Bachaquero 17 crude oil	Density—very high. Viscosity—very high. Pour point—low. Producing country—Venezuela. General description—asphaltic base.
Minas crude oil	Density—medium. Viscosity—high. Pour point—very high. Producing country—Indonesia. General description—paraffinic base.
Residual fuel oil	Bunker C or No. 6 Fuel Oil.

(3) If any oil listed in Table 162.050–27(c) is unavailable, an oil with similar properties may be substituted in testing.

(4) If the meter will be used with refined oil products, the steps described in paragraph (c)(1) of this section are performed using each of the following:

- (i) Leaded regular grade automotive gasoline;
- (ii) Unleaded automotive gasoline;
- (iii) Kerosene; and
- (iv) Light diesel or No. 2 fuel oil.

(5) If the meter will be used with category C and D oil-like noxious liquid substances to meet the requirements of 33 CFR 151.41(b), the tests described in paragraphs (c) and (d) of this section are to be performed using the substances for which approval is sought.

(d) *Test No. 3 Response Time Test.* (1) The meter is fed with water, zeroed, and then fed with a 100 ppm mixture. The time at which the meter first detects oil in the mixture, the times of reading 63 ppm and 90 ppm, and the time of reaching the highest steady reading of oil content are recorded. The oil content of the mixture at the highest steady reading is also recorded.

(2) The metering pump is turned off and the time at which the highest reading starts to decrease, the times of reading 37 ppm and 10 ppm, and the time of returning to the lowest steady oil content reading are recorded. The oil content of the mixture at the lowest steady reading is also recorded.

(3) The time interval between first detecting oil in the mixture and reading

63 ppm, and the time interval between the first decrease in the highest reading and reading 37 ppm, are averaged and recorded as the response time for the meter.

(e) *Test No. 4 Oil Fouling and Calibration Shift Test.* (1) The meter is fed with water, zeroed, and then fed with a mixture containing 10 percent oil for one minute. The following must be recorded:

- (i) Time at which the meter first detects oil;
- (ii) Time of reading 15 ppm;
- (iii) Time of reading 100 ppm;
- (iv) Time of exceeding the highest oil concentration that can be read on the meter;
- (v) Time of returning to the highest oil concentration that can be read on the meter;
- (vi) Time of returning to a reading of 100 ppm;
- (vii) Time of returning to a reading of 15 ppm; and
- (viii) Time of returning to the lowest steady oil content reading.

(2) The oil content of the mixture at the lowest steady reading described in paragraph (e)(1)(viii) of this section is recorded.

(3) The meter is fed with water, zeroed, and then fed with oil for 1 minute after which the flow of water is resumed. The times described in paragraph (e)(1) of this section are recorded.

(4) If it is necessary to clean the meter after each oil-fouling test for it to return

to a zero reading, this fact and the time required to clean and recalibrate the meter must be noted and recorded in the test report.

(5) The meter is fed with a 100 ppm mixture until a steady oil content reading is obtained and recorded.

(f) *Test No. 5 Contaminant Test.* (1) The meter is fed with a 15 ppm mixture until a steady oil content reading is obtained and recorded.

(2) The meter is fed with a 15 ppm oil mixture of contaminated water consisting of not less than 270 ppm by weight of the clay mineral attapulgite, or similar contaminant that is stable in both fresh and salt water and 30 ppm by weight of iron oxides. The test contaminant should have a particle size distribution with about 30 percent of 10 microns or less and a maximum particle size of 100 microns. The oil content reading, when steady, is recorded.

(3) Each of the two contaminants will be mixed sequentially in the following manner: the mixing of attapulgite shall be for a period of not less than 15 minutes so that a homogeneous suspension is formed; then, iron oxides will be added for an additional period of not less than 10 minutes. The mixing process should maintain the contaminants in suspension throughout the test period.

(4) The test in paragraph (f)(2) of this section is repeated for 100 and 300 ppm oil mixtures in contaminated water.

(g) *Test No. 6 Air Entrainment Test.*

(1) The meter is fed with a 15 ppm

mixture until a steady oil content reading is obtained and recorded.

(2) Air is injected into the meter test rig before the sample pump or, in the absence of such pump, immediately before any conditioning unit used to prepare the mixture for measurement. Injection must be by needle having an orifice dimension not exceeding 0.5 mm in diameter arranged in line with the sample flow. The quantity of air injected must be 1 percent of the designated flow rate of the sample pump or conditioning unit at the point of injection.

(3) Air must be delivered to the system by direct injection or pump via a suitable measuring device designed to permit a constant controllable flow rate within ± 10 percent of the required rate of injection for an uninterrupted effective test period of not less than 15 minutes.

(4) The oil content reading, when steady, is recorded.

(h) *Test No. 7 Oil Particle Size—Centrifugal Pump Test.* (1) The meter is fed with a 100 ppm mixture until a steady oil content reading is obtained and recorded.

(2) The meter is fed with a 100 ppm mixture that has first passed through the centrifugal pump of the test rig. The pump is run at one-fourth of its design speed. The oil content reading, when steady, is recorded.

(3) The steps described in paragraph (h)(2) of this section are repeated with the pump running at one-half of its design speed and then repeated at its design speed.

(i) *Test No. 8 Temperature Test.* (1) The steps described in paragraph (h)(1) of this section are repeated.

(2) The temperature of the mixture is adjusted to 10 °C and the flow continued until a steady oil content reading is obtained and recorded.

(3) The steps described in paragraph (i)(2) of this section are repeated with the temperature of the mixture at 65 °C or the highest mixture temperature at which the meter is designed to operate, whichever is lower.

(j) *Test No. 9 Sample Pressure or Flow Test.* (1) The steps described in paragraph (h)(1) of this section are repeated.

(2) If the meter has a positive displacement mixture pump, the mixture pressure is lowered to one-half of the meter's maximum design pressure. If the meter has a centrifugal mixture pump, or is not equipped with a mixture pump, the mixture flow rate is reduced to one-half of the meter's design flow rate. The reduced flow rate or mixture pressure is maintained until a steady oil content reading is obtained and recorded.

(3) If the meter has a positive displacement mixture pump, the mixture pressure is increased to twice the meter's design pressure. If the meter has a centrifugal mixture pump or does not have a mixture pump, the mixture flow rate is increased to twice the meter's maximum design flow rate. The increased flow rate or mixture pressure is maintained until a steady oil content reading is obtained and recorded.

(k) *Test No. 10 Shutoff Test.* (1) The steps described in paragraph (h)(1) of this section are repeated.

(2) The water and metering pumps on the test rig are stopped for 8 hours after which the steps described in paragraph (h)(1) of this section are repeated.

(l) *Test No. 11 Supply Voltage Variation Test.* (1) The supply voltage to the meter is increased to 110 percent of its design supply voltage. The meter is then fed a 100 ppm mixture for one hour. At the end of the 1-hour period, an oil content reading is obtained and recorded.

(2) The steps described in paragraph (l)(1) of this section are repeated with the supply voltage to the meter lowered to 90 percent of its design supply voltage.

(3) Upon completing the steps described in paragraph (l)(2) of this section, the supply voltage to the meter is returned to the design rating.

(4) The steps described in paragraphs (l)(1) through (l)(3) of this section are repeated varying each power supply to the meter in the manner prescribed in those steps for supply voltage.

(m) *Test No. 12 Calibration and Zero Drift Test.* (1) The meter is calibrated and zeroed.

(2) The steps described in paragraph (h)(1) of this section are repeated.

(3) A 100 ppm mixture is fed to the meter for 8 hours. At the end of the 8-hour period, an oil content reading is obtained and recorded.

(4) The meter is fed with water until a steady oil content reading is obtained and recorded.

(n) *Test No. 13 Shutdown and Restart Test.* (1) All power to the meter is shutoff for one week. After 1 week the meter is restarted, zeroed, and calibrated.

(2) The meter is fed with a 100 ppm mixture for 1 hour. An oil content reading is then obtained and recorded.

(3) The meter is fed with water for 1 hour. An oil content reading is then obtained and recorded.

(4) The steps described in paragraphs (n)(2) and (n)(3) of this section are repeated three additional times. During the last hour in which the meter is fed with a 100 ppm mixture, the meter is

inclined at an angle of 22.5° with the plane of its normal operating position.

§ 162.050–29 [Removed]

■ 33. Remove § 162.050–29.

§ 162.050–31 [Removed]

■ 34. Remove § 162.050–31.

■ 35. In § 162.050–33—

■ a. Revise paragraph (b) to read as set out below;

■ b. In paragraph (c)(1), remove the two “p.p.m.” abbreviations, and add, in their places, the letters “ppm”; and

■ c. Add new paragraphs (d) through (h) to read as follows:

§ 162.050–33 Bilge alarm: Design specification.

* * * * *

(b) Each bilge alarm must be designed to meet the requirements for an oil content meter in § 162.050–25(b) through (f) and 162.050–25(i), and the requirements in this section.

* * * * *

(d) Each bilge alarm must have a ppm display. Emulsions and/or the type of oil must not affect the ppm display. Calibrating the bilge alarm must not be necessary once installed on board the vessel, however, onboard testing in accordance with the manufacturer's operating instructions is permitted for the purposes of checking instrument drift and repeatability of the instrument reading, as well as the ability to re-zero the instrument. The accuracy of the readings must at all times remain within the limits described in paragraph (c)(1) of this section.

(e) Each bilge alarm must be designed so that it displays each change in oil content of the mixture it is measuring within 5 seconds after the change occurs.

(f) Access to the bilge alarm must require the breaking of a seal, except when—

- (1) Re-zeroing the instrument;
- (2) Checking the instrument drift; or
- (3) Checking the repeatability of the instrument reading.

(g) Each bilge alarm must activate its alarm whenever clean water is used for cleaning or zeroing purposes.

(h) The bilge alarm must record date, time, alarm status, and operating status of the 15 ppm bilge separator. The recording device must also store data for at least 18 months and be able to display or print a protocol. In the event the 15 ppm bilge alarm is replaced, means must be provided to ensure the data recorded remains available on board for 18 months.

■ 36. Revise § 162.050–35 to read as follows:

§ 162.050–35 Bilge alarm: Approval tests.

This section contains requirements that apply to bilge alarms.

(a) *Test Conditions.* (1) Each test must be conducted under the conditions prescribed for meters in § 162.050–27(a)(1) through (a)(5), (a)(7), (a)(8), (a)(10), (a)(11), and (a)(13).

(2) The tests in this section must be performed using test fluids described in § 162.050–20.

(3) The oil content of each sample must be measured using the method described in § 162.050–39.

(b) *Test No. 1A Calibration and Zero Test.* (1) The bilge alarm is calibrated and zeroed to manufacturer's instructions.

(2) It is then fed with water for 15 minutes and then with a mixture of Test Fluid A and water in the following concentrations: 0 ppm, 15 ppm, and the highest oil concentration that can be read on the monitor. A sample of the mixture causing actuation of the alarm is taken. The alarm is then fed with water for 15 minutes.

(3) Repeat steps in paragraphs (b)(2) of this section first using Test Fluid B and then again with Test Fluid C. Collect samples as required in the test for each run of Test Fluid B and Test Fluid C.

(4) If the bilge alarm must be calibrated and re-zeroed between test fluids, this must be noted in the test report.

(c) *Test No. 2A Contaminant Test.* (1) The bilge alarm is fed for 5 minutes with a 10 ppm mixture of Test Fluid B and water. At the end of the 5-minute period an oil content reading is obtained and recorded.

(2) The bilge alarm is then fed for 5 minutes with a 10 ppm mixture of Test Fluid B and water contaminated with a 10 ppm concentration of iron oxide. Any change in the bilge alarm reading during the 5 minutes is recorded.

(3) Repeat steps in paragraphs (c)(1) and (2) of this section using iron oxide concentrations of 50 ppm and 100 ppm.

(4) The bilge alarm is then fed for 5 minutes with a 10 ppm mixture of Test Fluid B and water. At the end of the 5-minute period an oil content reading is obtained and recorded.

(5) The bilge alarm is fed for 5 minutes with a 10 ppm mixture of Test Fluid B and fresh water with 6 percent sodium chloride. Any change in the bilge alarm reading is recorded.

(d) *Test No. 3A Sample Pressure or Flow Test.* (1) The bilge alarm is fed with a mixture of Test Fluid B and water and the test fluid content of the mixture is increased until the bilge alarm actuates. The ppm display is recorded and a sample of the mixture causing actuation of the alarm is taken.

(2) If the alarm has a positive displacement mixture pump, the mixture pressure is reduced to one-half of the alarm's maximum design pressure. If the alarm has a centrifugal mixture pump or is not equipped with a mixture pump, the mixture flow rate is reduced to one-half of the alarm's maximum design flow rate. After reduction of pressure or flow rate, the oil content in the mixture is increased until the alarm actuates. The ppm display is recorded and a sample of the mixture causing actuation of the alarm is taken.

(3) If the alarm has a positive displacement mixture pump, the influent pressure is increased to twice the alarm's minimum design pressure. If the alarm has a centrifugal mixture pump or if the alarm is not equipped with a mixture pump, the influent flow rate is increased to twice the alarm's maximum design flow rate. After increasing the pressure or flow rate, the oil content in the mixture is increased until the alarm actuates. The ppm display is recorded and a sample of the mixture causing actuation is taken.

(e) *Test No. 4A Shutoff Test.* (1) The steps described in paragraph (d)(1) of this section are repeated.

(2) The metering and water pumps of the test rig are stopped for 8 hours with the bilge alarm left turned on with no other changes made.

(3) The metering and water pumps are started and the Test Fluid B content of the mixture is increased until the bilge alarm actuates. A sample of the mixture causing actuation is taken. The bilge alarm ppm display readings before and after the 8-hour period will be recorded.

(f) *Test No. 5A Supply Voltage Variation Test.* (1) The supply voltage to the bilge alarm is raised to 110 percent of its design supply voltage. The bilge alarm is fed with a mixture of Test Fluid B and water and the test fluid content of the mixture is increased until the bilge alarm actuates. The ppm display is recorded and a sample of the mixture causing actuation is taken.

(2) The supply voltage to the alarm is lowered to 90 percent of its design supply voltage. The bilge alarm is fed with a mixture of Test Fluid B and water and the test fluid content of the mixture is increased until the bilge alarm actuates. The ppm display is recorded and a sample of the mixture causing actuation is taken.

(3) Upon completion of the steps described in paragraph (f)(2) of this section, the supply voltage to the alarm is returned to its design value.

(4) The steps described in paragraphs (f)(1) through (f)(3) of this section are repeated varying each other power

supply to the alarm in the manner prescribed in those steps for supply voltage.

(g) *Test No. 6A Calibration and Zero Drift Test.* (1) The steps described in paragraph (b)(1) of this section are repeated and then the steps in paragraph (d)(1) of this section are repeated.

(2) The bilge alarm is fed with a 15 ppm mixture of Test Fluid B and water for eight hours and any calibration drift is recorded. Samples of the mixture must be taken at the beginning of the test and at 2-hour intervals until the completion of the 8-hour period.

(3) Following the steps in paragraph (g)(2) of this section, the bilge alarm must be run on clean, oil-free water only and any zero drift must be recorded.

(h) *Test No. 7A Response Time Test.* (1) The bilge alarm is fed with a 40 ppm mixture of Test Fluid B and water until the bilge alarm actuates. The time of turning on the metering pump of the test rig and the time of alarm actuation are recorded. The flow rate on the flow meter of the test rig is also recorded.

(i) *Test No. 8A Shutdown and Restart Test.* (1) All power to the bilge alarm is shutoff for 1 week. After 1 week the alarm is then restarted, zeroed, and calibrated.

(2) The steps described in paragraph (d)(1) of this section are repeated. Water is then fed to the bilge alarm for 1 hour.

(3) The steps described in paragraph (i)(2) of this section are repeated seven additional times. During the last hour, the alarm must be inclined at an angle of 22.5° with the plane of its normal operating position.

■ 37. In § 162.050–37—

■ a. Revise paragraph (b) to read as set out below; and

■ b. Add paragraph (c) to read as follows:

§ 162.050–37 Vibration test.

* * * * *

(b)(1) Each oil content meter and bilge alarm and each control of a separator must be subjected to continuous sinusoidal vibration in each of the following directions for a 2 hour period in each direction:

- (i) Vertically up and down;
- (ii) Horizontally from side to side; and
- (iii) Horizontally from end to end.

(2) The vibrating frequency must be 80 Hz, except that the vibrating frequency of equipment that has a resonant frequency between 2 Hz and 80 Hz must be the resonant frequency. If the vibrating frequency is between 2 Hz and 13.2 Hz, the displacement amplitude must be ±1 mm. If the vibrating frequency is between 13.2 Hz

and 80 Hz, the acceleration amplitude must be $\pm [(.7)(\text{gravity})]$.

(c) After completion of the tests specified in paragraph (b) of this section, a search must again be made for resonance and any significant change in the vibration pattern must be noted in the test report.

■ 38. Revise § 162.050–39 to read as follows:

§ 162.050–39 Measurement of oil content.

The collection and testing of all samples of oil in water from the required test will be accomplished in accordance with ISO 9377–2 (2000), Water Quality—Determination of hydrocarbon oil index-Part 2: Method Using solvent extraction and Gas Chromatography (incorporated by reference, see § 162.050–4).

Dated: January 12, 2009.

Brian M. Salerno,

Rear Admiral, U.S. Coast Guard, Assistant Commandant for Marine Safety, Security & Stewardship.

[FR Doc. E9–802 Filed 1–15–09; 8:45 am]

BILLING CODE 4910–15–P