

Commission determines that it is not technologically feasible to have this lower limit. Paint, coatings or electroplating may not be considered a barrier that would make the lead content of a product inaccessible to a child.

(b) Section 101(b)(4) of the CPSIA provides that if the Commission determines that it is not technologically feasible for certain electronic devices to comply with the lead limits, the Commission must issue requirements by regulation to eliminate or minimize the potential for exposure to and accessibility of lead in such electronic devices and establish a compliance schedule unless the Commission determines that full compliance is not technologically feasible.

(c) Lead-containing component parts in electronic devices unable to meet the lead limits set forth in section (a) due to technological feasibility are granted exemptions published in the Annex to the European Union Directive 2002/95/EC, as amended through European Union Commission Decision of January 24, 2008, provided that the exemption is based on a functional requirement both for the use of a lead-containing component and for the use of lead in such component, and does not include the crystal glass exemption and any other exemption for decorative or non-functional uses of lead.

(d) Components of electronic devices that are removable or replaceable such as battery packs and light bulbs that are inaccessible when the product is assembled in functional form or are otherwise granted an exemption published in the Annex of European Union Directive 2002/95/EC are not subject to the lead limits in section (a).

(e) Commission staff is directed to reevaluate and report to the Commission on the technological feasibility of compliance with the lead limits in section (a) no less than five years after publication of a final rule in the **Federal Register** on electronic devices.

Dated: January 9, 2009.

Todd A. Stevenson,

Secretary, Consumer Product Safety Commission.

[FR Doc. E9-716 Filed 1-14-09; 8:45 am]

BILLING CODE 6335-01-P

CONSUMER PRODUCT SAFETY COMMISSION

16 CFR Part 1500

Children's Products Containing Lead; Interpretative Rule on Inaccessible Component Parts

AGENCY: Consumer Product Safety Commission.

ACTION: Proposed interpretative rule.

SUMMARY: On August 14, 2008, Congress enacted the Consumer Product Safety Improvement Act of 2008 (CPSIA), Public Law 110-314, 122 Stat. 3016. Section 101(a) of the CPSIA provides for specific lead limits in children's products. Section 101(b)(2) of the CPSIA provides that the lead limits will not apply to any component part of a children's product that is not accessible to a child through normal and reasonably foreseeable use and abuse. Section 101(b)(2)(B) of the CPSIA further directs the Commission to promulgate by August 14, 2009, a rule providing guidance with respect to what product components or classes of components will be considered to be inaccessible. In this document, the Commission is proposing an interpretative rule providing guidance on inaccessible component parts.

DATES: Written comments and submissions in response to this notice must be received by February 17, 2009.

FOR FURTHER INFORMATION CONTACT: Comments should be e-mailed to Sec101InaccessibleRule@cpsc.gov. Comments should be captioned "Section 101 Inaccessible Component Parts." Comments may also be mailed, preferably in five copies, to the Office of the Secretary, Consumer Product Safety Commission, Room 502, 4330 East West Highway, Bethesda, Maryland 20814, or delivered to the same address (telephone (301) 504-7923). Comments also may be filed by facsimile to (301) 504-0127.

SUPPLEMENTARY INFORMATION:

A. Background

The CPSIA provides for specific lead limits in children's products. Section 101(a) of the CPSIA provides that by February 10, 2009, products designed or intended primarily for children 12 and younger may not contain more than 600 parts per million (ppm) of lead. After August 14, 2009, products designed or intended primarily for children 12 and younger cannot contain more than 300 ppm of lead. On August 14, 2011, the limit may be further reduced to 100 ppm, unless the Commission determines that it is not technologically

feasible to have this lower limit. A children's product is defined as a consumer product designed or intended primarily for children 12 years of age or younger under section 235(a) of the CPSIA (to be codified at section 3(a)(2) of the Consumer Product Safety Act). In determining whether a consumer product is primarily intended for a child 12 years of age or younger, the following factors will be considered:

- A statement by the manufacturer about the intended use of such product, including a label on such product if such statement is reasonable.
- Whether the product is represented in its packaging, display, promotion or advertising as appropriate for use by children 12 years of age or younger.
- Whether the product is commonly recognized by consumers as being intended for use by a child 12 years of age or younger.
- The Age Determination Guidelines issued by the Commission in September 2002, and any successor to such guidelines.

Section 101(b)(2) of the CPSIA provides that the lead limits do not apply to component parts of a product that are not accessible to a child. This section specifies that a component part is not accessible if it is not physically exposed by reason of a sealed covering or casing and does not become physically exposed through reasonably foreseeable use and abuse of the product including swallowing, mouthing, breaking, or other children's activities, and the aging of the product, as determined by the Commission. Paint, coatings, or electroplating may not be considered to be a barrier that would render lead in the substrate to be inaccessible to a child. Section 101(b)(2)(B) further provides that the Commission must promulgate a rule providing guidance with respect to what product components or classes of components will be considered to be inaccessible.

To the extent a component part is inaccessible to a child, that component part would be relieved from the testing requirement of section 102 of the CPSIA for purposes of supporting the required certification. Of course even where a component part has been so relieved of the testing requirement, other component parts that are accessible must still meet the statutory lead level requirements, and would be subject to the testing requirement of section 102. The Commission will obtain and test products in the marketplace to assure that this remains the case and will take appropriate enforcement action in situations where the limits are exceeded in accessible parts.

In addition, if the Commission determines that it is not technologically feasible for certain electronic devices to fully comply with the lead limits, section 101(b)(4) of the CPSIA provides that the Commission will issue requirements by regulation to eliminate or minimize the potential for exposure to and accessibility of lead in such electronic devices. A notice of proposed rulemaking on electronic devices is published elsewhere in this **Federal Register**.

On September 26, 2008, the Commission staff requested comments on the CPSC Web site on section 101(b)(2), Exception for Inaccessible Component Parts, and section 101(b)(4), Certain Electronic Devices. In particular, the staff requested comments and information on the identification of any component part of any children's product that currently contains lead in any concentration; whether any children's product currently on the market contains lead-containing component parts that are inaccessible, and the reasons why such component parts are considered inaccessible; and whether test methods or processes exist that are used or may be used to assess the accessibility by children of component parts of products. Comments were due on October 31, 2009. The proposed interpretative rule provides guidance for determining whether lead-containing components of children's products are not accessible to children.

B. Comments

Seventeen comments addressed issues related to accessibility or inaccessibility of lead-containing component parts of children's products, including methods for evaluating accessibility. Three comments discussed fully enclosed parts that should be deemed inaccessible. Four comments asserted that accessibility should refer to exposure to lead, *e.g.*, leaching of lead from the product, not physical accessibility. Two comments suggested that only materials that physically degrade or break down should be considered as resulting in accessibility. Fourteen comments stated that accessible parts should be only those that are ingestible, and refer to testing for small parts. Seven comments stated that the use of tools should not be considered in evaluating accessibility.

The CPSIA defines accessibility as physical exposure to lead-containing component parts. Based on staff's review, the Commission preliminarily determines that an accessible component part of a children's product is one that a child may touch, and an inaccessible component part is one that

is located inside the product that a child cannot touch. The Commission preliminarily accepts staff's recommendation to assess inaccessibility through the use of accessibility probes and use and abuse testing.

Further, based on staff's review, the Commission preliminarily determines that an accessible component part includes a part that a child may touch or place in the mouth, not just a component part that a child might ingest, since exposure to lead may occur during direct mouthing of an object or mouthing of fingers/hands. In addition, a definition of accessibility that refers solely to exposure to lead, *e.g.*, resulting from leaching of lead from a part, or degradation of a material, is not consistent with the definition of accessibility provided in the CPSIA. The Commission also preliminarily finds that the intentional disassembly of products by children through the use of tools should not be considered in evaluating products for accessibility of lead-containing components.

Several comments suggested that the accessibility probes defined in the CPSC's regulations for evaluating accessibility of sharp points or sharp metal or glass edges could be used to evaluate accessibility of lead-containing components. The Commission preliminarily finds that these accessibility probes could be used to determine whether a lead-containing component part of a product is accessible to a child.

Three comments suggested that use and abuse tests could be used to assess whether a product contains ingestible small parts. The Commission preliminarily finds that appropriate use and abuse tests as defined in current CPSC regulations could be part of an evaluation of whether certain component parts of a product become accessible to a child during normal and reasonably foreseeable use and abuse of the product by a child. However, accessibility does not refer only to ingestion of lead-containing components. Rather, the definition of accessibility provided in the CPSIA is physical contact with lead-containing component parts, and the Commission preliminarily finds that this includes touching, placing in the mouth, or ingestion of a part of a product.

C. Proposed Guidance for Inaccessible Component Parts

A component part of a product that contains lead at a level that exceeds the lead limits specified in the CPSIA may be excluded from compliance with the specified limits if the part is not

accessible to a child. The CPSIA specifies that accessibility is defined as physical contact with lead-containing component parts.

Thus, the Commission accepts the staff's recommendation to consider that an accessible component part of a children's product is one that a child may touch, and an inaccessible component part is one that is located inside the product and not capable of being touched by child, whether or not such part is visible to a user of the product. While an inaccessible part may be enclosed in any type of material, *e.g.*, hard or soft plastic, rubber or metal, the CPSIA prohibits the use of surface treatments on a lead-containing component part in the form of paint, coatings, or electroplating as a barrier that would render lead in the substrate to be inaccessible to a child. The Commission seeks comments on whether fabric coverings could be used as a barrier that would make lead within the product inaccessible to a child.

Since a lead-containing component part may be inside a product and not actually fully enclosed by another part of the product, children may have opportunities to contact lead-containing component parts; *e.g.*, they might touch a part with their fingers or tongues. The Commission's proposed approach to addressing section 101(b)(2) is to describe means to test accessibility of potentially lead-containing component parts through evaluation of whether children might touch a lead-containing part.

Currently the Commission's regulations provide that sharp points and sharp metal or glass edges on toys or other articles intended for use by children under age eight years present a potential risk of injury. 16 CFR 1500.48 and 1500.49 provide specific technical requirements for determining accessibility of sharp points or edges through use of accessibility probes specified in these regulations. Both provisions require that a test of accessibility of sharp points or edges shall be applied both before and after use and abuse tests specified in 16 CFR sections 1500.50 through 1500.53. As defined in 16 CFR 1500.48 and 1500.49, an accessible sharp point or edge is present in the product if the result of the test is that any part of the specified portion of the accessibility probe contacts the sharp part.

The ASTM F963 Standard Consumer Safety Specification for Toy Safety (ASTM F963 standard) also includes requirements for accessible sharp points and sharp edges through references to the definitions at 16 CFR 1500.48 and 1500.49. As with the corresponding

regulations, the ASTM F963 standard indicates that accessibility is to be determined both before and after use and abuse tests.

The Commission proposes that the accessibility probes specified for determining accessibility of sharp points or edges be designated as appropriate for determining whether a lead-component part of a product is accessible to a child. An accessible lead-containing component part would be defined as one that contacts any portion of the specified segment of the accessibility probe. An inaccessible lead-containing component part would be defined as one that cannot be

contacted by any portion of the specified segment of the accessibility probe. Under the provisions of the CPSIA, a lead-containing component part is not subject to the lead limits if it is not accessible to a child.

1. Description of Accessibility Probes

16 CFR sections 1500.48 and 1500.49 provide identical technical requirements for two accessibility probes applicable to two categories of children's products, based on the age of the intended consumer. A detailed drawing of the probes is reproduced below as Figure 1.

The two probes differ by size for use with products intended for children aged three years or less (Probe A) or for children up to eight years (Probe B). The probe section of the test fixture is a jointed, three-segment cylindrical piece (the part of the probe on the right side of the illustration in Figure 1) attached to a larger collared section. Under 16 CFR 1500.48, for example, an accessible point is one that can be contacted by any portion forward of the collar. For children aged three years and younger, the probe section is 0.220 inches in diameter with each of the three sections 0.577 inches in length, for a total length of 1.731 inches.

Figure 1. Reproduction of Figure 2 from 16 CFR § 1500.48.

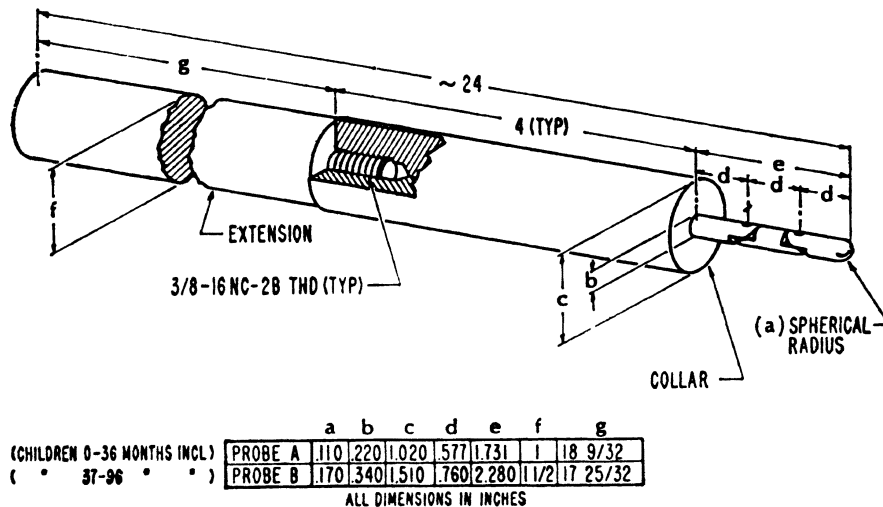

2. Use and Abuse Tests

16 CFR 1500.50 through 1500.53 (excluding the bite tests of 1500.51(c) and 1500.52(c)) provide specific test methods for simulating normal use of toys and other articles intended for use by children as well as the reasonably foreseeable damage or abuse to which the articles may be subjected. The test methods are for use in exposing potential hazards that would result from the normal use or the reasonably foreseeable damage or abuse of such articles intended for children.

The first of these four sections (16 CFR sections 1500.50) describes the objective, general application of the tests, and definitions; the next three sections detail the test methods for articles intended for specified age groups of children: 18 months of age or less, over 18 months but not over 36 months of age, and over 36 months but not over 96 months of age. Products for each of the age groups may be subject to up to five different tests (impact test,

flexure test, torque test, tension test, and compression test) depending on the specifications of the regulations and the characteristics of the product.¹

The Commission preliminarily concludes that these use and abuse tests are appropriate for evaluating whether lead-containing component parts of a product become accessible to a child during normal and reasonably foreseeable use and abuse of the product by a child, since the stated purpose of the tests is to simulate use and damage or abuse of a product by children and to expose potential hazards that might result from use and abuse. However, the Commission is interested in obtaining comment on the effect, if any, of product aging on the use and abuse evaluation.

¹ The staff's toy testing manual, which is on the Commission's Web site at <http://www.cpsc.gov/BUSINFO/testtoys.pdf>, explains in greater detail the sharp point accessibility test and the use and abuse testing currently conducted by Commission staff.

3. Testing Products for Children Aged 12 Years and Under

The existing testing paradigms for accessibility of sharp points and edges are intended for products for use by children in designated age groups up to age eight years. The Commission preliminarily concludes that the application of the current accessibility tests is sufficient for products intended for children older than age eight years, given that the accessibility probes are designed to test whether children's relatively small fingers might enter small holes, gaps, or recesses where they could physically contact certain components, and considering that older children's larger fingers would likely have more limited access to such small holes, gaps, or recesses.

Use and abuse testing is also designated for products for children up to age eight years. While the Commission recognizes that as children age they gain strength and dexterity and participate in a greater range of

activities that could lead to inaccessible components eventually becoming accessible, older children (ages 9 through 12 years) also gain cognitive skills and knowledge that they use to care for and appropriately use their toys and other articles. The Commission preliminarily determines, therefore, that applying the use and abuse tests described for products for children up to age eight years to products for children through age 12 years will appropriately reveal inherent characteristics or possible defects in products that could result in accessibility of components.

Further, the Commission recognizes that as children 12 years of age or younger grow and mature, they become, in many respects, indistinguishable from children older than 12 years, and even adults. Consequently, the Commission preliminarily determines that intentional disassembly or destruction of products by children older than age 8 years by means or knowledge not generally available to younger children should not be considered in evaluating products for accessibility of lead-containing components. For example, accessibility arising from the use of tools, such as a screwdriver, should not be considered in accessibility and use and abuse testing.

On the other hand, testing of products should consider the normal and expected children's interactions with products. For example, children may be expected to operate zippers or snaps, open unsealed and unsecured compartments, or remove unsecured covers. Products with such features should be evaluated for accessibility in all the intended and likely configurations of the product during use by children.

D. Effective Date

The Commission was directed by the CPSIA to promulgate a rule providing guidance on inaccessible component parts by August 14, 2009. Although interpretative rules do not require a particular effective date under the Administrative Procedure Act, 5 U.S.C. 553(d)(2), the Commission recognizes the need for providing the guidance expeditiously. Accordingly, the proposed interpretative rule would take effect upon publication of a final interpretative rule in the **Federal Register**.

E. Request for Comments

Interested persons are invited to submit comment on the proposed rule. Comments should be e-mailed to *Sec101InaccessibleRule@cpsc.gov*.

Comments should be captioned "Section 101 Inaccessible Component Parts." Comments may also be mailed, preferably in five copies, to the Office of the Secretary, Consumer Product Safety Commission, Room 502, 4330 East West Highway, Bethesda, Maryland 20814, or delivered to the same address (telephone (301) 504-7923). Comments also may be filed by facsimile to (301) 504-0127.

F. List of Relevant Documents

Memorandum from Kristina M. Hatlelid, Ph.D., M.P.H., Toxicologist, Directorate for Health Sciences "Consumer Product Safety Improvement Act of 2008 (CPSIA) Exclusions and Exemptions from Compliance with Limits for Lead: Inaccessibility and Certain Electronic Devices." December 2008.

List of Subjects in 16 CFR Part 1500

Consumer protection, Hazardous materials, Hazardous substances, Imports, Infants and children, Labeling, Law enforcement, and Toys.

G. Conclusion

For the reasons stated above, the Commission amends Title 16 of the Code of Federal Regulations as follows:

PART 1500—HAZARDOUS SUBSTANCES AND ARTICLES: ADMINISTRATION AND ENFORCEMENT REGULATIONS

1. The authority for part 1500 is amended to read as follows:

Authority: 15 U.S.C. 1261-1278, 122 Stat. 3016.

2. Add a new § 1500.87 to read as follows:

§ 1500.87 Children's Products Containing Lead: Inaccessible Component Parts.

(a) The Consumer Product Safety Improvement Act (CPSIA) provides for specific lead limits in children's products. Section 101(a) of the CPSIA provides that by February 10, 2009, products designed or intended primarily for children 12 and younger may not contain more than 600 ppm of lead. After August 14, 2009, products designed or intended primarily for children 12 and younger cannot contain more than 300 ppm of lead. On August 14, 2011, the limit may be further reduced to 100 ppm after three years, unless the Commission determines that it is not technologically feasible to have this lower limit. Paint, coatings or electroplating may not be considered a barrier that would make the lead content of a product inaccessible to a child.

(b) Section 101(b)(2) of the CPSIA provides that the lead limits do not apply to component parts of a product that are not accessible to a child. This section specifies that a component part is not accessible if it is not physically exposed by reason of a sealed covering or casing and does not become physically exposed through reasonably foreseeable use and abuse of the product including swallowing, mouthing, breaking, or other children's activities, and the aging of the product, as determined by the Commission. Paint, coatings, or electroplating may not be considered to be a barrier that would render lead in the substrate to be inaccessible to a child.

(c) Section 101(b)(2)(B) of the CPSIA directs the Commission to promulgate by August 14, 2009, this interpretative rule to provide guidance with respect to what product components or classes of components will be considered to be inaccessible.

(d) The accessibility probes specified for sharp points or edges under the Commission's regulations at 16 CFR 1500.48-1500.49 will be used to assess the accessibility of lead-component parts of a children's product. A lead-containing component part would be considered accessible if it contacts any portion of the specified segment of the accessibility probe. A lead-containing component part would be considered inaccessible if it cannot be contacted by any portion of the specified segment of the accessibility probe.

(e) The use and abuse tests set forth under the Commission's regulations at 16 CFR 1500.50-1500.53 (excluding the bite tests of 1500.51(c) and 1500.52(c)) will be used to evaluate accessibility of lead-containing component parts of a children's product as a result of normal and reasonably foreseeable use and abuse of the product by children that are 18 months of age or less, over 18 months but not over 36 months of age, and over 36 months but not over 96 months of age.

(f) The use and abuse tests set forth under the Commission's regulations at 16 CFR 1500.50-1500.53 (excluding the bite tests of 1500.51(c) and 1500.52(c)) intended for children aged 37-96 months will be used to evaluate accessibility of lead-containing component parts of a children's product as a result of normal and reasonably foreseeable use and abuse of the product by a child through 12 years of age.

(g) The intentional disassembly or destruction of products by children older than age 8 years by means or knowledge not generally available to younger children, including use of tools, will not be considered in evaluating

products for accessibility of lead-containing components.

Dated: January 9, 2009.

Todd A. Stevenson,

Secretary, Consumer Product Safety Commission.

[FR Doc. E9-717 Filed 1-14-09; 8:45 am]

BILLING CODE 6335-01-P

DEPARTMENT OF ENERGY

Federal Energy Regulatory Commission

18 CFR Part 284

[Docket No. RM09-2-000]

Contract Reporting Requirements of Intrastate Natural Gas Companies

January 7, 2009.

AGENCY: Federal Energy Regulatory Commission, DOE.

ACTION: Notice of Inquiry: extension of comment deadline.

SUMMARY: On November 20, 2008, the Federal Energy Regulatory Commission issued a Notice of Inquiry to consider whether to revise its contract reporting requirements for those natural gas pipelines that fall under the Commission's jurisdiction pursuant to section 311 of the Natural Gas Policy Act of 1978 or section 1(c) of the Natural Gas Act (November 28, 2008, 73 FR 72395). The deadline for filing comments is being extended at the request of the Texas Pipeline Association.

Comment Date: Comments are due on or before February 13, 2009.

ADDRESSES: You may submit comments on the Notice of Inquiry, identified by Docket No. RM09-2-000, by one of the following methods:

- *Agency Web site:* <http://www.ferc.gov>. Follow instructions for submitting comments via the eFiling link found in the Comment Procedures Section of the preamble.

- *Mail:* Commenters unable to file comments electronically must mail or hand deliver an original and 14 copies of their comments to the Federal Energy Regulatory Commission, Secretary of the Commission, 888 First Street, NE., Washington, DC 20426.

FOR FURTHER INFORMATION CONTACT:

Vince Mareino (Legal Information),
Office of the General Counsel, Federal Energy Regulatory Commission, 888 First Street, NE., Washington, DC 20426, (202) 502-6167,
Vince.Mareino@ferc.gov.

Brian White (Technical Information),
Office of Energy Markets Regulation,

Federal Energy Regulatory Commission, 888 First Street, NE., Washington, DC 20426, (202) 502-8332, Brian.White@ferc.gov.

SUPPLEMENTARY INFORMATION:

Notice of Extension of Time

On December 19, 2008, the Texas Pipeline Association (TPA) filed a motion for an extension of time to file comments in response to the Commission's Notice of Inquiry issued November 20, 2008, in the above-referenced proceeding. *Contract Reporting Requirements of Intrastate Natural Gas Companies*, 125 FERC ¶ 61,190 (2008) (NOI). The motion states that because of the potential impact of the NOI on TPA and its members and because of the press of other business and the intervening holidays, additional time is needed to file responsive comments.

Upon consideration, notice is hereby given that an extension of time for filing comments on the Commission's NOI is granted to and including February 13, 2009, as requested by TPA.

Kimberly D. Bose,

Secretary.

[FR Doc. E9-394 Filed 1-14-09; 8:45 am]

BILLING CODE 6717-01-P

DEPARTMENT OF HEALTH AND HUMAN SERVICES

Food and Drug Administration

21 CFR Part 131

[Docket No. FDA-2000-P-0126] (formerly Docket No. 2000P-0685)

Milk and Cream Products and Yogurt Products; Proposal to Revoke the Standards for Lowfat Yogurt and Nonfat Yogurt and to Amend the Standard for Yogurt

AGENCY: Food and Drug Administration, HHS.

ACTION: Proposed rule.

SUMMARY: The Food and Drug Administration (FDA) is proposing to revoke its regulations on the standards of identity for lowfat yogurt and nonfat yogurt and amend the standard of identity for yogurt in numerous respects. This action is in response, in part, to a citizen petition submitted by the National Yogurt Association (the NYA). FDA tentatively concludes that this action will promote honesty and fair dealing in the interest of consumers and, to the extent practicable, will achieve consistency with existing

international standards of identity for yogurt.

DATES: Submit comments by March 31, 2009.

ADDRESSES: You may submit comments, identified by Docket No. FDA-2000-P-0126, by any of the following methods:
Electronic Submissions

Submit electronic comments in the following ways:

- Federal eRulemaking Portal: <http://www.regulations.gov>. Follow the instructions for submitting comments.

Written Submissions

Submit written submissions in the following ways:

- FAX: 301-827-6870.
- Mail/Hand delivery/Courier (for paper, disk, or CD-ROM submissions): Division of Dockets Management (HFA-305), Food and Drug Administration, 5630 Fishers Lane, rm. 1061, Rockville, MD 20852.

To ensure more timely processing of comments, FDA is no longer accepting comments submitted to the agency by e-mail. FDA encourages you to continue to submit electronic comments by using the Federal eRulemaking Portal, as described previously, in the **ADDRESSES** portion of this document under *Electronic Submissions*.

Instructions: All submissions received must include the agency name and docket number for this rulemaking. All comments received may be posted without change to <http://www.regulations.gov>, including any personal information provided. For additional information on submitting comments, see the "Comments" heading of the **SUPPLEMENTARY INFORMATION** section of this document.

Docket: For access to the docket to read background documents or comments received, go to <http://www.regulations.gov> and insert the docket number, found in brackets in the heading of this document, into the "Search" box and follow the prompts and/or go to the Division of Dockets Management, 5630 Fishers Lane, rm. 1061, Rockville, MD 20852.

FOR FURTHER INFORMATION CONTACT: Ritu Nalubola, Center for Food Safety and Applied Nutrition (HFS-820), Food and Drug Administration, 5100 Paint Branch Pkwy., College Park, MD 20740, 301-436-2371.

SUPPLEMENTARY INFORMATION:

Table of Contents

- I. Background
 - A. Current Standards of Identity for Yogurt, Lowfat Yogurt, and Nonfat Yogurt
 - B. The National Yogurt Association Petition