

Administrator has determined that prior notice and opportunity for public comment are contrary to the public interest and that there is good cause under 5 U.S.C. 553 for making this action effective less than 30 days after publication in the **Federal Register**.

We will consider comments we receive during the comment period for this interim rule (see **DATES** above). After the comment period closes, we will publish another document in the **Federal Register**. The document will include a discussion of any comments we receive and any amendments we are making to the rule.

Executive Order 12866 and Regulatory Flexibility Act

This rule has been reviewed under Executive Order 12866. For this action, the Office of Management and Budget has waived its review under Executive Order 12866.

Brucellosis is a contagious, costly disease of ruminants and other animals that can also affect humans. It is mainly a threat to cattle, bison, and swine. The disease causes decreased milk production, weight loss in animals, loss of young, infertility, and lameness. There is no known effective treatment.

The State of Texas has met all the requirements for obtaining Class Free status as outlined in the definition of "Class Free State or area" in § 78.1 of the regulations. The interim rule upgrades the brucellosis status of Texas from Class A to Class Free. Cattle and bison that are to be moved interstate from Class A States, except those moving directly to slaughter or to quarantined feedlots, must be tested before they are eligible for movement. Attaining Class Free status allows producers in Texas to forgo the cost of this test.

Brucellosis testing, including veterinary fees and handling expenses, costs about \$7.50 to \$15 per test. The expenses forgone as a result of this reclassification in status will be insignificant to cattle owners in Texas. There were 14 million cattle and calves in Texas in 2002. Of this total, 50.7 percent were breeding animals; the rest were composed of non-breeding animals in and outside feedlots. About 9.2 percent of cattle and calves in Texas are moved interstate.¹ The average per head value of cattle in Texas was \$790 in 2006.² Thus, the cost of testing

represents between 0.9 and 1.8 percent of the average value of the animals sold. The upgrading of the State to brucellosis Class Free status will result in a small savings for those entities moving cattle interstate other than directly to slaughter or to quarantined feeding.

We expect that the majority of cattle and calves operations that will be affected by the interim rule are small entities. Under guidelines established by the Small Business Administration (SBA), an enterprise producing cattle and calves is considered small if it has annual receipts of \$750,000 or less.³ There were 125,518 farms with sales of cattle and calves in Texas in 2002.⁴ Over 99 percent of these farms had annual receipts not exceeding \$750,000. These small farms had average sales of \$17,700.

The interim rule will benefit producers that sell cattle and calves out of State for breeding and feeding purposes. However, the savings from the forgone testing will be very small, estimated to be between approximately 1 and 2 percent of the value of the animals sold.

Under these circumstances, the Administrator of the Animal and Plant Health Inspection Service has determined that this action will not have a significant economic impact on a substantial number of small entities.

Executive Order 12372

This program/activity is listed in the Catalog of Federal Domestic Assistance under No. 10.025 and is subject to Executive Order 12372, which requires intergovernmental consultation with State and local officials. (See 7 CFR part 3015, subpart V.)

Executive Order 12988

This interim rule has been reviewed under Executive Order 12988, Civil Justice Reform. This rule: (1) Preempts all State and local laws and regulations that are in conflict with this rule; (2) has no retroactive effect; and (3) does not require administrative proceedings before parties may file suit in court challenging this rule.

Paperwork Reduction Act

This interim rule contains no information collection or recordkeeping requirements under the Paperwork Reduction Act of 1995 (44 U.S.C. 3501 *et seq.*).

List of Subjects in 9 CFR Part 78

Animal diseases, Bison, Cattle, Hogs, Quarantine, Reporting and

recordkeeping requirements, Transportation.

■ Accordingly, we are amending 9 CFR part 78 as follows:

PART 78—BRUCELLOSIS

■ 1. The authority citation for part 78 continues to read as follows:

Authority: 7 U.S.C. 8301–8317; 7 CFR 2.22, 2.80, and 371.4.

§ 78.41 [Amended]

■ 2. Section 78.41 is amended as follows:

■ a. In paragraph (a), by adding the word "Texas," after the word "Tennessee,".

■ b. In paragraph (b), by removing the word "Texas" and adding the word "None" in its place.

Done in Washington, DC, this 28th day of January 2008.

Kevin Shea,

Acting Administrator, Animal and Plant Health Inspection Service.

[FR Doc. E8–1853 Filed 1–31–08; 8:45 am]

BILLING CODE 3410–34–P

DEPARTMENT OF TRANSPORTATION

Federal Aviation Administration

14 CFR Part 39

[Docket No. FAA–2008–0101; Directorate Identifier 2007–SW–76–AD; Amendment 39–15357; AD 2007–26–51]

RIN 2120–AA64

Airworthiness Directives; Eurocopter Deutschland GmbH Model EC135 Helicopters

AGENCY: Federal Aviation Administration, DOT.

ACTION: Final rule; request for comments.

SUMMARY: This document publishes in the **Federal Register** an amendment adopting Airworthiness Directive (AD) 2007–26–51, which was sent previously to all known U.S. owners and operators of Eurocopter Deutschland GmbH (Eurocopter) Model EC135 helicopters by individual letters. This AD requires, within 5 hours time-in-service (TIS), inspecting the tail rotor control rod (control rod) and adjoining ball pivot and replacing any unairworthy parts before further flight. This amendment is prompted by a report of a fatal accident involving the failure of a control rod. The actions specified by this AD are intended to prevent failure of a control rod and subsequent loss of control of the helicopter.

¹Dennis A. Shields and Kenneth H. Mathews, Jr., Interstate Livestock Movements, U.S. Department of Agriculture (USDA)/Economic Research Service, June 2003.

²USDA/National Agricultural Statistics Service (NASS), Meat Animals Production, Disposition, and Income 2006 Summary, April 2007.

³SBA, Table of Small Business Size Standards, effective October 1, 2007.

⁴USDA/NASS, 2002 Census of Agriculture.

DATES: Effective February 19, 2008, to all persons except those persons to whom it was made immediately effective by Emergency AD 2007–26–51, issued on December 14, 2007, which contained the requirements of this amendment.

Comments for inclusion in the Rules Docket must be received on or before April 1, 2008.

ADDRESSES: Use one of the following addresses to submit comments on this AD:

- *Federal eRulemaking Portal:* Go to <http://www.regulations.gov>. Follow the instructions for submitting comments.
- *Fax:* 202–493–2251.
- *Mail:* U.S. Department of Transportation, Docket Operations, M–30, West Building Ground Floor, Room W12–140, 1200 New Jersey Avenue, SE., Washington, DC 20590.
- *Hand Delivery:* U.S. Department of Transportation, Docket Operations, M–30, West Building Ground Floor, Room W12–140, 1200 New Jersey Avenue, SE., Washington, DC 20590, between 9 a.m. and 5 p.m., Monday through Friday, except Federal holidays.

You may get the service information identified in this AD from American Eurocopter Corporation, 2701 Forum Drive, Grand Prairie, Texas 75053–4005, telephone (972) 641–3460, fax (972) 641–3527.

Examining the Docket: You may examine the docket that contains the AD, any comments, and other information on the Internet at <http://www.regulations.gov>, or in person at the Docket Operations office between 9 a.m. and 5 p.m., Monday through Friday, except Federal holidays. The Docket Operations office (telephone (800) 647–5527) is located in Room W12–140 on the ground floor of the West Building at the street address stated in the **ADDRESSES** section. Comments will be available in the AD docket shortly after receipt.

FOR FURTHER INFORMATION CONTACT: Chinh Vuong, Aviation Safety Engineer, FAA, Rotorcraft Directorate, Safety Management Group, Fort Worth, Texas 76193–0111, telephone (817) 222–5116, fax (817) 222–5961.

SUPPLEMENTARY INFORMATION: On December 14, 2007, the FAA issued Emergency AD 2007–26–51 for Eurocopter Model EC135 helicopters, which requires, within 5 hours TIS, inspecting the control rod and adjoining ball pivot and replacing any unairworthy parts before further flight. That action was prompted by a report of a fatal accident involving the failure of a control rod. This condition, if not corrected, could result in the failure of

a control rod and subsequent loss of control of the helicopter.

The European Aviation Safety Agency (EASA), which is the Technical Agent for the Member States of the European Community, notified us that an unsafe condition may exist on Eurocopter EC135 and EC635 helicopters. EASA advises that an accident recently occurred with an EC135 helicopter in Japan. Preliminary investigation results indicate that the helicopter loss of control was due to the failure of the control rod.

Eurocopter has issued Alert Service Bulletin No. EC135–67A–017, dated December 13, 2007 (ASB), which specifies procedures for checking the attachment hardware on the control rod for a tight fit, checking the ball pivot for damage and freedom of movement, and replacing any damaged part before the next flight. EASA classified this ASB as mandatory and issued EASA AD No. 2007–0301–E, dated December 13, 2007, to ensure the continued airworthiness of these helicopters in the Federal Republic of Germany.

These helicopter models are manufactured in the Federal Republic of Germany and are type certificated for operation in the United States under the provisions of 14 CFR 21.29 and the applicable bilateral agreement. Pursuant to the applicable bilateral agreement, EASA has kept the FAA informed of the situation. The FAA has examined the findings of EASA, reviewed all available information, and determined that AD action is necessary for products of this type design that are certificated for operation in the United States.

Since the unsafe condition described is likely to exist or develop on other Eurocopter Model EC135 helicopters of the same type design, the FAA issued Emergency AD 2007–26–51 to prevent failure of a control rod and subsequent loss of control of the helicopter. The AD requires, within 5 hours TIS, inspecting the control rod and adjoining ball pivot and replacing any unairworthy parts before further flight. The short compliance time involved is required because the previously described critical unsafe condition can adversely affect the controllability of the helicopter. Therefore, within 5 hours TIS, inspecting the control rod and adjoining ball pivot and replacing any unairworthy parts before further flight are required, and this AD must be issued immediately.

Since it was found that immediate corrective action was required, notice and opportunity for prior public comment thereon were impracticable and contrary to the public interest, and good cause existed to make the AD

effective immediately by individual letters issued on December 14, 2007, to all known U.S. owners and operators of Eurocopter Model EC135 helicopters. These conditions still exist, and the AD is hereby published in the **Federal Register** as an amendment to 14 CFR 39.13 to make it effective to all persons.

The FAA estimates that this AD will affect 163 helicopters of U.S. registry. We estimate 1 work hour to inspect the control rod and ball pivot and 3 work hours to replace a control rod or ball pivot, if necessary, at an average labor rate of \$80 per work hour. Required parts will cost \$400 for the control rod and \$675 for the ball pivot, per helicopter. Based on these figures, we estimate the total cost impact of the AD on U.S. operators to be \$32,765, assuming 15 helicopters require a control rod and ball pivot to be replaced.

Comments Invited

This AD is a final rule that involves requirements that affect flight safety and was not preceded by notice and an opportunity for public comment; however, we invite you to submit any written data, views, or arguments regarding this AD. Send your comments to an address listed under **ADDRESSES**. Include “Docket No. FAA–2008–0101; Directorate Identifier 2007–SW–76–AD” at the beginning of your comments. We specifically invite comments on the overall regulatory, economic, environmental, and energy aspects of the AD. We will consider all comments received by the closing date and may amend the AD in light of those comments.

We will post all comments we receive, without change, to <http://www.regulations.gov>, including any personal information you provide. We will also post a report summarizing each substantive verbal contact with FAA personnel concerning this AD. Using the search function of our docket web site, you can find and read the comments to any of our dockets, including the name of the individual who sent the comment. You may review the DOT’s complete Privacy Act Statement in the **Federal Register** published on April 11, 2000 (65 FR 19477–78), or you may visit <http://www.regulations.gov> for the Federal government privacy notice.

Regulatory Findings

We have determined that this AD will not have federalism implications under Executive Order 13132. This AD will not have a substantial direct effect on the States, on the relationship between the national Government and the States, or on the distribution of power and

responsibilities among the various levels of government.

For the reasons discussed above, I certify that the regulation:

1. Is not a "significant regulatory action" under Executive Order 12866;
2. Is not a "significant rule" under the DOT Regulatory Policies and Procedures (44 FR 11034, February 26, 1979); and
3. Will not have a significant economic impact, positive or negative, on a substantial number of small entities under the criteria of the Regulatory Flexibility Act.

We prepared an economic evaluation of the estimated costs to comply with this AD. See the AD docket to examine the economic evaluation.

Authority for This Rulemaking

Title 49 of the United States Code specifies the FAA's authority to issue rules on aviation safety. Subtitle I, section 106, describes the authority of the FAA Administrator. Subtitle VII, Aviation Programs, describes in more detail the scope of the Agency's authority.

We are issuing this rulemaking under the authority described in subtitle VII, part A, subpart III, section 44701, "General requirements." Under that section, Congress charges the FAA with promoting safe flight of civil aircraft in air commerce by prescribing regulations

for practices, methods, and procedures the Administrator finds necessary for safety in air commerce. This regulation is within the scope of that authority because it addresses an unsafe condition that is likely to exist or develop on products identified in this rulemaking action.

List of Subjects in 14 CFR Part 39

Air transportation, Aircraft, Aviation safety, Safety.

Adoption of the Amendment

■ Accordingly, pursuant to the authority delegated to me by the Administrator, the Federal Aviation Administration amends part 39 of the Federal Aviation Regulations (14 CFR part 39) as follows:

PART 39—AIRWORTHINESS DIRECTIVES

- 1. The authority citation for part 39 continues to read as follows:

Authority: 49 U.S.C. 106(g), 40113, 44701.

§ 39.13 [Amended]

- 2. Section 39.13 is amended by adding a new airworthiness directive to read as follows:

2007-26-51 Eurocopter Deutschland

GmbH: Amendment 39-15357. Docket No. FAA-2008-0101; Directorate Identifier 2007-SW-76-AD.

Applicability

Model EC135 helicopters, serial number (S/N) 0005 up to and including S/N 0444, except S/N 0028, and with tail rotor control rod (control rod), part number L672M2005207, installed, certificated in any category.

Compliance

Required as indicated, unless accomplished previously.

To prevent the failure of a control rod and subsequent loss of control of the helicopter, do the following:

(a) Within 5 hours time-in-service (TIS), inspect the control rod, shown in item 7, Figure 1, of this AD, with the parts identified in parenthesis as follows:

(1) Pull the control rod (7) until it reaches its stop position. Inspect attachment hardware of control rod (7) for a tight fit. Manually inspect for possible relative motion between control rod (7) and yaw actuator (8).

(2) Inspect the locking plate (9) for a tight fit.

(3) Visually inspect the attachment hardware between control rod (7) and yaw actuator (8) for play or thread exposure. If play or thread exposure is found, before further flight, replace the control rod with an airworthy control rod.

(b) Inspect the ball pivot as shown in item 11, Figure 1, of this AD by removing the tail rotor drive shaft fairing and inspecting for a loose bearing or play. If a loose bearing or play is found, before further flight, replace the ball pivot with an airworthy ball pivot.

BILLING CODE 4910-13-P

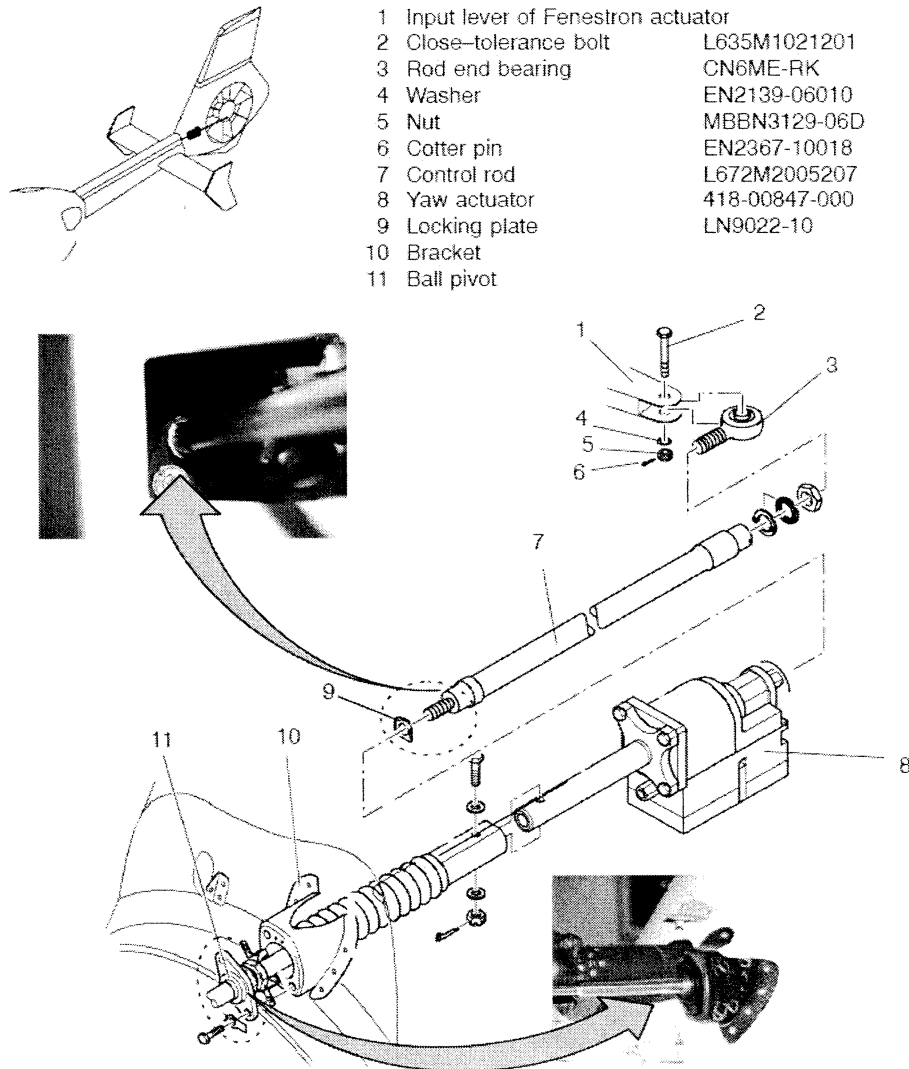

Ball Pivot and Control Rod
Figure 1

BILLING CODE 4910-13-C

Note 1: Eurocopter Alert Service Bulletin No. EC135-67A-017, dated December 13, 2007, pertains to the subject of this AD.

(c) To request a different method of compliance or a different compliance time for this AD, follow the procedures in 14 CFR 39.19. Contact the Manager, Safety Management Group, FAA, ATTN: Chinh Vuong, Rotorcraft Directorate, Fort Worth, Texas 76193-0111, telephone (817) 222-5116, fax (817) 222-5961, for information about previously approved alternative methods of compliance.

Note 2: The subject of this AD is addressed in European Aviation Safety Agency (EASA) AD No. 2007-0301-E, dated December 13, 2007.

(d) This amendment becomes effective on February 19, 2008, to all persons except those persons to whom it was made immediately effective by Emergency AD No. 2007-26-51,

issued December 14, 2007, which contained the requirements of this amendment.

Issued in Fort Worth, Texas, on January 23, 2008.

Scott A. Horn,

*Acting Manager, Rotorcraft Directorate,
Aircraft Certification Service.*

[FR Doc. E8-1702 Filed 1-31-08; 8:45 am]

BILLING CODE 4910-13-P

**SECURITIES AND EXCHANGE
COMMISSION**

**17 CFR Parts 202, 230, 240, 260, and
270**

**[Release Nos. 33-8885, 34-57218, 39-2452,
IC-28137]**

**Amendment of Procedures for
Payment of Fees**

AGENCY: Securities and Exchange
Commission.

ACTION: Final rule.

SUMMARY: The Securities and Exchange Commission is amending its procedures for payment of fees imposed under the federal securities laws to update the procedures and reflect the designation of U.S. Bank, N.A. ("U.S. Bank") as the